

DIMENSIONS **

SPAN X RISE	T (INCHES)	A (FT.-IN.)	B (FT.-IN.)	C (INCHES)	E (FT.-IN.)	F (FT.-IN.)	G (FT.-IN.)	H (FT.-IN.)	SLOPE (X:Y)
2' X 2'	4	2-8	2-8	4	3-0	3-0	1-0	1-0	3:1
3' X 2'	4	3-8	2-8	4	3-0	3-0	1-0	1-0	3:1
3' X 3'	4	3-8	3-8	4	2-0	4-0	1-8	1-4	3:1
4' X 2'	5	4-10	2-10	5	3-0	3-0	1-0	1-0	3:1
4' X 3'	5	4-10	3-10	5	2-0	4-0	1-8	1-4	3:1
4' X 4'	5	4-10	4-10	5	2-0	4-0	2-0	2-0	2:1
5' X 2'	6	6-0	3-0	6	3-0	3-0	1-0	1-0	3:1
5' X 3'	6	6-0	4-0	6	2-0	4-0	1-8	1-4	3:1
5' X 4'	6	6-0	5-0	6	2-0	4-0	2-0	2-0	2:1
5' X 5'	6	6-0	6-0	6					
6' X 2'	7	7-2	3-2	7	3-0	3-0	1-0	1-0	3:1
6' X 3'	7	7-2	4-2	7	2-0	4-0	1-8	1-4	3:1
6' X 4'	7	7-2	5-2	7	2-0	4-0	2-0	2-0	2:1
6' X 5'	7	7-2	6-2	7	2-0	4-0	3-0	2-0	2:1
6' X 6'	7	7-2	7-2	7	2-0	4-0	4-0	2-0	2:1
7' X 4'	8	8-4	5-4	8	2-0	4-0	2-0	2-0	2:1
7' X 5'	8	8-4	6-4	8					
7' X 6'	8	8-4	7-4	8					
7' X 7'	8	8-4	8-4	8					
8' X 4'	8	9-4	4-4	8	2-0	4-0	2-0	2-0	2:1
8' X 4'	8	9-4	5-4	8					
8' X 5'	8	9-4	6-4	8					
8' X 6'	8	9-4	7-4	8					
8' X 7'	8	9-4	8-4	8					
8' X 8'	8	9-4	9-4	8					
9' X 5'	9	10-6	6-6	9					
9' X 6'	9	10-6	7-6	9					
9' X 7'	9	10-6	8-6	9					
9' X 8'	9	10-6	9-6	9					
9' X 9'	9	10-6	10-6	9					
10' X 5'	10	11-8	6-8	10					
10' X 6'	10	11-8	7-8	10					
10' X 7'	10	11-8	8-8	10					
10' X 8'	10	11-8	9-8	10					
10' X 9'	10	11-8	10-8	10					
10' X 10'	10	11-8	11-8	10					
11' X 4'	11	12-10	5-10	11					
11' X 6'	11	12-10	7-10	11					
11' X 8'	11	12-10	9-10	11					
11' X 10'	11	12-10	11-10	11					
11' X 11'	11	12-10	12-10	11					
12' X 4'	12	14-0	6-0	12					
12' X 6'	12	14-0	8-0	12					
12' X 8'	12	14-0	10-0	12					
12' X 10'	12	14-0	12-0	12					
12' X 12'	12	14-0	14-0	12					

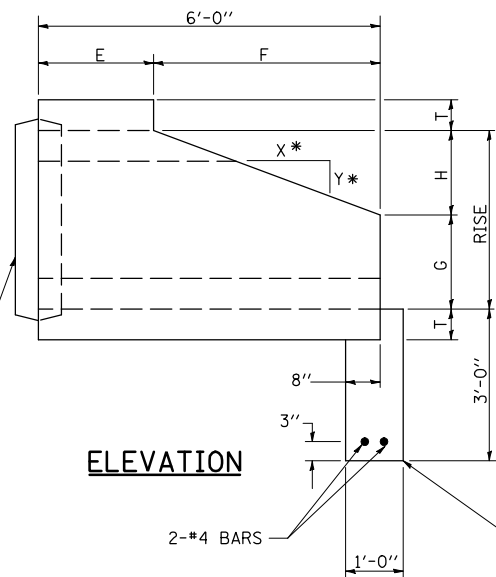

* 2:1 SLOPE MINIMUM

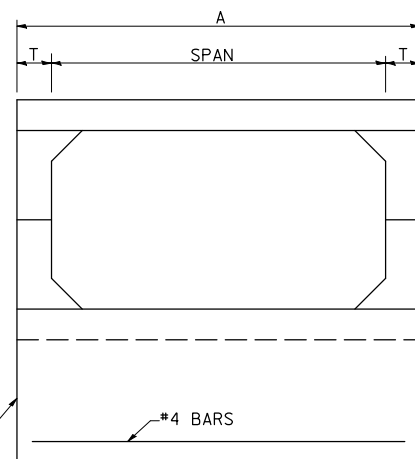

END VIEW

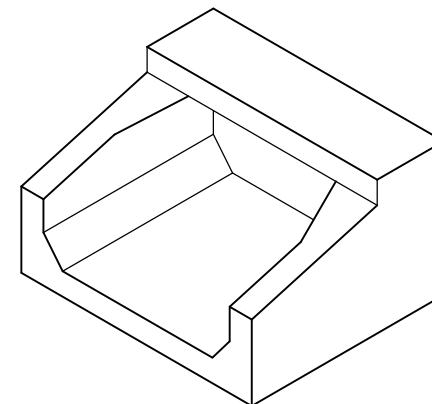

ISOMETRIC

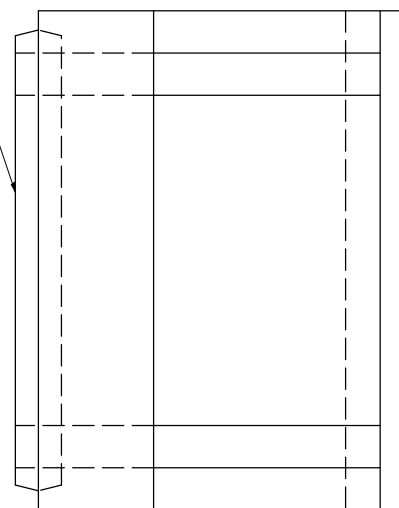

PLAN

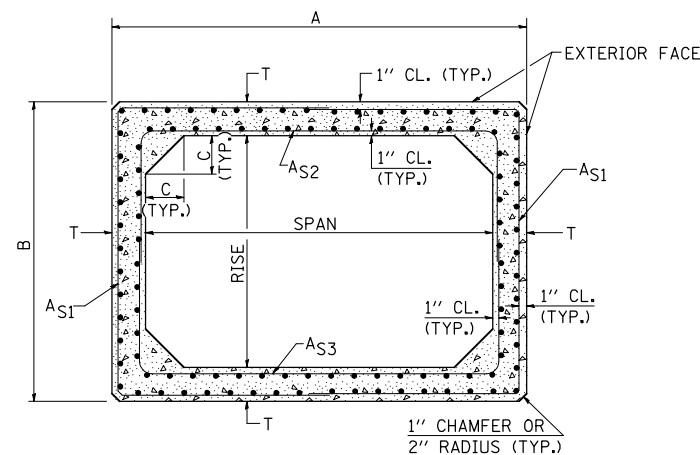

CROSS SECTION

GENERAL NOTES

SHOP DRAWINGS SHALL BE SUBMITTED IN ACCORDANCE WITH THE REQUIREMENTS OF ARTICLE 1042.03(b) OF THE STANDARD SPECIFICATIONS.

MINIMUM CONCRETE STRENGTH SHALL BE 5000 PSI AFTER 28 DAYS.

THE JOINTS OF THE PRECAST BOX SECTIONS SHALL BE SEALED WITH MASTIC IN ACCORDANCE WITH SECTION 1055 OF THE STANDARD SPECIFICATIONS FOR ROAD AND BRIDGE CONSTRUCTION.

THE TERMS AS1, AS2, & AS3 DENOTE THE REQUIRED STEEL AREAS FOR REINFORCEMENT AS SPECIFIED IN AASHTO M273. REINFORCEMENT SHALL BE WELDED WIRE FABRIC CONFORMING TO AASHTO M55-81.

**** NOTE:**

THE DIMENSIONS INDICATED ARE FOR END SECTIONS THAT ARE TO BE USED WITH PRECAST BOX CULVERT SECTIONS DESIGNED FOR 2' OR MORE OF FILL. THE DIMENSIONS MUST BE MODIFIED FOR THE END SECTION TO BE COMPATIBLE WITH PRECAST CULVERT SECTIONS DESIGNED FOR LESS THAN 2' OF FILL.

Note: All dimensions are in INCHES (millimeters) unless otherwise shown.

STD. 9-50 (FROM DISTRICT 9)

FILE NAME =	USER NAME = bucklesjj	DESIGNED -	REVISED -
ct:\pw\work\p\wdot\bucklesjj\d0170848\0570507-shd-details.dgn		DRAWN -	REVISED -
PLOT SCALE = 40.0000' / IN.		CHECKED -	REVISED -
PLOT DATE = 12/9/2009		DATE -	REVISED -

**STATE OF ILLINOIS
DEPARTMENT OF TRANSPORTATION**

**BOX CULVERT END SECTION
(PRECAST OPTION)**

SCALE: SHEET NO. OF SHEETS STA. TO STA.

DISTRICT 5 DETAIL NO. 54001AAA

F.A.P. RTE.	SECTION	COUNTY	TOTAL SHEETS	SHEET NO.
315	*	McLean	115	69
*101,102X,RS-2 & 55RS-PRK LN CONTRACT NO. 70507				
ILLINOIS FED. AID PROJECT				