

PERMANENT SURVEY MARKERS

STATION	DESCRIPTION
827+48.98	POT
832+70.40	PC
855+97.26	PT
857+91.47	POT

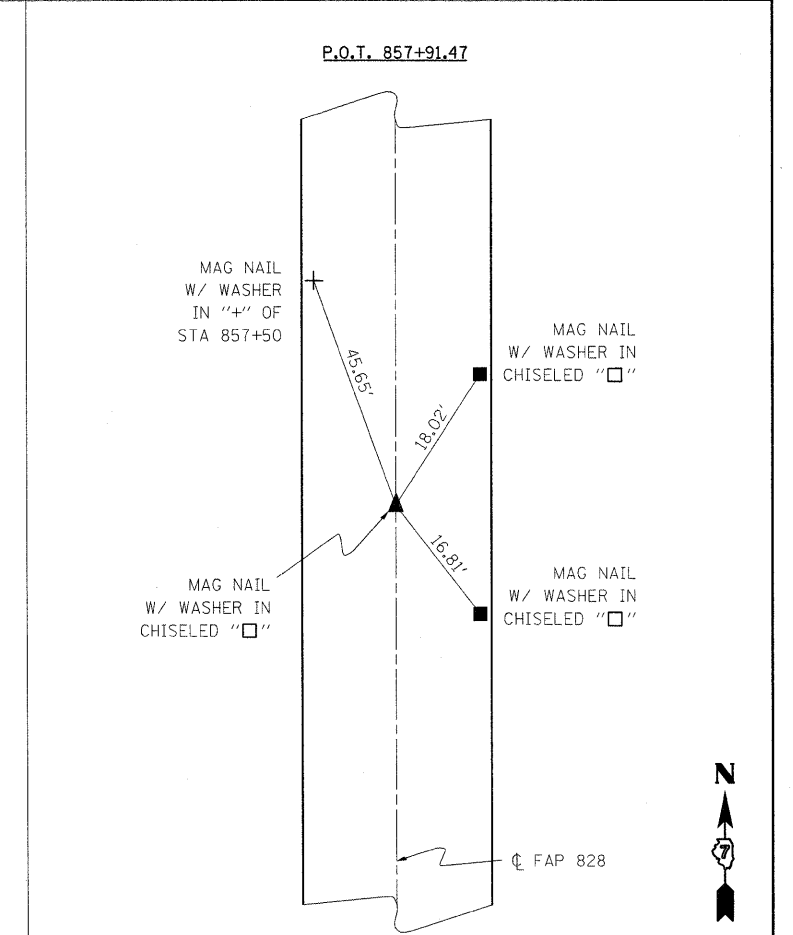
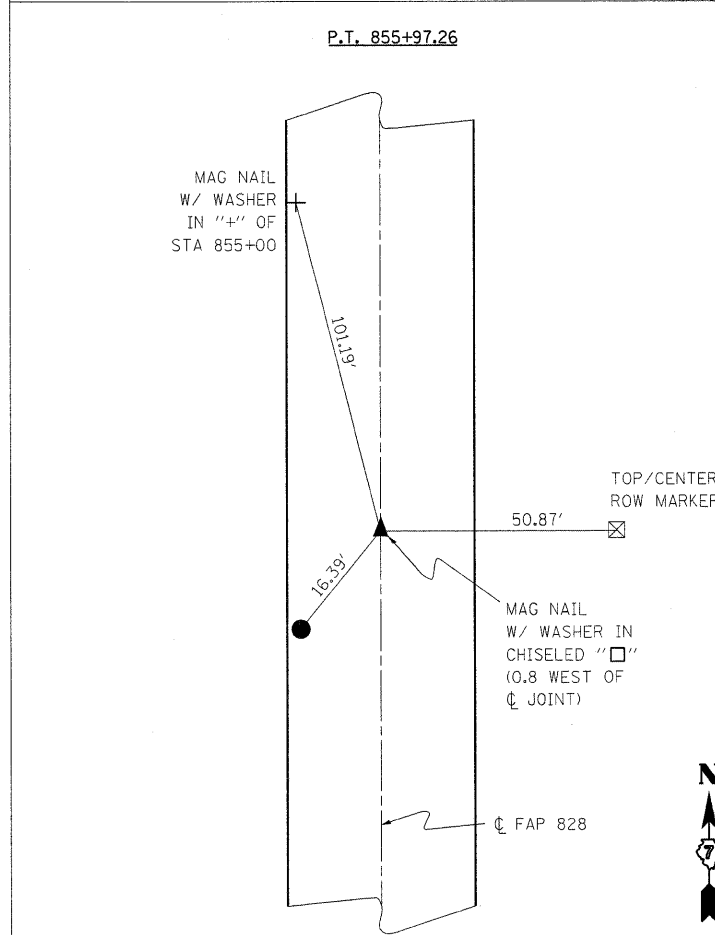
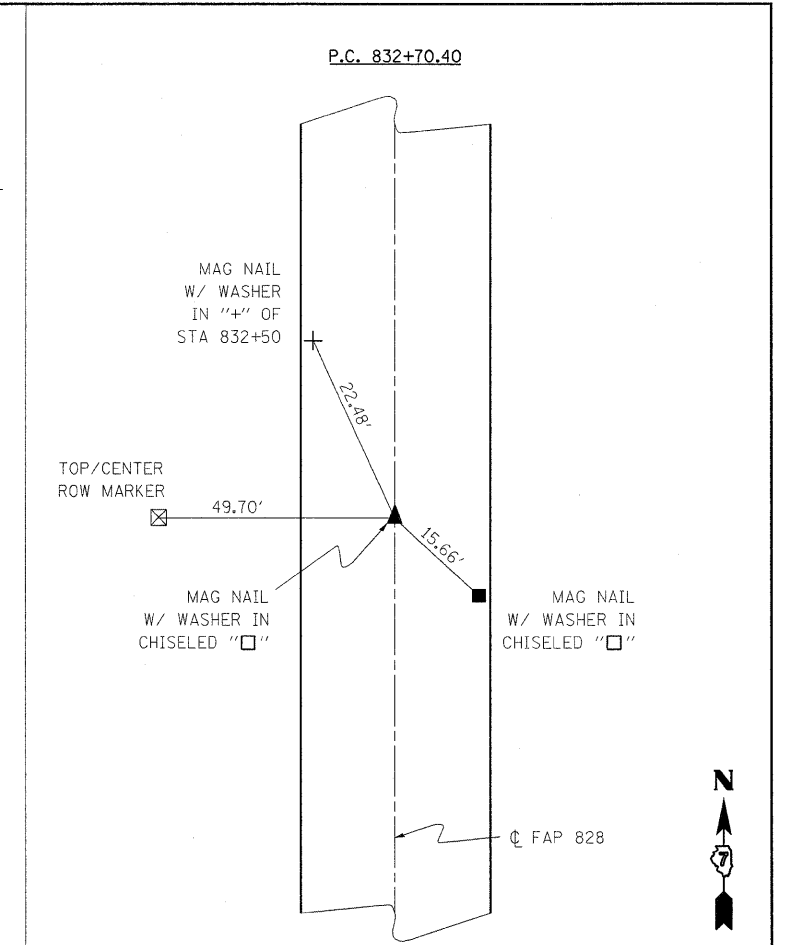
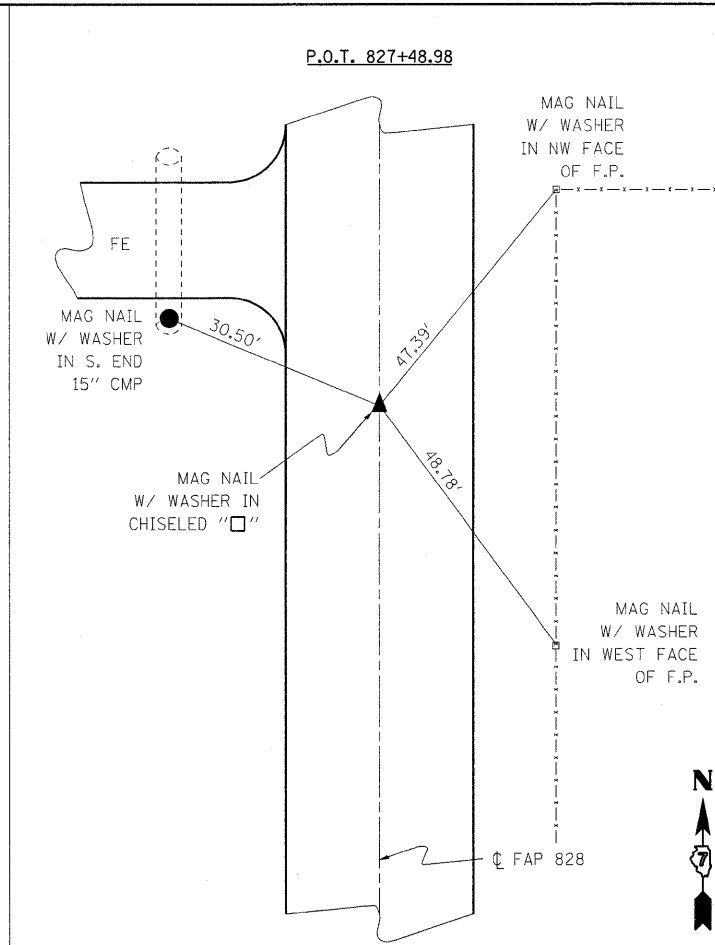

FILE NAME =	USER NAME = teasleyck	DESIGNED -	REVISED -
ca\pwwork\pwidot\TEASLEYCK\d8123166\07	4371-sht-tles.dgn	DRAWN -	REVISED -
	PLOT SCALE = 50.0000' / IN.	CHECKED -	REVISED -
	PLOT DATE = 12/2/2009	DATE -	REVISED -

STATE OF ILLINOIS
DEPARTMENT OF TRANSPORTATION

SURVEY TIES

SCALE:	SHEET NO. OF SHEETS	STA. TO STA.
--------	---------------------	--------------

F.A.P. RTE. 828	SECTION (106.107)RS-2	COUNTY Clay	TOTAL SHEETS 9	SHEET NO. 5
CONTRACT NO. 74371				

ILLINOIS FED. AID PROJECT