

SECTION B-B

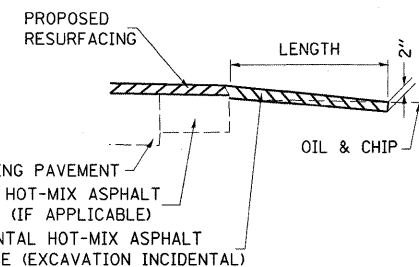

SECTION C-C

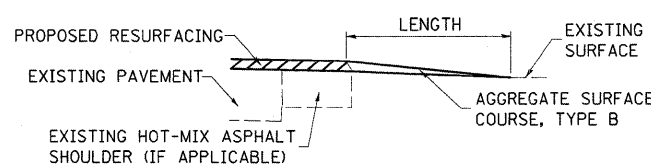
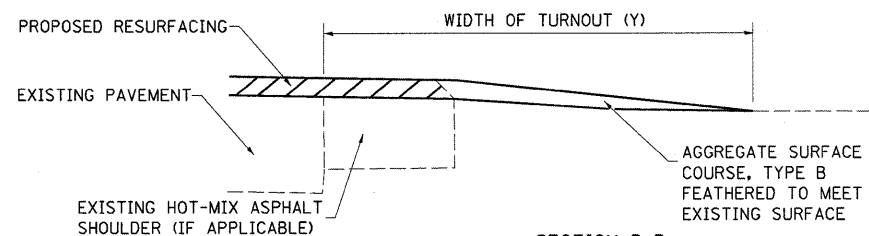
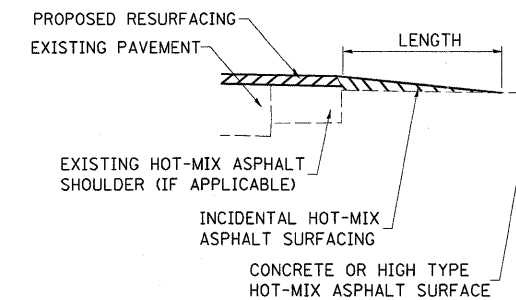

SECTION D-D

TYPICAL SECTION AT MAILBOX TURNOUT

NOTE: SEE STANDARD 406201 FOR MAILBOX TURNOUT DETAILS

NOTES

THE COST OF THE ASPHALT MATERIALS, AND AGGREGATE (PRIME COAT) FOR ENTRANCES AND PUBLIC ROADS AND APPROACHES SHALL BE INCLUDED IN THE PAY ITEM INCIDENTAL HOT-MIX ASPHALT SURFACING.

THE COST OF EXCAVATION IS INCLUDED IN THE PAY ITEM INCIDENTAL HOT-MIX ASPHALT SURFACING.

IF THERE IS NOT EXISTING HOT-MIX ASPHALT SHOULDER THEN THE ENTRANCE TAPER STARTS AT THE EDGE OF EXISTING PAVEMENT.

THE COST OF THE BITUMINOUS MATERIALS AND AGGREGATE (PRIME COAT) FOR ENTRANCES AND PUBLIC ROAD APPROACHES SHALL BE INCLUDED IN THE PAY ITEM INCIDENTAL HOT-MIX ASPHALT SURFACING.

SIDE	STATION	TYPE	INCIDENTAL HOT-MIX ASPHALT SURFACING		AGGREGATE SURFACE COURSE, TYPE B
			TON	TON	
LT	17+27	PRA	3.58		
RT	17+27	PRA	2.88		
LT	14+21	PRA	4.89		
RT	14+21	PRA	3.43		
LT	10+61	PRA	4.17		
RT	10+61	PRA	4.14		
LT	06+94	PRA	4.52		
RT	06+94	PRA	4.31		
LT	04+29	PRA	3.71		
LT	02+49	PRA	3.52		
RT	02+49	PRA	3.83		
LT	0+31	PRA	11.80		
RT	0+31	PRA	11.69		
RT	32+00	FE	0.45	0.3	
LT	37+40	PE	1.15	1.1	
LT	39+53	PRA	2.81		
LT	41+64	PRA	3.09		
RT	45+65	FE	0.45	0.6	
RT	46+04	FE	0.36	0.5	
LT	48+79	FE	0.33	0.7	
LT	54+04	CE	3.13		
LT	54+91	FE	0.30	0.6	
LT	58+40	FE	0.39	0.7	
RT	61+37	PRA	6.14		
LT	63+19	PE	0.92		
LT	64+80	PRA	6.07		
RT	76+10	FE	0.85	1.1	
RT	88+62	FE	0.44	0.6	
LT	89+71	PE/MBT	1.58		
LT	95+48	PE/MBT	1.89		
LT	97+64	PE/MBT	1.82		
LT	98+70	PE	1.21		
RT	98+70	FE	0.88	0.9	
LT	101+97	PE/MBT	1.61		
RT	105+13	PE/MBT	1.42		
RT	105+87	PE/MBT	1.80		
RT	108+56	PE	1.69		
LT	118+04	PE	1.75		
RT	132+65	PE	1.98		
LT	149+34	FE		0.8	
RT	150+16	FE	1.17	1.5	
LT	165+44	FE	0.35	0.7	
RT	165+50	FE	0.35	0.7	
LT	181+45	PRA	2.96		
RT	181+80	PRA	1.65		
RT	197+08	FE	0.24	0.4	
LT	197+08	FE	0.26	0.4	
RT	226+20	FE	0.31	0.6	
LT	229+81	FE	0.36	0.5	
LT	244+31	PRA	2.87		
RT	244+70	PRA	1.68		
LT	259+85	FE	0.36	0.6	
RT	260+01	FE	0.32	0.6	
RT	271+47	PRA	2.92		
LT	272+54	PRA	3.10		
LT	290+08	PRA	0.97		
RT	290+12	FE	0.32	0.8	
LT	305+39	PRA	9.02		
LT	316+42	FE	0.23	0.5	
RT	316+42	FE	0.29	0.4	
RT	322+25	PE	1.27		
LT	322+31	MBT	0.66		
RT	329+87	FE	0.28	0.5	
LT	330+04	FE	0.29	0.5	
LT	332+82	PRA/MBT	1.43		
RT	332+85	FE	0.28	0.6	
LT	340+40	MBT	1.04		
RT	341+20	PE	1.02		
RT	343+07	PRA	1.93		
LT	343+18	PRA	2.27		
LT	347+91	FE	0.23	0.5	
RT	348+01	PE	2.49		
RT	350+94	FE	0.21	0.6	
LT	356+74	FE	0.35	0.6	
RT	356+74	FE	0.29	0.6	
LT	04+22	FE	0.35	0.5	
RT	05+88	PE	1.88		
LT	14+36	FE	0.52	0.8	
RT	37+20	FE	0.37	0.5	
TOTALS			158	21	

FE=FIELD ENTRANCE PRA - PUBLIC ROAD APPROACH
PE=PRIVATE ENTRANCE MBT - MAILBOX TURNOUT
CE=COMMERCIAL ENTRANCE

FILE NAME =

USER NAME = teasleyck

DESIGNED - 08-03-99

REVISED - 03-13-07

DESIGNED BY -

DRAWN -

CHECKED -

REVISED -

PLOT SCALE = 50.0000' / 1"

DATE -

REVISED -

REVISED -

STATE OF ILLINOIS
DEPARTMENT OF TRANSPORTATION

RURAL ENTRANCE SCHEDULE AND MAILBOX TURNOUT DETAILS
WITH SHOULDERS

SCALE: SHEET NO. OF SHEETS STA. TO STA.

F.A.P. RTE.	SECTION	COUNTY	TOTAL SHEETS	SHEET NO.
758	3RS-5, (4,5)RS-2	Moultrie	25	10
CONTRACT NO. 74406				