

11/10/2008 4:33:55 PM

pt:\001\les\000024\cf\luciver-bridge-plans\0600332steel\ca\ls.dgn

ROUTE NO.	SECTION	COUNTY	TOTAL SHEETS	SHEET NO.
	*	MADISON	93	44
SHEET NO. 22				
47 SHEETS				

\* 60-15HB-3 Contract No. 76706

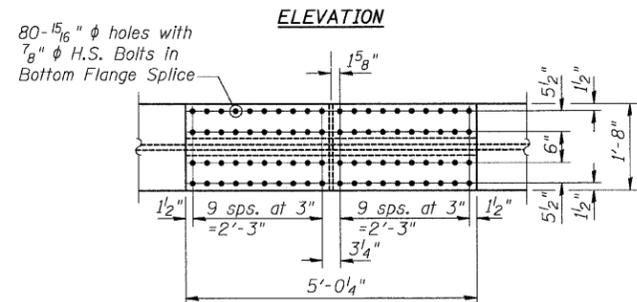
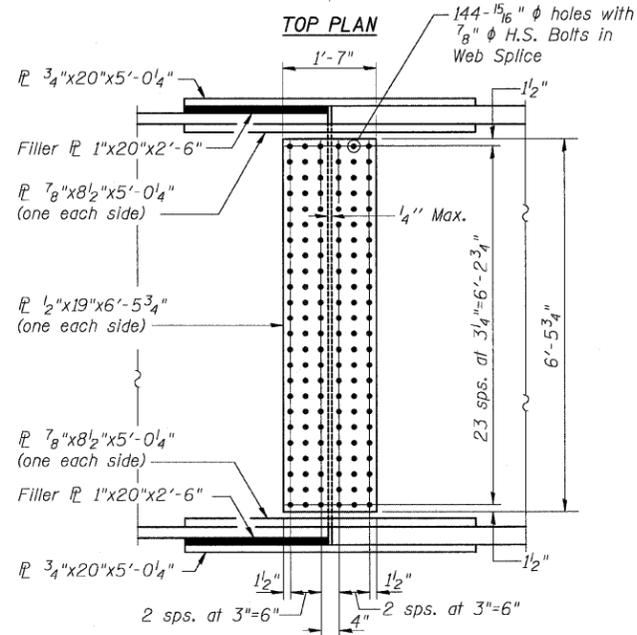
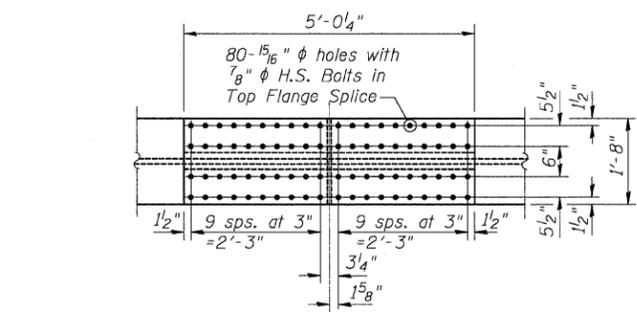

**SPLICE #1**  
(FOR GIRDERS 7, 8, 9 & 10)

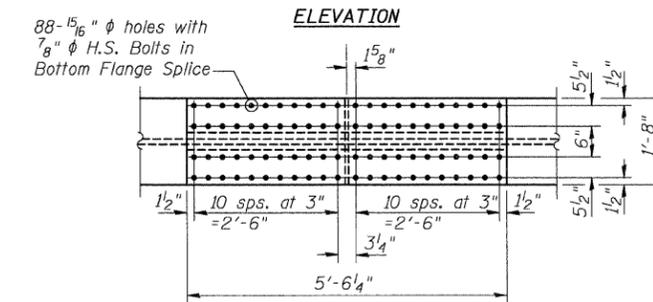
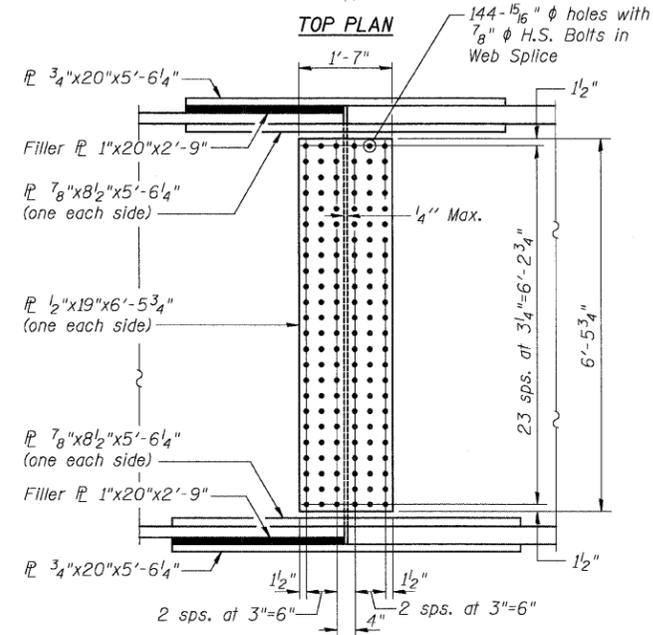
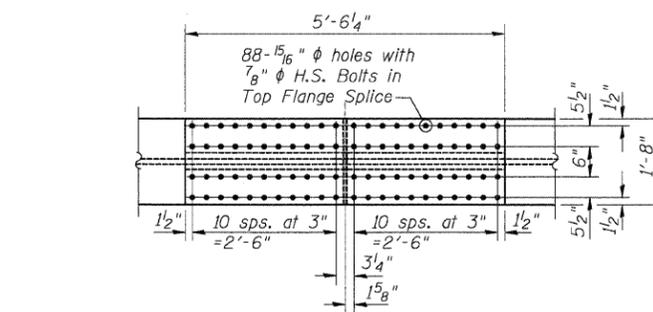

**SPLICE #1**  
(FOR GIRDERS 11 & 12)

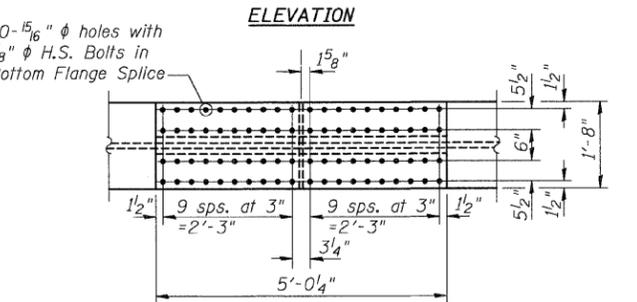
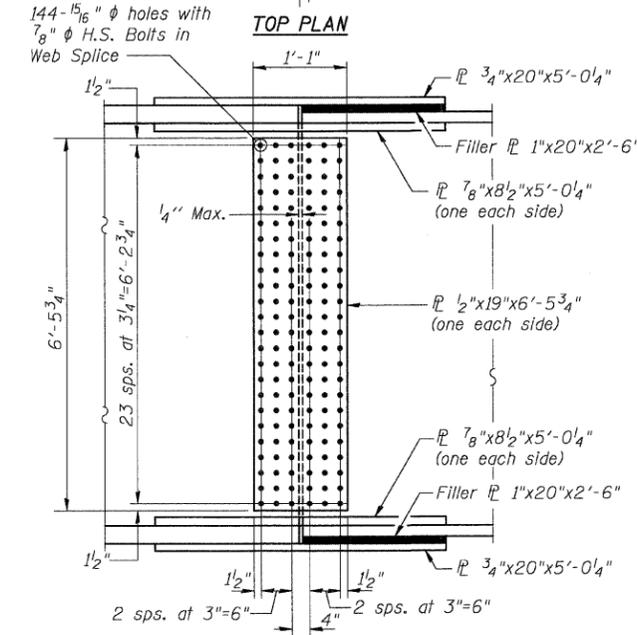
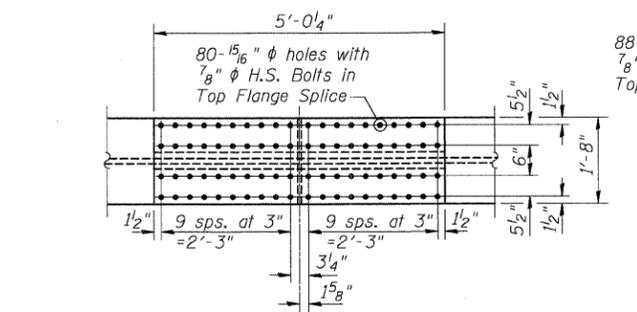

**SPLICE #2**  
(FOR GIRDERS 7, 8, 9 & 10)

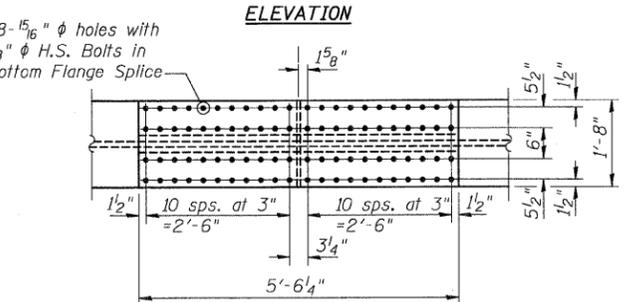
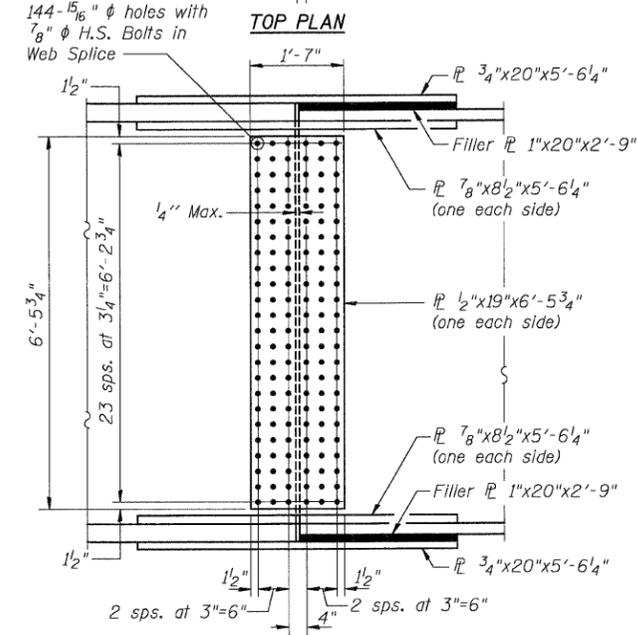
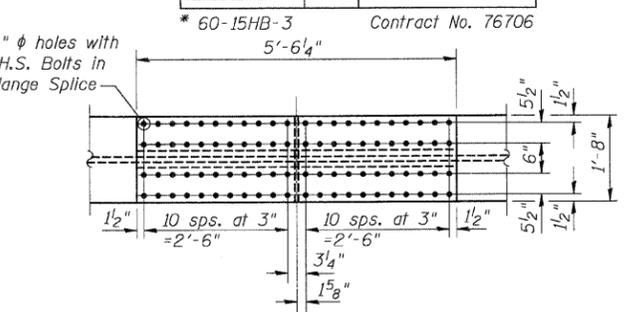

**SPLICE #2**  
(FOR GIRDERS 11 & 12)

Notes:  
All splice plates shall be AASHTO M270 Grade 50 steel, except for filler plates.  
All splice plates shall conform to Notch Toughness Requirements (N.T.R.), except for filler plates.

**SPLICE DETAILS**  
RAMP B OVER FAP RTE 310  
SECTION 60-15HB-3  
MADISON COUNTY  
STATION 17+72.64 (RAMP B)  
SN 060-0332

DESIGNED	ADL
CHECKED	WLW
DRAWN	BGJ
CHECKED	WLW