

STA. 108+40 & STA. 108+65 REMOVAL DETAIL
PLAN VIEW

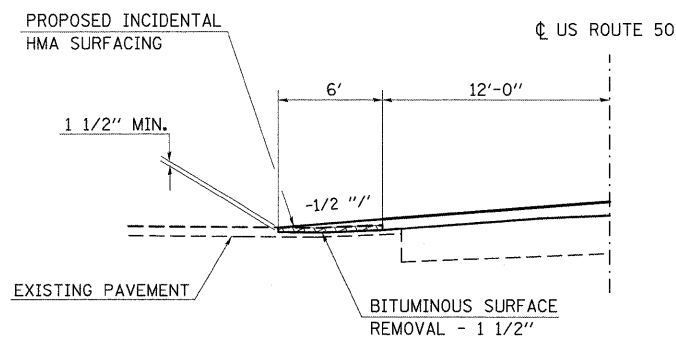

SECTION DETAIL G-G
CL STA. 108+40

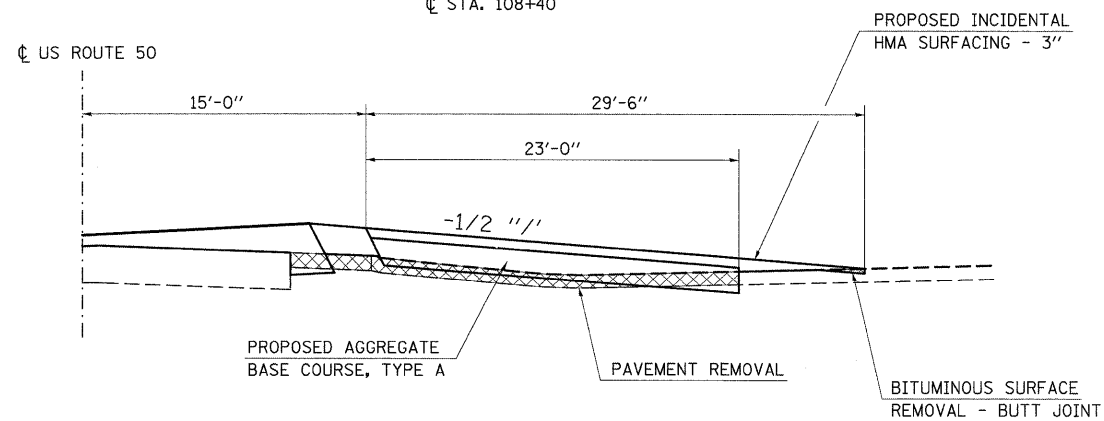

SECTION DETAIL H-H
CL STA. 108+65

FILE NAME =	USER NAME = harbaugh-rd	DESIGNED -	REVISED -
c:\pwork\pwork\DOT\HARBAUGH\RD\dms52298\plan03087.dgn		DRAWN -	REVISED -
		CHECKED -	REVISED -
		DATE -	REVISED -

STATE OF ILLINOIS
DEPARTMENT OF TRANSPORTATION

ENTRANCE DETAILS

SCALE:	SHEET NO. 3 OF 3 SHEETS	STA.	TO STA.
--------	-------------------------	------	---------

F.A.P. RTE.	SECTION	COUNTY	TOTAL SHEETS	SHEET NO.
327	15B-1	MARION	58	49
CONTRACT NO. 76A59				
ILLINOIS FED. AID PROJECT				