

## TYPICAL SECTIONS-LOCATION 2

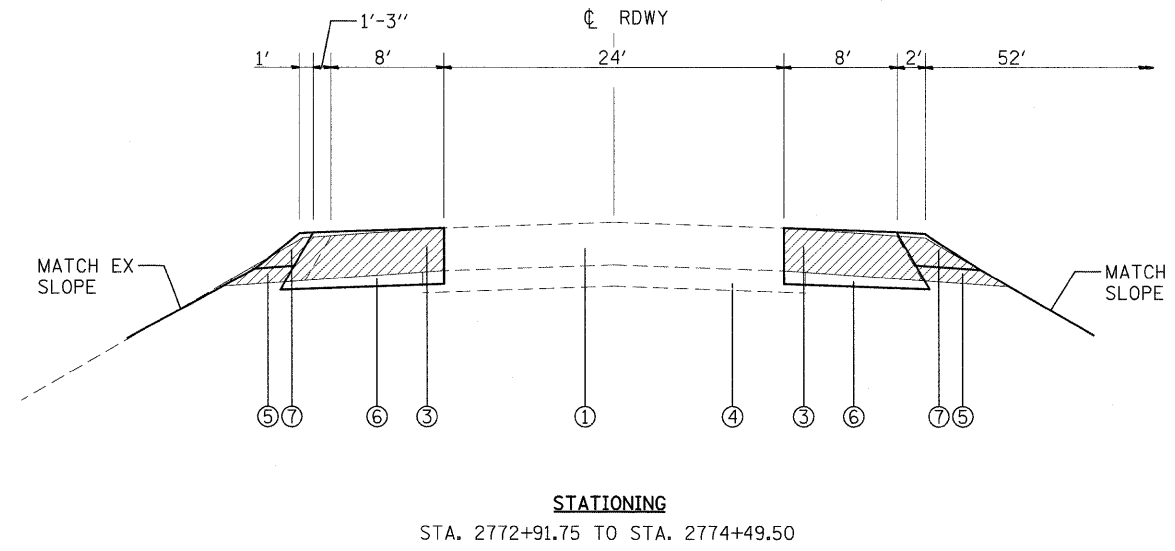
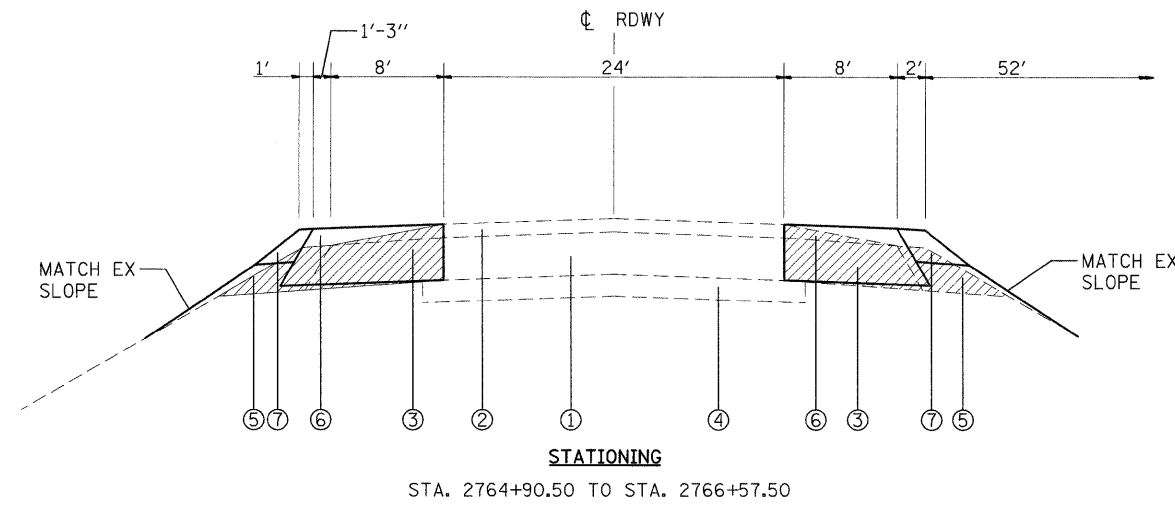

### LEGEND

- ① EXISTING CONTINUOUSLY REINFORCED P.C.C. PAVEMENT - 8"
- ② EXISTING HMA RESURFACING - 3"
- ③ EXISTING HMA SHOULDER - 8"
- ④ EXISTING STABILIZED SUB-BASE - 4"
- ⑤ EXISTING AGGREGATE SHOULDER
- ⑥ PROPOSED HMA BASE COURSE WIDENING - 10 1/2"
- ⑦ PROPOSED AGGREGATE SHOULDER, TYPE B - 6"

FILE NAME =	USER NAME = manntm	DESIGNED -	REVISED -	<b>STATE OF ILLINOIS DEPARTMENT OF TRANSPORTATION</b>	<b>TYPICAL SECTION LOCATION 2</b>	F.A.P. RTE.	SECTION	COUNTY	TOTAL SHEETS	SHEET NO.	
cc:\pwork\pwidot\manntm\dms32470\p1n10207b.dgn	PLOT SCALE = 50.0000' / IN.	DRAWN -	REVISED -			327	14-12BR-1	CLINTON	72	6	
PLOT DATE = 12/8/2009	DATE -	CHECKED -	REVISED -			<b>CONTRACT NO. 76B27</b>					
		DATE -	REVISED -			SCALE:	SHEET NO. OF SHEETS	STA. TO STA.	FED. ROAD DIST. NO. 8 ILLINOIS FED. AID PROJECT		