

FLOOR DRAIN PLAN
(North end of bridge shown -
South end similar)

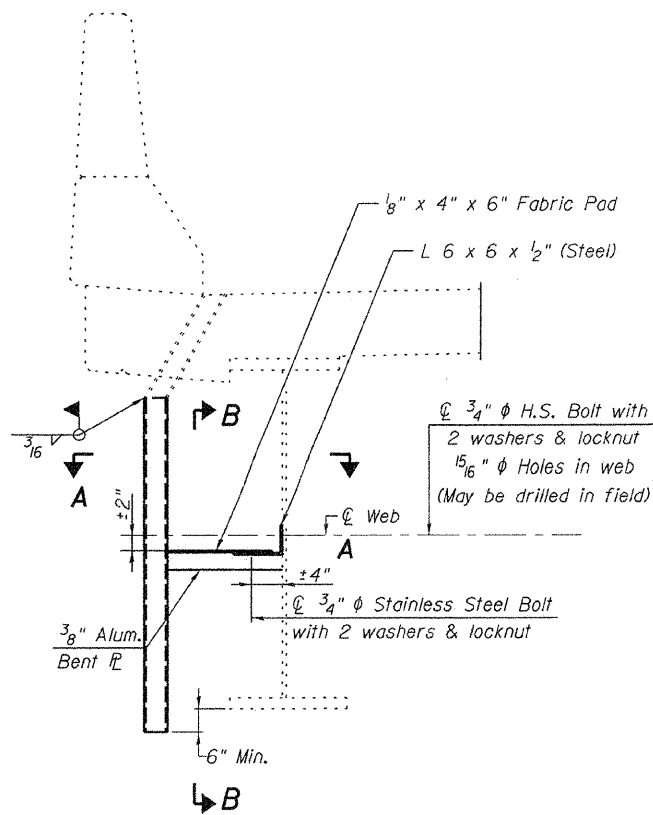

DRAIN EXTENSION DETAIL
(4 Required)

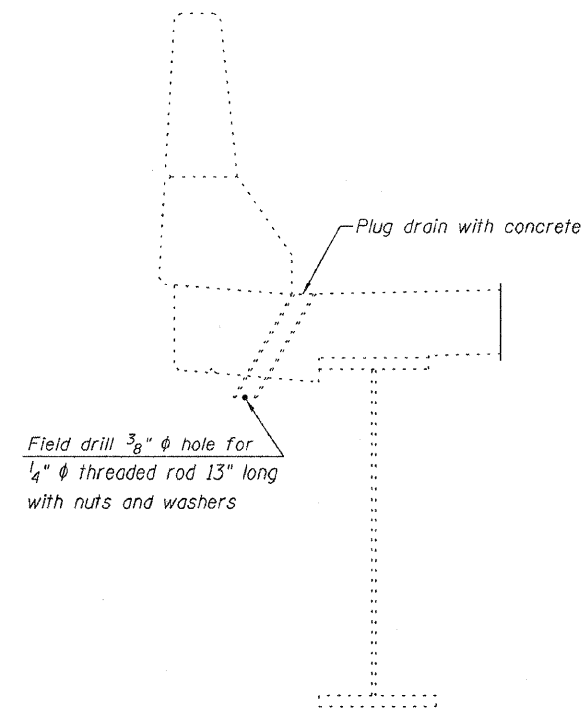

DRAIN ELIMINATION DETAIL
(4 Required)

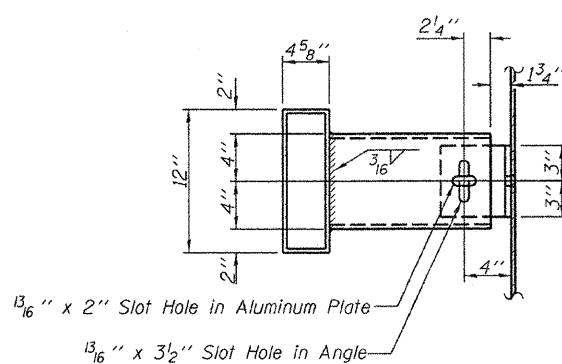

SECTION A-A

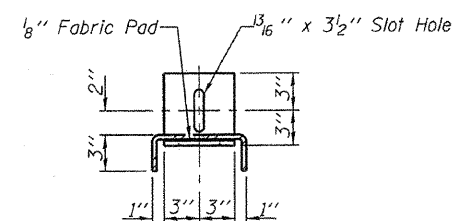

SECTION B-B

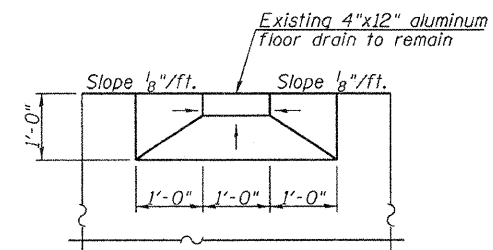

DRAIN DETAIL

BILL OF MATERIAL

ITEM	UNIT	TOTAL
Floor Drain Extension	Each	4
Plug Existing Deck Drains	Each	4

FLOOR DRAIN DETAILS
IL. ROUTE 160 OVER U.S. ROUTE 50
S.N. 014-0065



Allen Henderson & Associates, Inc.
Civil and Structural Engineers Springfield, IL.
62703 Phone: (217)544-8033 IL. Design Firm
No. 184-001907

SHEET NO. 9
14 SHEETS

F.A.P. RTE.	SECTION	COUNTY	TOTAL SHEETS	SHEET NO.
690	14-12BR-1	CLINTON	72	29
FED. ROAD DIST. NO. -		ILLINOIS	FED. AID PROJECT	
CONTRACT NO. 76B27				