

**VIEW A-A  
ROUND HEAD BOLT**

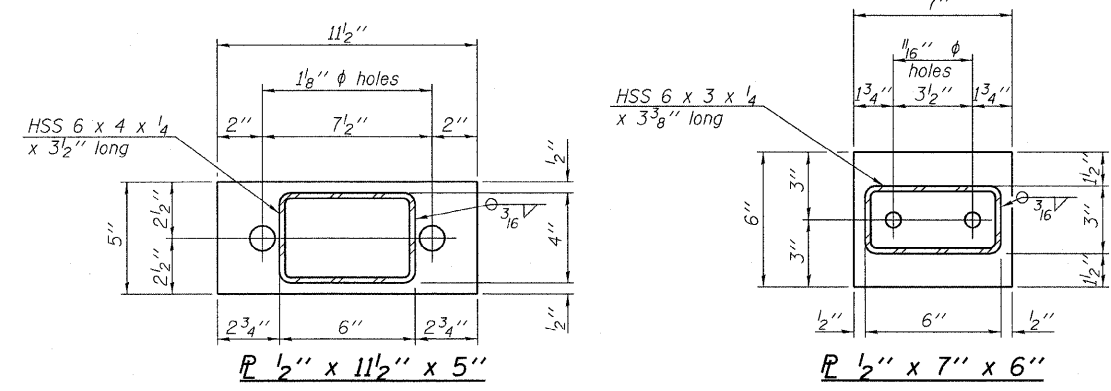

Note: Cost of curled end sections shall be included with the Steel Railing. (4 Required)

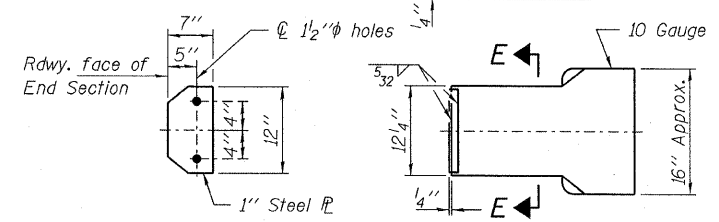

**SECTION E-E CURLED END SECTION DETAILS**

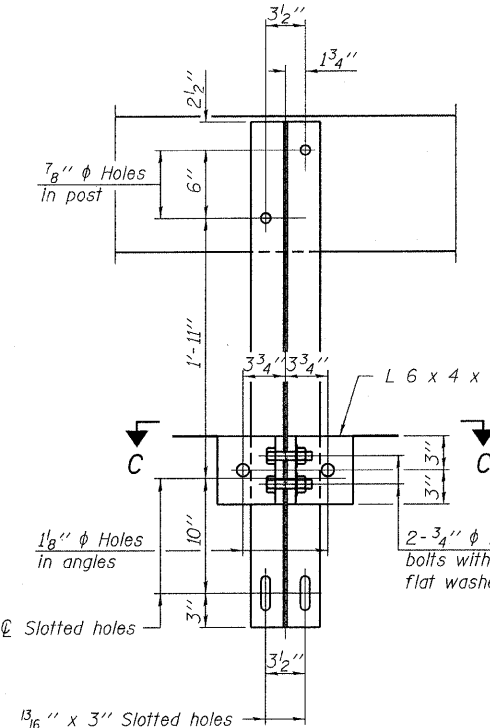

**SECTION B-B**

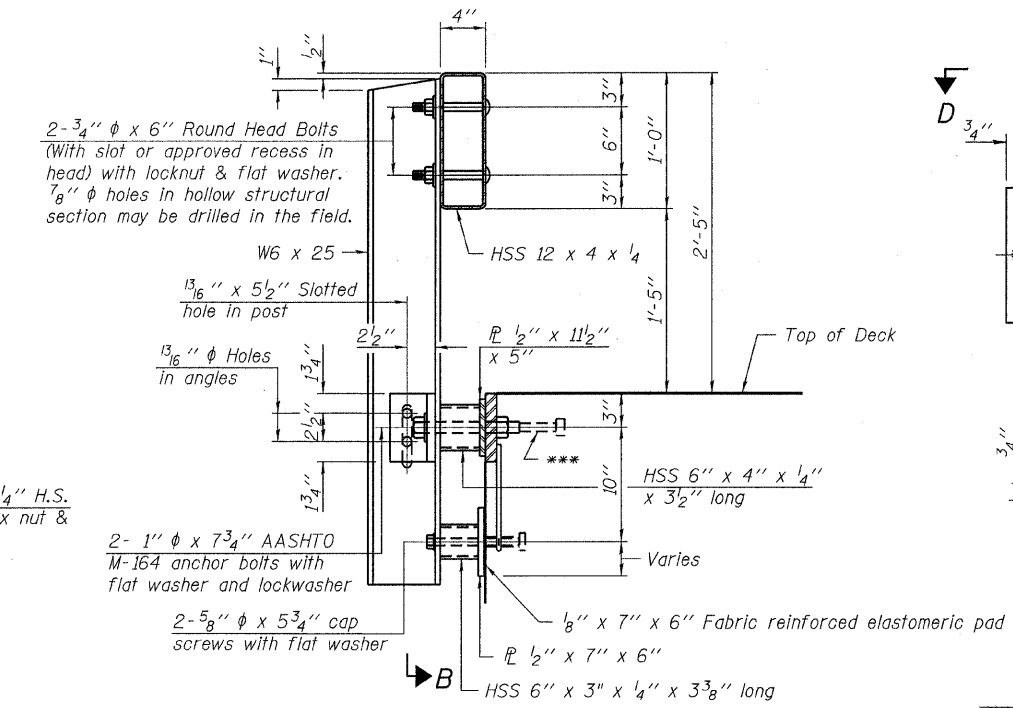

**SECTION AT RAILING POST**

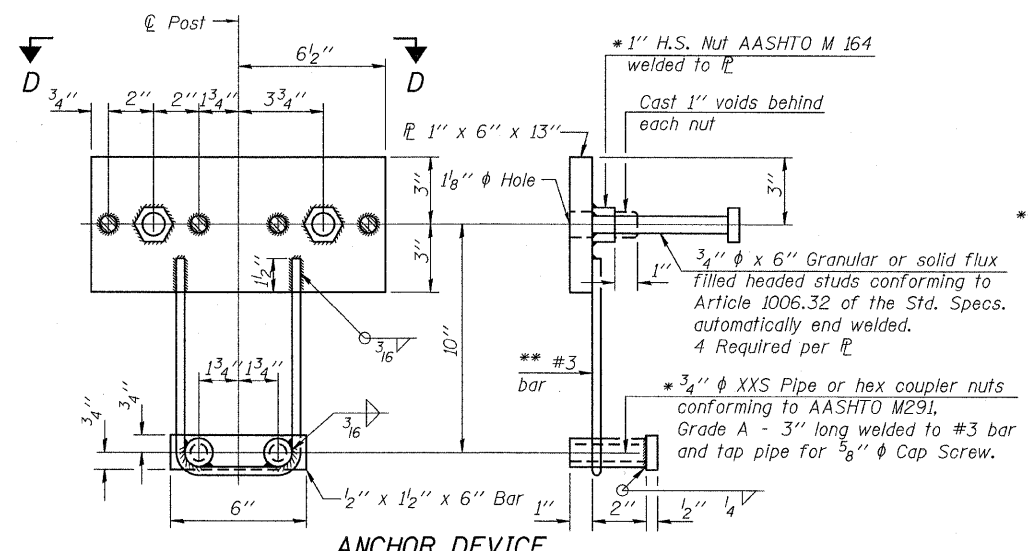

**ANCHOR DEVICE**

Notes:  
All field drilled holes shall be coated with an approved zinc rich paint before erection.  
For multi-span bridges, sufficient 1/4" x 6" x 1'-2" galvanized steel shims shall be provided to align rail between adjacent spans. Cost included with Steel Railing, Type S-1.  
All steel rail elements shall be galvanized according to Article 509.05 of the Standard Specifications.  
\*\*\* The studs of the anchor devices shall be placed below the top reinforcement bars and the outermost longitudinal reinforcement bar shall be placed directly above the studs of the rail post anchor device.

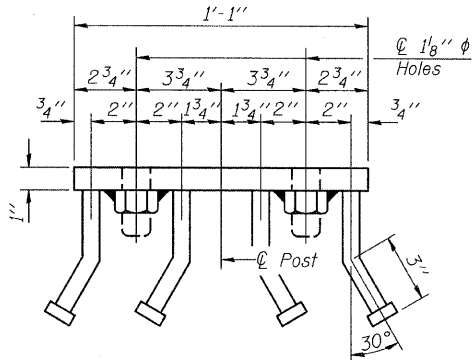

**VIEW D-D**

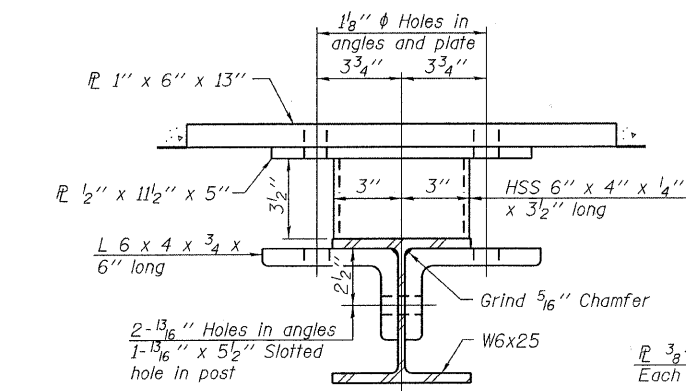

**SECTION C-C**

\*\* Whenever the lower insert assemblies interfere with strand locations, the #3 bars shall be cut and adjusted in order to allow raising or lowering of the lower inserts. Maximum adjustment not to exceed 1/2".

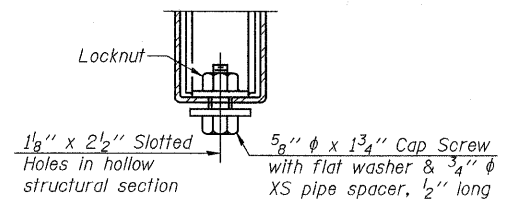

**RAIL SPLICE CONNECTION AT EXPANSION JT.**

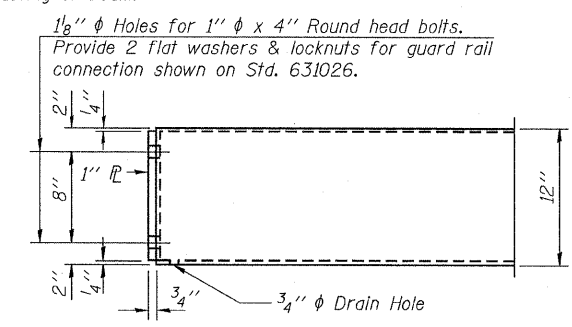

**END OF RAIL DETAILS**

**BILL OF MATERIAL**

Item	Unit	Quantity
Steel Railing, Type S-1	Foot	95

DESIGNED - A.S.L.
CHECKED - S.W.M.
DRAWN - D.A.B.
CHECKED - D.T.M.

R-23A

10-1-08

(10'-9" Maximum Post Spacing)

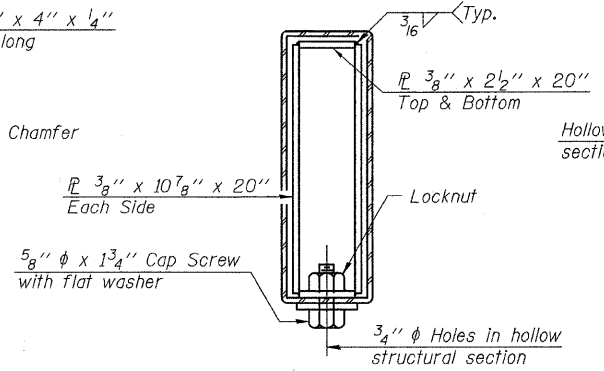

**SECTIONS AT RAIL SPLICE**

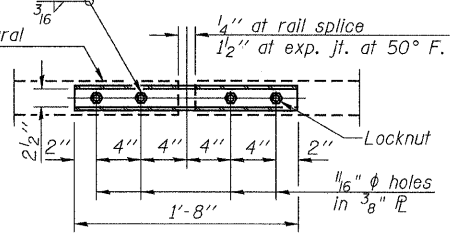

**PLAN-BOTT. SPLICE TYPICAL**

**HAMPTON, LENZINI & RENWICK, INC.**  
CIVIL & STRUCTURAL ENGINEERS  
LAND SURVEYORS

**HLR**  
3085 STEVENSON DRIVE, SUITE 201  
SPRINGFIELD, ILLINOIS 62703  
(217) 546-3400

PROJECT NUMBER: 09.0074.130 DATE: 07/08/09

SHEET NO. 5 9 SHEETS	FAS	SECTION	COUNTY	TOTAL SHEETS	SHEET NO.
	890	08-07120-00-BR	WHITE	12	8
	HERALDS PRAIRIE ROAD DISTRICT		CONTRACT NO. 99408		
FED. ROAD DIST. NO.		ILLINOIS FED. AID PROJECT BROS-0193042			