

**ROADWAY GEOTECHNICAL REPORT**

**US 6 & IL 178 INTERSECTION**

FAP 623 (US 6)

Section (31)N, SFY

District 3 # 2736

P-93-035-11

D-93-011-20

C-93-033-20

Contract 66B52

LaSalle County



Region 2, District 3

Prepared by:

Jeremy Brown

District 3 Geotechnical Engineer

1-815-433-7098

[Jeremy.Brown@Illinois.gov](mailto:Jeremy.Brown@Illinois.gov)

January 24, 2020

## TABLE OF CONTENTS

I.	GENERAL INFORMATION .....	4
A.	Project Location, Description, and Scope.....	4
B.	Existing Pavement Conditions .....	4
C.	Soils.....	4
D.	Pavement Design.....	4
II.	SUBSURFACE INVESTIGATION.....	5
A.	Field Investigation .....	5
B.	Groundwater Conditions .....	5
C.	Laboratory Testing and Classification of Soils .....	6
III.	ANALYSIS AND RECOMMENDATIONS.....	6
A.	Frost Susceptible Soils .....	6
B.	Subgrade Support Rating and Illinois Bearing Ratio.....	6
C.	Geotechnical Reports .....	6
D.	Improved Subgrade .....	6
E.	Slope Stability .....	7
F.	Settlement .....	7
IV.	FURTHER INFORMATION .....	7

## LIST OF APPENDICES

Project Location Map.....	A
Existing and Proposed Typical Sections .....	B
Plan View with Boring Locations.....	C
Existing Roadway Images.....	D
Roadway Soil Boring Logs .....	E
Traffic Signal Boring Logs .....	F
Dynamic Cone Penetrometer Data.....	G
Grain Size Distribution with Atterberg Limits .....	H
IDH Textural Classification Chart .....	I
Subgrade Support Rating Chart .....	J
Geotechnical Reports Special Provision.....	K
Aggregate Subgrade Improvement (District 3) Special Provision.....	L

## **I. GENERAL INFORMATION**

### **A. Project Location, Description, and Scope**

A project location map is provided in Appendix A.

The project is located on US 6 at the intersection with IL 178 In Utica Township, Section 4/5 of T33N, R2E, 3<sup>rd</sup> Principal Meridian, LaSalle County, Illinois.

The proposed improvements include the following:

- Reconstruction of US 6 from STA 278+25 to STA 286+50.
- Reconstruction of IL 178 from STA 88+00 to STA 96+00.

The proposed improvement to the intersection of US 6 and IL 178 will provide a roundabout connecting all four legs of the intersection.

The existing and proposed typical sections are included in Appendix B.

The proposed plan view is included in Appendix C.

### **B. Existing Pavement Conditions**

Both US 6 and IL 178 are two-lane roadways and the pavement leading to the intersection is relatively new and in good condition. The existing pavement in the intersection is deteriorating, however there is no sign of settlement or any other geotechnical issues. Images can be found in Appendix D.

### **C. Soils**

The soils within the project generally consist of silty clay loam till fill. Most of these soils have unconfined compressive strengths greater or equal than 2.0 tons per square foot when measured with a pocket penetrometer. Limestone bedrock is located approximately 22 feet below the existing ground surface.

### **D. Pavement Design**

The proposed pavement consists of 9 inches of jointed PCC pavement, 4 inches of stabilized sub-base, and 12 inches of aggregate subgrade improvement. However, this design has not been approved yet.

## II. SUBSURFACE INVESTIGATION

### A. Field Investigation

A subsurface investigation consisting of dynamic cone penetrometer (DCP) testing and soil sampling with a push tube was executed in July 2019 to determine the immediate bearing value (IBV) of the soils and the physical characteristics of the soils. A summary of all test locations is provided in Table 1. Soil borings for the roadway are shown on the plan sheet in Appendix C and are included in Appendix E. Soil boring logs for the traffic signals at the intersection with IL 178 are shown in Appendix F. DCP data is provided in Appendix G.

Boring Number	Route	Station	Offset Distance (feet)	Offset Direction	Drilling Method	Depth (feet)
101	US 6	278+85.4	24.3	Rt.	Push Tube	6
102	US 6	281+83.5	24.7	Lt.	Push Tube	6
103	US 6	283+64.5	34.3	Rt.	Push Tube	6
104	US 6	286+05.4	39.8	Lt.	Push Tube	6
201	IL 178	87+22.7	33.3	Lt.	Push Tube	6
202	IL 178	94+18.6	24.1	Lt.	Push Tube	6

Table 1: Subsurface Investigation Summary

### B. Groundwater Conditions

Complete precipitation data for the period prior to the subsurface investigation in Utica, Illinois is provided in Table 2. During the subsurface investigation in the fourth week of July 2019, no groundwater was encountered by the drilling crew. Since the seven months prior to the subsurface investigation had more than average precipitation and no groundwater was encountered during subsurface investigations, groundwater is not likely to be encountered during construction.

Month	Year	Actual Precipitation	Normal Precipitation	Departure from Normal (+/-)	Cumulative Actual Precipitation	Cumulative Normal Precipitation
January	2019	2.90	1.50	1.4	2.90	1.50
February	2019	2.44	1.42	1.02	5.34	2.92
March	2019	2.65	2.44	0.21	7.99	5.36
April	2019	3.97	3.23	0.74	11.96	8.59
May	2019	9.92	4.09	5.83	21.88	12.68
June	2019	4.91	3.98	0.93	26.79	16.66
July	2019	4.59	3.86	0.73	31.38	20.52
<b>Totals</b>		<b>31.38</b>	<b>20.52</b>	<b>10.86</b>	<b>31.38</b>	<b>20.52</b>

Table 2: Precipitation Data for Ottawa, Illinois

### **C. Laboratory Testing and Classification of Soils**

For the soil borings, laboratory testing consisted of Atterberg Limits, grain size analysis, and moisture content. The soil samples were classified in accordance with the IDOT textural classification chart and the AASHTO engineering designations with group indices were determined. The grain size distribution with Atterberg Limits is included in Appendix H. The IDH Textural Classification Chart is included in Appendix I.

## **III. ANALYSIS AND RECOMMENDATIONS**

### **A. Frost Susceptible Soils**

The soils within the proposed improvement were analyzed for frost susceptibility in accordance to the criteria outlined in the IDOT Geotechnical Manual (2015). The design frost depth for this project is 42 inches. Frost susceptible soils must exhibit at least 65% of silt and fine sand and a plasticity index less than 12.

The results from analysis indicate that no soils with frost susceptible characteristics were encountered in the subsurface exploration.

### **B. Subgrade Support Rating and Illinois Bearing Ratio**

For the purpose of pavement design, a Subgrade Support Rating (SSR) of poor is recommended for all existing subgrade soils. The SSR charts with data points plotted are in Appendix J. Based on Table 6.3.1-1 of the IDOT Geotechnical Manual (2015 edition), the Illinois Bearing Ratio for the existing project soils can be estimated as 2.

The source of the new embankment material is not known at this time, so a Subgrade Support Rating of poor is recommended for all new embankment materials.

### **C. Geotechnical Reports**

The Roadway Geotechnical Report for this project should be made available to the contractor. A special provision for this is included in Appendix K.

### **D. Improved Subgrade**

Multiple options exist for construction of the improved subgrade, including varying thicknesses of aggregate subgrade improvement, various geotextiles, and chemical treatments of the soil. After considering cost, construction staging, previous experience, and the potential for unexpected soil conditions during construction, 12 inches of aggregate subgrade improvement with geotechnical fabric for ground stabilization is recommended throughout the project. This recommendation is based on a review of the soil boring logs, laboratory data, and DCP test results. A special provision for Aggregate Subgrade Improvement is included in Appendix L.

#### **E. Slope Stability**

Based on the soil borings and the proposed cross sections, slope stability problems are not anticipated. Additional slope stability analyses are not warranted.

#### **F. Settlement**

Based on the proposed cross sections, this project will have very little embankment construction. Therefore, settlement should not be an issue.

#### **IV. FURTHER INFORMATION**

If there are any questions about this report or any additional information is required, please contact the District Geotechnical Engineer.

# Appendix A

## Project Location Map



# Contract 66B52



CANNON PKY

Project Begins

E 800 (E. 8TH RD)

178

LASALLE CO

Project Ends

Project Begins

6

Project Ends

Source: Esri, DigitalGlobe, GeoEye, Earthstar Geographics, CNES/Airbus DS, USDA, USGS, AeroGRID, IGN, and the GIS User Community

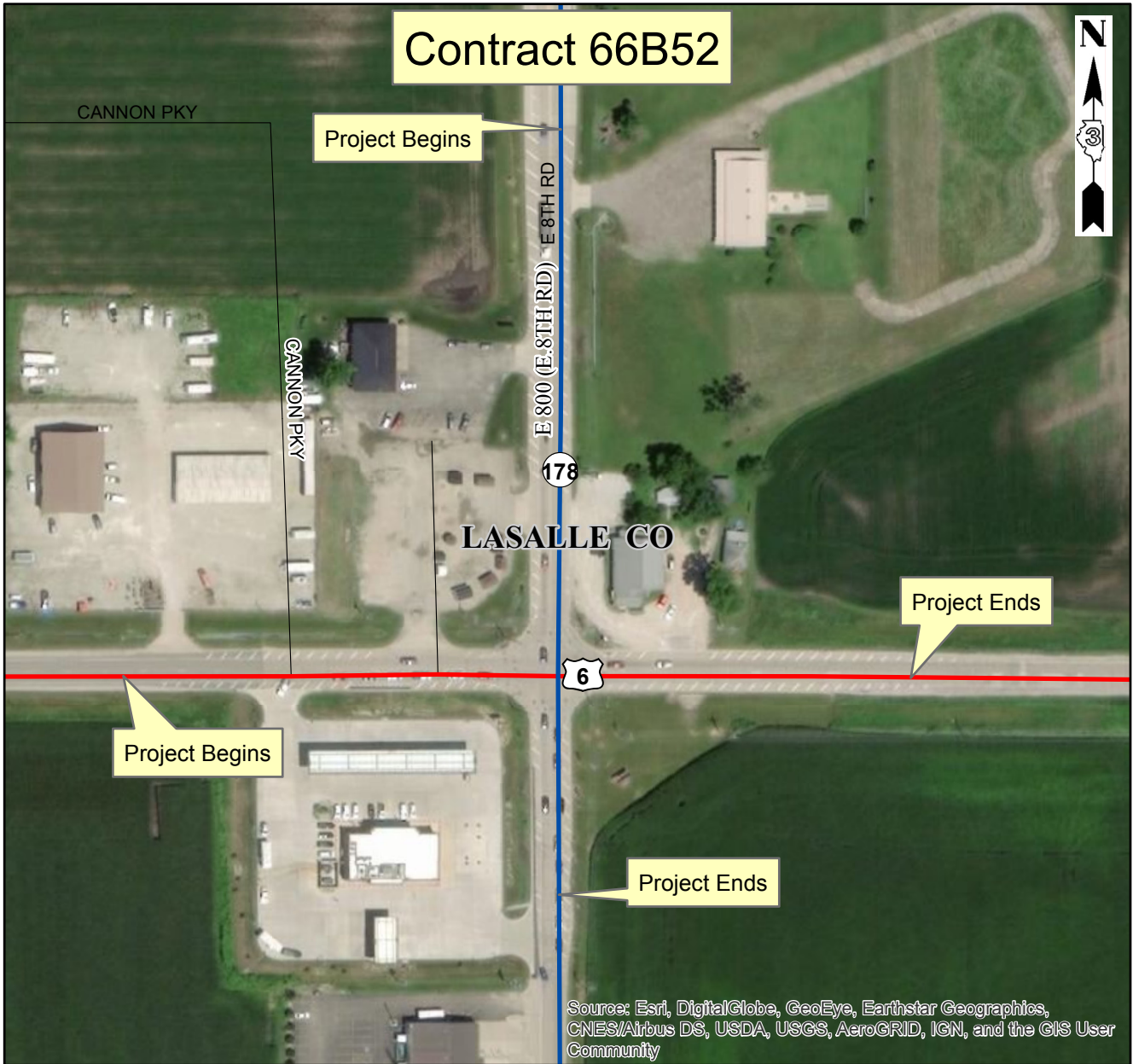

# Appendix B

Existing and Proposed  
Typical Sections

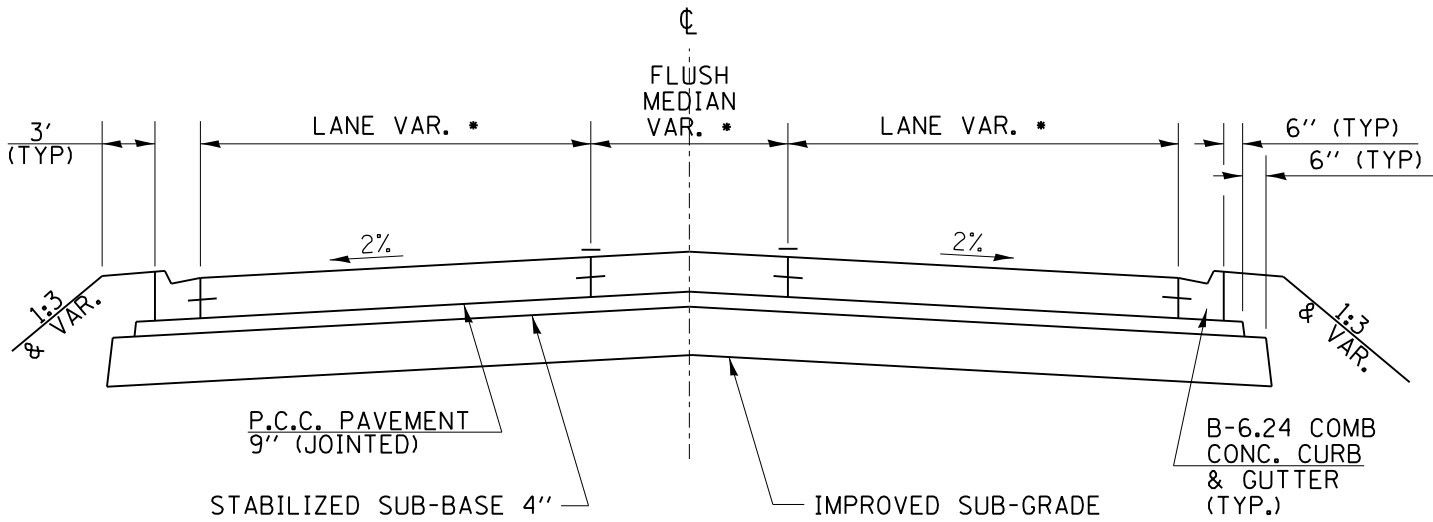

\* LANE AND MEDIAN WIDTHS VARY THROUGHOUT - SEE PLANS

**STA. 278 + 25 TO STA. 281 + 40**  
**STA. 286 + 03 TO STA. 286 + 50**

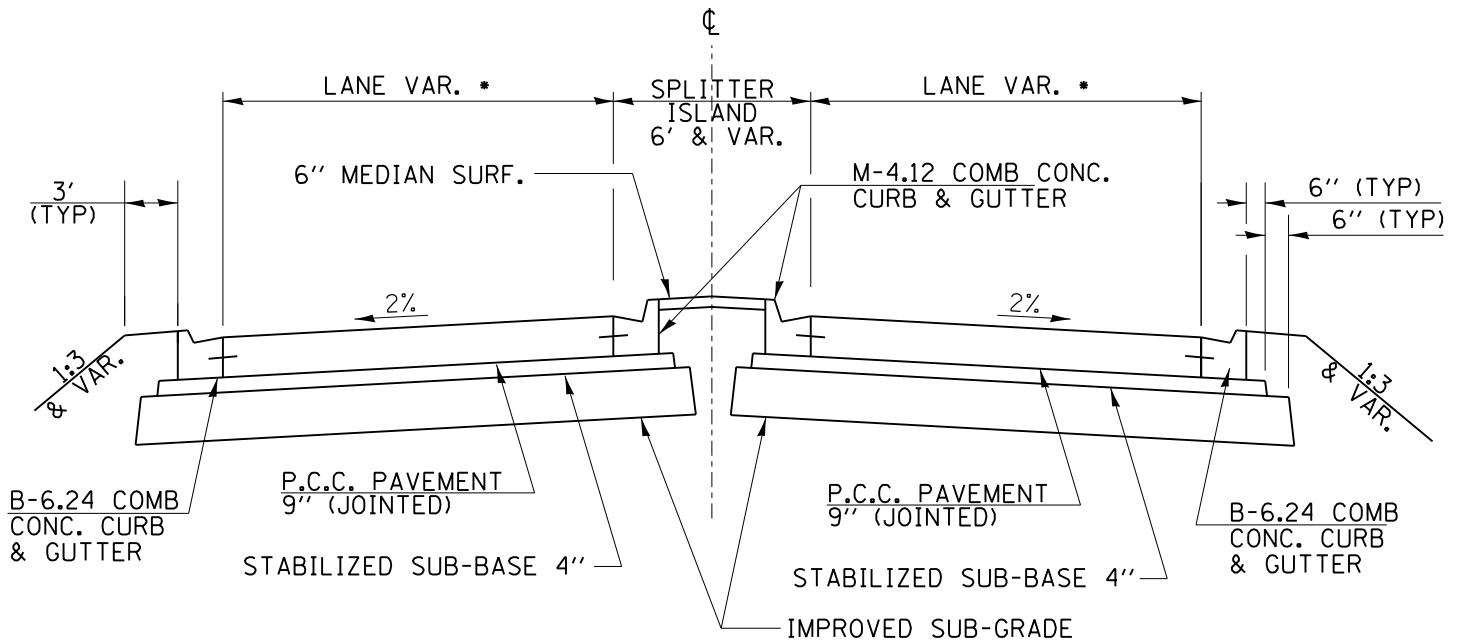

\* LANE AND MEDIAN WIDTHS VARY THROUGHOUT - SEE PLANS

**STA. 281 + 40 TO STA. 282 + 11**  
**STA. 283 + 49 TO STA. 286 + 03**

SPD 12/23/2019

**PROPOSED TYPICAL SECTIONS – U.S. 6**

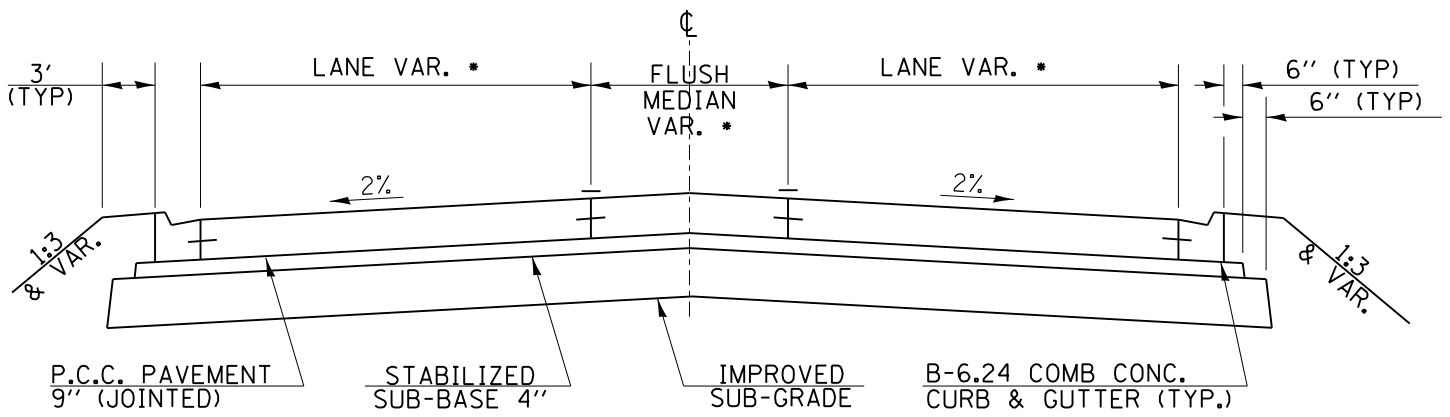

**STA. 88 + 00 TO STA. 88 + 80**  
**STA. 91 + 94 TO STA. 92 + 67.5**

\* LANE AND MEDIAN WIDTHS VARY (SEE PLANS)

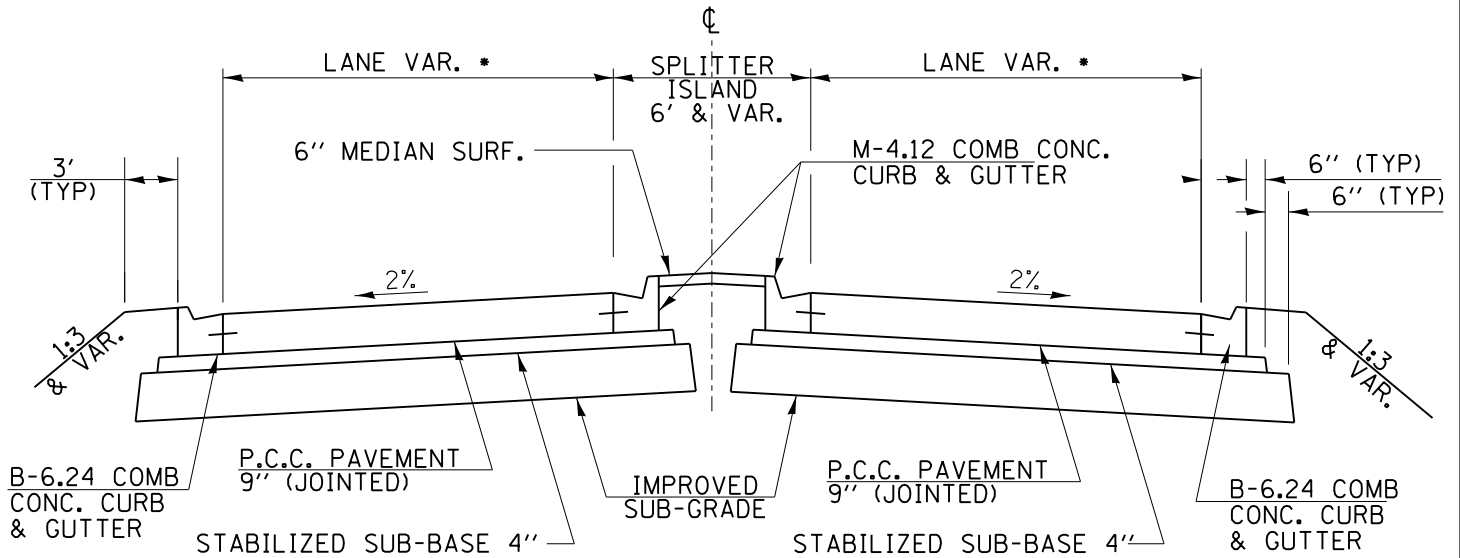

**STA. 88 + 80 TO STA. 89 + 59.15**  
**STA. 90 + 97.15 TO STA. 91 + 94**

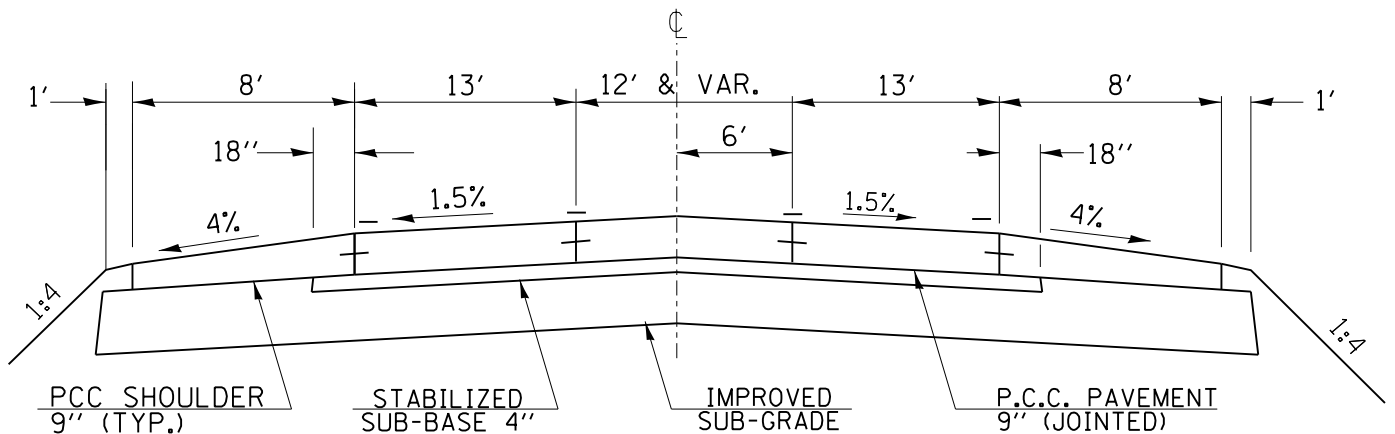

**STA. 92 + 67.5 TO STA. 96 + 00**

**PROPOSED TYPICAL SECTIONS – IL 178**

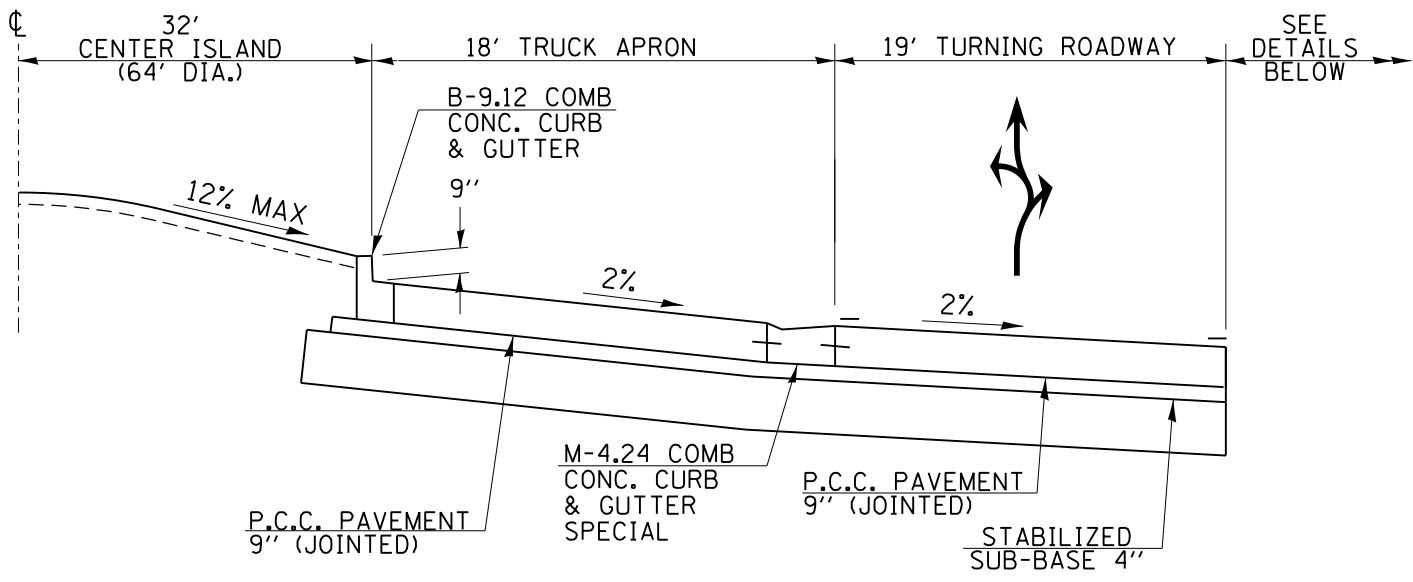

**CENTER ISLAND AND TURNING ROADWAY**

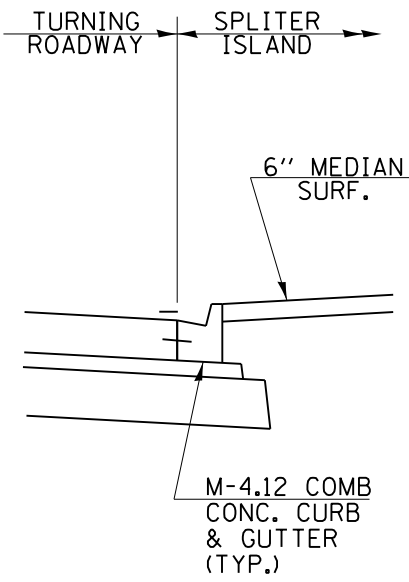

**SPLITTER ISLAND  
DETAIL**

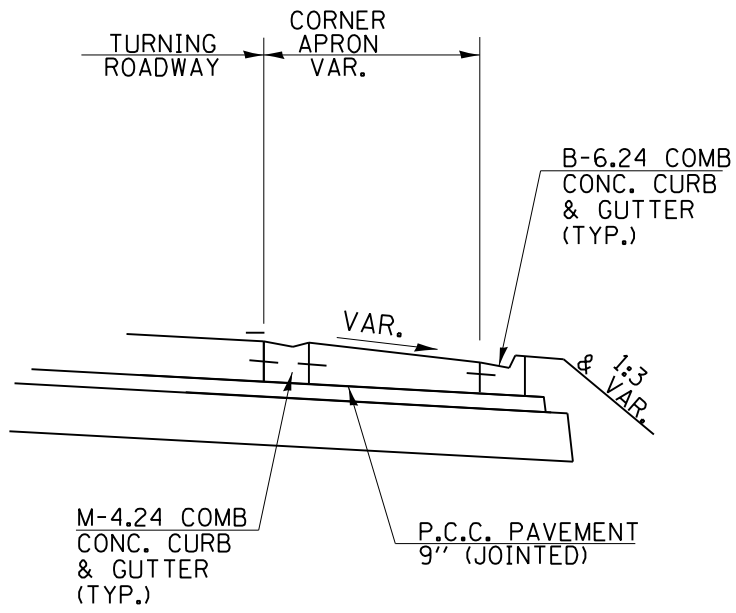

**CORNER APRON  
DETAIL**

SPD 12/23/2019

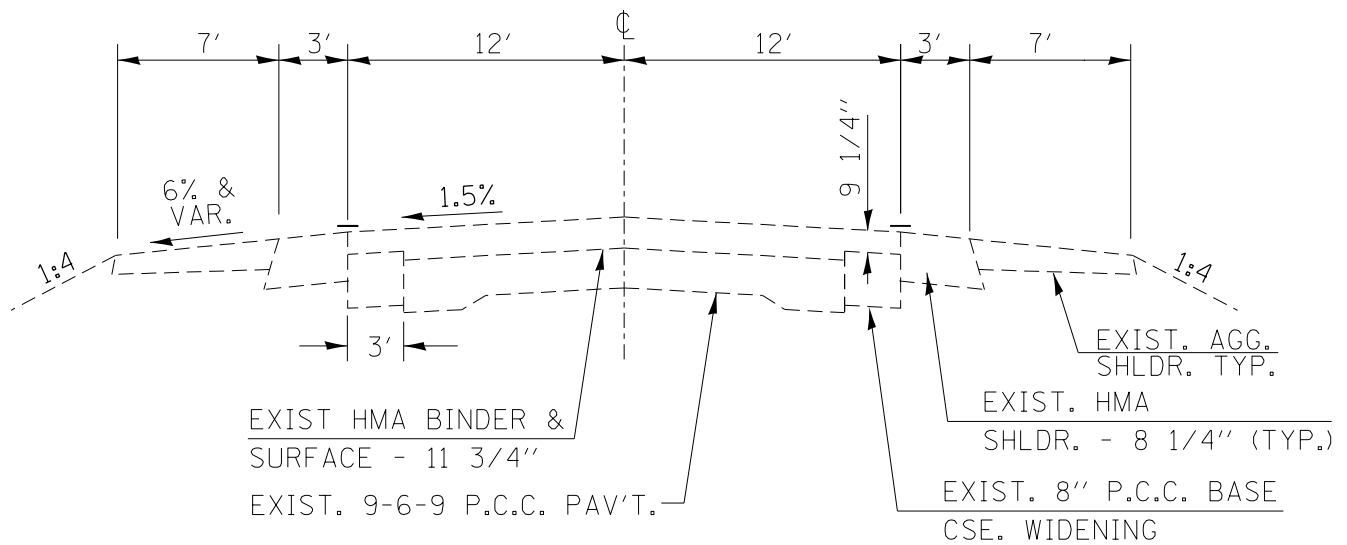

**STA. 271 + 00 TO STA. 279 + 79**  
**STA. 285 + 76 TO STA. 295 + 00**

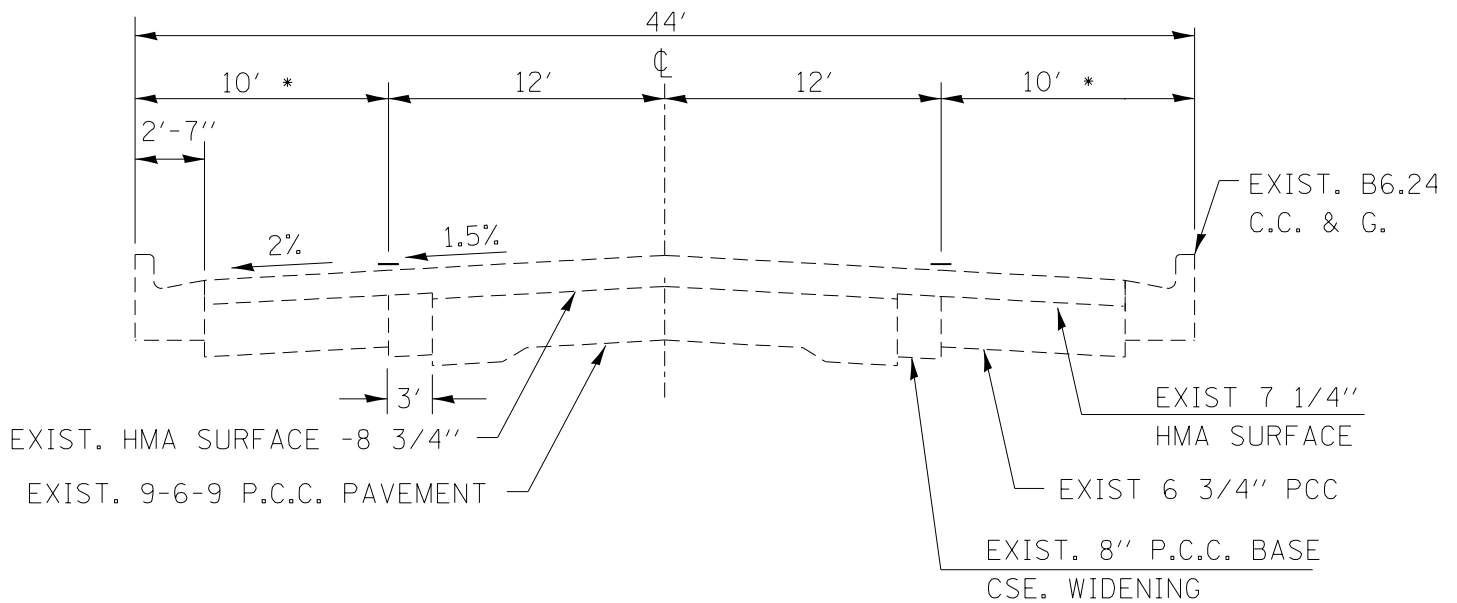

\* WIDTH VARIES IN CORNER RADII

**STA. 279 + 79 TO STA. 285 + 76**

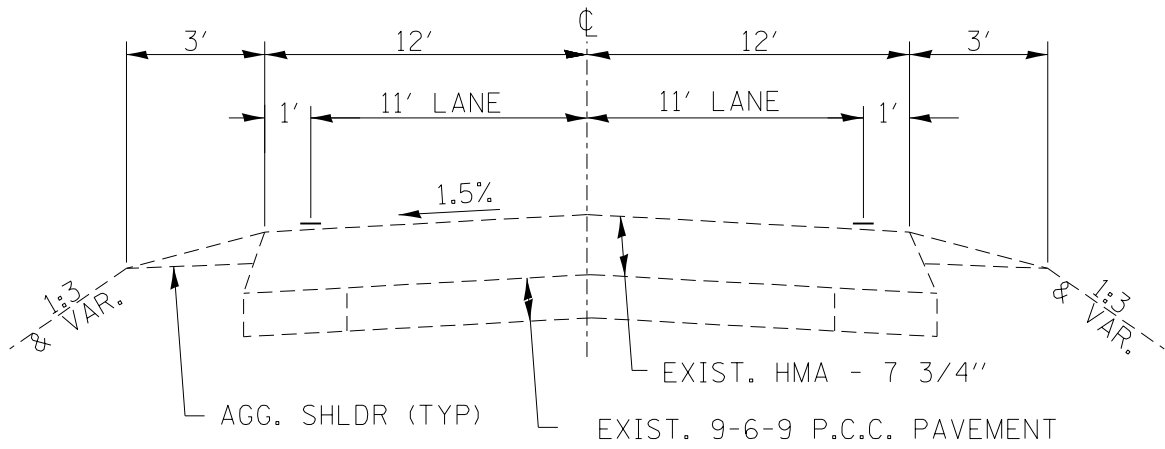

**STA. 81 + 00 TO STA. 87 + 94.3**

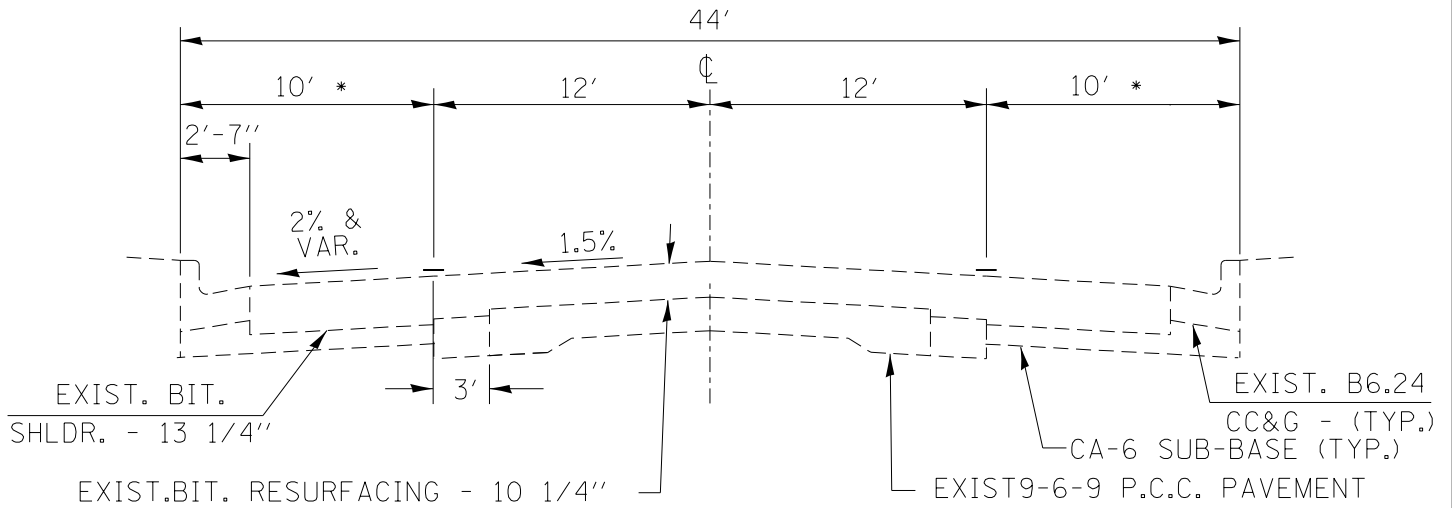

\* WIDTH VARIES IN CORNER RADII

**STA. 87 + 94.3 TO STA. 92 + 48.5**

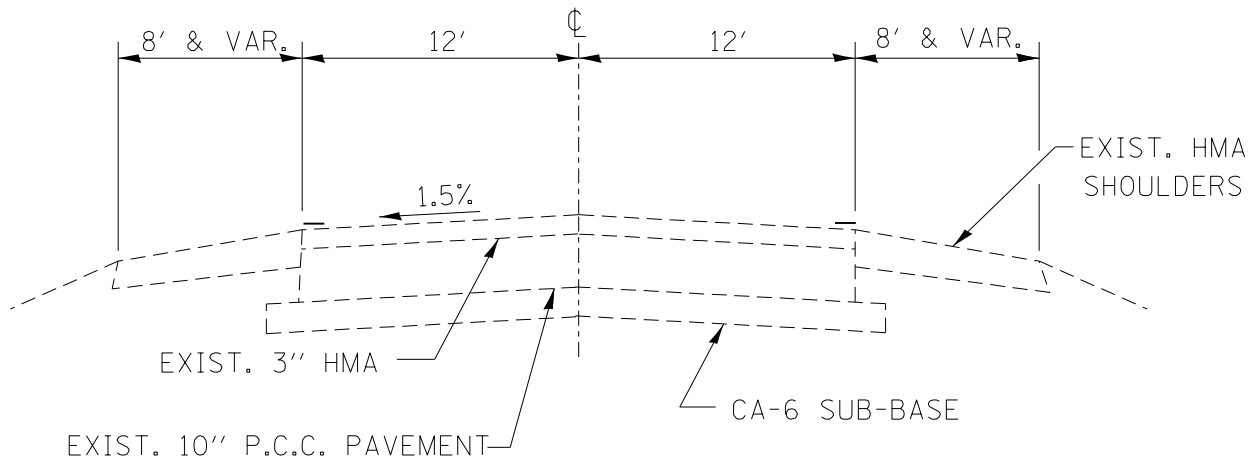

**STA. 92 + 48.5 TO STA. 96 + 00**

**EXISTING TYPICAL SECTIONS - IL 178**

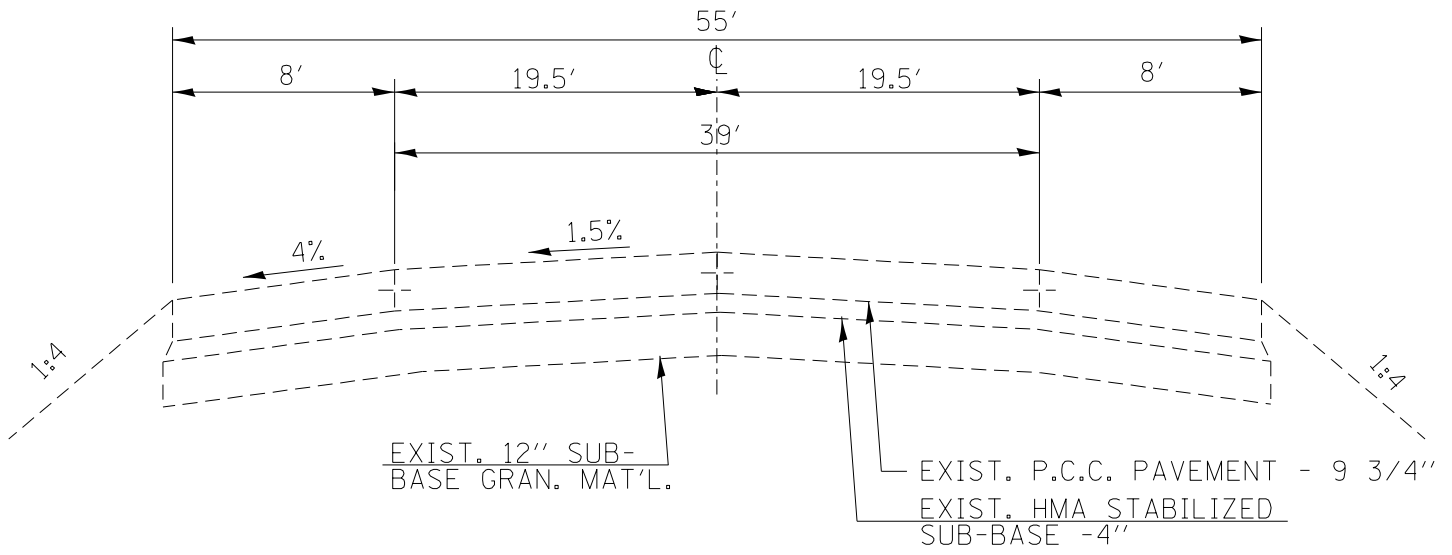

**STA. 96 + 00 TO 103 + 05.46**



# Appendix C

Proposed Plan View with  
Boring Locations

MATCH LINE 95 + 50



MATCH LINE 95 + 50

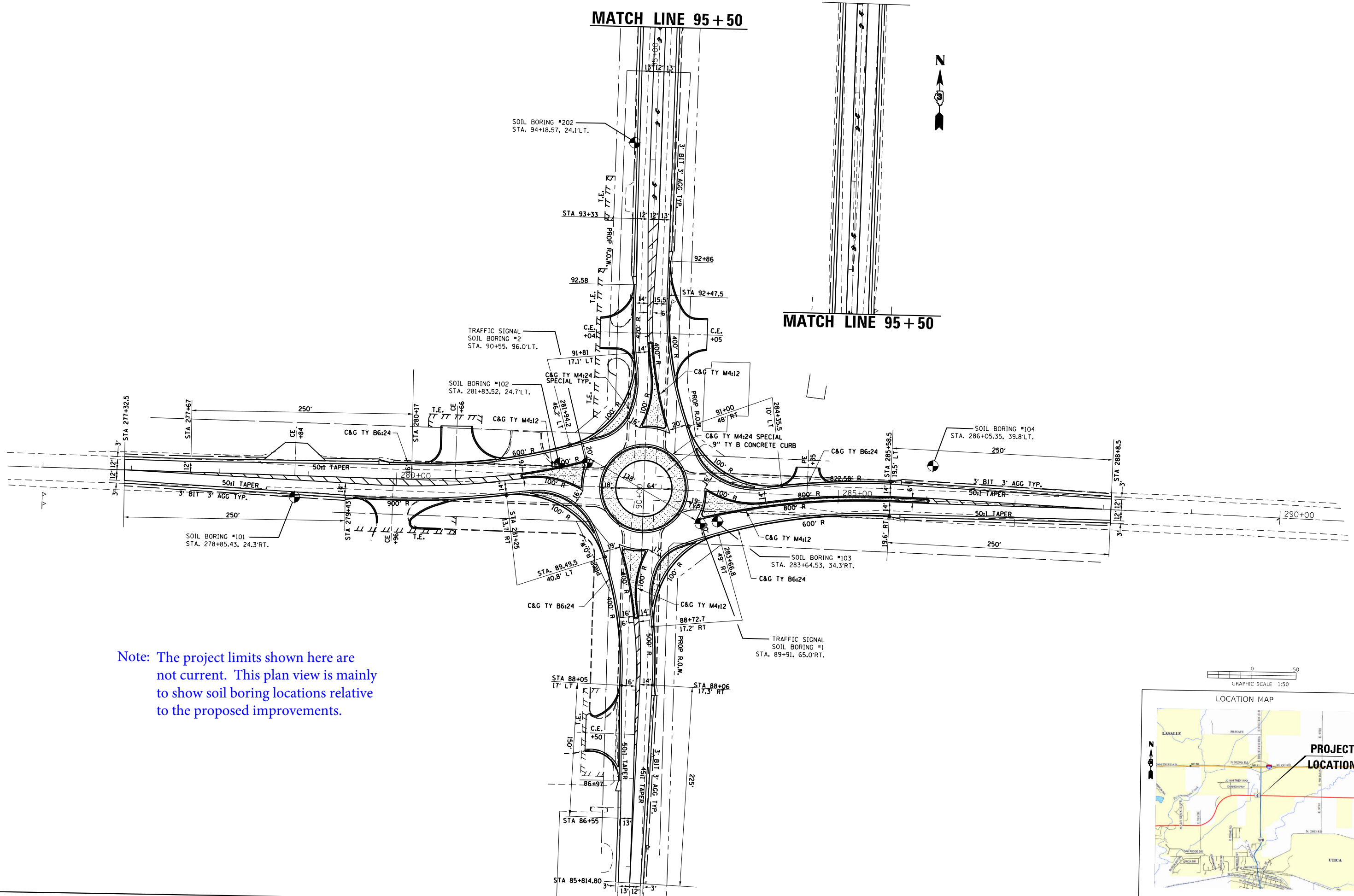

Note: The project limits shown here are not current. This plan view is mainly to show soil boring locations relative to the proposed improvements.

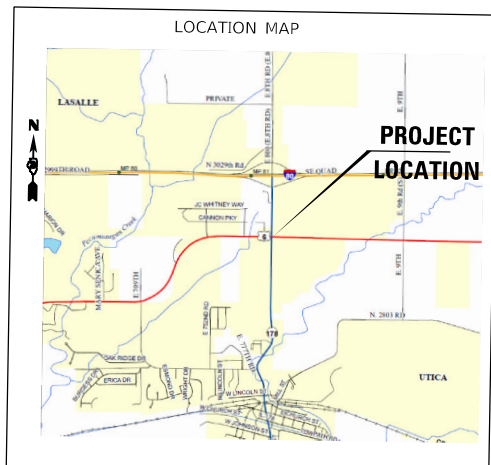
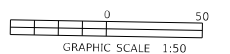

# Appendix D

Images of Existing Roadway  
Conditions



Intersection - Looking East



Intersection - Looking South



US RT 6 - Looking West



US RT 6 - Looking East



IL 178 - Looking North



IL - 178 Looking South

# Appendix E

Roadway Soil Borings  
(FAP 623)



# SOIL BORING LOG

ROUTE US 6 & IL 178 DESCRIPTION \_\_\_\_\_ LOGGED BY Larry Myers  
SECTION (31)N,SFY LOCATION SE 1/4, SEC. 5, TWP. 33N, RNG. 2E, 3<sup>rd</sup> PM,  
Latitude 41.360806, Longitude -89.011638  
COUNTY LaSalle DRILLING METHOD Push HAMMER TYPE CME Automatic

STRUCT. NO. _____	D E P T H	B L O W S	U C S  Qu	M O I S T	Surface Water Elev. _____ ft
Station _____					Stream Bed Elev. _____ ft
BORING NO. <u>101</u>					Groundwater Elev.: _____
Station <u>278+85.43</u>					First Encounter <u>Dry</u> ft
Offset <u>24.3 ft Rt.</u>					Upon Completion _____ ft
Ground Surface Elev. <u>616.22</u> ft	(ft)	(/6")	(tsf)	(%)	After _____ Hrs. _____ ft

Black Silty Clay Loam Fill	615.22						
Brown / Gray Silty Clay Loam Till			3.0 P	26			
		-5					
	610.22		4.0 P	17			
End of Boring							
		-10					
		-15					
		-20					

SOIL BORING SINGLE LANE ROUNDABOUT AT IL 178 & US 6 INTERSECTION IN UTICA.GPJ IL\_DOT\_GDT 12/12/19







# SOIL BORING LOG

ROUTE US 6 & IL 178 DESCRIPTION \_\_\_\_\_ LOGGED BY Larry Myers

SECTION (31)N,SFY LOCATION SW 1/4, SEC. 4, TWP. 33N, RNG. 2E, 3<sup>rd</sup> PM,  
Latitude 41.360761, Longitude -89.009894

COUNTY LaSalle DRILLING METHOD Push HAMMER TYPE CME Automatic

STRUCT. NO. _____ Station _____	D E P T H  H	(ft)	B L O W S  S	U C S  Qu	M O I S T  T	Surface Water Elev. _____ ft
						Stream Bed Elev. _____ ft
BORING NO. <u>103</u> Station <u>283+64.53</u> Offset <u>34.3 ft Rt.</u>						Groundwater Elev.: First Encounter <u>Dry</u> ft
Ground Surface Elev. <u>618.67</u> ft						Upon Completion _____ ft After _____ Hrs. _____ ft

Black Silty Clay Loam Fill with Gravel Pieces	617.17		3.0	11	
Black Silty Clay Loam Topsoil	615.67		P		
Brown Silty Clay Loess			2.5	24	
			P		
		-5			
	612.67		1.5	26	
			P		
End of Boring					
		-10			
		-15			
		-20			

SOIL BORING SINGLE LANE ROUNDABOUT AT IL 178 & US 6 INTERSECTION IN UTICA.GPJ IL\_DOT\_GDT 12/12/19



**Illinois Department of Transportation**

Division of Highways  
Illinois Department of Transportation

# SOIL BORING LOG

ROUTE US 6 & IL 178 DESCRIPTION Sample #1 LOGGED BY Larry Myers

SECTION (31)N,SFY LOCATION NW 1/4, SEC. 4, TWP. 33N, RNG. 2E, 3<sup>rd</sup> PM,  
Latitude 41.360951, Longitude -89.009012

COUNTY LaSalle DRILLING METHOD Push HAMMER TYPE CME Automatic

<b>STRUCT. NO.</b> _____ Station _____	D E P T H			<b>Surface Water Elev.</b> _____ ft	
		<b>Stream Bed Elev.</b> _____ ft			
<b>BORING NO.</b> <u>104</u> Station <u>286+05.35</u> Offset <u>39.8 ft Lt.</u>		(ft)	(tsf)	(%)	<b>Groundwater Elev.:</b>
					<b>First Encounter</b> <u>Dry</u> ft
<b>Ground Surface Elev.</b> <u>615.60</u> ft				<b>Upon Completion</b> _____ ft	
				<b>After</b> _____ Hrs. _____ ft	

Description	(ft)	(tsf)	(%)
Black Silty Clay Loam Topsoil Fill	615.10		
Brown & Gray Silty Clay Loess		2.0 P	16
	613.60		
Brown Silty Clay Loam Till with Loamy Gravel Layers		2.5 P	25
	-5		
	609.60	2.5 P	15
End of Boring			
	-10		
	-15		
	-20		

--	--

SOIL BORING SINGLE LANE ROUNDABOUT AT IL 178 & US 6 INTERSECTION IN UTICA.GPJ IL\_DOT\_GDT 12/12/19

The Unconfined Compressive Strength (UCS) Failure Mode is indicated by (B-Bulge, S-Shear, P-Penetrometer)  
The SPT (N value) is the sum of the last two blow values in each sampling zone (AASHTO T206)



**Illinois Department of Transportation**

Division of Highways  
Illinois Department of Transportation

**SOIL BORING LOG**

Page 1 of 1

Date 7/25/19

ROUTE US 6 & IL 178 DESCRIPTION \_\_\_\_\_ Sample #2 LOGGED BY Larry Myers

SECTION (31)N,SFY LOCATION NE 1/4, SEC. 5, TWP. 33N, RNG. 2E, 3<sup>rd</sup> PM,  
Latitude 41.361931, Longitude -89.010272

COUNTY LaSalle DRILLING METHOD Push HAMMER TYPE CME Automatic

STRUCT. NO. \_\_\_\_\_  
Station \_\_\_\_\_

BORING NO. 202  
Station 94+18.57  
Offset 24.1 ft Lt.  
Ground Surface Elev. 618.68 ft

D E P T H	B L O W S	U C S  Qu	M O I S T
(ft)	(/6")	(tsf)	(%)

Surface Water Elev. \_\_\_\_\_ ft  
Stream Bed Elev. \_\_\_\_\_ ft  
Groundwater Elev.:  
First Encounter Dry ft  
Upon Completion \_\_\_\_\_ ft  
After \_\_\_\_\_ Hrs. \_\_\_\_\_ ft

Black, Brown Silty Clay Loam Fill with Asphalt Chunks

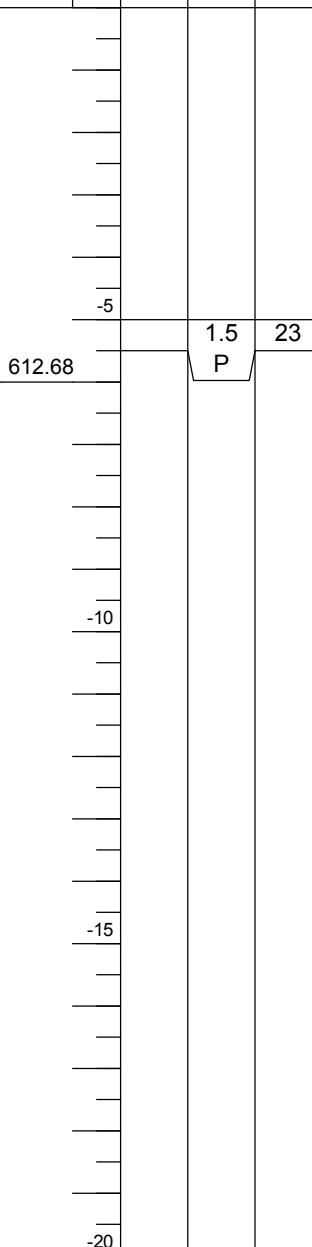

1.5  
P  
23

612.68

End of Boring

SOIL BORING SINGLE LANE ROUNDABOUT AT IL 178 & US 6 INTERSECTION IN UTICA, GPJ IL\_DOT\_GDT 12/12/19

The Unconfined Compressive Strength (UCS) Failure Mode is indicated by (B-Bulge, S-Shear, P-Penetrometer)  
The SPT (N value) is the sum of the last two blow values in each sampling zone (AASHTO T206)

# Appendix F

## Traffic Signal Borings



# SOIL BORING LOG

ROUTE US 6 / IL 178 DESCRIPTION Intersection of US 6 with IL 178 at Utica LOGGED BY Larry Myers

SECTION (31)N LOCATION NW 1/4 of SW 1/4, SEC. 4, TWP. 33N, RNG. 2E, 3<sup>rd</sup> PM,  
Latitude 41.360753, Longitude -89.009963

COUNTY LaSalle DRILLING METHOD Hollow Stem Auger HAMMER TYPE CME Automatic

STRUCT. NO. Station	D E P T H ft	B L O W S Qu	U C S Qu	M O I S T %	Surface Water Elev.	D E P T H ft	B L O W S Qu	U C S Qu	M O I S T %
					ft				
BORING NO. <u>1 (S.E. Quad.)</u> Station <u>89+91 (IL 178)</u> Offset <u>65.0 ft Rt.</u> Ground Surface Elev. <u>618.49</u>	ft	(ft)	(/6")	(tsf)	(%)	Groundwater Elev.:	ft	ft	ft
Ground Surface Elev.	ft	(ft)	(/6")	(tsf)	(%)	First Encounter	Dry	ft	ft
						Upon Completion	Dry	ft	ft
						After	Hrs.	ft	ft
Augered Black Silty Clay Loam Fill with Gravel pieces / Layers - Fill						Dense Light Tan Fine to Coarse Silica Sand			
								12	
								16	5
								20	
615.99							595.99		
Very Stiff Black & Brown Silty Clay Loam Fill with Gravel pieces		4				Auger Refusal at 22.5'	595.91	100/1'	
		5	3.0	26		Rock Surface - White Limestone			
		5	P			End of Boring			
613.99									
Stiff Brown & Gray Silty Clay / Loam with Sand & Gravel Layers (Fill?)									
	-5	3						-25	
		3	2.0	15					
		3	P						
611.49									
Very Stiff Brown & Gray Silty Clay Loam Till		2							
		3	2.4	20					
		3	B						
608.99									
Hard Brown Silty Clay Loam Till									
	-10	7						-30	
		11	6.9	16					
		16	S						
		5							
		7	7.0	4					
		11	S						
603.99									
Hard Gray Silty Clay Loam Till									
	-15	9						-35	
		11	10.3	14					
		14	S*						
		5							
		8	10.3	15					
		11	S*						
598.49	-20							-40	

SOIL BORING US 6 & IL 178 INTERSECTION IN UTICA.GPJ IL\_DOT.GDT 12/12/19

The Unconfined Compressive Strength (UCS) Failure Mode is indicated by (B-Bulge, S-Shear, P-Penetrometer)  
 The SPT (N value) is the sum of the last two blow values in each sampling zone (AASHTO T206)  
 BBS, form 137 (Rev. 8-99)



# SOIL BORING LOG

ROUTE US 6 / IL 178 DESCRIPTION Intersection of US 6 with IL 178 at Utica LOGGED BY Larry Myers

SECTION (31)N LOCATION SE 1/4 of NE 1/4, SEC. 5, TWP. 33N, RNG. 2E, 3<sup>rd</sup> PM,  
Latitude 41.360944, Longitude -89.010559

COUNTY LaSalle DRILLING METHOD Hollow Stem Auger HAMMER TYPE CME Automatic

STRUCT. NO. Station	D E P T H  H	B L O W S	U C S  Qu	M O I S T  T	Surface Water Elev. _____ ft	Stream Bed Elev. _____ ft	D E P T H  H	B L O W S	U C S  Qu	M O I S T  T
BORING NO. <u>2 (N.W. Quad.)</u> Station <u>90+55 (IL 178)</u> Offset <u>96.0 ft Lt.</u> Ground Surface Elev. <u>617.67</u> ft					Groundwater Elev.:	Groundwater Elev.:				
					First Encounter _____ Dry ft	First Encounter _____ Dry ft				
					Upon Completion _____ Dry ft	Upon Completion _____ Dry ft				
					After _____ Hrs. _____ ft	After _____ Hrs. _____ ft				
Augered Black Silty Clay Loam Fill with Gravel pieces 615.17					Dense to Medium Light Tan Fine / Coarse Silica Sand (continued)		9			6
							10			
							12			
							595.17			
Very Stiff Black Silty Clay Loam & Brown / Gray Silty Clay Fill 613.17		4			Auger Refusal at 22.5' White Limestone		594.67	35		3
		3	2.0	24	End of Boring			100/0'		
		3	P							
Very Stiff Brown & Gray Silty Clay Loam Till 610.67	-5						-25			
		3								
		2	3.5	19						
		3	P							
Hard Brown Silty Clay Loam Till 605.67		5								
		7	6.2	16						
		9	S							
	-10						-30			
		7								
		9	6.4	16						
		13	S							
Hard Gray Silty Clay Loam Till 601.17		6								
		8	5.4	16						
		10	S							
	-15						-35			
		5								
		8	6.7	15						
		20	S							
Dense to Medium Light Tan Fine / Coarse Silica Sand 601.17		12								
		18		4						
		20								
	-20						-40			

SOIL BORING US 6 & IL 178 INTERSECTION IN UTICA.GPJ\_IL\_DOT\_GDT 12/12/19

The Unconfined Compressive Strength (UCS) Failure Mode is indicated by (B-Bulge, S-Shear, P-Penetrometer)  
The SPT (N value) is the sum of the last two blow values in each sampling zone (AASHTO T206)

# Appendix G

## Dynamic Cone Penetrometer Testing



US 6 & IL 178 in Utica DCP		Note: Field Measurements taken on ENTER DATE HERE.								IBV < 1		2 < IBV < 3				
										1 < IBV < 2		IBV > 3				
DCP NUMBER	Boring #101				Boring #102				Boring #103				Boring #104			
ELEVATION																
STATION	279+00				282+00				283+65				287+00			
OFFSET	24' Rt.				25' Lt.				30' Rt.				30' Lt.			
BLOWS	DEPTH	IN / BLOW	DEPTH (in)	IBV	DEPTH	IN / BLOW	DEPTH (in)	IBV	DEPTH	IN / BLOW	DEPTH (in)	IBV	DEPTH	IN / BLOW	DEPTH (in)	IBV
0	2.5	0			2.0	0			2.0	0			2.0	0		
1	5.0	2.5	2.5	2.2	3.0	1.0	1.0	6.9	3.1	1.1	1.1	6.14	4.5	2.5	2.5	2.18
2	6.9	1.9	4.4	3.1	3.5	0.50	1.5	16.57	3.7	0.60	1.7	13.17	7.9	3.40	5.9	1.48
3	8.6	1.7	6.1	3.5	4.0	0.50	2.0	16.57	4.2	0.50	2.2	16.57	10.3	2.40	8.3	2.30
4	9.7	1.1	7.2	6.1	4.4	0.40	2.4	21.95	4.6	0.40	2.6	21.95	12.2	1.90	10.2	3.08
5	10.4	0.7	7.9	10.8	4.8	0.40	2.8	21.95	5.0	0.40	3.0	21.95	14.1	1.90	12.1	3.08
6	11.1	0.7	8.6	10.8	5.2	0.40	3.2	21.95	5.4	0.40	3.4	21.95	16.0	1.90	14.0	3.08
7	11.7	0.6	9.2	13.2	5.5	0.30	3.5	31.54	5.6	0.20	3.6	52.57	18.2	2.20	16.2	2.56
8	12.8	1.1	10.3	6.1	6.0	0.50	4.0	16.57	6.2	0.60	4.2	13.17	22.1	3.90	20.1	1.25
9	15.2	2.4	12.7	2.3	6.3	0.30	4.3	31.54	6.7	0.50	4.7	16.57	23.0	0.90	21.0	7.90
10	18.6	3.4	16.1	1.5	6.7	0.40	4.7	21.95	7.2	0.50	5.2	16.57	24.9	1.90	22.9	3.08
11	21.5	2.9	19.0	1.8	7.2	0.50	5.2	16.57	7.6	0.40	5.6	21.95	27.0	2.10	25.0	2.72
12	24.0	2.5	21.5	2.2	7.6	0.40	5.6	21.95	8.1	0.50	6.1	16.57	28.3	1.30	26.3	4.97
13	26.6	2.6	24.1	2.1	8.1	0.50	6.1	16.57	8.6	0.50	6.6	16.57	31.1	2.80	29.1	1.89
14	29.0	2.4	26.5	2.3	8.5	0.40	6.5	21.95	9.1	0.50	7.1	16.57	33.0	1.90	31.0	3.08
15	31.5	2.5	29.0	2.2	8.8	0.30	6.8	31.54	9.6	0.50	7.6	16.57	35.3	2.30	33.3	2.42
16	34.0	2.5	31.5	2.2	9.1	0.30	7.1	31.54	10.0	0.40	8.0	21.95	36.6	1.30	34.6	4.97
17	36.5	2.5	34.0	2.2	9.4	0.30	7.4	31.54	10.5	0.50	8.5	16.57	40.4	3.80	38.4	1.29
18	40.2	3.7	37.7	1.3	9.8	0.40	7.8	21.95	10.9	0.40	8.9	21.95	42.4	2.00	40.4	2.89
19	42.0	1.8	39.5	3.3	10.1	0.30	8.1	31.54	11.2	0.30	9.2	31.54				
20					10.5	0.40	8.5	21.95	11.6	0.40	9.6	21.95				
21					11.0	0.50	9.0	16.57	12.0	0.40	10.0	21.95				
22					11.6	0.60	9.6	13.17	12.4	0.40	10.4	21.95				
23					12.2	0.60	10.2	13.17	13.2	0.80	11.2	9.16				
24					13.0	0.80	11.0	9.16	13.6	0.40	11.6	21.95				
25					13.5	0.50	11.5	16.57	14.0	0.40	12.0	21.95				
26					14.0	0.50	12.0	16.57	14.6	0.60	12.6	13.17				
27					14.6	0.60	12.6	13.17	15.1	0.5	13.1	16.6				
28					14.9	0.30	12.9	31.54	15.7	0.6	13.7	13.2				
29					15.4	0.50	13.4	16.57	16.4	0.7	14.4	10.8				
30					15.8	0.40	13.8	21.95	17.3	0.9	15.3	7.9				
31					16.0	0.20	14.0	52.57	18.0	0.7	16.0	10.8				
32					16.5	0.50	14.5	16.57	18.7	0.7	16.7	10.8				
33					17.0	0.5	15.0	16.6	19.7	1.0	17.7	6.9				
34					17.3	0.3	15.3	31.5	20.8	1.1	18.8	6.1				
35					17.8	0.5	15.8	16.6	22.0	1.2	20.0	5.5				
36					18.2	0.4	16.2	21.9	23.1	1.1	21.1	6.1				
37					18.5	0.3	16.5	31.5	24.3	1.2	22.3	5.5				
38					19.0	0.5	17.0	16.6	25.7	1.4	23.7	4.5				
39					19.3	0.3	17.3	31.5	27.0	1.3	25.0	5.0				
40					20.0	0.7	18.0	10.8	27.9	0.9	25.9	7.9				
41					20.5	0.5	18.5	16.6	28.6	0.7	26.6	10.8				
42					21.0	0.5	19.0	16.6	29.8	1.2	27.8	5.5				
43					21.6	0.6	19.6	13.2	31.3	1.5	29.3	4.2				
44					22.2	0.6	20.2	13.2	33.1	1.8	31.1	3.3				
45					22.7	0.5	20.7	16.6	34.9	1.8	32.9	3.3				
46					23.0	0.3	21.0	31.5	36.6	1.7	34.6	3.5				
47					23.4	0.4	21.4	21.9	38.7	2.1	36.7	2.7				
48					23.8	0.4	21.8	21.9	40.0	1.3	38.0	5.0				
49					24.3	0.5	22.3	16.6	43.0	3.0	41.0	1.7				
50					24.5	0.2	22.5	52.6								
51					25.0	0.5	23.0	16.6								
52					25.5	0.5	23.5	16.6								
53					26.0	0.5	24.0	16.6								
54					27.0	1.0	25.0	6.9								
55					27.5	0.5	25.5	16.6								
56					28.5	1.0	26.5	6.9								
57					29.3	0.8	27.3	9.2								
58					30.5	1.2	28.5	5.5								
59					32.0	1.5	30.0	4.2								
60					33.5	1.5	31.5	4.2								
61					36.0	2.5	34.0	2.2								
62					38.7	2.7	36.7	2.0								
63					42.0	3.3	40.0	1.5								

US 6 & IL 178 in Utica DCP		IBV < 1 1 < IBV < 2				2 < IBV < 3 IBV > 3			
DCP NUMBER	Boring #201				Boring #202				
ELEVATION					094+00				
STATION					25' Lt.				
OFFSET									
BLOWS	DEPTH	IN / BLOW	DEPTH (in)	IBV	DEPTH	IN / BLOW	DEPTH (in)	IBV	
0	1.9	0			2.0	0			
1	3.0	1.1	1.1	6.14	3.8	1.8	1.8	3.30	
2	4.0	1.00	2.1	6.92	4.7	0.90	2.7	7.90	
3	4.9	0.90	3.0	7.90	5.2	0.50	3.2	16.57	
4	5.6	0.70	3.7	10.84	6.0	0.80	4.0	9.16	
5	6.6	1.00	4.7	6.92	6.6	0.60	4.6	13.17	
6	7.8	1.20	5.9	5.50	7.2	0.60	5.2	13.17	
7	9.2	1.40	7.3	4.53	8.2	1.00	6.2	6.92	
8	11.0	1.80	9.1	3.30	9.3	1.10	7.3	6.14	
9	13.0	2.00	11.1	2.89	10.3	1.00	8.3	6.92	
10	15.0	2.00	13.1	2.89	11.6	1.30	9.6	4.97	
11	17.3	2.30	15.4	2.42	13.7	2.10	11.7	2.72	
12	20.2	2.90	18.3	1.81	17.0	3.30	15.0	1.54	
13	24.5	4.30	22.6	1.10	19.3	2.30	17.3	2.42	
14	28.1	3.60	26.2	1.38	22.0	2.70	20.0	1.98	
15	30.4	2.30	28.5	2.42	24.2	2.20	22.2	2.56	
16	33.0	2.60	31.1	2.08	27.0	2.80	25.0	1.89	
17	35.5	2.50	33.6	2.18	28.7	1.70	26.7	3.55	
18	37.9	2.40	36.0	2.30	31.0	2.30	29.0	2.42	
19	40.3	2.40	38.4	2.30	33.0	2.00	31.0	2.89	
20					35.0	2.00	33.0	2.89	
21					36.9	1.90	34.9	3.08	
22					38.5	1.60	36.5	3.83	
23					40.0	1.50	38.0	4.15	
24					41.2	1.20	39.2	5.50	
25					42.4	1.20	40.4	5.50	
26									
27									
28									
29									
30									
31									
32									
33									
34									
35									
36									
37									
38									
39									
40									
41									
42									
43									
44									
45									
46									
47									
48									
49									
50									
51									
52									
53									
54									
55									
56									
57									
58									
59									
60									
61									
62									
63									

# Appendix H

Grain Size Distribution with  
Atterberg Limits

GRAIN SIZE IDH-3-18-11 SINGLE LANE ROUNDABOUT AT IL 178 & US 6 INTERSECTION IN UTICA.GPJ IL DOT.GDT 12/9/19

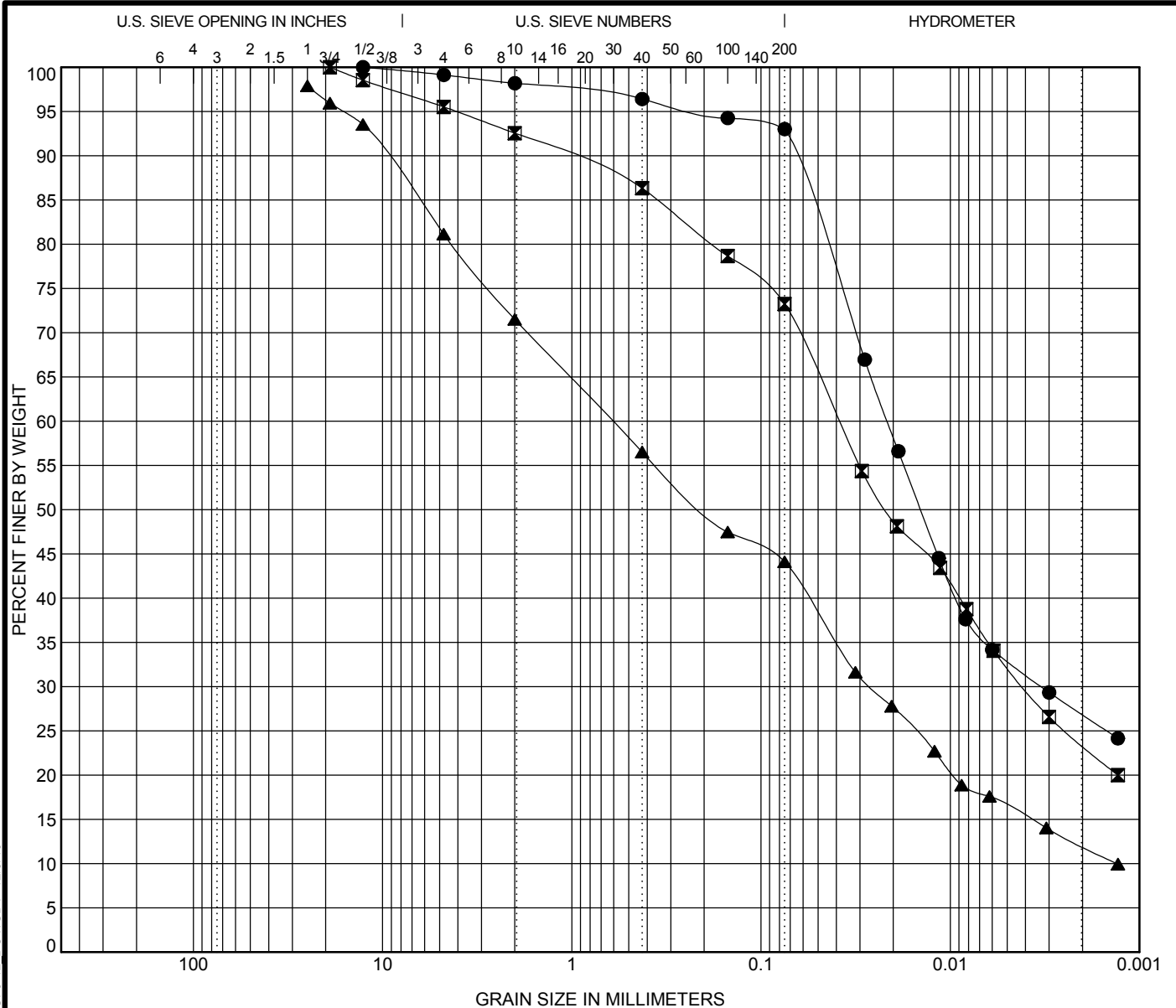

COBBLES	GRAVEL	SAND		SILT	CLAY
		coarse	fine		

Specimen Identification	Classification	LL	PL	PI	Cc	Cu
● 102 2.50	A-7-6 (29) SILTY CLAY LOAM	47.0	16.7	30.3		
☒ 104 2.00	A-6 (7) CLAY LOAM	26.7	12.9	13.8		
▲ 202 0.00	A-6 (3) SANDY LOAM	32.3	17.9	14.4	0.86	463.33

Specimen Identification	D100	D60	D30	D10	%Gravel	%Sand	%Silt	%Clay
● 102 2.50	12.7	0.021	0.003		1.8	5.2	66.2	26.8
☒ 104 2.00	19	0.039	0.004		7.4	19.3	49.9	23.4
▲ 202 0.00	25	0.61	0.026	0.001	26.4	27.4	32.1	12.0



**Illinois Department of Transportation**  
 Division of Highways  
 Illinois Department of Transportation

**IDH GRAIN SIZE DISTRIBUTION**

Route: US 6 & IL 178  
 Section: (31)N,SFY  
 County: LaSalle

# Appendix I

## IDH Textural Classification Chart

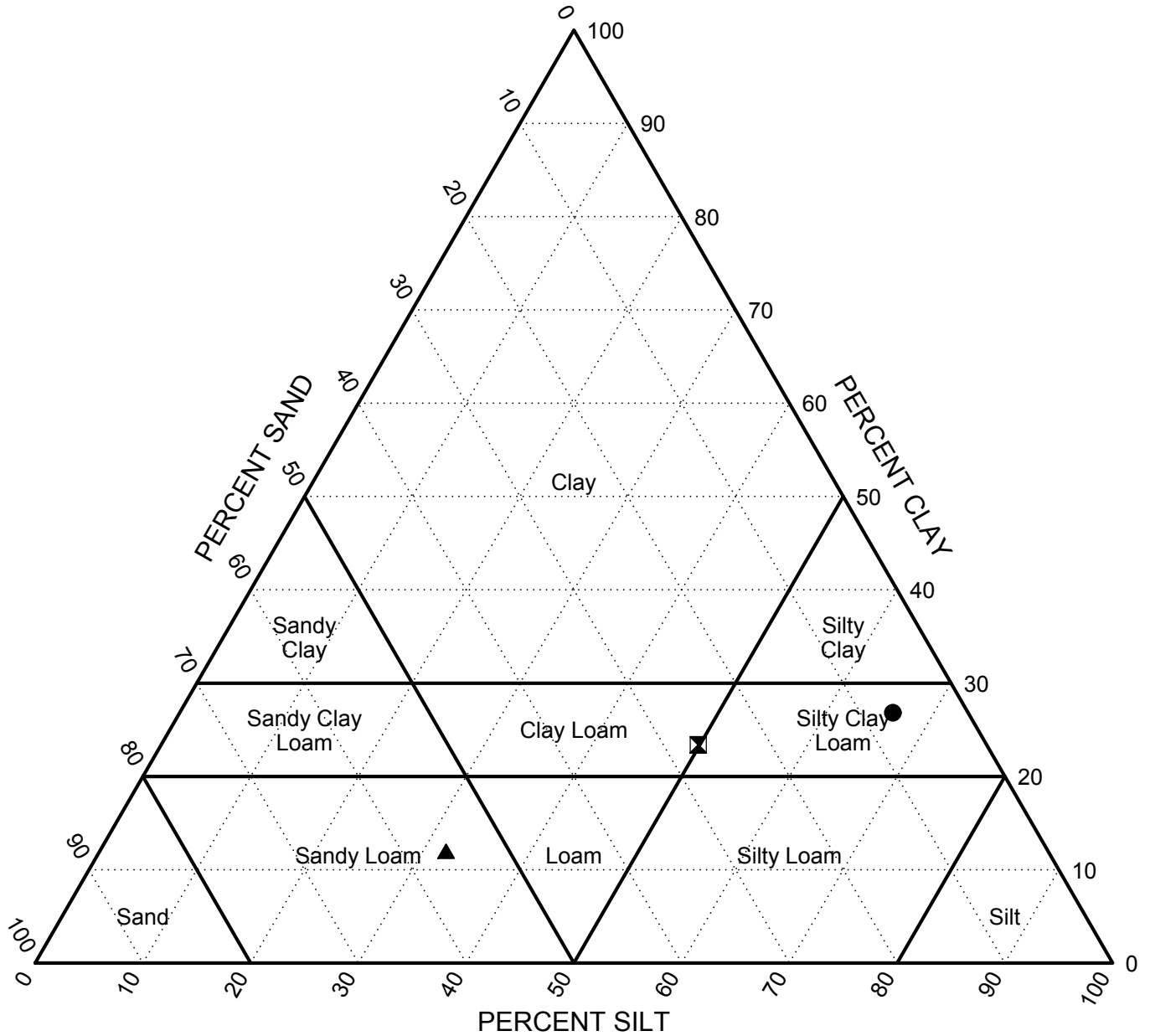

	Borehole	Station	Offset	Depth ( ft)	Classification
●	102	281+83.52	24.66 ft Lt.	2.50	A-7-6 (29) SILTY CLAY LOAM
■	104	286+05.35	39.76 ft Lt.	2.00	A-6 (7) CLAY LOAM
▲	202	94+18.57	24.09 ft Lt.	0.00	A-6 (3) SANDY LOAM



**Illinois Department of Transportation**  
 Division of Highways  
 Illinois Department of Transportation

**IDH Textural Classification Chart**

Route: US 6 & IL 178

Section: (31)N,SFY

County: LaSalle

# Appendix J

## Subgrade Support Rating Chart

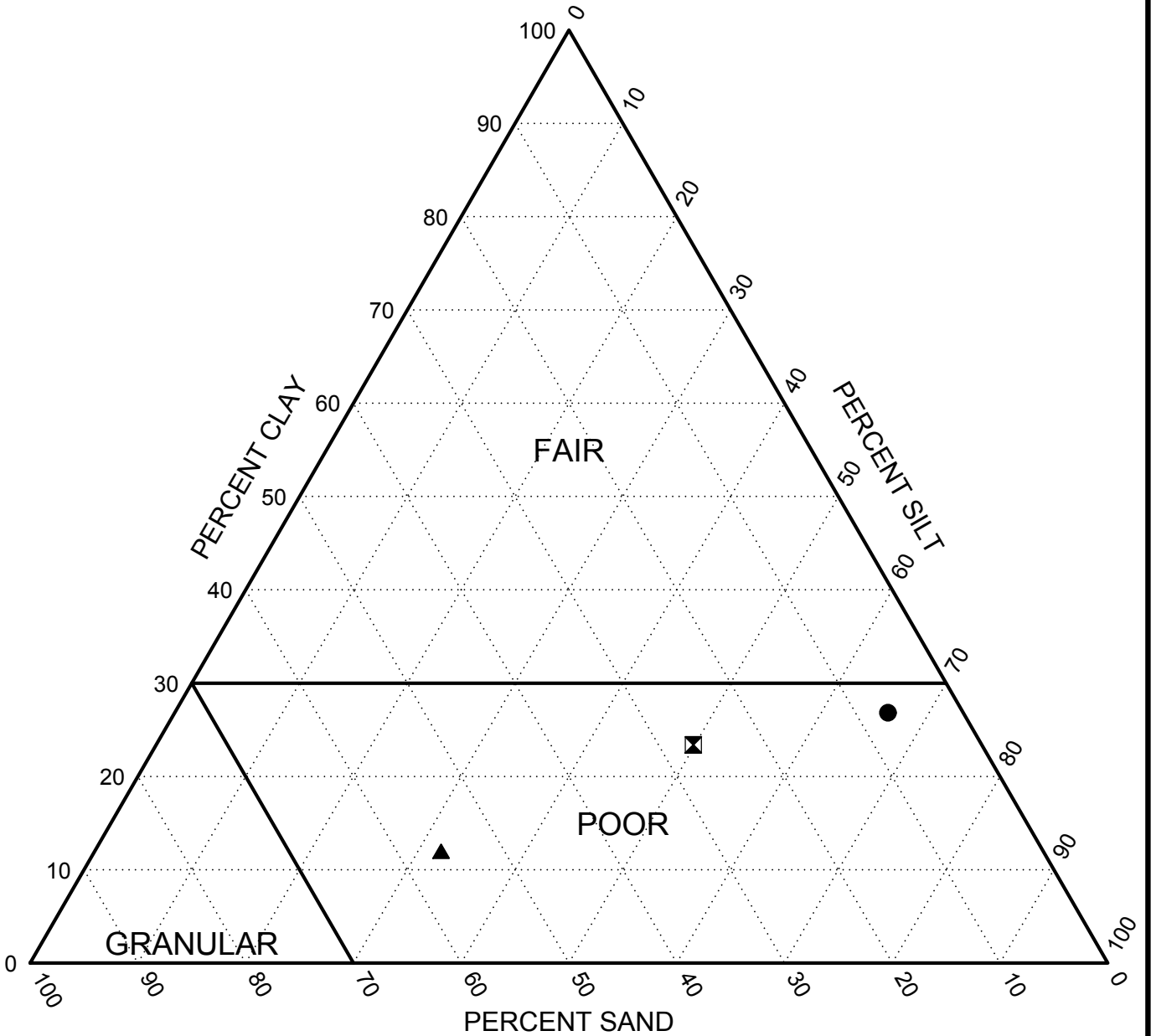

	Borehole	Station	Offset	Depth ( ft)	Classification
●	102	281+83.52	24.66 ft Lt.	2.50	A-7-6 (29) SILTY CLAY LOAM
◻	104	286+05.35	39.76 ft Lt.	2.00	A-6 (7) CLAY LOAM
▲	202	94+18.57	24.09 ft Lt.	0.00	A-6 (3) SANDY LOAM



**Illinois Department of Transportation**  
 Division of Highways  
 Illinois Department of Transportation

**SUBGRADE SUPPORT RATING**

Route: US 6 & IL 178

Section: (31)N,SFY

County: LaSalle



# Appendix K

## Special Provisions

## **Geotechnical Reports**

Revised 12-24-2019

A Roadway Geotechnical Report has been prepared for this project. Copies can be obtained by contacting Jeremy Brown, District Geotechnical Engineer, at 1-815-433-7098 or [Jeremy.Brown@Illinois.gov](mailto:Jeremy.Brown@Illinois.gov).

# Appendix L

Aggregate Subgrade  
Improvement (District 3)  
Special Provision

**3A**

**AGGREGATE SUBGRADE IMPROVEMENT (District 3)**

(Effective April 1, 2012; Revised July 8, 2019)

Add the following Section to the Standard Specifications:

**“SECTION 303. AGGREGATE SUBGRADE IMPROVEMENT**

**303.01 Description.** This work shall consist of constructing an aggregate subgrade improvement.

**303.02 Materials.** Materials shall be according to the following.

Item	Article/Section
(a) Coarse Aggregate .....	1004.07
(b) Reclaimed Asphalt Pavement (RAP) (Notes 1, 2, and 3) .....	1031

Note 1. Crushed RAP, from either full depth or single lift removal, may be mechanically blended with aggregate gradations CS 01 or CS 02 but shall not exceed 40 percent of the total product. The top size of the RAP shall be less than 4 in. (100 mm) and well graded.

Note 2. RAP having 100 percent passing the 1 1/2 in. (37.5 mm) sieve and being well graded, may be used as capping aggregate in the top 3 in. (75 mm) when aggregate gradations CS 01 or CS 02 are used in lower lifts. The RAP shall not be gap graded, single sized, or have a maximum size of less than 3/4 in. (19 mm).

Note 3. The RAP used for aggregate subgrade improvement shall be according to the current Bureau of Materials and Physical Research Policy Memorandum, “Reclaimed Asphalt Pavement (RAP) for Aggregate Applications”.

**303.03 Equipment.** The vibratory machine shall be according to Article 1101.01 or as approved by the Engineer.

**303.04 Soil Preparation.** The stability of the soil shall be according to the Department’s Subgrade Stability Manual for the aggregate thickness specified.

**303.05 Placing Aggregate.** The maximum nominal lift thickness of aggregate gradations CS 01 and CS 02 shall be 24 in. (600 mm).

**303.06 Capping Aggregate.** The top surface of the aggregate subgrade shall consist of a minimum 3 inches (75 mm) of aggregate gradations CA 06 or CA 10.

**303.07 Compaction.** All aggregate lifts shall be compacted to the satisfaction of the Engineer. If the moisture content of the material is such that compaction cannot be obtained, sufficient water shall be added so that satisfactory compaction can be obtained.

**303.08 Finishing and Maintenance of Aggregate Subgrade Improvement.** The aggregate subgrade improvement shall be finished to the lines, grades, and cross

sections shown on the plans, or as directed by the Engineer. The aggregate subgrade improvement shall be maintained in a smooth and compacted condition.

**303.09 Method of Measurement.** This work will be measured for payment according to Article 311.08.

**303.10 Basis of Payment.** This work will be paid for at the contract unit price per square yard (square meter) for AGGREGATE SUBGRADE IMPROVEMENT, of the thickness specified.”

Add the following to Section 1004 of the Standard Specifications:

**“1004.07 Coarse Aggregate for Aggregate Subgrade Improvement.** The aggregate shall be according to Article 1004.01 and the following.

- (a) Description. The coarse aggregate shall be crushed gravel, crushed stone, or crushed concrete.
- (b) Quality. The coarse aggregate shall consist of sound durable particles reasonably free of deleterious materials.
- (c) Gradation.
  - (1) The coarse aggregate gradation for total subgrade thickness less than or equal to 12 inches (300 mm) shall be CS 02.

The coarse aggregate gradation for total subgrade thickness more than 12 inches (300 mm) shall be CS 01 or CS 02.

COARSE AGGREGATE SUBGRADE GRADATIONS					
Grad No.	Sieve Size and Percent Passing				
	8"	6"	4"	2"	#4
CS 01	100	97 ± 3	90 ± 10	45 ± 25	20 ± 20
CS 02		100	80 ± 10	25 ± 15	

COARSE AGGREGATE SUBGRADE GRADATIONS (Metric)					
Grad No.	Sieve Size and Percent Passing				
	200 mm	150 mm	100 mm	50 mm	4.75 mm
CS 01	100	97 ± 3	90 ± 10	45 ± 25	20 ± 20
CS 02		100	80 ± 10	25 ± 15	

- (2) The 3 inch (75 mm) capping aggregate shall be gradation CA 6 or CA 10."