

STATE OF ILLINOIS
DEPARTMENT OF TRANSPORTATION

F.A.P. RTE.	SECTION	COUNTY	TOTAL SHEETS	SHEET NO.
302	(34-3) Q	HANCOCK	27	1
		ILLINOIS	CONTRACT NO. 72L72	

INDEX OF SHEETS

- 1 COVER SHEET
- 2 GENERAL NOTES, OUTLET MARKER DETAIL
- 3 - 4 SUMMARY OF QUANTITIES
- 5 - 10 SCHEDULE OF QUANTITIES
- 11 - 14 TYPICAL SECTIONS
- 15 - 27 PLAN SHEETS

TRAFFIC INFORMATION

2019 ADT IL 110/336 = 4400, MU= 13.07%, SU= 4.66%

PROPOSED
HIGHWAY PLANS

FAP 302 (US 136), FAP 315 (IL 110/IL 336)
SECTION (34-3) Q
PROJECT: NHPP-HBI8(416)
CAPE SEAL FOG SEAL AND MICROSURFACING
HANCOCK COUNTY

STANDARDS

- 000001-8 701411-09
- 001006 701426-09
- 701101-05 701451-05
- 701106-02
- 667001-01 701901-08
- 701201-05 780001-05
- 701400-10 781001-04
- 701406-12

BEGIN PROJECT US 136
STA 113+81.00

BRIDGE OMISSION
SN 034-0503
STA 98+68.75 TO 101+31.25

BEGIN PROJECT
STA 687+60.5

C-96-061-20

END PROJECT
STA 1001+00

BRIDGE OMISSION
SN 034-0506
SN 034-0507
STA 972+79 TO 973+77

END PROJECT US 136
STA 95+20.00

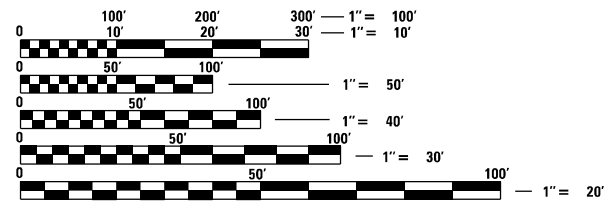

FULL SIZE PLANS HAVE BEEN PREPARED USING STANDARD ENGINEERING SCALES, REDUCED SIZED PLANS WILL NOT CONFORM TO STANDARD SCALES. IN MAKING MEASUREMENTS ON REDUCED PLANS, THE ABOVE SCALES MAY BE USED.

J.U.L.I.E.
JOINT UTILITY LOCATION INFORMATION FOR EXCAVATION
1-800-892-0123
OR 811

PROJECT ENGINEER: JAY EDWARDS (217) 785-0597
PROJECT MANAGER: FILIBERTO SOTELO (217) 524-782-1378
JONATHAN COX (217) 782-1378

CONTRACT NO. 72L72

GROSS LENGTH = 31,339.50 FT. = 5.94 MILES
NET LENGTH = 31,241.50 FT. = 5.92 MILES

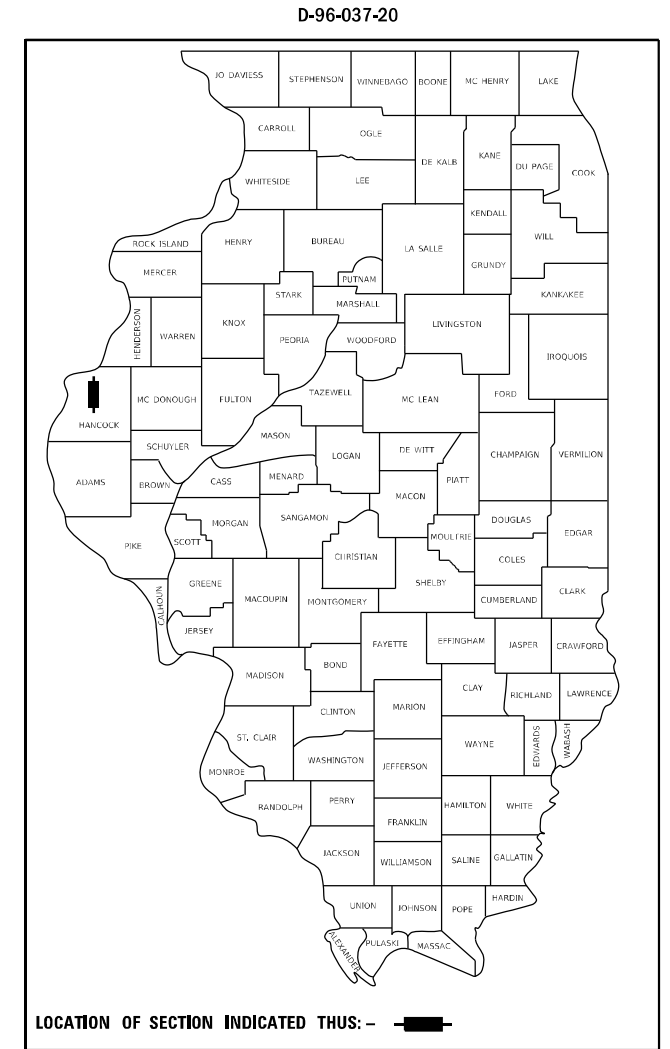

LOCATION OF SECTION INDICATED THUS: - [black rectangle] -

STATE OF ILLINOIS
DEPARTMENT OF TRANSPORTATION

SUBMITTED December 11, 2020

Jay P. Myers
REGIONAL ENGINEER

January 29, 2021
Scott A. Etk
ENGINEER OF DESIGN AND ENVIRONMENT

January 29, 2021
James J. Gu
DIRECTOR OF HIGHWAYS PROJECT IMPLEMENTATION

PRINTED BY THE AUTHORITY
OF THE STATE OF ILLINOIS

GENERAL NOTES:

1. THE CONTRACTOR SHALL NOTIFY THE DISTRICT 6 BUREAU OF OPERATIONS AT (217) 785-5306 THREE WEEKS PRIOR TO IMPLEMENTING ANY TRAFFIC CONTROL.
2. AS PER THE BDE SPECIAL PROVISION FOR MICRO-SURFACING AND SLURRY SEALING, RAISED REFLECTIVE PAVEMENT MARKERS SHALL BE REMOVED ACCORDING TO ARTICLE 783.03(b) AND HOLES FILLED WITH HMA, RUT FILLING MIX, OR OTHER MATERIAL APPROVED BY THE ENGINEER. THIS SHALL NOT BE PAID FOR SEPARATELY, BUT CONSIDERED AS PART OF THE WORK FOR CAPE SEAL.
3. WHERE SECTION OR SUBSECTION MONUMENTS ARE ENCOUNTERED, THE ENGINEER SHALL BE NOTIFIED BEFORE SUCH MONUMENTS ARE REMOVED. THE CONTRACTOR SHALL PROTECT AND CAREFULLY PRESERVE ALL MONUMENTS UNTIL AN AUTHORIZED SURVEYOR OR AGENT HAS WITNESSED OR OTHERWISE REFERENCED THEIR LOCATION. THE CONTRACTOR SHALL BE RESPONSIBLE FOR HAVING AN AUTHORIZED SURVEYOR RE-ESTABLISH ANY SECTION OR SUBSECTION MONUMENTS DESTROYED BY HIS OPERATIONS.

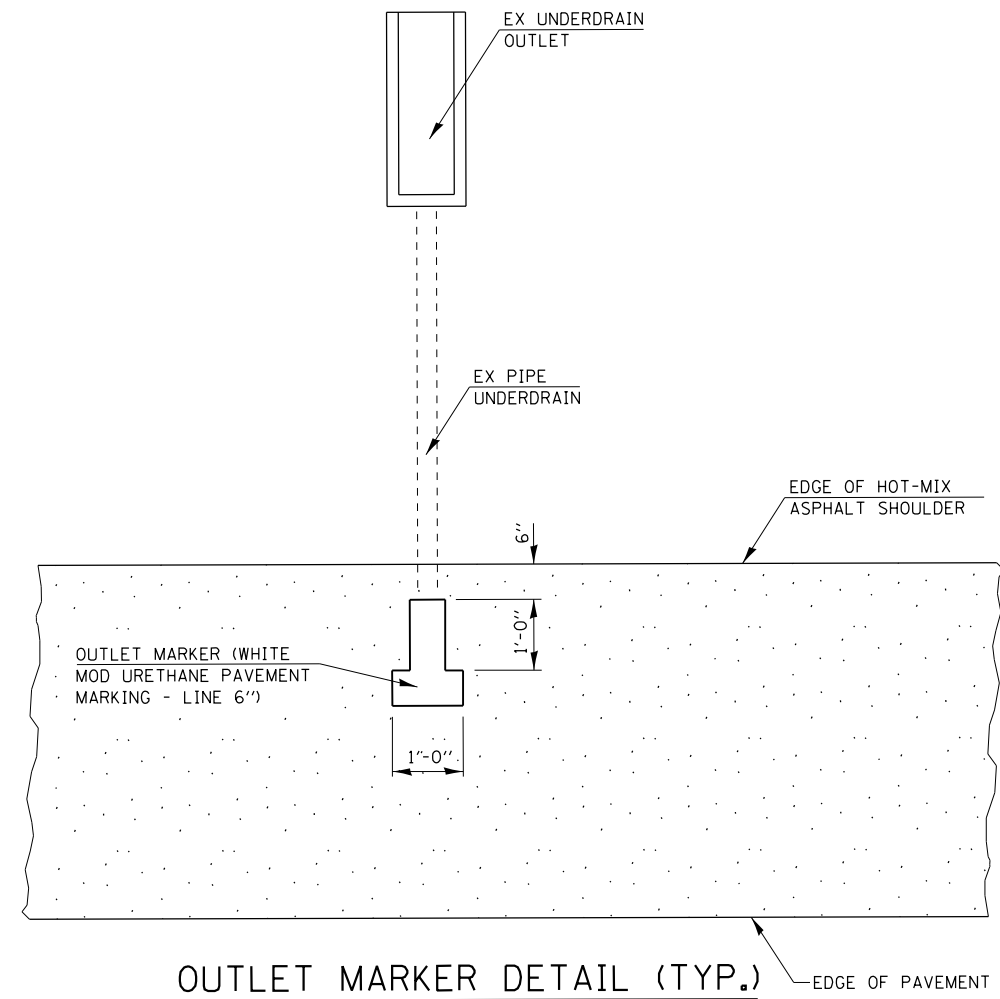

COMMITMENTS

NONE

RATES OF APPLICATION USED TO CALCULATE PLAN QUANTITIES

BITUMINOUS MATERIALS (FOG SEAL)	0.08 POUNDS/ SQ FT, SHOULDER
	0.05 POUNDS/ SQ FT, MAIN LINE

**STATE OF ILLINOIS
DEPARTMENT OF TRANSPORTATION
DIVISION OF HIGHWAYS
DISTRICT 6**

EXAMINED	December 4	20	20	
	<i>[Signature]</i>			ENGINEER OF OPERATIONS
EXAMINED	December 3	20	20	
	<i>[Signature]</i>			ENGINEER OF PROJECT IMPLEMENTATION
EXAMINED	December 5	20	20	
	<i>[Signature]</i>			ENGINEER OF PROGRAM DEVELOPMENT

MODEL: Default
 FILE: \\nrcs-pub\pub\harcourt\dot\Documents\DOT_Offices\District_6\Projects\0672172\CADD\DATA\CAD\Sheets\0672172-shc-999999.dgn

	USER NAME = coxjw	DESIGNED -	REVISED -	STATE OF ILLINOIS DEPARTMENT OF TRANSPORTATION	GENERAL NOTES	F.A.P. RTE.	SECTION	COUNTY	TOTAL SHEETS	SHEET NO.
		DRAWN -	REVISED -			302	(34-3) Q	HANCOCK	27	2
	PLOT SCALE = 20.0000 ' / in.	CHECKED -	REVISED -		SCALE: NTS	SHEET 1 OF 1 SHEETS		ILLINOIS	CONTRACT NO. 72L72	
	PLOT DATE = 12/11/2020	DATE -	REVISED -		STA. 687+60.5	TO STA. 1001+00		FED. AID PROJECT		

6-01260-0000

80% FEDERAL
20% STATE

ROADWAY
0005
RURAL

CODE NO.	ITEM	UNIT	TOTAL QUANTITY	
40400118	MICRO-SURFACING, SINGLE PASS	SQ YD	6925	6925
40500061	CAPE SEAL	SQ YD	206983	206983
40600290	BITUMINOUS MATERIALS (TACK COAT)	POUND	3116	3116
67000400	ENGINEER'S FIELD OFFICE, TYPE A	CAL MO	12	12
67100100	MOBILIZATION	L SUM	1	1
70100420	TRAFFIC CONTROL AND PROTECTION, STANDARD 701411	EACH	4	4
70100450	TRAFFIC CONTROL AND PROTECTION, STANDARD 701201	L SUM	1	1
70100700	TRAFFIC CONTROL AND PROTECTION, STANDARD 701406	L SUM	1	1
70100820	TRAFFIC CONTROL AND PROTECTION, STANDARD 701451	L SUM	1	1
70107025	CHANGEABLE MESSAGE SIGN	CAL DA	100	100
70300100	SHORT TERM PAVEMENT MARKING	FOOT	30393	30393
70300150	SHORT TERM PAVEMENT MARKING REMOVAL	SQ FT	1948	1948
* 78009000	MODIFIED URETHANE PAVEMENT MARKING - LETTERS AND SYMBOLS	SQ FT	1607	1607
* 78009005	MODIFIED URETHANE PAVEMENT MARKING - LINE 5"	FOOT	149290	149290

* SPECIALTY ITEM

MODEL: Default
FILE: h:\mhc\p\suplanroom.dta\illinois.gov\PWIDOT\Documents\DOT_Offices\Director\Projects\0672172\CADDData\CAD\Sheets\0672172-rh-500.dgn

USER NAME = coxjw	DESIGNED -	REVISED -
	DRAWN -	REVISED -
PLOT SCALE = 100.0000' / in.	CHECKED -	REVISED -
PLOT DATE = 12/11/2020	DATE -	REVISED -

**STATE OF ILLINOIS
DEPARTMENT OF TRANSPORTATION**

SUMMARY OF QUANTITIES

SCALE: SHEET 1 OF 2 SHEETS STA. TO STA.

F.A.P RTE.	SECTION	COUNTY	TOTAL SHEETS	SHEET NO.
302	(34-3) Q	HANCOCK	27	3
			CONTRACT NO. 72L72	
			ILLINOIS FED. AID PROJECT	

MEDIAN AND SIDE ROAD MICRO-SURFACING SCHEDULE				
BEGIN STATION	END STATION	AREA (SQ FT)	40400118	40600290
			MICRO-SURFACING, SINGLE PASS	BITUMINOUS MATERIALS (TACK COAT)
			SQ YD	POUND
693+75	695+14	8734	970	437
720+70	722+29	2172	241	109
747+85	749+03	8746	972	437
774+34	775+88	5341	593	267
801+83	803+38	10465	1163	523
887+59	889+00	7679	853	384
916+85	918+45	2025	225	101
942+17	943+72	7645	849	382
978+74	980+38	2317	257	116
994+62	996+38	7199	800	360
TOTAL			6925	3116

RAISED REFLECTIVE PAVEMENT MARKER					
BEGIN STATION	END STATION	LENGTH	NO. OF REFLECTORS	78100100	78300200
				RAISED REFLECTIVE PAVEMENT MARKER	RAISED REFLECTIVE PAVEMENT MARKER REMOVAL
				EACH	EACH
687+60.5	691+50.00	389.50	X2	10	10
691+50.00	694+00.00	250.00	X4	13	13
694+00.00	695+00.00	100.00	x2	3	3
695+00.00	697+50.00	250.00	x4	13	13
697+50.00	745+50.00	4800.00	x2	120	120
745+50.00	748+00.00	250.00	x4	13	13
748+00.00	749+00.00	100.00	x2	3	3
749+00.00	751+50.00	250.00	x4	13	13
751+50.00	772+00.00	2050.00	x2	51	51
772+00.00	774+50.00	250.00	x4	13	13
774+50.00	775+50.00	100.00	x2	3	3
775+50.00	778+00.00	250.00	x3	9	9
778+00.00	798+50.00	2050.00	x2	51	51
798+50.00	801+50.00	300.00	x4	15	15
801+50.00	803+00.00	150.00	x2	4	4
803+00.00	805+50.00	250.00	x4	13	13
805+50.00	807+00.00	150.00	x3	6	6
807+00.00	833+00.00	2600.00	x2	65	65
833+00.00	837+50.00	450.00	x3	17	17
837+50.00	864+50.00	2700.00	x2	68	68
864+50.00	868+50.00	400.00	x3	15	15
868+50.00	972+25.00	10375.00	x2	259	259
BRIDGE OMISSION					
974+00.00	1001+00.00	2700.00	x2	68	68
RAMP D					
0+00.00	3+00.00	300.00	X1	4	4
3+00.00	7+00.00	400.00	x2	10	10
7+00.00	13+00.00	600.00	X1	8	8
RAMP B					
0+00.00	3+00.00	300.00	X1	4	4
3+00.00	7+00.00	400.00	x2	10	10
7+00.00	14+00.00	700.00	X1	9	9
TOTAL				883	883

MODEL: Default
 FILE: \\nlsr01\pub\lansom.dwg
 PROJECT: \\nlsr01\pub\lansom.dwg
 PLOT DATE: 12/11/2020

USER NAME = coxjw	DESIGNED -	REVISED -
	DRAWN -	REVISED -
PLOT SCALE = 100.0000' / in.	CHECKED -	REVISED -
PLOT DATE = 12/11/2020	DATE -	REVISED -

STATE OF ILLINOIS
DEPARTMENT OF TRANSPORTATION

SCHEDULE SCALE: SHEET 1 OF 6 SHEETS STA. TO STA.		F.A.P. RTE.	SECTION	COUNTY	TOTAL SHEETS	SHEET NO.
		302	(34-3) R5	HANCOCK	27	5

ILLINOIS FED. AID PROJECT CONTRACT NO. 72L72	
---	--

CAPE SEAL SCHEDULE

DIRECTION	WIDTH (FT)	BEGIN STATION	END STATION	LENGTH (FT)	DESCRIPTION	40500061	Z0004542	X0300010
						CAPE SEAL	HMA REM (SPECIAL)	BIT MAT (FOG SEAL)
						SQ YD	SQ YD	POUNDS
IL 110/336	24	687+60.5	972+68	28,507.50	NB MAINLINE	76020	76020	34209
		687+60.5	972+25	28,464.50	SB MAINLINE	75905	75905	34157
		974+35	1001+00	2,665.00	NB MAINLINE	7107	7107	3198
		973+93	1001+00	2,707.00	SB MAINLINE	7219	7219	3248
NB TURN LANES	VARIES	689+33	695+14	581	RIGHT TURN LANE	617	617	278
		689+53	695+44	591	LEFT TURN LANE	548	548	246
		716+40	722+29	589	LEFT TURN LANE	653	653	294
		743+27	749+04	577	RIGHT TURN LANE	615	615	277
		743+35	749+25	590	LEFT TURN LANE	607	607	273
		769+93	775+69	576	RIGHT TURN LANE	628	628	282
		769+98	775+88	590	LEFT TURN LANE	609	609	274
		795+69	803+38	769	LEFT TURN LANE	831	831	374
		797+42	803+18	576	RIGHT TURN LANE	605	605	272
		883+12	889+00	588	LEFT TURN LANE	643	643	290
		883+29	888+85	556	RIGHT TURN LANE	553	553	249
		912+56	918+45	589	LEFT TURN LANE	767	767	345
		937+41	943+72	631	LEFT TURN LANE	682	682	307
		937+64	943+54	590	RIGHT TURN LANE	608	608	274
974+87	980+38	551	LEFT TURN LANE	545	545	245		
990+65	995+95	530	RIGHT TURN LANE	510	510	229		
990+70	996+20	550	LEFT TURN LANE	545	545	245		
SB TURN LANES	VARIES	693+75	699+63	588	LEFT TURN LANE	590	590	265
		694+05	699+85	580	RIGHT TURN LANE	617	617	278
		720+71	726+61	590	LEFT TURN LANE	598	598	269
		747+65	753+55	590	LEFT TURN LANE	600	600	270
		747+85	753+63	578	RIGHT TURN LANE	623	623	280
		774+34	780+16	582	LEFT TURN LANE	613	613	276
		801+79	807+69	590	LEFT TURN LANE	612	612	275
		801+83	809+83	800	RIGHT TURN LANE	864	864	389
		887+40	893+30	590	LEFT TURN LANE	616	616	277
		887+59	893+36	577	RIGHT TURN LANE	591	591	266
		916+85	922+77	592	LEFT TURN LANE	540	540	243
		942+07	947+68	561	RIGHT TURN LANE	547	547	246
942+17	947+71	554	LEFT TURN LANE	608	608	273		
978+74	984+15	541	LEFT TURN LANE	736	736	331		
994+45	1000+00	555	LEFT TURN LANE	613	613	276		
994+80	1000+00	520	RIGHT TURN LANE	537	537	242		
RAMPS	VARIES	+	22+88	2,288	RAMP A	3820	3820	1719
		+	19+00	1,900	RAMP B	3346	3346	1506
		+	25+29	2,529	RAMP C	4296	4296	1933
		+	24+00	2,400	RAMP D	4198	4198	1889
US 136	VARIES	95+20	98+69	349	NORTH OF OVERPASS	1627	1627	732
		101+31	113+81	1,250	SOUTH OF OVERPASS	2976	2976	1339
TOTAL						206983	206983	93142

MODEL: Default
 FILE: Model_CapeSeal.dwg
 PROJECT: ILLINOIS STATE ROADWAY PROJECTS
 DRAWING: ILLINOIS STATE ROADWAY PROJECTS
 SHEET: ILLINOIS STATE ROADWAY PROJECTS
 DATE: 12/11/2020

USER NAME = coxjw	DESIGNED -	REVISED -
	DRAWN -	REVISED -
PLOT SCALE = 100.0000' / in.	CHECKED -	REVISED -
PLOT DATE = 12/11/2020	DATE -	REVISED -

**STATE OF ILLINOIS
DEPARTMENT OF TRANSPORTATION**

SCHEDULE	
SCALE:	SHEET 2 OF 6 SHEETS STA. TO STA.

F.A.P. RTE.	SECTION	COUNTY	TOTAL SHEETS	SHEET NO.
302	(34-3) R5	HANCOCK	27	6
CONTRACT NO. 72L72			ILLINOIS FED. AID PROJECT	

PAVEMENT MARKING SCHEDULE

DIRECTION	BEGIN STATION	END STATION	78009000	78009005	78009006	78009008	78009012	78009024
			MODIFIED URETHANE PAVEMENT MARKING- LETTERS AND SYMBOLS	MODIFIED URETHANE PAVEMENT MARKING- LINE 5"	MODIFIED URETHANE PAVEMENT MARKING- LINE 6"	MODIFIED URETHANE PAVEMENT MARKING- LINE 8"	MODIFIED URETHANE PAVEMENT MARKING- LINE 12"	MODIFIED URETHANE PAVEMENT MARKING- LINE 24"
NB CENTERLINE	687+60.5	972+68		7127				
	974+35	1001+00		666				
SB CENTERLINE	687+60.5	972+25		7116				
	973+93	1001+00		677				
NB	687+60.5	689+33		345				
	689+33	695+44	116	1207	474	214	81	20
	695+44	743+27		9566				
	743+27	749+25	116	1236	476	196	71	20
	749+25	769+93		4136				
	769+93	775+88	116	1232	512	93	45	20
	775+88	795+69		3962				
	795+69	803+18	116	1537	560	79	27	20
	803+18	883+12		13536				
	883+12	889+00	116	1139	475	149	49	20
	889+00	937+41		9682				
	937+41	943+72	85	1285	528	180	56	20
	943+72	972+68		5792				
	972+68	990+70		3269				
	990+70	1001+00	85	2143	489	136	33	20
	SB	687+60.5	693+75		615			
693+75		699+85	116	1239	477	203	80	20
699+85		747+65		4780				
747+65		753+63	116	1215	474	196	77	20
753+63		774+34		2071				
774+34		780+16	69	1115	248	86	18	20
780+16		801+83		4334				
801+83		809+83	132	1702	609	246	123	20
809+83		887+59		14371				
887+59		893+36	132	1212	480	183	62	20
893+36		942+07		9741				
942+07		947+69	54	1108	489	104	23	20
947+69		972+25		4913				
972+25		973+93		4104				
973+93	994+45	85	1374	497	65	14	20	
994+45	1001+00							
RAMP A	+	22+88		3640				
RAMP B	+	19+00	31	3367		196	65	40
RAMP C	+	25+29		4235				
RAMP D	+	24+00	31	4526		118	46	40
US 136	95+20	98+69	47	1028	185			
	101+31	113+81	47	2949	185			
TOTAL			1607	149290	7156	2444	870	359

MODEL: Default
FILE: Model_C:\pub\lhamrson.dwg
PROJECT: I:\Projects\067272\CADD\Drawings\DOT Office\067272\067272-01-sht-schedule.dwg

USER NAME = coxjw	DESIGNED -	REVISED -
	DRAWN -	REVISED -
PLOT SCALE = 100.0000' / in.	CHECKED -	REVISED -
PLOT DATE = 12/11/2020	DATE -	REVISED -

**STATE OF ILLINOIS
DEPARTMENT OF TRANSPORTATION**

SCHEDULE		SCALE:	SHEET 3	OF 6	SHEETS	STA.	TO STA.

F.A.P. RTE.	SECTION	COUNTY	TOTAL SHEETS	SHEET NO.
302	(34-3) R5	HANCOCK	27	7
CONTRACT NO. 72L72				
ILLINOIS FED. AID PROJECT				

SHOULDERS BITUMINOUS FOG SEAL SCHEDULE							
DIRECTION	BEGIN STATION	END STATION	INSIDE / OUTSIDE	LENGTH (FT)	WIDTH (FT)	AREA (SQ FT)	X0300010
							BIT MAT (FOG SEAL) POUND
SB	687+61	694+05	OUTSIDE	645	10	6445	516
	687+61	693+75	INSIDE	615	6	3687	295
	693+75	699+63	INSIDE	588	VARIES	2163	173
	694+05	699+85	OUTSIDE	580	VARIES	3104	248
	699+63	720+71	INSIDE	2108	4	8432	675
	699+85	747+85	OUTSIDE	4800	10	48000	3840
	720+71	726+61	INSIDE	590	VARIES	2187	175
	726+61	747+65	INSIDE	2104	4	8416	673
	747+65	753+55	INSIDE	590	VARIES	2183	175
	747+85	753+63	OUTSIDE	578	VARIES	3100	248
	753+55	774+34	INSIDE	2079	4	8316	665
	753+63	801+83	OUTSIDE	4820	10	48200	3856
	774+34	780+16	INSIDE	582	VARIES	2136	171
	780+16	801+79	INSIDE	2163	4	8652	692
	801+79	807+69	INSIDE	590	VARIES	2149	172
	801+83	809+83	OUTSIDE	800	VARIES	4195	336
	807+69	887+40	INSIDE	7971	4	31884	2551
	809+83	831+69	OUTSIDE	2186	10	21860	1749
	843+50	865+03	OUTSIDE	2153	10	21530	1722
	871+62	887+59	OUTSIDE	1597	10	15970	1278
	887+40	893+30	INSIDE	590	VARIES	2174	174
	887+59	893+36	OUTSIDE	577	VARIES	2927	234
	893+30	916+85	INSIDE	2355	4	9420	754
	893+36	942+07	OUTSIDE	4871	10	48710	3897
	916+85	922+77	INSIDE	592	VARIES	2132	171
	922+17	942+17	INSIDE	2000	4	8000	640
	942+07	947+68	OUTSIDE	561	VARIES	3934	315
	942+17	947+71	INSIDE	554	VARIES	2662	213
	947+68	972+25	OUTSIDE	2457	10	24570	1966
	947+71	972+25	INSIDE	2454	4	9816	785
	973+93	975+00	OUTSIDE	107	10	1070	86
	973+93	978+74	INSIDE	481	4	1924	154
	975+00	994+45	OUTSIDE	1945	10	19450	1556
	978+74	984+16	INSIDE	542	VARIES	1982	159
	984+16	994+45	INSIDE	1029	4	4116	329
	994+45	1001+00	INSIDE	655	VARIES	1037	83
	994+45	1001+00	OUTSIDE	655	VARIES	1314	105
RAMP A	+	22+88	OUTSIDE	2288	8	18307	1465
	10+85	22+88	INSIDE	1203	6	7220	578
RAMP B	+	19+00	OUTSIDE	1900	8	15200	1216
	6+65	19+00	INSIDE	1235	6	7410	593
RAMP C	+	25+29	OUTSIDE	2529	8	20234	1619
	12+80	25+29	INSIDE	1249	6	7496	600
RAMP D	+	24+00	OUTSIDE	2400	8	19200	1536
	6+60	24+00	INSIDE	1740	6	10440	835
US 136	96+22	98+69	OUTSIDE	247	10	4940	395
	101+31	103+83	OUTSIDE	252	10	5040	403
	105+00	113+81	OUTSIDE	881	10	17620	1410
SUB TOTAL							42476
TOTAL							74474

INLETS/OUTLETS SCHEDULE			
STATION	X0320157	X0322279	Z0010615
	LEANING UNDERDRAIN OUTLET	OUTLET MARKERS	LEANING EXISTING INLET
	EACH	EACH	EACH
690+50	4	4	
695+43	4	4	1
700+80	4	4	
702+25			1
706+15	4	4	
711+50	4	4	
713+00			1
717+00	4	4	
722+30	4	4	1
727+50	4	4	
730+50			1
732+70	4	4	
737+90	4	4	
747+65	4	4	1
753+00	4	4	
758+00	4	4	1
762+00	4	4	
766+02	4	4	1
771+00	4	4	
776+00	4	4	1
779+25	4	4	
786+80	4	4	
791+00	4	4	
795+50	4	4	
799+00	4	4	
803+38	4	4	1
813+00	4	4	
818+50	4	4	
823+70	4	4	2
828+30	4	4	
832+90	4	4	
835+00			1
837+50	3	3	1
843+00	4	4	1
848+30	4	4	1
852+50	4	4	
860+50	4	4	
862+00	1	1	
864+50	3	3	
867+00			1
868+50			1
873+00	2	2	
873+50	2	2	
877+50	4	4	1
882+50	4	4	
887+40	4	4	1
892+50	4	4	
896+88	4	4	2
901+00	4	4	
SUB TOTAL	163	163	22

MODEL: Default
 FILE: h:\mhc\p\pub\haronom.dwg
 PROJECT: I:\projects\0672172\CADD\DATA\CAD\sheet\0672172-sh-sched.tbl.dgn

USER NAME = coxjw	DESIGNED -	REVISED -
	DRAWN -	REVISED -
PLOT SCALE = 100.0000' / in.	CHECKED -	REVISED -
PLOT DATE = 12/11/2020	DATE -	REVISED -

STATE OF ILLINOIS
DEPARTMENT OF TRANSPORTATION

SCHEDULE			
SCALE:	SHEET 5	OF 6 SHEETS	STA. TO STA.

F.A.P. RTE.	SECTION	COUNTY	TOTAL SHEETS	SHEET NO.
302	(34-3) R5	HANCOCK	27	9
CONTRACT NO. 72L72				
ILLINOIS FED. AID PROJECT				

INLETS/OUTLETS SCHEDULE			
STATION	X0320157	X0322279	Z0010615
	LEANING UNDERDRAIN OUTLET	OUTLET MARKERS	LEANING EXISTING INLET
	EACH	EACH	EACH
905+19	4	4	2
909+50	2	2	
912+00	2	2	1
914+00	4	4	
916+80			1
918+45	4	4	1
926+50	2	2	
927+00	2	2	
930+50	2	2	
934+25	2	2	1
936+00	2	2	
938+50	2	2	
941+95	4	4	1
943+65	4	4	
946+00	4	4	
948+50	4	4	
949+50			1
953+50	4	4	
956+50	4	4	
959+25	4	4	
960+50			1
964+50	4	4	
970+30	4	4	
972+00			1
974+55	4	4	1
976+25	4	4	
980+90	4	4	1
984+10			1
985+25	4	4	
989+37			1
990+00	4	4	
992+40	4	4	
996+30	2	2	
998+35	4	4	
SUB TOTAL	94	94	14

RAMP INLETS/OUTLETS SCHEDULE			
STATION	X0320157	X0322279	Z0010615
	LEANING UNDERDRAIN OUTLET	OUTLET MARKERS	LEANING EXISTING INLET
	EACH	EACH	EACH
RAMP A			
6+00	2	2	
9+50	1	1	
11+00	1	1	
16+00	1	1	
21+00	1	1	
RAMP B			
3+60	1	1	
4+68			1
8+60	1	1	
9+68	1	1	
13+40	1	1	
13+64	1	1	
RAMP C			
6+20	2	2	
11+20	2	2	
19+50	1	1	
24+00	1	1	
RAMP D			
3+20	1	1	
7+28			1
11+00	1	1	1
14+90	2	2	
18+80	2	2	
SUB TOTAL	23	23	3
TOTAL	280	280	39

SURVEY MARKERS		
STATION	OFFSET	Z0049799
		Protecting or Resetting Survey Markers
		EACH
694+48.96	121.64 RT	1
694+68.93	161.45 LT	1
721+51.99	59.76 LT	1
748+39.38	105.42 LT	1
775+32.91	65.93 LT	1
802+26.98	117.54 RT	1
887+97.92	113.52 RT	1
942+48.69	66.96 LT	1
969+10.11	71.99 LT	1
995+72.55	29.73 RT	1
TOTAL		10

MODEL: Default
 FILE: \\hpc\pub\hpcroom\dat\illinois\gov\PWIDOT\Documents\DOT_Offices\Illin\Tct_6\Projects\0672172\CaddData\CAD\Sheets\0672172-sh-sched.tbl.dgn

USER NAME = coxjw	DESIGNED -	REVISED -
	DRAWN -	REVISED -
PLOT SCALE = 100.0000 ' / in.	CHECKED -	REVISED -
PLOT DATE = 12/11/2020	DATE -	REVISED -

STATE OF ILLINOIS
DEPARTMENT OF TRANSPORTATION

SCHEDULE SCALE: SHEET 6 OF 6 SHEETS STA. TO STA.		F.A.P. RTE.	SECTION	COUNTY	TOTAL SHEETS	SHEET NO.
		302	(34-3) R5	HANCOCK	27	10

ILLINOIS FED. AID PROJECT		CONTRACT NO. 72L72
---------------------------	--	--------------------

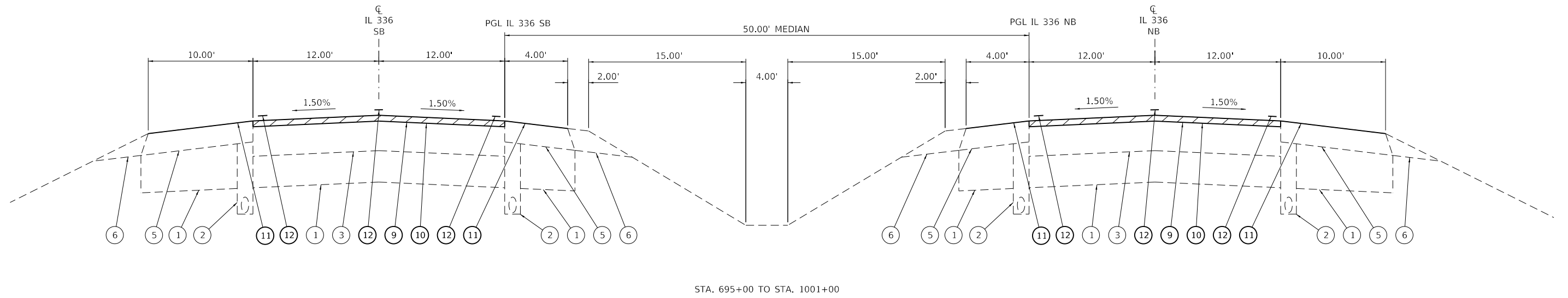
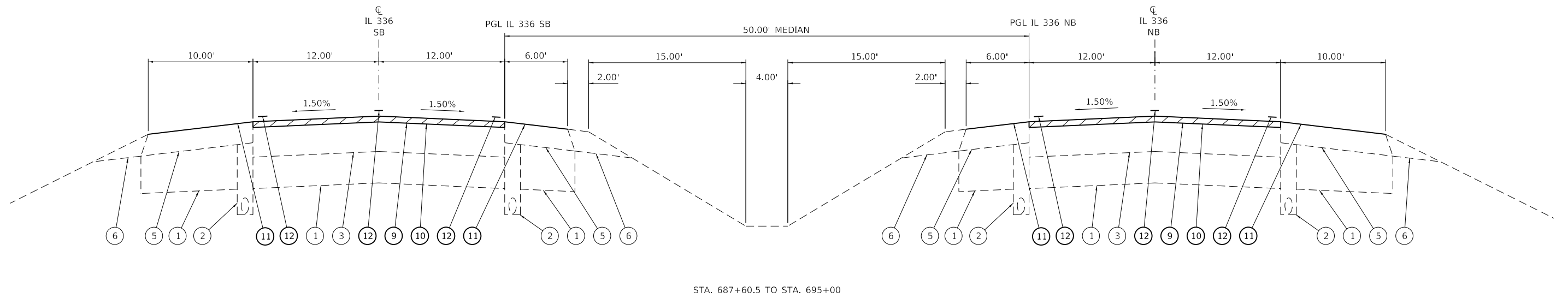

- ① EXIST. SUBBASE GRANULAR MATERIAL, 12"
- ② EXIST. PIPE UNDERDRAINS 4"
- ③ EXIST. FULL-DEPTH HMA PAVEMENT, 13 1/2"
- ④ EXIST. FULL-DEPTH HMA PAVEMENT, 11 1/2"
- ⑤ EXIST. HMA SHOULDERS, 8"
- ⑥ EXIST. AGGREGATE SHOULDERS
- ⑦ EXIST. COMBINATION CONCRETE CURB AND GUTTER TYPE M-4.06
- ⑧ EXIST. SOLID PCC MEDIAN
- ⑨ PROPOSED HOT-MIX ASPHALT REMOVAL (SPECIAL), 1/2"
- ⑩ PROPOSED CAPE SEAL
- ⑪ PROPOSED BITUMINOUS MATERIALS (FOG SEAL)
- ⑫ MODIFIED URETHANE PAVEMENT MARKING - LINE 5"

NOTES:
 1) HMA SURFACE REMOVAL (SPECIAL) SHALL BE DONE BY HOLDING A CONSTANT DEPTH ACROSS THE LANE OF PAVEMENT.

MODEL: Default
 FILE: Model_Cad_Plan_Planroom.dwg
 PROJECT: 067272_CADDATA\CAD\Sheets\067272-RT-1111.dwg

USER NAME = c0xjw	DESIGNED -	REVISED -
PLOT SCALE = 100.0000' / in.	DRAWN -	REVISOR -
PLOT DATE = 12/11/2020	CHECKED -	REVISOR -
	DATE -	REVISOR -

**STATE OF ILLINOIS
 DEPARTMENT OF TRANSPORTATION**

TYPICAL SECTIONS			
SCALE: NTS	SHEET 1	OF 4 SHEETS	STA. 687+60.5 TO STA. 1001+00

F.A.P. RTE.	SECTION	COUNTY	TOTAL SHEETS	SHEET NO.
302	(34-3) Q	HANCOCK	27	11
CONTRACT NO. 72L72				
ILLINOIS FED. AID PROJECT				

LEGEND

- (A) - EXISTING LIME MODIFIED SOIL - 12"
- (B) - EXISTING BITUMINOUS CONCRETE PAVEMENT (FULL DEPTH) SUPERPAVE, 1 3/4 INCH; INCLUDES BITUMINOUS CONCRETE SURFACE COURSE, SUPERPAVE, MIX. "C", N50, 2 INCH, AND BITUMINOUS CONCRETE BINDER COURSE, SUPERPAVE, IL-19.0, N50, 1 1/4 INCH
- (C) - EXISTING PIPE UNDERDRAINS, 4 INCH (STD. 601001)
- (D) - EXISTING SUB-BASE GRANULAR MATERIAL, TYPE C
- (E) - EXISTING BITUMINOUS SHOULDERS, SUPERPAVE, 8 INCH
- (F) - EXISTING AGGREGATE SHOULDERS, TYPE B
- (G) - EXISTING FURNISHING AND PLACING TOPSOIL - 4 INCH
- (H) - EXISTING SOLID CONCRETE MEDIAN, TYPE SM-4.06 (12' OR LESS WIDTH) (STD. 606301)
- (I) - PROPOSED HOT-MIX ASPHALT REMOVAL (SPECIAL), 1/2"
- (J) - PROPOSED CAPE SEAL
- (K) - PROPOSED BITUMINOUS MATERIALS (FOG SEAL)
- (L) - PROPOSED MODIFIED URETHANE PAVEMENT MARKING - LINE 5"
- (M) - EXISTING CONCRETE CURB AND GUTTER TYPE M-4.06 (STD. 606001)

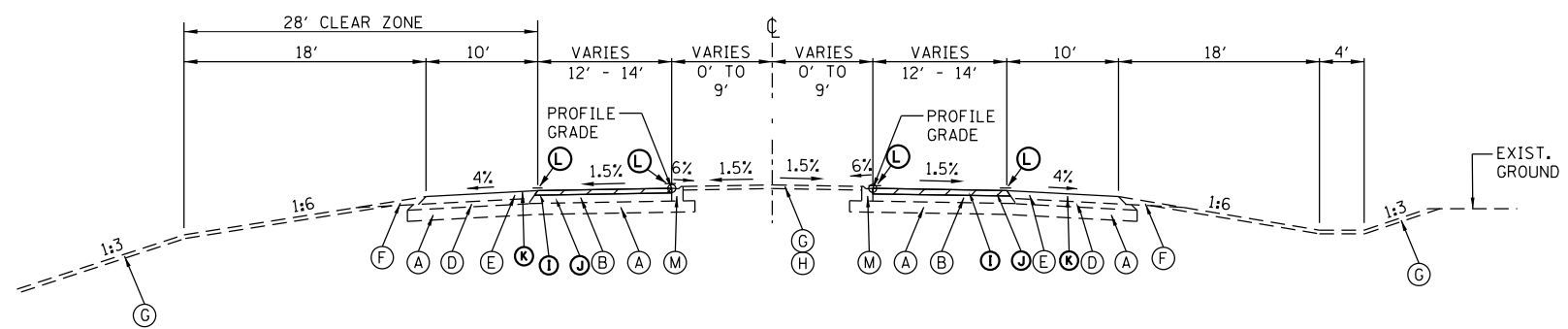

TANGENT TYPICAL SECTION
 STA. 95+38.50 TO STA. 96+03.15
 STA. 103+99.14 TO STA. 108+22.27

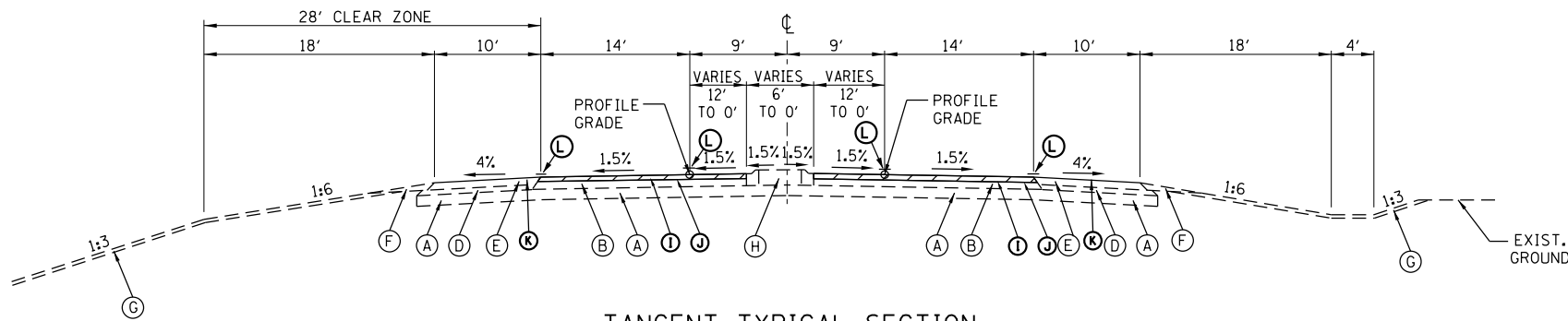

TANGENT TYPICAL SECTION
 STA. 96+03.15 TO STA. 98+68.75
 STA. 98+68.75 TO STA. 98+98.75 BRIDGE APPROACH PAVEMENT (STD. 420401)
 STA. 98+98.75 TO STA. 101+01.25 BRIDGE
 STA. 101+01.25 TO STA. 101+31.25 BRIDGE APPROACH PAVEMENT (STD. 420401)
 STA. 101+31.25 TO STA. 103+99.14

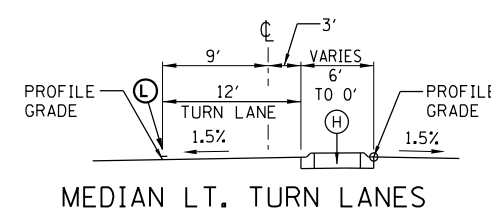

MEDIAN LT. TURN LANES

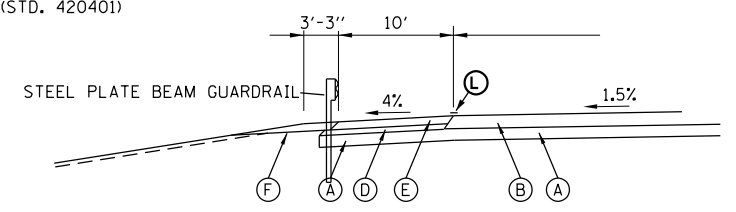

OUTSIDE SHOULDER WITH GUARDRAIL

F.A.P. 302/315
 TYPICAL SECTIONS
 T.R. 184/U.S. 136

MODEL: Default
 FILE: Model: 302/315/184/US/136/TypicalSections/184/US/136/TypicalSections.dgn
 PROJECT: 302/315/184/US/136/TypicalSections/184/US/136/TypicalSections.dgn
 USER: ccoxjw
 PLOT SCALE = 100.0000' / in.
 PLOT DATE = 12/11/2020

USER NAME = ccoxjw	DESIGNED -	REVISED -
	DRAWN -	REVISED -
PLOT SCALE = 100.0000' / in.	CHECKED -	REVISED -
PLOT DATE = 12/11/2020	DATE -	REVISED -

STATE OF ILLINOIS
 DEPARTMENT OF TRANSPORTATION

TYPICAL SECTIONS

SCALE: NTS SHEET 3 OF 4 SHEETS STA. TO STA.

F.A.P. RTE.	SECTION	COUNTY	TOTAL SHEETS	SHEET NO.
302	(34-3) Q	HANCOCK	27	13
CONTRACT NO. 72L72				
ILLINOIS FED. AID PROJECT				

- LEGEND
- (A) - EXISTING LIME MODIFIED SOIL - 12"
 - (B) - EXISTING BITUMINOUS CONCRETE PAVEMENT (FULL DEPTH) SUPERPAVE, 1 3/4 INCH; INCLUDES BITUMINOUS CONCRETE SURFACE COURSE, SUPERPAVE, MIX. "C", N50, 2 INCH, AND BITUMINOUS CONCRETE BINDER COURSE, SUPERPAVE, IL-19.0, N50, 1 1/4 INCH
 - (C) - EXISTING PIPE UNDERDRAINS, 4 INCH (STD. 601001)
 - (D) - EXISTING SUB-BASE GRANULAR MATERIAL, TYPE C
 - (E) - EXISTING BITUMINOUS SHOULDERS, SUPERPAVE, 8 INCH
 - (F) - EXISTING AGGREGATE SHOULDERS, TYPE B
 - (G) - EXISTING FURNISHING AND PLACING TOPSOIL - 4 INCH
 - (H) - EXISTING SOLID CONCRETE MEDIAN, TYPE SM-4.06 (12' OR LESS WIDTH) (STD. 606301)
 - (I) - PROPOSED HOT-MIX ASPHALT REMOVAL (SPECIAL), 1/2"
 - (J) - PROPOSED CAPE SEAL
 - (K) - PROPOSED BITUMINOUS MATERIALS (FOG SEAL)
 - (L) - PROPOSED MODIFIED URETHANE PAVEMENT MARKING - LINE 5"
 - (M) - EXISTING CONCRETE CURB AND GUTTER TYPE M-4.06 (STD. 606001)

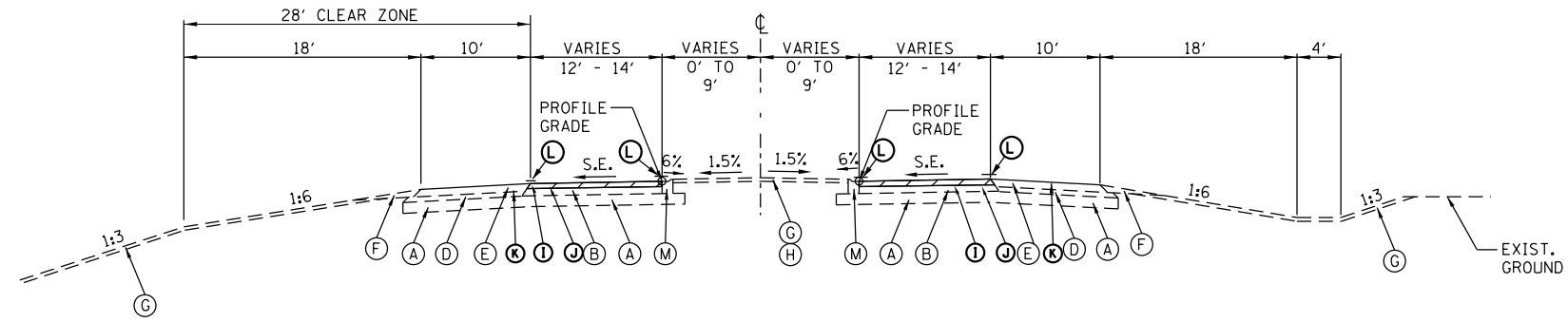

SUPERELEVATED TYPICAL SECTION
 STA. 95+20.00 TO STA. 95+38.50 TANGENT RUNOUT
 STA. 108+22.27 TO STA. 108+59.77 TANGENT RUNOUT
 STA. 108+59.77 TO STA. 110+09.77 SUPERELEVATION RUNOFF
 STA. 110+09.77 TO STA. 111+95.58 FULL SUPERELEVATION (6%)

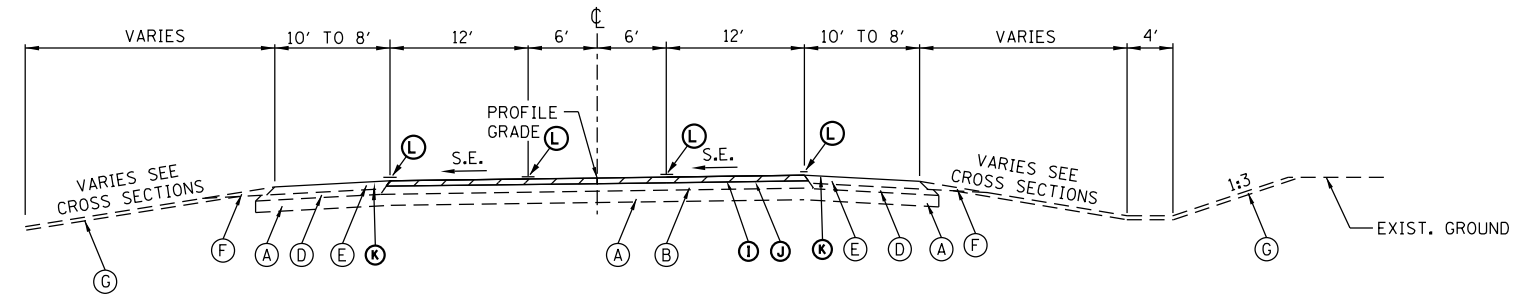

SUPERELEVATED TYPICAL SECTION
 STA. 111+95.58 TO STA. 113+06.88 FULL SUPERELEVATION (6%)

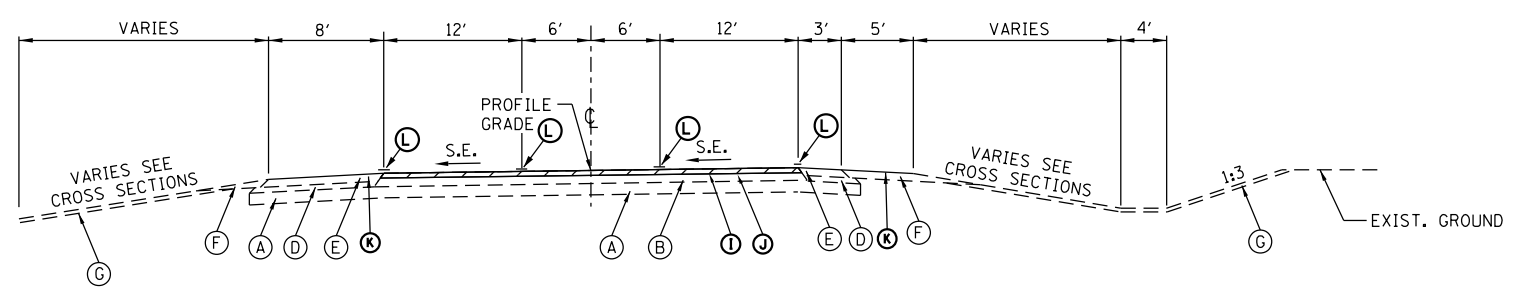

SUPERELEVATED TYPICAL SECTION
 STA. 113+06.88 TO STA. 113+81 FULL SUPERELEVATION (6%)

F.A.P. 302/315
 TYPICAL SECTIONS
 T.R. 184/U.S. 136

MODEL: Default
 FILE: h:\mhc\p\suplanroom\dat\illinois.gov\PWIDOT\Documents\DOT_Offices\District_6\Projects\0672172\CaddData\Cad\Sheets\0672172-rht-typical.dgn

TYPICAL.XRD.DGN

USER NAME = coxjw	DESIGNED -	REVISED -	STATE OF ILLINOIS DEPARTMENT OF TRANSPORTATION	TYPICAL SECTIONS			F.A.P. RTE.	SECTION	COUNTY	TOTAL SHEETS	SHEET NO.
PLOT SCALE = 100,0000' / in.	DRAWN -	REVISED -					302	(34-3) Q	HANCOCK	27	14
PLOT DATE = 12/11/2020	CHECKED -	REVISED -		SCALE: NTS SHEET 4 OF 4 SHEETS STA. TO STA.			CONTRACT NO. 72L72				
	DATE -	REVISED -					ILLINOIS FED. AID PROJECT				

MICROSURFACING SINGLE PASS

BEGIN PROJECT
STA 687+60.5

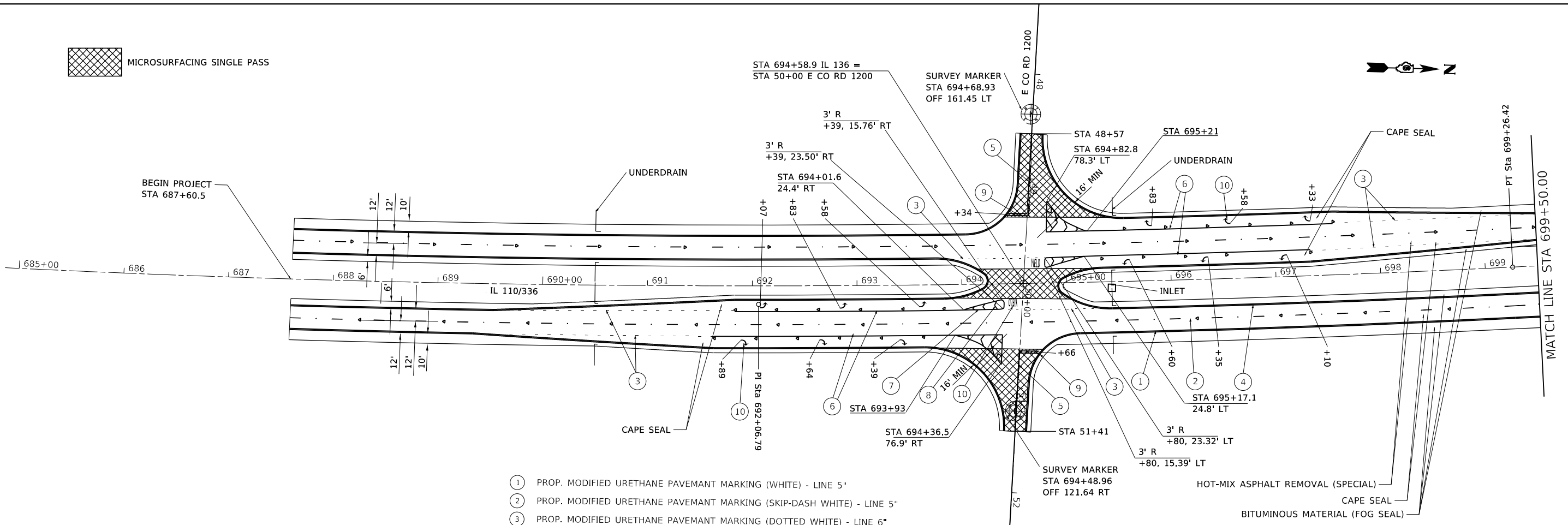

- ① PROP. MODIFIED URETHANE PAVEMENT MARKING (WHITE) - LINE 5"
- ② PROP. MODIFIED URETHANE PAVEMENT MARKING (SKIP-DASH WHITE) - LINE 5"
- ③ PROP. MODIFIED URETHANE PAVEMENT MARKING (DOTTED WHITE) - LINE 6"
- ④ PROP. MODIFIED URETHANE PAVEMENT MARKING (YELLOW) - LINE 5"
- ⑤ PROP. MODIFIED URETHANE PAVEMENT MARKING (DOUBLE YELLOW) - LINE 5"
- ⑥ PROP. MODIFIED URETHANE PAVEMENT MARKING (WHITE) - LINE 6"
- ⑦ PROP. MODIFIED URETHANE PAVEMENT MARKING (WHITE) - LINE 8"
- ⑧ PROP. MODIFIED URETHANE PAVEMENT MARKING (WHITE) - LINE 12"
- ⑨ PROP. MODIFIED URETHANE PAVEMENT MARKING (WHITE) - LINE 24"
- ⑩ PROP. MODIFIED URETHANE PAVEMENT MARKING (WHITE) - LETTERS & SYMBOLS

MICROSURFACING SINGLE PASS

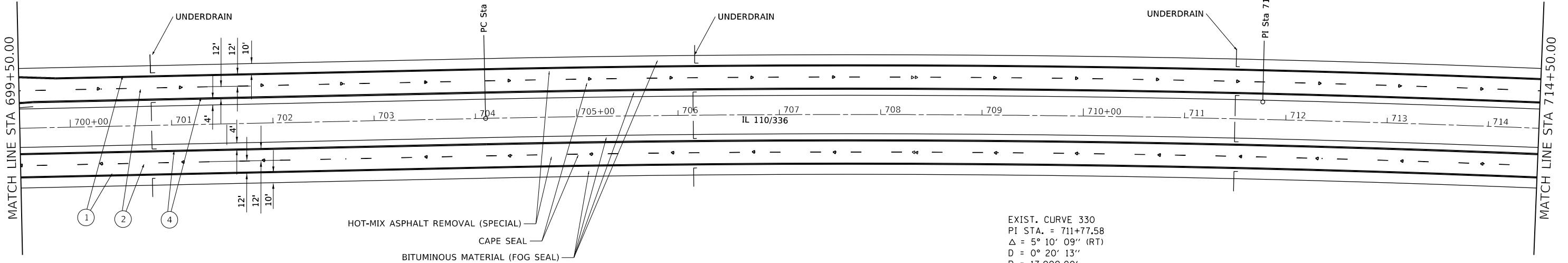

EXIST. CURVE 330
 PI STA. = 711+77.58
 $\Delta = 5^\circ 10' 09''$ (RT)
 $D = 0^\circ 20' 13''$
 $R = 17,000.00'$
 $T = 767.39'$
 $L = 1,533.74'$
 $E = 17.31'$
 $e = N.C.$
 P.C. STA. = 704+10.19
 P.T. STA. = 719+43.93

MODEL: Default
 FILE: Model: P:\pub\planroom.dwg
 PROJECT: 0672172_CADD\Drawings\DOT - Offices\Drawings\0672172-2-17-2020\0672172-2-17-2020.dwg

USER NAME = ccoxjw	DESIGNED -	REVISED -
PLOT SCALE = 100,0000' / in.	DRAWN -	REVISED -
PLOT DATE = 12/11/2020	CHECKED -	REVISED -
	DATE -	REVISED -

**STATE OF ILLINOIS
DEPARTMENT OF TRANSPORTATION**

PLAN SHEET			
SCALE:	SHEET 1	OF 13 SHEETS	STA. TO STA.

F.A.P. RTE.	SECTION	COUNTY	TOTAL SHEETS	SHEET NO.
302	(34-3) RS	HANCOCK	27	15
CONTRACT NO. 72L72				
ILLINOIS FED. AID PROJECT				

MICROSURFACING SINGLE PASS

STA 748+45.6 IL 136 =
STA 50+00 E CO RD 1300

SURVEY MARKER
STA 748+39.38
OFF 105.42 LT

3' R
+26, 13.16' RT

3' R
+26, 24' RT

STA 747+85

UNDERDRAIN

E CO RD 1300

STA 48+63

STA 748+63.5
72.1' LT

STA 748+96.6

CAPE SEAL

UNDERDRAIN

INLET

UNDERDRAIN

MATCH LINE STA 744+50.00

MATCH LINE STA 759+50.00

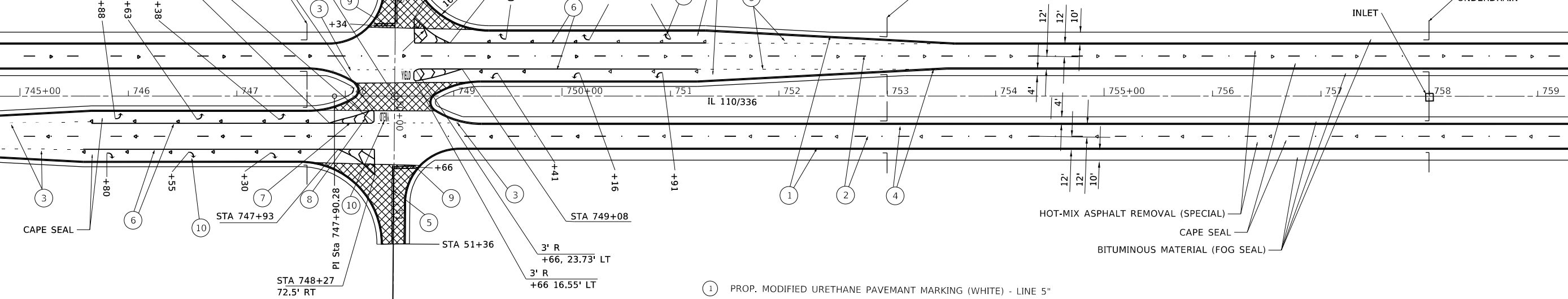

- ① PROP. MODIFIED URETHANE PAVEMANT MARKING (WHITE) - LINE 5"
- ② PROP. MODIFIED URETHANE PAVEMANT MARKING (SKIP-DASH WHITE) - LINE 5"
- ③ PROP. MODIFIED URETHANE PAVEMANT MARKING (DOTTED WHITE) - LINE 6"
- ④ PROP. MODIFIED URETHANE PAVEMANT MARKING (YELLOW) - LINE 5"
- ⑤ PROP. MODIFIED URETHANE PAVEMANT MARKING (DOUBLE YELLOW) - LINE 5"
- ⑥ PROP. MODIFIED URETHANE PAVEMANT MARKING (WHITE) - LINE 6"
- ⑦ PROP. MODIFIED URETHANE PAVEMANT MARKING (WHITE) - LINE 8"
- ⑧ PROP. MODIFIED URETHANE PAVEMANT MARKING (WHITE) - LINE 12"
- ⑨ PROP. MODIFIED URETHANE PAVEMANT MARKING (WHITE) - LINE 24"
- ⑩ PROP. MODIFIED URETHANE PAVEMANT MARKING (WHITE) - LETTERS & SYMBOLS

MICROSURFACING SINGLE PASS

UNDERDRAIN

INLET

UNDERDRAIN

UNDERDRAIN

MATCH LINE STA 759+50.00

MATCH LINE STA 774+50.00

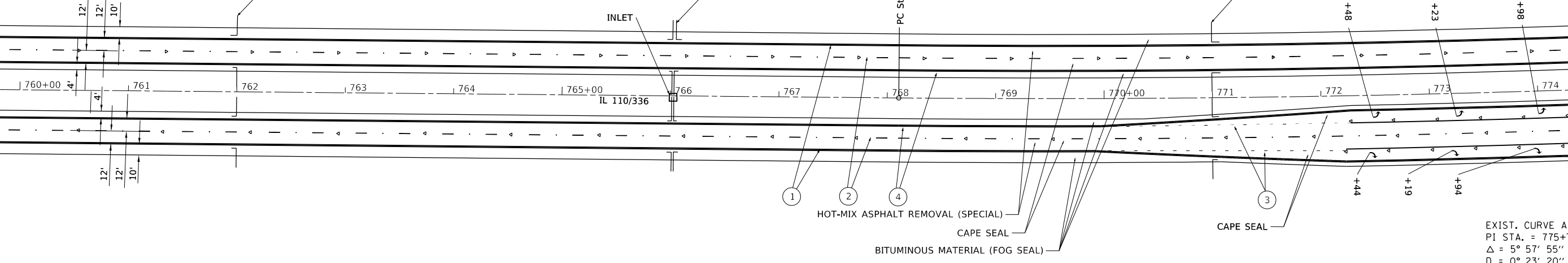

EXIST. CURVE A3
PI STA. = 775+78.47
 $\Delta = 5^\circ 57' 55''$ (LT)
D = $0^\circ 23' 20''$
R = 14,733.20'
T = 767.66'
L = 1,533.93'
E = 19.99'
e = N.C.
P.C. STA. = 768+10.81
P.T. STA. = 783+44.74

MODEL: Default
FILE: h:\mhc\p\suplanroom.d\at\illinois.gov\PI\DOT\Documents\DOT - Offices\District 6\Projects\0672172\Cadd\Drawings\0672172-2-Plan.dgn

USER NAME = coxjw	DESIGNED -	REVISED -
	DRAWN -	REVISED -
PLOT SCALE = 100.0000' / in.	CHECKED -	REVISED -
PLOT DATE = 12/11/2020	DATE -	REVISED -

**STATE OF ILLINOIS
DEPARTMENT OF TRANSPORTATION**

PLAN SHEET

SCALE: SHEET 3 OF 13 SHEETS STA. TO STA.

F.A.P. RTE.	SECTION	COUNTY	TOTAL SHEETS	SHEET NO.
302	(34-3) RS	HANCOCK	27	17
			CONTRACT NO. 72L72	
ILLINOIS FED. AID PROJECT				

MICROSURFACING SINGLE PASS

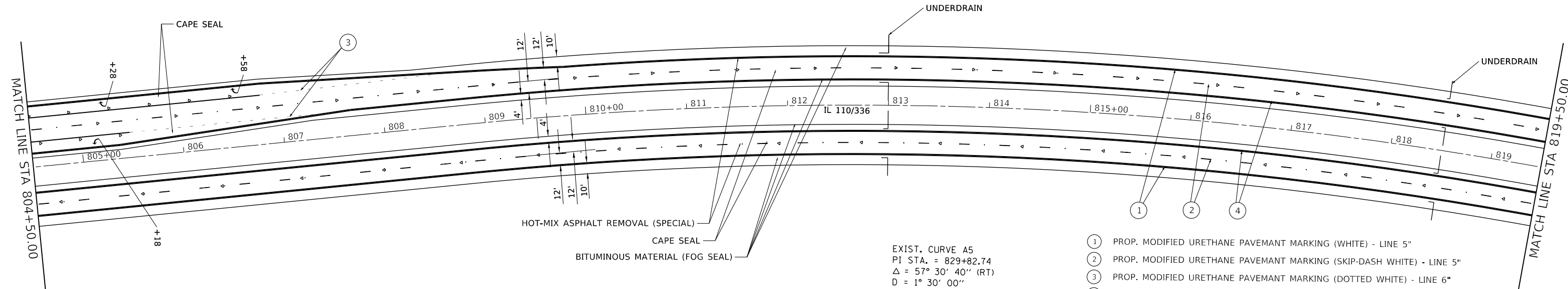

EXIST. CURVE A5
 PI STA. = 829+82.74
 $\Delta = 57^\circ 30' 40''$ (RT)
 $D = 1^\circ 30' 00''$
 $R = 3,819.72'$
 $T = 2,096.05'$
 $L = 3,834.07'$
 $E = 537.31'$
 $e = 4.6\%$
 $T.R. = 45'$
 $S.E. RUN = 210'$
 $P.C. STA. = 808+86.69$
 $P.T. STA. = 847+20.77$

- ① PROP. MODIFIED URETHANE PAVEMENT MARKING (WHITE) - LINE 5"
- ② PROP. MODIFIED URETHANE PAVEMENT MARKING (SKIP-DASH WHITE) - LINE 5"
- ③ PROP. MODIFIED URETHANE PAVEMENT MARKING (DOTTED WHITE) - LINE 6"
- ④ PROP. MODIFIED URETHANE PAVEMENT MARKING (YELLOW) - LINE 5"
- ⑤ PROP. MODIFIED URETHANE PAVEMENT MARKING (DOUBLE YELLOW) - LINE 5"
- ⑥ PROP. MODIFIED URETHANE PAVEMENT MARKING (WHITE) - LINE 6"
- ⑦ PROP. MODIFIED URETHANE PAVEMENT MARKING (WHITE) - LINE 8"
- ⑧ PROP. MODIFIED URETHANE PAVEMENT MARKING (WHITE) - LINE 12"
- ⑨ PROP. MODIFIED URETHANE PAVEMENT MARKING (WHITE) - LINE 24"
- ⑩ PROP. MODIFIED URETHANE PAVEMENT MARKING (WHITE) - LETTERS & SYMBOLS

MICROSURFACING SINGLE PASS

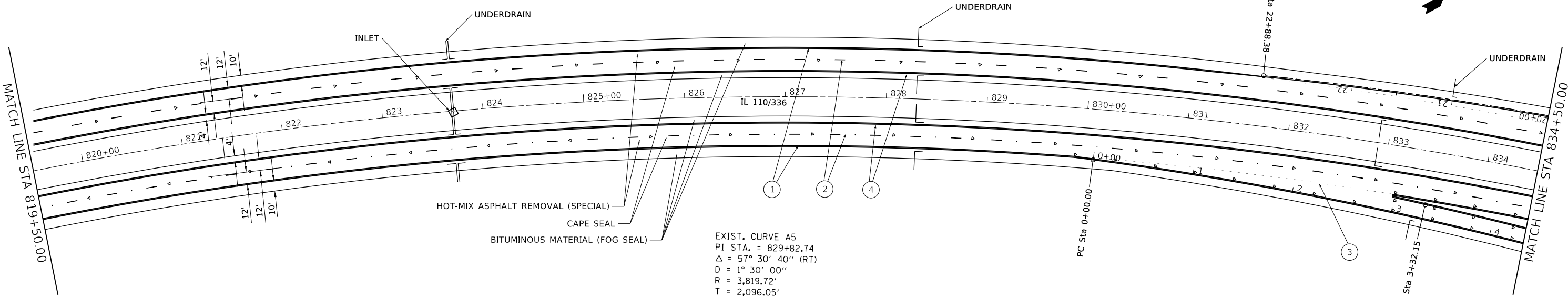
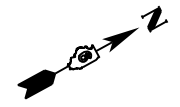

EXIST. CURVE A5
 PI STA. = 829+82.74
 $\Delta = 57^\circ 30' 40''$ (RT)
 $D = 1^\circ 30' 00''$
 $R = 3,819.72'$
 $T = 2,096.05'$
 $L = 3,834.07'$
 $E = 537.31'$
 $e = 4.6\%$
 $T.R. = 45'$
 $S.E. RUN = 210'$
 $P.C. STA. = 808+86.69$
 $P.T. STA. = 847+20.77$

- ① PROP. MODIFIED URETHANE PAVEMENT MARKING (WHITE) - LINE 5"
- ② PROP. MODIFIED URETHANE PAVEMENT MARKING (SKIP-DASH WHITE) - LINE 5"
- ③ PROP. MODIFIED URETHANE PAVEMENT MARKING (DOTTED WHITE) - LINE 6"

MODEL: Default
 FILE: Model: Plan: 72L72.dwg
 PROJECT: 0672172_CADD\Drawings\DOT - Office\Drawings\0672172-Subplan.dwg
 USER: ccoxjw

USER NAME = ccoxjw	DESIGNED -	REVISED -
DRAWN -	REVISOR -	
PLOT SCALE = 100,0000' / in.	CHECKED -	REVISOR -
PLOT DATE = 12/11/2020	DATE -	REVISOR -

**STATE OF ILLINOIS
 DEPARTMENT OF TRANSPORTATION**

PLAN SHEET
 SCALE: SHEET 5 OF 13 SHEETS STA. TO STA.

F.A.P. RTE.	SECTION	COUNTY	TOTAL SHEETS	SHEET NO.
302	(34-3) R5	HANCOCK	27	19
CONTRACT NO. 72L72				
ILLINOIS FED. AID PROJECT				

MICROSURFACING SINGLE PASS

EXIST. CURVE B2
 PI STA. = 939+39.27
 $\Delta = 6^\circ 06' 34''$ (LT)
 D = 0° 23' 20''
 R = 14,733.20'
 T = 786.25'
 L = 1,571.00'
 E = 20.96'
 e = N.C.
 P.C. STA. = 931+53.03
 P.T. STA. = 947+24.03

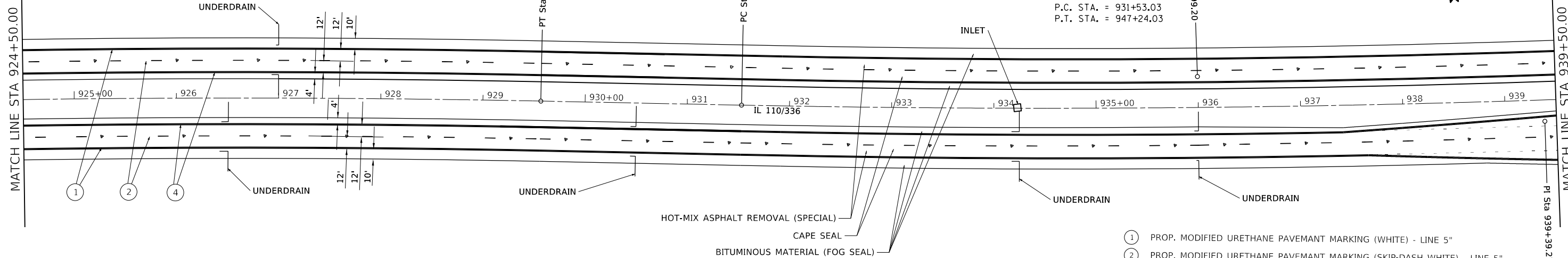

- ① PROP. MODIFIED URETHANE PAVEMENT MARKING (WHITE) - LINE 5"
- ② PROP. MODIFIED URETHANE PAVEMENT MARKING (SKIP-DASH WHITE) - LINE 5"
- ③ PROP. MODIFIED URETHANE PAVEMENT MARKING (DOTTED WHITE) - LINE 6"
- ④ PROP. MODIFIED URETHANE PAVEMENT MARKING (YELLOW) - LINE 5"
- ⑤ PROP. MODIFIED URETHANE PAVEMENT MARKING (DOUBLE YELLOW) - LINE 5"
- ⑥ PROP. MODIFIED URETHANE PAVEMENT MARKING (WHITE) - LINE 6"
- ⑦ PROP. MODIFIED URETHANE PAVEMENT MARKING (WHITE) - LINE 8"
- ⑧ PROP. MODIFIED URETHANE PAVEMENT MARKING (WHITE) - LINE 12"
- ⑨ PROP. MODIFIED URETHANE PAVEMENT MARKING (WHITE) - LINE 24"
- ⑩ PROP. MODIFIED URETHANE PAVEMENT MARKING (WHITE) - LETTERS & SYMBOLS

MICROSURFACING SINGLE PASS

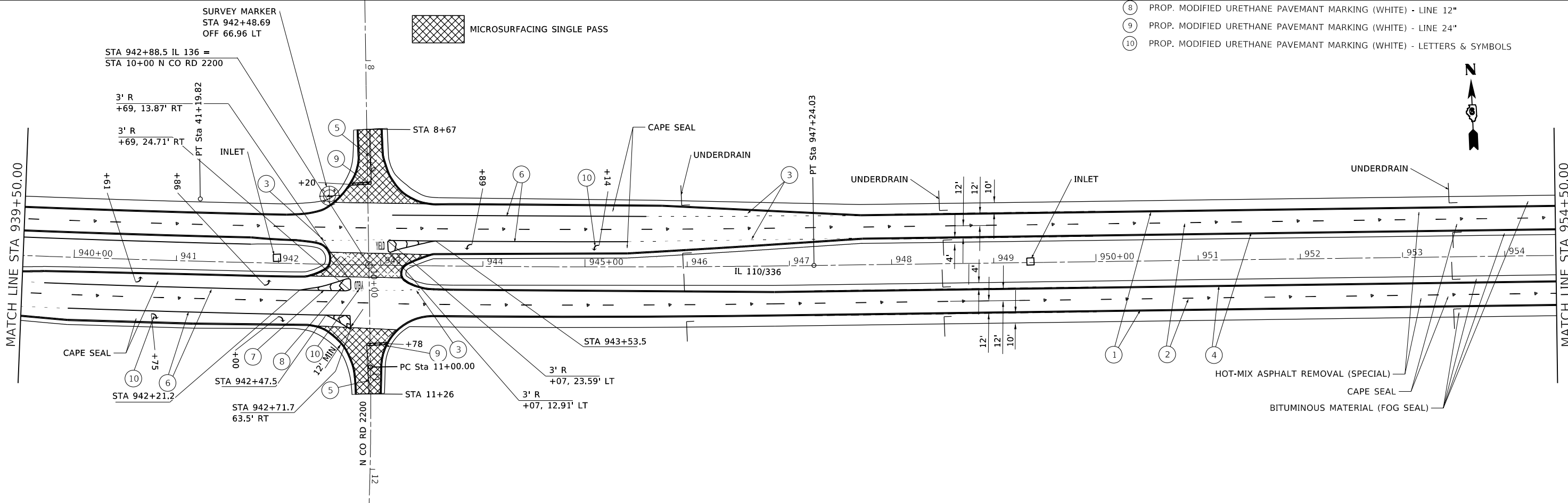

MODEL: Default
 FILE: h:\mhc\p\suplanroom.d\illinois.gov\PIWDOT\Documents\DOT - Offices\District 6\Projects\0672172\Cadd\plan\0672172-23-Plan1.dgn

USER NAME = coxjw	DESIGNED -	REVISED -
PLOT SCALE = 100,0000' / in.	DRAWN -	REVISED -
PLOT DATE = 12/11/2020	CHECKED -	REVISED -
	DATE -	REVISED -

**STATE OF ILLINOIS
 DEPARTMENT OF TRANSPORTATION**

PLAN SHEET
 SCALE: SHEET 9 OF 13 SHEETS STA. TO STA.

F.A.P. RTE.	SECTION	COUNTY	TOTAL SHEETS	SHEET NO.
302	(34-3) RS	HANCOCK	27	23
CONTRACT NO. 72L72				
ILLINOIS FED. AID PROJECT				

MICROSURFACING SINGLE PASS



SURVEY MARKER
STA 969+10.11
OFF 71.99 LT

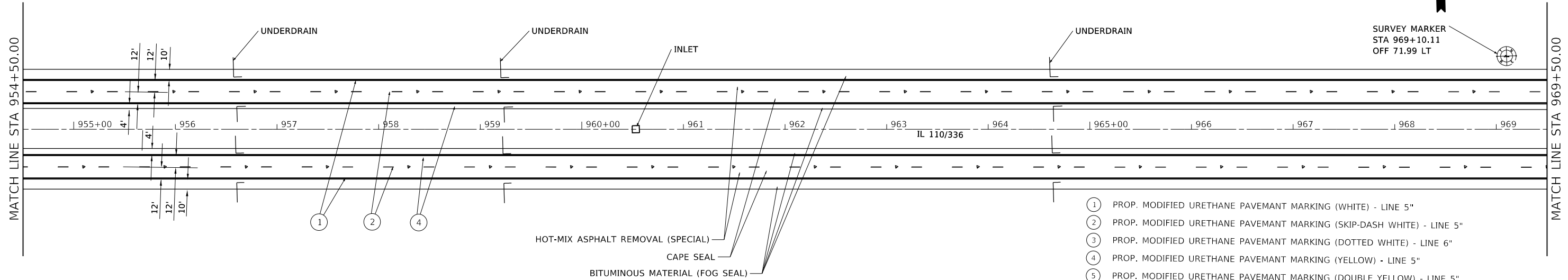

- ① PROP. MODIFIED URETHANE PAVEMANT MARKING (WHITE) - LINE 5"
- ② PROP. MODIFIED URETHANE PAVEMANT MARKING (SKIP-DASH WHITE) - LINE 5"
- ③ PROP. MODIFIED URETHANE PAVEMANT MARKING (DOTTED WHITE) - LINE 6"
- ④ PROP. MODIFIED URETHANE PAVEMANT MARKING (YELLOW) - LINE 5"
- ⑤ PROP. MODIFIED URETHANE PAVEMANT MARKING (DOUBLE YELLOW) - LINE 5"
- ⑥ PROP. MODIFIED URETHANE PAVEMANT MARKING (WHITE) - LINE 6"
- ⑦ PROP. MODIFIED URETHANE PAVEMANT MARKING (WHITE) - LINE 8"
- ⑧ PROP. MODIFIED URETHANE PAVEMANT MARKING (WHITE) - LINE 12"
- ⑨ PROP. MODIFIED URETHANE PAVEMANT MARKING (WHITE) - LINE 24"
- ⑩ PROP. MODIFIED URETHANE PAVEMANT MARKING (WHITE) - LETTERS & SYMBOLS

MICROSURFACING SINGLE PASS

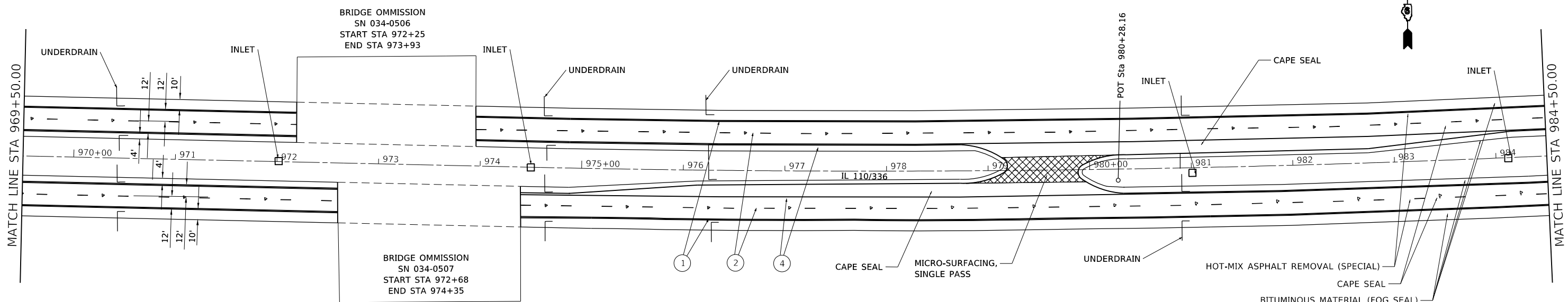

- ① PROP. MODIFIED URETHANE PAVEMANT MARKING (WHITE) - LINE 5"
- ② PROP. MODIFIED URETHANE PAVEMANT MARKING (SKIP-DASH WHITE) - LINE 5"
- ③ PROP. MODIFIED URETHANE PAVEMANT MARKING (DOTTED WHITE) - LINE 6"
- ④ PROP. MODIFIED URETHANE PAVEMANT MARKING (YELLOW) - LINE 5"
- ⑤ PROP. MODIFIED URETHANE PAVEMANT MARKING (DOUBLE YELLOW) - LINE 5"
- ⑥ PROP. MODIFIED URETHANE PAVEMANT MARKING (WHITE) - LINE 6"
- ⑦ PROP. MODIFIED URETHANE PAVEMANT MARKING (WHITE) - LINE 8"
- ⑧ PROP. MODIFIED URETHANE PAVEMANT MARKING (WHITE) - LINE 12"
- ⑨ PROP. MODIFIED URETHANE PAVEMANT MARKING (WHITE) - LINE 24"
- ⑩ PROP. MODIFIED URETHANE PAVEMANT MARKING (WHITE) - LETTERS & SYMBOLS

MODEL: Default
 FILE: h:\m\c\p\suplanroom.dwg
 PROJECT: 0672172_CADD\Drawings\DOT_Offices\Drawings\0672172-Subplan.dwg

USER NAME = ccoxjw	DESIGNED -	REVISED -
	DRAWN -	REVISED -
PLOT SCALE = 100,0000' / in.	CHECKED -	REVISED -
PLOT DATE = 12/11/2020	DATE -	REVISED -

**STATE OF ILLINOIS
DEPARTMENT OF TRANSPORTATION**

PLAN SHEET			
SCALE:	SHEET 10	OF 13 SHEETS	STA. TO STA.

F.A.P. RTE.	SECTION	COUNTY	TOTAL SHEETS	SHEET NO.
302	(34-3) RS	HANCOCK	27	24
CONTRACT NO. 72L72				
ILLINOIS FED. AID PROJECT				

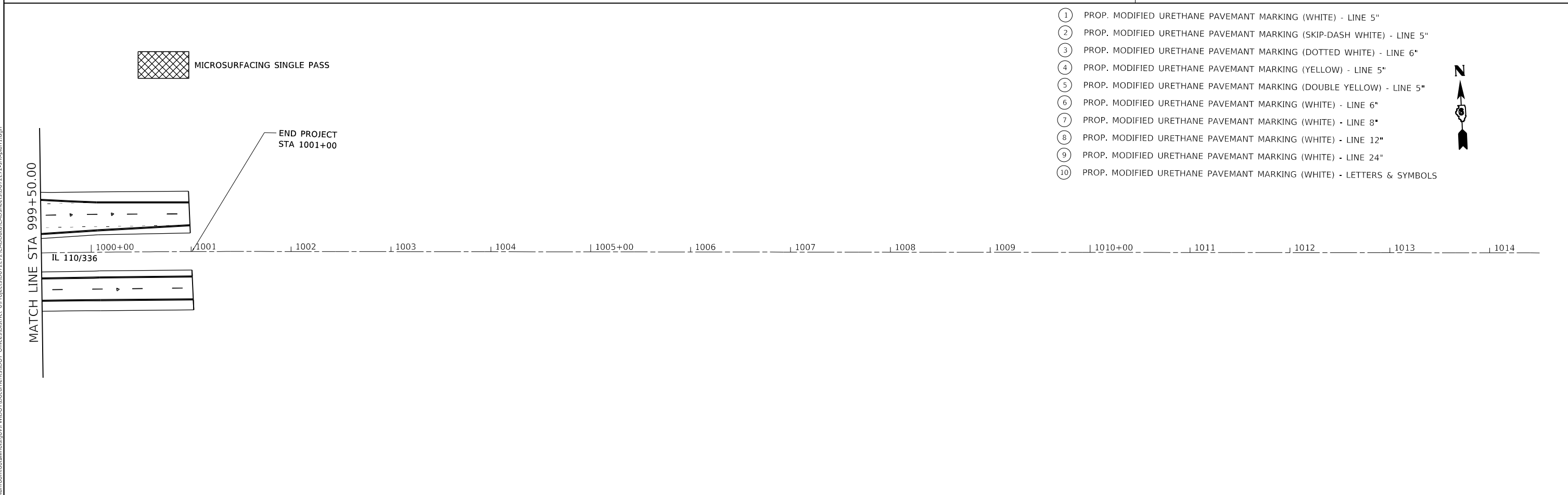
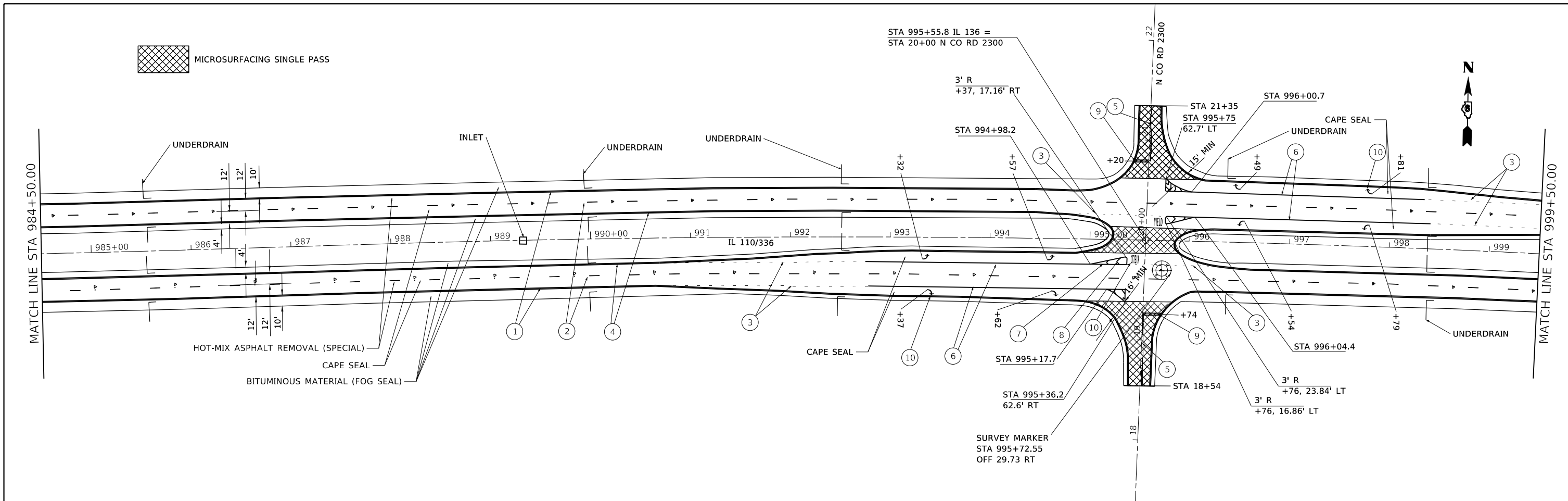

MODEL: Default
 FILE: \\blm1c1.pw.us\pub\lancorn.dwg
 PROJECT: \\blm1c1.pw.us\pub\lancorn.dwg
 OFFICE: \\blm1c1.pw.us\pub\lancorn.dwg
 DATE: 12/11/2020

USER NAME = coxjw	DESIGNED -	REVISED -
PLOT SCALE = 100.0000' / in.	DRAWN -	REVISED -
PLOT DATE = 12/11/2020	CHECKED -	REVISED -
	DATE -	REVISED -

**STATE OF ILLINOIS
DEPARTMENT OF TRANSPORTATION**

PLAN SHEET			
SCALE:	SHEET 11	OF 13 SHEETS	STA. TO STA.

F.A.P. RTE.	SECTION	COUNTY	TOTAL SHEETS	SHEET NO.
302	(34-3) RS	HANCOCK	27	25
CONTRACT NO. 72L72				
ILLINOIS FED. AID PROJECT				

MODEL: Default
 FILE: h:\a\c\p\suplanroom\dat\illinois\gov\p\w\dot\Documents\DOT_Offices\Illin\ct 6\Projects\0672172\CADD\data\CAD\sheet\0672172-sh13plan.dgn



MICROSURFACING SINGLE PASS

EXIST. CURVE Z-1
 PI STA. = 91+61.25
 $\Delta = 33^\circ 52' 04''$ (LT)
 $D = 6^\circ 51' 00''$
 $R = 836.43'$
 $T = 254.67'$
 $L = 494.42'$
 $E = 37.91'$
 $e = 6\%$
 $T.R. = 37.5'$
 $S.E. RUN = 150'$
 $P.C. STA. = 89+06.59$
 $P.T. STA. = 94+01.01$

- ① PROP. MODIFIED URETHANE PAVEMENT MARKING (WHITE) - LINE 5"
- ② PROP. MODIFIED URETHANE PAVEMENT MARKING (SKIP-DASH WHITE) - LINE 5"
- ③ PROP. MODIFIED URETHANE PAVEMENT MARKING (DOTTED WHITE) - LINE 6"
- ④ PROP. MODIFIED URETHANE PAVEMENT MARKING (YELLOW) - LINE 5"
- ⑤ PROP. MODIFIED URETHANE PAVEMENT MARKING (DOUBLE YELLOW) - LINE 5"
- ⑥ PROP. MODIFIED URETHANE PAVEMENT MARKING (WHITE) - LINE 6"
- ⑦ PROP. MODIFIED URETHANE PAVEMENT MARKING (WHITE) - LINE 8"
- ⑧ PROP. MODIFIED URETHANE PAVEMENT MARKING (WHITE) - LINE 12"
- ⑨ PROP. MODIFIED URETHANE PAVEMENT MARKING (WHITE) - LINE 24"
- ⑩ PROP. MODIFIED URETHANE PAVEMENT MARKING (WHITE) - LETTERS & SYMBOLS

USER NAME = coxjw	DESIGNED -	REVISED -
	DRAWN -	REVISED -
PLOT SCALE = 100,0000' / in.	CHECKED -	REVISED -
PLOT DATE = 12/11/2020	DATE -	REVISED -

**STATE OF ILLINOIS
 DEPARTMENT OF TRANSPORTATION**

PLAN SHEET			
SCALE:	SHEET 13	OF 13 SHEETS	STA. TO STA.

F.A.P. RTE.	SECTION	COUNTY	TOTAL SHEETS	SHEET NO.
302	(334-3) RS	HANCOCK	27	27
CONTRACT NO. 72L72				
ILLINOIS FED. AID PROJECT				