

STATE OF ILLINOIS
DEPARTMENT OF TRANSPORTATION

F.A.P. RTE.	SECTION	COUNTY	TOTAL SHEETS
832	(113,114)RS-4	CLARK	46
ILLINOIS CONTRACT 74945			

FOR INDEX OF SHEETS, SEE SHEET NO. 2

**PROPOSED
HIGHWAY PLANS**

F.A.P. ROUTE 832 (ILL 49)
SECTION (113,114)RS-4
PROJECT STP-G1BU(003)
3P RESURFACING
CLARK COUNTY

C-97-021-20

ADT = 1,900 (2019)
18.4% TRUCKS

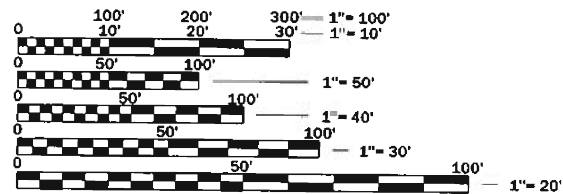
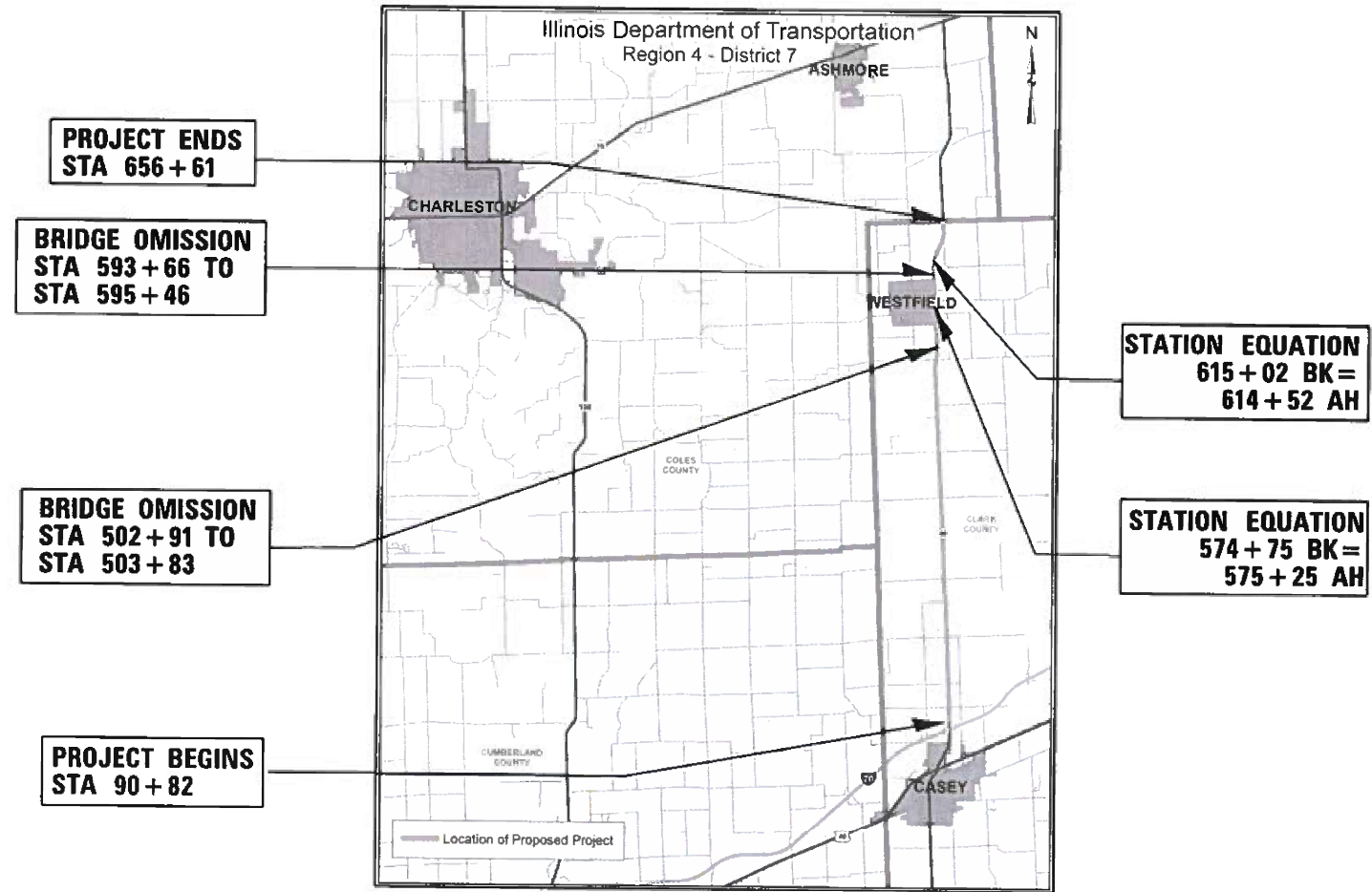

FULL SIZE PLANS HAVE BEEN PREPARED USING STANDARD ENGINEERING SCALES. REDUCED SIZED PLANS WILL NOT CONFORM TO STANDARD SCALES. IN MAKING MEASUREMENTS ON REDUCED PLANS, THE ABOVE SCALES MAY BE USED.

J.U.L.I.E.
JOINT UTILITY LOCATION INFORMATION FOR EXCAVATION
1-800-892-0123
OR 811

PROJECT ENGINEER: BRIAN LEWIS
PROJECT MANAGER: MINDY JANSEN

CONTRACT NO. 74945

GROSS LENGTH = 56,579.00 FT. = 10.715 MILE
NET LENGTH = 56,307.00 FT. = 10.664 MILE

STATE OF ILLINOIS
DEPARTMENT OF TRANSPORTATION

SUBMITTED Dec 14 2020
[Signature] REGIONAL ENGINEER

January 29, 2021
[Signature] ENGINEER OF DESIGN AND ENVIRONMENT

January 29, 2021
[Signature] DIRECTOR OF HIGHWAYS PROJECT IMPLEMENTATION

**PRINTED BY THE AUTHORITY
OF THE STATE OF ILLINOIS**

GENERAL NOTES

THIS PROJECT IS LOCATED 0.3 MILES NORTH OF I-70 IN CASEY ALONG ILL 49 AND EXTENDS 10.73 MILES TO THE COLES COUNTY LINE.

THE WORK INCLUDED IN SECTION (113,114)RS-4 CONSISTS OF PATCHING, HMA SURFACE REMOVAL, HMA RESURFACING, AGGREGATE SHOULDERS, INCIDENTAL HMA, PAINT PAVEMENT MARKINGS, RAISED REFLECTIVE MARKINGS, PROTECTING OR RESETTING SURVEY MARKERS, AND OTHER WORK NECESSARY TO COMPLETE THIS SECTION. THERE ARE TWO BRIDGE STRUCTURES WITH PROPOSED WORK. STRUCTURE 012-0061 CONSISTS OF PATCHING WORK, CONCRETE DECK OVERLAY, AND BRIDGE APPROACH SLABS AND CONNECTOR. STRUCTURE 012-0066 CONSISTS OF PATCHING AND CONCRETE DECK OVERLAY. CULVERT STRUCTURE 012-8633 IS PROPOSED TO BE REPLACED,

WHEN APPLYING SHORT TERM PAVEMENT MARKINGS, TEMPORARY TAPE SHALL BE USED ON THE SURFACE AND PAINT SHALL BE USED ON THE MILLED SURFACES.

MATERIAL FOR AGGREGATE SHOULDERS TYBE B, SHALL BE CRUSHED STONE OR CRUSHED CONCRETE. MATERIAL FOR AGGREGATE SURFACE COURSE, TYPE B SHALL BE CRUSHED STONE OR CRUSHED CONCRETE.

CONTRACTOR SHALL CONSTRUCT 10" SHOULDERS IN 2-4" LIFTS WITH HMA BINDER COURSE AND THEN A LIFT WITH HMA SURFACE COURSE.

MIXTURE REQUIREMENTS

THE FOLLOWING MIXTURE REQUIREMENTS ARE APPLICABLE TO THIS PROJECT:

APPLICATION	AC/PG	DESIGN AIR Voids	MIXTURE COMPOSITION	FRICTION AGGREGATE	QUALITY MANAGEMENT
HMA SURFACE COURSE, MIX "C", N70 (1 1/2")	PG 64-22	4.0% @ N=70	IL - 9.5	MIXTURE C	PFP
HMA BINDER COURSE, IL-9.5FG, N70, (1 1/4")	PG 64-22	4.0% @ N=70	IL - 9.5FG	N/A	PFP
INCIDENTAL HMA SURFACING	PG 64-22	4.0% @ N=70	IL - 9.5	MIXTURE C	QC/QA
CLASS "D" PAVEMENT PATCHING	PG 64-22	4.0% @ N=70	IL - 19.0	N/A	QC/QA
HMA SHOULDERS, 10" (TOP LIFT)	PG 64-22	4.0% @ N=70	IL - 9.5	MIXTURE C	QC/QA
HMA SHOULDERS, 10" (BOTTOM LIFTS)	PG 64-22	4.0% @ N=70	IL - 19.0	N/A	QC/QA
HMA FLEXIBLE CONNECTOR (TOP LIFT)	PG 64-22	4.0% @ N=70	IL - 9.5	MIXTURE C	QC/QA
HMA FLEXIBLE CONNECTOR (BOTTOM LIFT)	PG 64-22	4.0% @ N=70	IL - 19.0	N/A	QC/QA

APPLICATION RATES

THE FOLLOWING APPLICATION RATES WERE USED IN CALCULATING PLAN QUANTITIES AND HAVE BEEN INCLUDED FOR REFERENCE:

AGGREGATE SURFACE COURSE AND SHOULDER	2.05 TON/CU YD
BITUMINOUS MATERIALS (TACK COAT)	0.5 LB/SQ FT (ON MILLED SURFACES)
	0.025 LB/SQ FT (ON HMA LIFTS)
HOT-MIX ASPHALT BINDERS AND SURFACES	112 LB/SQ YD/INCH

INDEX OF SHEETS

SHEET NO.	ITEM
1	COVER SHEET
2	INDEX OF SHEETS, LIST OF STANDARDS, AND GENERAL NOTES
3-5	SUMMARY OF QUANTITIES
6-9	TYPICAL SECTIONS
10-13	SCHEDULE OF QUANTITIES
14-18	PLAN SHEETS
19-22	STAGING PLAN SHEETS
23	DETOUR PLAN
24-36	STRUCTURAL DETAILS
37-38	PAVING DETAILS
39-40	SUPERELEVATION TRANSITION DETAILS
41-46	MISCELLANEOUS DETAILS

THE FOLLOWING STANDARDS ARE A PART OF THESE PLANS AND ARE INCLUDED AFTER SHEET NO. 27:

STANDARD NO.	DESCRIPTION
000001-08	STANDARD SYMBOLS, ABBREVIATIONS AND PATTERNS
001006	DECIMAL OF AN INCH AND OF A FOOT
406201-01	MAILBOX TURNOUT
442201-03	CLASS C AND D PATCHES
420406	PAVEMENT CONNECTOR (HMA) FOR BRIDGE APPROACH SLAB
482001-02	HMA SHOULDER ADJACENT TO FLEXIBLE PAVEMENT
515001-04	NAME PLATE FOR BRIDGES
667101-02	PERMANENT SURVEY MARKERS
701001-02	OFF-ROAD OPERATIONS, 2L, 2W, MORE THAN 15' AWAY
701006-05	OFF-ROAD OPERATIONS, 2L, 2W, 15' TO 24' FROM PAVEMENT EDGE
701201-05	LANE CLOSURE, 2L, 2W, DAY ONLY, FOR SPEEDS ≥ 45 MPH
701301-04	LANE CLOSURE, 2L, 2W, SHORT TIME OPERATIONS
701306-04	LANE CLOSURE, 2L, 2W, SLOW MOVING OPERATIONS DAY ONLY, FOR SPEEDS ≥ 45 MPH
701311-03	LANE CLOSURE, 2L, 2W, MOVING OPERATIONS - DAY ONLY
701321-18	LANE CLOSURE, 2L, 2W, BRIDGE REPAIR WITH BARRIER
701901-08	TRAFFIC CONTROL DEVICES
704001-08	TEMPORARY CONCRETE BARRIER
B.L.R. 21-9	TYPICAL APPLICATION OF TRAFFIC CONTROL DEVICES FOR CONSTRUCTION ON RURAL LOCAL HIGHWAYS
780001-05	TYPICAL PAVEMENT MARKINGS
781001-04	TYPICAL APPLICATIONS RAISED REFLECTIVE PAVEMENT MARKERS

REV. - MS

MODEL: Default
FILE NAME: p:\p1\barcom.dct_illinois.gov\PIV\DOT\Documents\DOT_Offices\District_7\Projects\74945\CADD\data\CAD\sheet\74945-rlt-genote.dgn

USER NAME = steffenmk	DESIGNED -	REVISED -
	DRAWN -	REVISED -
PLOT SCALE = 100.0000' / in.	CHECKED -	REVISED -
PLOT DATE = 12/17/2020	DATE -	REVISED -

**STATE OF ILLINOIS
DEPARTMENT OF TRANSPORTATION**

INDEX OF SHEETS & GENERAL NOTES

SCALE: SHEET 1 OF 1 SHEETS STA. TO STA.

F.A.P. RTE.	SECTION	COUNTY	TOTAL SHEETS	SHEET NO.
832	(113,114)RS-4	CLARK	46	2
			CONTRACT NO. 74945	
ILLINOIS FED. AID PROJECT				

80% FED
20% STATE

80% FED
20% STATE

SUMMARY OF QUANTITIES			TOTAL QUANTITIES	CONSTRUCTION TYPE CODE		
CODE NO	ITEM	UNIT		0005	0004	0047
20200600	EXCAVATING AND GRADING EXISTING SHOULDER	UNIT	6	6		
20700220	POROUS GRANULAR EMBANKMENT	CU YD	37		37	
40200800	AGGREGATE SURFACE COURSE, TYPE B	TON	21	21		
40600290	BITUMINOUS MATERIALS (TACK COAT)	POUND	103094	103094		
40600990	TEMPORARY RAMP	SO YD	752	752		
40602970	HOT-MIX ASPHALT BINDER COURSE, IL-9.5FG, N70	TON	10679	10679		
40604052	HOT-MIX ASPHALT SURFACE COURSE, IL-9.5, MIX "C", N70	TON	12834	12834		
40800050	INCIDENTAL HOT-MIX ASPHALT SURFACING	TON	540	540		
42000070	PAVEMENT CONNECTOR (HMA) FOR BRIDGE APPROACH SLAB	SO YD	71		71	
44000155	HOT-MIX ASPHALT SURFACE REMOVAL, 1 1/2"	SO YD	150870	150870		
44000160	HOT-MIX ASPHALT SURFACE REMOVAL, 2 3/4"	SO YD	1506	1506		
44201815	CLASS D PATCHES, TYPE II, 14 INCH	SO YD	296	296		
44201819	CLASS D PATCHES, TYPE III, 14 INCH	SO YD	32	32		

SUMMARY OF QUANTITIES			TOTAL QUANTITIES	CONSTRUCTION TYPE CODE		
CODE NO	ITEM	UNIT		0005	0004	0047
44201821	CLASS D PATCHES, TYPE IV, 14 INCH	SO YD	91	53	38	
48101200	AGGREGATE SHOULDERS, TYPE B	TON	5535	5535		
48203037	HOT-MIX ASPHALT SHOULDERS, 10"	SO YD	170	170		
50100300	REMOVAL OF EXISTING STRUCTURES NO. 1	EACH	1		1	
50300225	CONCRETE STRUCTURES	CU YD	21.2			21.2
50300260	BRIDGE DECK GROOVING	SO YD	781			781
50300300	PROTECTIVE COAT	SO YD	844			844
50301350	CONCRETE SUPERSTRUCTURE (APPROACH SLAB)	CU YD	95.8			95.8
50800205	REINFORCEMENT BARS, EPOXY COATED	POUND	37850			37850
50800515	BAR SPLICERS	EACH	290			290
54001001	BOX CULVERT END SECTIONS, CULVERT NO. 1	EACH	2		2	
54010803	PRECAST CONCRETE BOX CULVERTS 8' X 3'	FOOT	42		42	
59100100	GEOCOMPOSITE WALL DRAIN	SQ YD	53		53	
60260100	INLETS TO BE ADJUSTED	EACH	4			4

REV. - MS

MODEL: Default
 FILE: \\mhc-pw\pub\harcam.dwg
 ILLINOIS.GOV.PWD\DOT\Documents\DOT_Offices\District 7\Projects\74945\CADD\Drawings\CAD\Drawings\74945-ph-500.dgn

USER NAME = steffennk	DESIGNED -	REVISED -
	DRAWN -	REVISED -
PLOT SCALE = 100.0000' / in.	CHECKED -	REVISED -
PLOT DATE = 12/17/2020	DATE -	REVISED -

STATE OF ILLINOIS
DEPARTMENT OF TRANSPORTATION

SUMMARY OF QUANTITIES

SCALE: SHEET 1 OF 3 SHEETS STA. TO STA.

F.A.P. RTE.	SECTION	COUNTY	TOTAL SHEETS	SHEET NO.
832	(113,114)RS-4	CLARK	46	3
CONTRACT NO. 74945			ILLINOIS FED. AID PROJECT	

80% FED
20% STATE

80% FED
20% STATE

SUMMARY OF QUANTITIES			TOTAL QUANTITIES	CONSTRUCTION TYPE CODE		
CODE NO	ITEM	UNIT		0005	0004	0047
* 63301210	REMOVE AND REERECT STEEL PLATE BEAM GUARDRAIL, TYPE A	FOOT	100		100	
* 63302700	REMOVE AND REERECT TRAFFIC BARRIER TERMINALS, TYPE 6	EACH	4		4	
66700205	PERMANENT SURVEY MARKERS, TYPE I	EACH	3	3		
67000400	ENGINEER'S FIELD OFFICE, TYPE A	CAL MO	6	6		
67100100	MOBILIZATION	L SUM	1	1		
70100405	TRAFFIC CONTROL AND PROTECTION, STANDARD 701321	EACH	2		2	
70100450	TRAFFIC CONTROL AND PROTECTION, STANDARD 701201	L SUM	1	1		
70100460	TRAFFIC CONTROL AND PROTECTION, STANDARD 701306	L SUM	1	1		
70106500	TEMPORARY BRIDGE TRAFFIC SIGNALS	EACH	2		2	
70107005	PAVEMENT MARKING BLACKOUT TAPE, 5"	FOOT	2024		2024	
70107025	CHANGEABLE MESSAGE SIGN	CAL DA	28	28		

SUMMARY OF QUANTITIES			TOTAL QUANTITIES	CONSTRUCTION TYPE CODE		
CODE NO	ITEM	UNIT		0005	0004	0047
70300100	SHORT TERM PAVEMENT MARKING	FOOT	16974	16974		
70300150	SHORT TERM PAVEMENT MARKING REMOVAL	SQ FT	1886	1886		
70300220	TEMPORARY PAVEMENT MARKING - LINE 4"	FOOT	134253	134253		
70400100	TEMPORARY CONCRETE BARRIER	FOOT	938		938	
70400200	RELOCATE TEMPORARY CONCRETE BARRIER	FOOT	938		938	
70600250	IMPACT ATTENUATORS, TEMPORARY (NON- REDIRECTIVE), TEST LEVEL 3	EACH	4		4	
70600350	IMPACT ATTENUATORS, RELOCATE (NON- REDIRECTIVE), TEST LEVEL 3	EACH	4		4	
* 78001110	PAINT PAVEMENT MARKING - LINE 4"	FOOT	134253	134253		
* 78100100	RAISED REFLECTIVE PAVEMENT MARKER	EACH	708	708		
X0326440	SURFACE REMOVAL, VARIABLE DEPTH (SPECIAL)	SQ YD	4525	4525		
X4401198	HOT-MIX ASPHALT SURFACE REMOVAL, VARIABLE DEPTH	SQ YD	268	268		
Z0001495	BRIDGE APPROACH SHOULDER REMOVAL	SQ YD	18		18	

* SPECIALTY ITEM

MODEL: Default
FILE: Model - Publications\room.dwg
PROJECT: 74945\CAAD\Drawings\DOT - Office\Drawings\74945\Site\500.dgn

USER NAME = steffenmk	DESIGNED -	REVISED -
PLOT SCALE = 100.0000' / in.	DRAWN -	REVISED -
PLOT DATE = 12/17/2020	CHECKED -	REVISED -
	DATE -	REVISED -

STATE OF ILLINOIS
DEPARTMENT OF TRANSPORTATION

SUMMARY OF QUANTITIES

SCALE: SHEET 2 OF 3 SHEETS STA. TO STA.

F.A.P. RTE. 832	SECTION (113.114)RS-4	COUNTY CLARK	TOTAL SHEETS 46	SHEET NO. 4
CONTRACT NO. 74945			ILLINOIS FED. AID PROJECT	

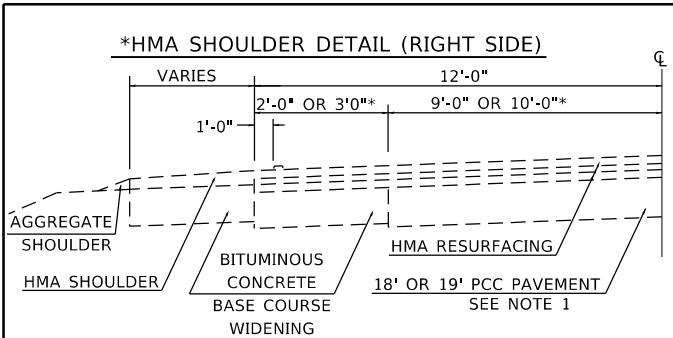

① EXISTING TYPICAL CROSS SECTION ①

STATION	TO	STATION	STATION	TO	STATION
① 90+82		126+10 ②	③ 506+57		588+26 ②
② 157+95		213+71 ③	STATION EQUATION: 574+75 BK = 575+25 AH		
③ 234+84		318+20 ②	② 598+42		602+44 ④
② 334+47		455+20 ②	④ 612+26		633+34 ③
② 469+35		483+00 ④	STATION EQUATION: 615+02 BK = 614+52 AH		
④ 492+94		496+62 ③	③ 643+16		656+61

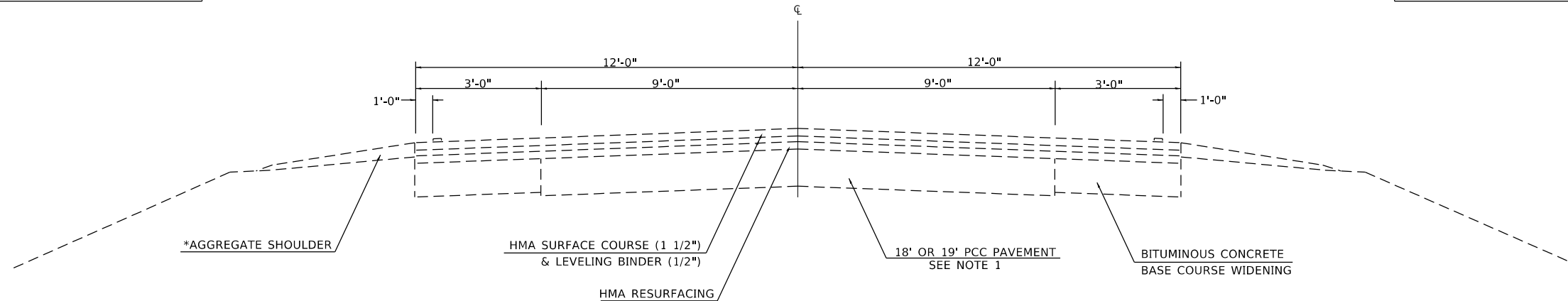
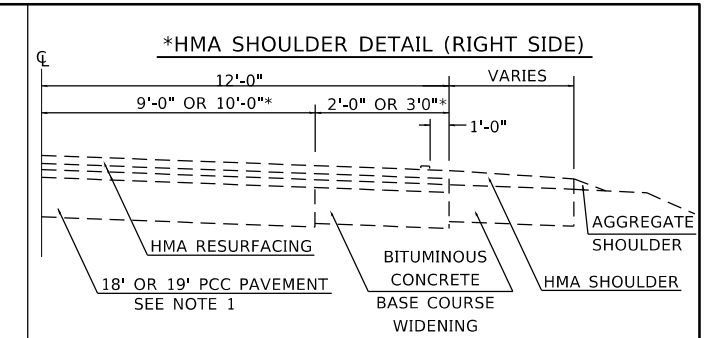

*HMA SHOULDERS (SEE DETAIL)

	STA	TO	STA	WIDTH
RT	492+94		494+75	3'
LT	495+85		496+62	3'
LT	506+57		507+85	3'
LT/RT	580+94		588+26	2'
LT/RT	598+42		601+00	2'
RT	601+00		602+44	3'

NOTES:
1. VARIOUS SECTIONS THROUGHOUT THIS PROJECT WERE ORIGINALLY BUILT WITH A 19' PCC BASE. AN 18' PCC BASE IS SHOWN ON ALL TYPICALS.

NOTE: NOT DRAWN TO SCALE

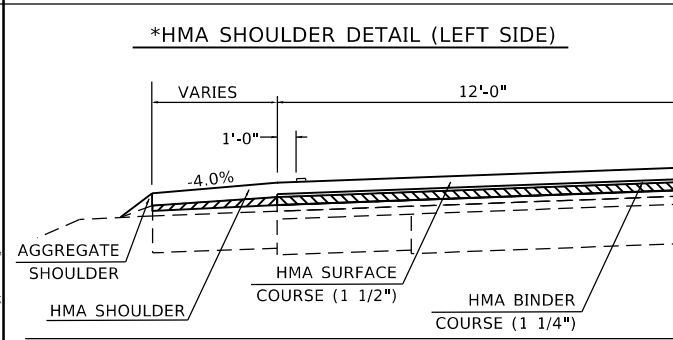

① PROPOSED TYPICAL CROSS SECTION ①

STATION	TO	STATION	STATION	TO	STATION
① 90+82		126+10 ②	③ 506+57		588+26 ②
② 157+95		213+71 ③	STATION EQUATION: 574+75 BK = 575+25 AH		
③ 234+84		318+20 ②	② 598+42		602+44 ④
② 334+47		455+20 ②	④ 612+26		633+34 ③
② 469+35		483+00 ④	STATION EQUATION: 615+02 BK = 614+52 AH		
④ 492+94		496+62 ③	③ 643+16		656+61

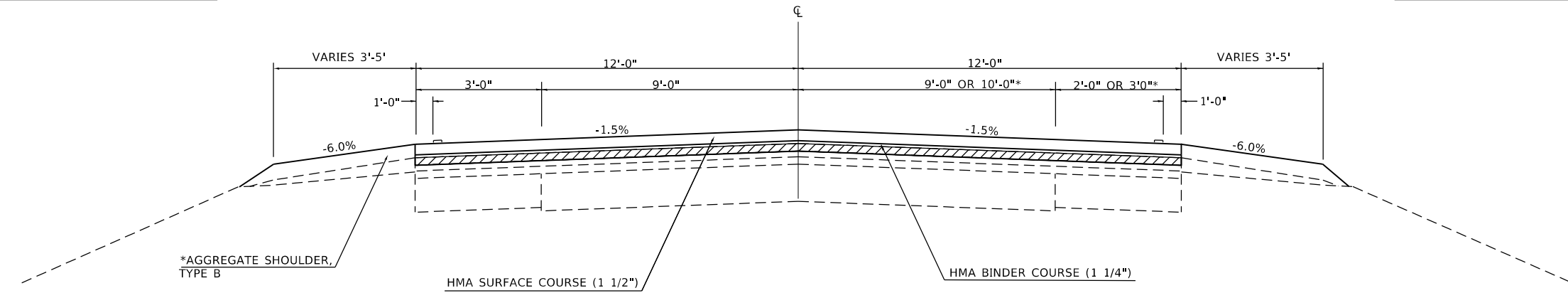
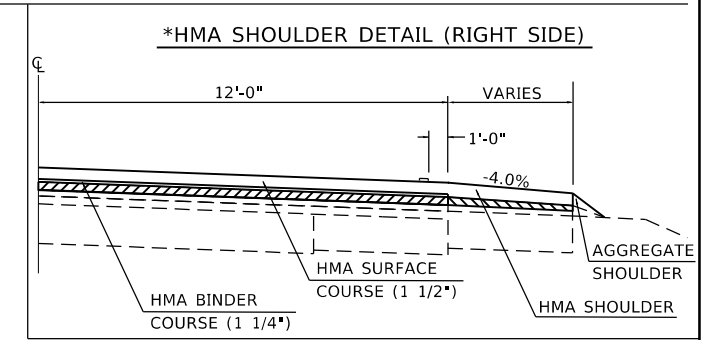

*HMA SHOULDERS (SEE DETAIL)

	STA	TO	STA	WIDTH
RT	492+94		494+75	3'
LT	495+85		496+62	3'
LT	506+57		507+85	3'
LT/RT	580+94		588+26	2'
LT/RT	598+42		601+00	2'
RT	601+00		602+44	3'

HOT-MIX ASPHALT SURFACE REMOVAL, 1 1/2"

NOTE: NOT DRAWN TO SCALE

MODEL: Default
FILE: \\s:\pub\baronm.d\at\illinois.gov\PROJECTS\DOT\Documents\DOT_Offices\Illinois\74945\Sheet\typical.dgn

USER NAME = steffnmk	DESIGNED -	REVISED -
	DRAWN -	REVISED -
PLOT SCALE = 100.0000' / in.	CHECKED -	REVISED -
PLOT DATE = 12/17/2020	DATE -	REVISED -

STATE OF ILLINOIS
DEPARTMENT OF TRANSPORTATION

TYPICAL CROSS SECTIONS

SCALE: SHEET 1 OF 4 SHEETS STA. TO STA.

F.A.P. RTE.	SECTION	COUNTY	TOTAL SHEETS	SHEET NO.
832	(113,114)RS-4	CLARK	46	6
CONTRACT NO. 74945				
ILLINOIS		FED. AID PROJECT		

*HMA SHOULDER DETAIL (LEFT SIDE)

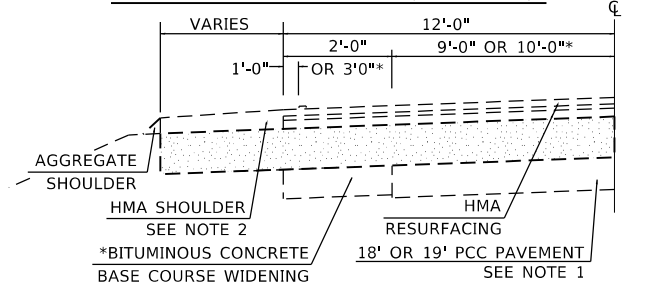

② EXISTING TYPICAL CROSS SECTION ②

STATION	TO	STATION
① 126+10		157+95 ①
① 318+20		334+47 ①
① 455+20		469+35 ①
① 588+26		598+42 ①

PAVING OMISSION: 593+96 TO 595+16

*HMA SHOULDER DETAIL (RIGHT SIDE)

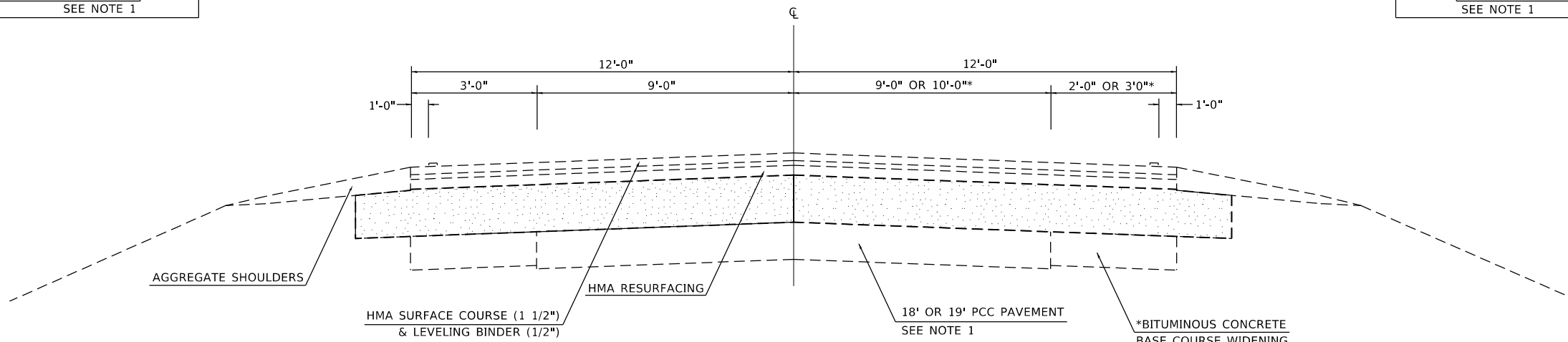
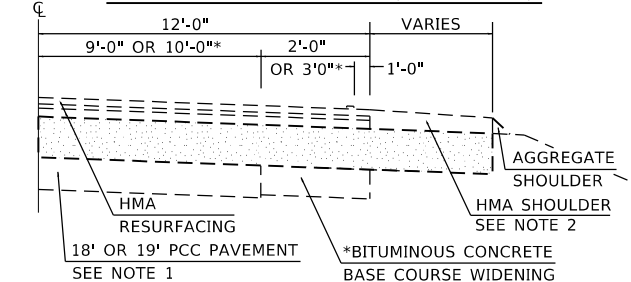

*HMA SHOULDERS (SEE DETAIL)

	STA	TO	STA	WIDTH
LT/RT	588+26		589+94	2'
LT/RT	591+67		593+66	4'
LT/RT	595+46		597+41	4.5'
LT/RT	597+41		598+42	2'

*NO BITUMINOUS BASE COURSE WIDENING

STATION	TO	STATION
129+33		154+70
321+15		333+67
456+47		466+90
589+18		597+41

NOTES:
 1. VARIOUS SECTIONS THROUGHOUT THIS PROJECT WERE ORIGINALLY BUILT WITH A 19' PCC BASE. FOR SIMPLICITY, AN 18' PCC BASE IS SHOWN ON ALL TYPICALS.
 2. IT IS UNKNOWN WHAT TYPE OF BASE IS UNDER THE EXISTING HMA SHOULDERS. GRANULAR EMBANKMENT IS SHOWN IN THIS TYPICAL.
 NOTE: NOT DRAWN TO SCALE

*HMA SHOULDER DETAIL (LEFT SIDE)

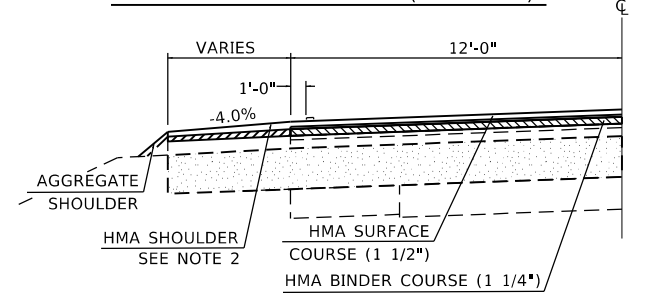

② PROPOSED TYPICAL CROSS SECTION ②

STATION	TO	STATION
① 126+10		157+95 ①
① 318+20		334+47 ①
① 455+20		469+35 ①
① 588+26		598+42 ①

PAVING OMISSION: 593+96 TO 595+16

*HMA SHOULDER DETAIL (RIGHT SIDE)

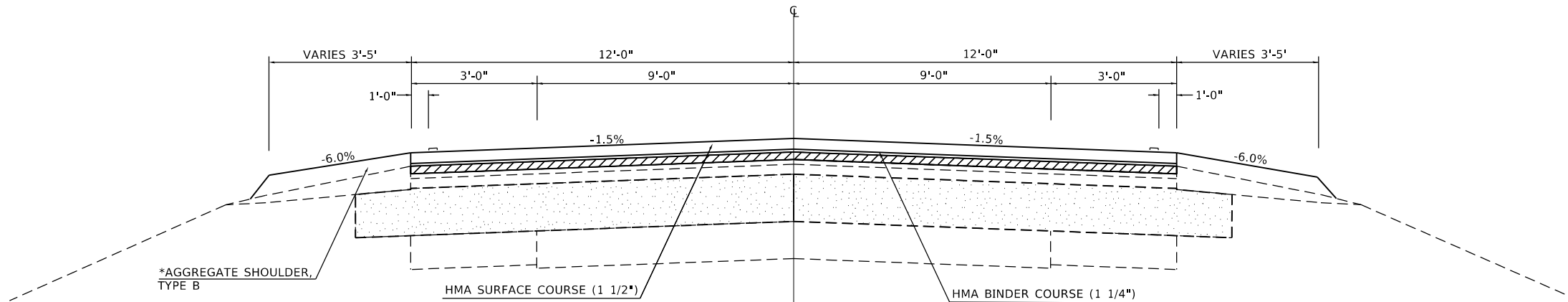
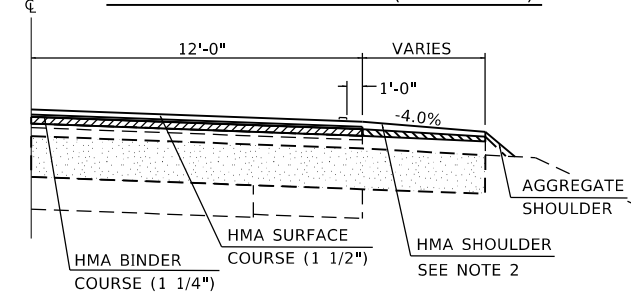

*HMA SHOULDERS (SEE DETAIL)

	STA	TO	STA	WIDTH
LT/RT	588+26		589+94	2'
LT/RT	591+67		593+66	4'
LT/RT	595+46		597+41	4.5'
LT/RT	597+41		598+42	2'

*NO BITUMINOUS BASE COURSE WIDENING

STATION	TO	STATION
129+33		154+70
321+15		333+67
456+47		466+90
589+18		597+41

NOTES:
 1. VARIOUS SECTIONS THROUGHOUT THIS PROJECT WERE ORIGINALLY BUILT WITH A 19' PCC BASE. FOR SIMPLICITY, AN 18' PCC BASE IS SHOWN ON ALL TYPICALS.
 2. IT IS UNKNOWN WHAT TYPE OF BASE IS UNDER THE EXISTING HMA SHOULDERS. GRANULAR EMBANKMENT IS SHOWN IN THIS TYPICAL.

HOT-MIX ASPHALT SURFACE REMOVAL, 1 1/2" NOTE: NOT DRAWN TO SCALE

MODEL: Default
 FILE: \\p:\pub\baron\ada\illinois\pwr\DOT\Documents\DOT_Offices\Illinet 7\Projects\74945\CADD\Drawings\74945-shc\typical.dgn

USER NAME = steffemk	DESIGNED -	REVISED -
	DRAWN -	REVISED -
PLOT SCALE = 100.0000' / in.	CHECKED -	REVISED -
PLOT DATE = 12/17/2020	DATE -	REVISED -

**STATE OF ILLINOIS
DEPARTMENT OF TRANSPORTATION**

TYPICAL CROSS SECTIONS

SCALE: SHEET 2 OF 4 SHEETS STA. TO STA.

F.A.P. RTE.	SECTION	COUNTY	TOTAL SHEETS	SHEET NO.
832	(113,114)RS-4	CLARK	46	7
CONTRACT NO. 74945				
ILLINOIS		FED. AID PROJECT		

③ EXISTING TYPICAL CROSS SECTION ③

STATION	TO	STATION
① 213+71		224+27 ④
① 496+62		506+57 ①
PAVING OMISSION: 502+81 TO 503+93		
① 633+34		643+16 ①

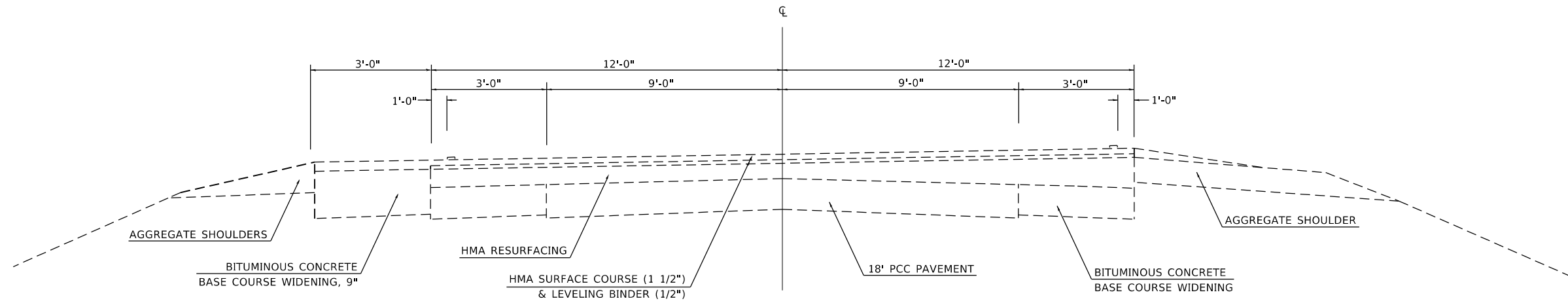

SUPER-ELEVATION RATES			
STATION	TO	STATION	SUPER-ELEVATION
213+71	234+84		= 2.1% (NB) and 2.1% (SB)
496+62	506+57		= 2.3% (NB) and 3.1% (SB)
633+34	643+16		= 7.3% (NB) and 8.3% (SB)

NOTE: NOT DRAWN TO SCALE

③ PROPOSED TYPICAL CROSS SECTION ③

STATION	TO	STATION
① 213+71		224+27 ④
① 496+62		506+57 ①
PAVING OMISSION: 502+81 TO 503+93		
① 633+34		643+16 ①

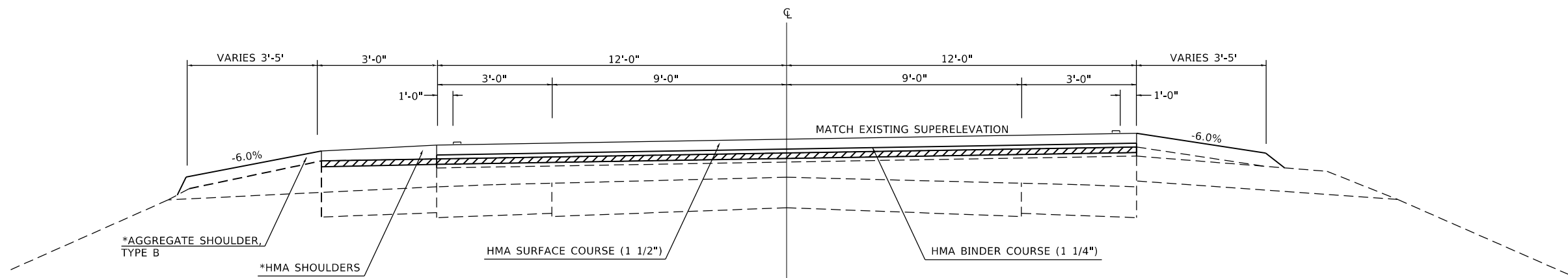

SUPER-ELEVATION RATES			
STATION	TO	STATION	SUPER-ELEVATION
213+71	234+84		= 2.1% (NB) and 2.1% (SB)
496+62	506+57		= 2.3% (NB) and 3.1% (SB)
633+34	643+16		= 7.3% (NB) and 8.3% (SB)

 HOT-MIX ASPHALT SURFACE REMOVAL, 1 1/2"

NOTE: NOT DRAWN TO SCALE

*AGGREGATE SHOULDER (NO HMA LEFT SIDE)
 STATION TO STATION
 213+71 224+27

MODEL: Default
 FILE: \\nas01c.psu.edu\pub\harcourt\illinois\gov\RWIDOT\Documents\DOT_Offices\District 7\Projects\74945\CADD\Drawings\74945-shct-typical.dgn

USER NAME = steffemk	DESIGNED -	REVISED -	
	DRAWN -	REVISED -	
PLOT SCALE = 100.0000' / in.	CHECKED -	REVISED -	
PLOT DATE = 12/17/2020	DATE -	REVISED -	

**STATE OF ILLINOIS
DEPARTMENT OF TRANSPORTATION**

TYPICAL CROSS SECTIONS

SCALE: SHEET 3 OF 4 SHEETS STA. TO STA.

F.A.P. RTE.	SECTION	COUNTY	TOTAL SHEETS	SHEET NO.
832	(113.114)RS-4	CLARK	46	8
CONTRACT NO. 74945				
ILLINOIS FED. AID PROJECT				

④ EXISTING TYPICAL CROSS SECTION ④

STATION	TO	STATION
③ 224+27		234+84 ①
① 483+00		492+94 ①
① 602+44		612+26 ①

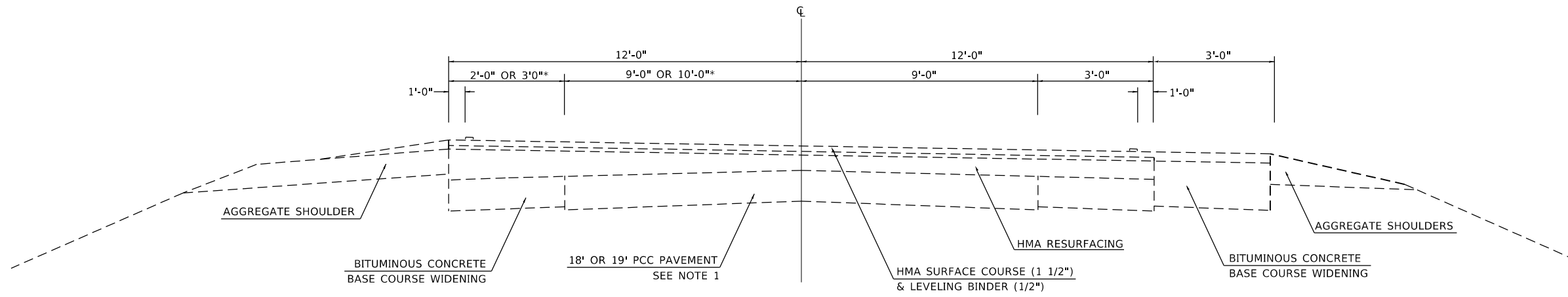

SUPER-ELEVATION RATES

STATION	TO	STATION	SUPER-ELEVATION
224+27		234+84	= 2.1% (NB) and 1.8% (SB)
483+00		492+94	= 4.0% (NB) and 3.0% (SB)
602+44		612+26	= 6.4% (NB) and 6.0% (SB)

NOTES:
1. VARIOUS SECTIONS THROUGHOUT THIS PROJECT WERE ORIGINALLY BUILT WITH A 19' PCC BASE. AN 18' PCC BASE IS SHOWN ON ALL TYPICALS.

NOTE: NOT DRAWN TO SCALE

④ PROPOSED TYPICAL CROSS SECTION ④

STATION	TO	STATION
③ 224+27		234+84 ①
① 483+00		492+94 ①
① 602+44		612+26 ①

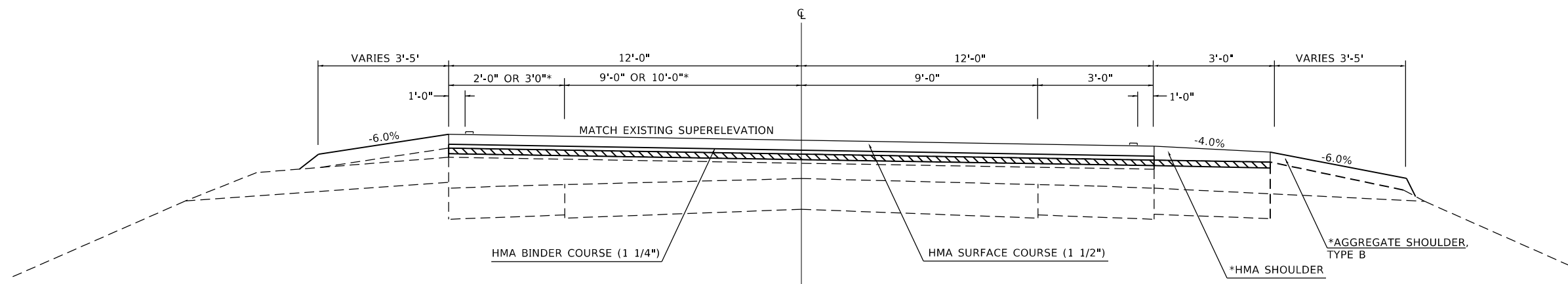

SUPER-ELEVATION RATES

STATION	TO	STATION	SUPER-ELEVATION
224+27		234+84	= 2.1% (NB) and 1.8% (SB)
483+00		492+94	= 4.0% (NB) and 3.0% (SB)
602+44		612+26	= 6.4% (NB) and 6.0% (SB)

*AGGREGATE SHOULDER (NO HMA RIGHT SIDE)
STATION TO STATION
224+27 234+84

HOT-MIX ASPHALT SURFACE REMOVAL, 1 1/2"

NOTE: NOT DRAWN TO SCALE

MODEL: Default
FILE: Model_Cross_Section.dgn
PROJECT: 74945-CAADDataCADsheets\DOT_74945-Subtypical.dgn

USER NAME = steffenmk	DESIGNED -	REVISED -
	DRAWN -	REVISED -
PLOT SCALE = 100.0000' / in.	CHECKED -	REVISED -
PLOT DATE = 12/17/2020	DATE -	REVISED -

**STATE OF ILLINOIS
DEPARTMENT OF TRANSPORTATION**

TYPICAL CROSS SECTIONS

SCALE: SHEET 4 OF 4 SHEETS STA. TO STA.

F.A.P. RTE.	SECTION	COUNTY	TOTAL SHEETS	SHEET NO.
832	(113.114)RS-4	CLARK	46	9
CONTRACT NO. 74945				
ILLINOIS FED. AID PROJECT				

SCHEDULE OF QUANTITIES

HOT-MIX ASPHALT

STATION	TO	STATION	LENGTH (FOOT)	BINDER COURSE THICKNESS (INCH)	SURFACE COURSE THICKNESS (INCH)	WIDTH (FOOT)	AREA (SQ YD)	BITUMINOUS MATERIALS (TACK COAT) (POUNDS)	HOT-MIX ASPHALT BINDER COURSE, IL-9.5FG, N70 (TONS)	HOT-MIX ASPHALT SURFACE COURSE, IL-9.5, MIX "C", N70 (TONS)
90+82		90+92	10		1.5	24	27	12		2
90+92		91+07	15	0.63	1.5	24	40	27	1	3
91+07		502+76	41,169	1.25	1.5	24	109,784	74,104	7,685	9,222
502+76		502+81	5	1.38	1.5	24	13	9	1	1
BRIDGE OMISSION										
503+93		503+98	5	1.38	1.5	24	13	9	1	1
503+98		593+61	8,963	1.25	1.5	24	23,901	16,133	1,673	2,008
593+61		593+66	5	1.38	1.5	24	13	9	1	1
593+66		593+96	30		1.5	24	80	36		7
BRIDGE OMISSION										
595+16		595+46	30		1.5	24	80	36		7
595+46		595+51	5	1.38	1.5	24	13	9	1	2
595+51		656+36	6,085	1.25	1.5	24	16,227	10,953	1,136	1,363
656+36		656+51	15	0.63	1.5	24	40	27	1	3
656+51		656+61	10		1.5	24	27	12		2
495+85	LT	502+81	LT	696	1.25	1.5	3	232	157	16
BRIDGE OMISSION										
503+83	LT	507+85	LT	402	1.25	1.5	3	134	90	9
580+94	LT	589+94	LT	900	1.25	1.5	2	200	135	14
591+67	LT	593+66	LT	199	1.25	1.5	4	88	59	6
BRIDGE OMISSION										
595+46	LT	597+41	LT	195	1.25	1.5	4.5	98	66	7
597+41	LT	601+00	LT	359	1.25	1.5	2	80	54	6
633+34	LT	643+16	LT	982	1.25	1.5	3	327	221	23
483+00	RT	494+75	RT	1,175	1.25	1.5	3	392	265	27
500+50	RT	502+76	RT	226	1.25	1.5	3	75	51	5
502+76	RT	502+91	RT	15	1.38	1.5	3	5	3	1
BRIDGE OMISSION										
503+83	RT	503+98	RT	15	1.38	1.5	3	5	3	1
503+98	RT	506+50	RT	252	1.25	1.5	3	84	57	6
580+94	RT	589+94	RT	900	1.25	1.5	2	200	135	14
591+67	RT	593+66	RT	199	1.25	1.5	4	88	59	6
BRIDGE OMISSION										
595+46	RT	597+41	RT	195	1.25	1.5	4.5	98	66	7
597+41	RT	602+44	RT	503	1.25	1.5	2	112	76	8
602+44	RT	612+26	RT	982	1.25	1.5	3	327	221	23
TOTAL								103,094	10,679	12,834

BRIDGE APPROACH

STATION	TO	STATION	LENGTH (FOOT)	MAINLINE WIDTH (FOOT)	SHOULDER WIDTH (FOOT)	PAVEMENT CONNECTOR (HMA) FOR BRIDGE APPROACH SLAB (SQ YD)	BRIDGE APPROACH SHOULDER REMOVAL (SQ YD)	APPROACH SLAB REMOVAL (SQ YD)
50281		50291	10	32		35.56		
50291		50311	20	24	8		17.78	53.33
50353		50363	10	32		35.56		
50363		50383	20	24	8		17.78	53.33
TOTAL =						70	36	107

AGGREGATE SHOULDERS

STATION	TO	STATION	LENGTH (FOOT)	PRA/ENT DEDUCT LENGTH (FOOT)	WIDTH (FOOT)	AREA (SQ YD)	AGGREGATE SHOULDER, TYPE B (TONS)
90+82	LT	336+63	LT	24,581	731	5	13,250
336+63	LT	455+20	LT	11,857	625	4	4,992
455+20	LT	456+47	LT	127		5	71
456+47	LT	469+35	LT	1,288	32	4	558
469+35	LT	482+97	LT	1,362	30	4	592
482+97	LT	495+11	LT	1,214	265	4	422
495+11	LT	502+91	LT	780		1	87
BRIDGE OMISSION							
503+83	LT	507+85	LT	402		1	45
507+85	LT	580+94	LT	7,309	633	4	2,967
580+94	LT	589+94	LT	900	35	1	96
589+94	LT	591+67	LT	173		2	38
BRIDGE OMISSION							
595+46	LT	612+26	LT	1,680	110	1	174
612+26	LT	633+34	LT	2,108	32	4	923
633+34	LT	643+16	LT	982		1	109
643+16	LT	656+61	LT	1,345	95	4	556
LT TOTAL =				56,108	2,588		2,775
BRIDGE OMISSION							
90+82	RT	336+63	RT	24,581	1,223	5	12,977
336+63	RT	455+20	RT	11,857	418	4	5,084
455+20	RT	456+47	RT	127	64	5	35
456+47	RT	469+35	RT	1,288	99	4	528
469+35	RT	482+97	RT	1,362	92	4	564
482+97	RT	495+11	RT	1,214	68	1	127
495+11	RT	500+50	RT	539	38	4	223
500+50	RT	502+91	RT	241		1	27
BRIDGE OMISSION							
503+83	RT	506+50	RT	267		1	30
506+50	RT	507+85	RT	135		4	60
507+85	RT	580+94	RT	7,309	363	4	3,087
580+94	RT	589+94	RT	900	30	1	97
589+94	RT	591+67	RT	173		2	38
BRIDGE OMISSION							
595+46	RT	612+26	RT	1,680	32	1	183
612+26	RT	633+34	RT	2,108	64	4	908
633+34	RT	643+16	RT	982	84	2	200
643+16	RT	656+61	RT	1,345	86	4	560
RT TOTAL =				56,108	2,661		2,760
TOTAL							5,535

HMA SHOULDERS

STATION	TO	STATION	WIDTH (FOOT)	LENGTH (FOOT)	AREA (SQ YD)	UNITS	EXCAVATING AND GRADING EXISTING SHOULDER (UNITS)	HOT-MIX ASPHALT SHOULDERS, 10" (SQ YD)
500+50	RT	502+91	RT	3.0	241.0	80.3	2.4	80.3
503+83	RT	506+50	RT	3.0	267.0	89.0	2.7	89.0
TOTAL =							5.1	169.3
ROUND TO:							6.0	170.0

MODEL: Default
 FILE: hma_sch.pwd\DOT\Documents\DOT - Office\Drawings\79495\hmc-schedule.dgn
 PROJECT: 79495\CAD\DATA\CAD\hmc-schedule.dgn

USER NAME = steffemk	DESIGNED -	REVISED -
	DRAWN -	REVISED -
PLOT SCALE = 100.0000' / in.	CHECKED -	REVISED -
PLOT DATE = 12/17/2020	DATE -	REVISED -

**STATE OF ILLINOIS
DEPARTMENT OF TRANSPORTATION**

SCHEDULE OF QUANTITIES

SCALE: SHEET 2 OF 4 SHEETS STA. TO STA.

F.A.P. RTE. 832	SECTION (113,114)RS-4	COUNTY CLARK	TOTAL SHEETS 46	SHEET NO. 11
CONTRACT NO. 74945				
ILLINOIS		FED. AID PROJECT		

SCHEDULE OF QUANTITIES

ENTRANCES

SIDE	STATION	TYPE	SURFACE REMOVAL, VARIABLE DEPTH (SPECIAL) (SQ YD)	INCIDENTAL HOT-MIX ASPHALT SURFACING (TON)	AGGREGATE SURFACE COURSE, TYPE B (TON)	LENGTH (FOOT)
RT	96+02	PRA	41	5		10
LT	96+02	PRA	37	4		10
RT	109+65	FE	23	3		10
RT	122+95	PRA	41	5		10
LT	122+95	PRA	41	5		10
RT	156+00	FE	30	4		10
LT	156+00	FE	26	3		10
LT	162+75	FE	39	5		10
RT	176+50	PRA	39	5		10
LT	176+50	PRA	39	5		10
LT	189+90	CE	31	4		10
RT	189+98	FE	69	8		10
LT	191+70	CE	73	9		10
RT	196+18	FE			3	10
RT	200+11	CE	49	6		10
RT	202+69	PE	29	3		10
LT	204+70	FE	24	3		10
RT	209+20	FE	32	4		10
LT	216+30	PRA	36	4		10
RT	216+50	FE	23	3		10
RT	236+95	FE	26	3		10
RT	242+96	PRA	62	7		10
LT	243+10	PRA	48	6		10
RT	245+80	FE	28	3		10
RT	253+95	FE	37	4		10
LT	261+61	FE	33	4		10
RT	269+35	FE	26	3		10
LT	269+77	FE	33	4		10
RT	272+94	FE	35	4		10
RT	287+60	FE	34	4		10
RT	296+02	FE	31	4		10
LT	296+02	FE	30	4		10
LT	300+20	PE			4	10
LT	305+20	PE	30	4		10
RT	309+28	FE	31	4		10
RT	322+47	PE	34	4		10
LT	325+32	FE	22	3		10
RT	325+45	PE	59	7		10
RT	329+00	CE	36	4		10
RT	329+77	CE	61	7		10
RT	331+66	CE	61	7		10
RT	332+34	PE	34	4		10
RT	333+78	PE	69	8		10
LT	334+00	FE	39	5		10
RT	336+05	PRA	56	7		10
LT	336+20	PRA	48	6	4	10
RT	349+38	PE	28	3		10
LT	349+38	FE	30	4	2	10
LT	350+32	FE	24	3		10

SIDE	STATION	TYPE	SURFACE REMOVAL, VARIABLE DEPTH (SPECIAL) (SQ YD)	INCIDENTAL HOT-MIX ASPHALT SURFACING (TON)	AGGREGATE SURFACE COURSE, TYPE B (TON)	LENGTH (FOOT)
LT	362+42	FE	39	5		10
LT	367+68	FE	42	5		10
RT	367+73	PE	69	8		10
LT	389+00	PRA	41	5		10
RT	389+12	PRA	43	5		10
LT	390+85	FE	31	4		10
LT	402+40	FE	23	3		10
RT	404+50	FE	29	3		10
LT	404+53	FE	29	3		10
LT	407+15	FE	30	4		10
LT	407+81	FE	30	4		10
LT	411+73	FE	28	3		10
RT	412+41	FE	31	4		10
LT	421+33	PE	33	4		10
RT	424+79	FE			3	10
RT	426+05	FE	29	3		10
RT	428+78	FE			2	10
LT	428+78	PRA	31	4		10
LT	430+02	FE	21	2		10
RT	438+75	PE	31	4		10
RT	442+11	PE	48	6	2	10
LT	442+11	PE	27	3		10
LT	444+43	PE	34	4		10
LT	446+39	FE	50	6		10
RT	451+72	FE	20	2		10
LT	451+86	FE	29	3		10
RT	453+27	FE	32	4		10
RT	456+06	FE	26	3		10
RT	456+46		29	3		10
RT	457+35	FE	30	4		10
LT	459+54	PE	30	4		10
RT	463+55	FE	31	4		10
RT	469+11	FE	28	3		10
RT	469+69	FE	28	3		10
RT	472+64	PE	38	5		10
LT	474+92	FE	29	3		10
RT	481+74	FE	21	2		10
LT	490+40	PE	44	5		10
LT	495+06	PRA	134	16		10
RT	495+11	PRA	52	6		10
RT	498+35	FE	32	4	2	10
RT	501+35	FE			3	10
LT	501+80	FE			3	10
LT	505+41	FE			3	10
RT	509+79	FE	32	4		10
LT	509+86	FE	23	3		10
LT	521+48	FE	27	3		10
RT	521+51	FE	24	3		10
LT	528+11	PE	84	10		10

SIDE	STATION	TYPE	SURFACE REMOVAL, VARIABLE DEPTH (SPECIAL) (SQ YD)	INCIDENTAL HOT-MIX ASPHALT SURFACING (TON)	AGGREGATE SURFACE COURSE, TYPE B (TON)	LENGTH (FOOT)
LT	535+10	FE	29	3		10
RT	548+00	PRA	36	4		10
LT	548+00	PRA	42	5		10
LT	554+21	PE	24	3		10
LT	556+07	PE			2	10
LT	561+54	CE	56	7		10
LT	561+91	CE	50	6		10
RT	562+96	PRA	133	16		10
LT	562+96	PRA	106	13		10
RT	567+41	FE	28	3		10
LT	568+92	PE	53	6		10
RT	574+56	PRA	23	3		10
LT	574+56	PRA	47	6		10
LT	585+78	PE	36	4		10
RT	589+27	FE	27	3		10
RT	600+11	FE	29	3		10
LT	601+24	PE	32	4		10
LT	602+84	PE	38	5		10
LT	610+59	FE	26	3		10
LT	619+46	FE	29	3		10
LT	624+19	PE			5	10
RT	629+68	PE	31	4		10
RT	632+50	PE	31	4		10
RT	636+32	PRA	58	7		10
LT	646+49	FE	33	4		10
RT	655+95	FE	20	2		10
RT	656+61	PRA	58	7		10
LT	656+61	PRA	51	6		10
TOTAL			4525	541	38	

MODEL: Default
 FILE: \\s:\p\pub\baronm.dwg
 PROJECT: 74945\CA00\Drawings\DOT - Office\Drawings\74945-Sub-Schedule.dwg

USER NAME = steffenmk	DESIGNED -	REVISED -
	DRAWN -	REVISED -
PLOT SCALE = 100.0000 ' / in.	CHECKED -	REVISED -
PLOT DATE = 12/17/2020	DATE -	REVISED -

STATE OF ILLINOIS
DEPARTMENT OF TRANSPORTATION

SCHEDULE OF QUANTITIES

SCALE: SHEET 3 OF 4 SHEETS STA. TO STA.

F.A.P. RTE.	SECTION	COUNTY	TOTAL SHEETS	SHEET NO.
832	(113,114)RS-4	CLARK	46	12
CONTRACT NO. 74945				
ILLINOIS FED. AID PROJECT				

SCHEDULE OF QUANTITIES

TEMPORARY AND PAINT PAVEMENT MARKING LINE

TEMPORARY AND PAINT PAVEMENT MARKING - LINE 4"										
STATION	TO	STATION	LENGTH	PRA DEDUCT	WHITE	YELLOW - SKIP DASH	YELLOW - NO PASSING ZONE	YELLOW - DOUBLE NO PASSING ZONE	YELLOW TOTAL	TOTAL
90+82		94+49	367	0	734	92	367		459	1193
94+49		331+33	23684	499	46869	5921			5921	52790
331+33		350+37	1904	135	3673	476	1904		2380	6053
350+37		353+70	333	0	666	83			83	749
353+70		365+85	1215	0	2430	304	1215		1519	3949
365+85		516+66	15081	503	29659	3770			3770	33429
516+66		526+87	1021	0	2042	255	1021		1276	3318
526+87		528+15	128	0	256			256	256	512
528+15		537+30	915	0	1830	229	915		1144	2974
537+30		592+82	5552	546	10558	1388			1388	11946
592+82		606+62	1380	0	2760	345	1380		1725	4485
606+62		612+02	540	0	1080			1080	1080	2160
612+02		620+72	870	0	1740	218	870		1088	2828
620+72		656+61	3589	208	6970	897			897	7867
TOTAL			56579	1891	111267	13978	7672	1336	22986	134253

SHORT TERM PAVEMENT MARKING

STATION	TO	STATION	LENGTH	SHORT TERM PAVEMENT MARKING (FOOT)	SHORT TERM PAVEMENT MARKING REMOVAL (SQ FT)	RAISED REFLECTIVE PAVEMENT MARKER (EACH)
90+82		656+61	56579	16974	1886	708
TOTAL =				16974	1886	708

PAVEMENT MARKING BLACKOUT TAPE

PAVEMENT MARKING BLACKOUT TAPE, 5"						
S.N. 012-0061						
		LENGTH	LT EDGELINE LENGTH	CENTERLINE LENGTH	RT EDGELINE LENGTH	FOOT
501+56		505+19	363			363
499+04		507+17	813	204		204
501+42		505+45	403		403	403
S.N. 012-0061 TOTAL:						970
S.N. 012-0066						
592+49		596+63	414	414		414
590+28		598+85	857	215		215
592+44		596+69	425		425	425
S.N. 012-0066 TOTAL:						1054

TEMPORARY CONCRETE BARRIER

TEMPORARY CONCRETE BARRIER (STAGE 1) AND TEMPORARY CONCRETE BARRIER (STAGE 2)		RELOCATE
S.N. 012-0061:		
SOUTH TAPER LENGTH:	139.2 FEET	(11 BARRIER SECTIONS)
LENGTH OF TANGENT SECTION:	189.7 FEET	(15 BARRIER SECTIONS)
NORTH TAPER LENGTH:	151.9 FEET	(12 BARRIER SECTIONS)
012-0061 TOTAL =	480.8 FEET	
ROUND TO:	481.0 FEET	
S.N. 012-0066:		
SOUTH TAPER LENGTH:	101.2 FEET	(8 BARRIER SECTIONS)
LENGTH OF TANGENT SECTION:	241.2 FEET	(19 BARRIER SECTIONS)
NORTH TAPER LENGTH:	113.9 FEET	(9 BARRIER SECTIONS)
012-0061 TOTAL =	456.3 FEET	
ROUND TO:	457.0 FEET	
GRAND TOTAL =		938.0 FEET

GUARDRAIL

LOCATION	S.N.	REMOVE AND REERECT STEEL PLATE BEAM GUARDRAIL, TYPE A (FOOT)	REMOVE AND REERECT TRAFFIC BARRIER TERMINAL, TYPE 6 (EACH)
012-0061			
NW QUADRANT		25	1
NE QUADRANT		25	1
SW QUADRANT		25	1
SE QUADRANT		25	1
TOTAL =		100	4

MODEL: Default
 FILE: Model: P:\pub\harcourt\dot\Documents\DOT_Offices\Drawings\74945\CADD\Drawings\DOT_74945-SHS-Schedule.dgn

USER NAME = steffenmk	DESIGNED -	REVISED -
	DRAWN -	REVISED -
PLOT SCALE = 100.0000' / in.	CHECKED -	REVISED -
PLOT DATE = 12/17/2020	DATE -	REVISED -

**STATE OF ILLINOIS
DEPARTMENT OF TRANSPORTATION**

SCHEDULE OF QUANTITIES			
SCALE:	SHEET 4	OF 4 SHEETS	STA. TO STA.

F.A.P. RTE.	SECTION	COUNTY	TOTAL SHEETS	SHEET NO.
832	(113,114)RS-4	CLARK	46	13
CONTRACT NO. 74945				
ILLINOIS		FED. AID PROJECT		

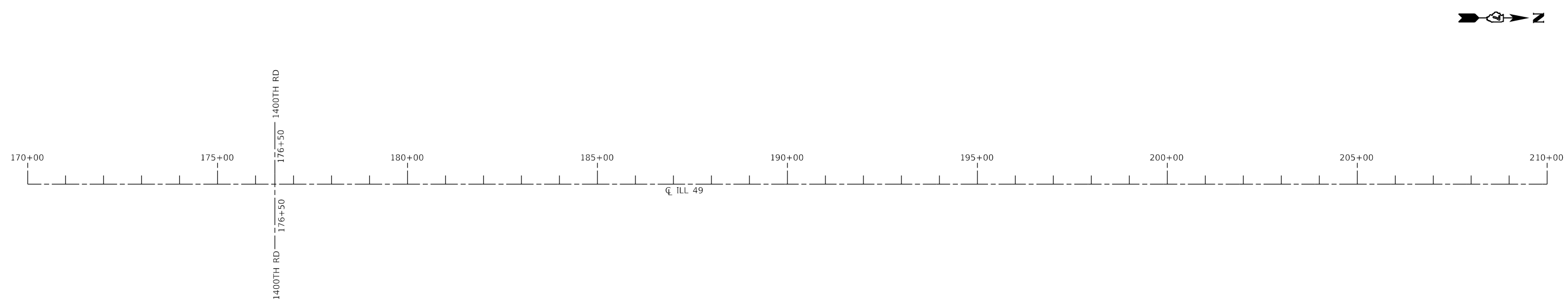
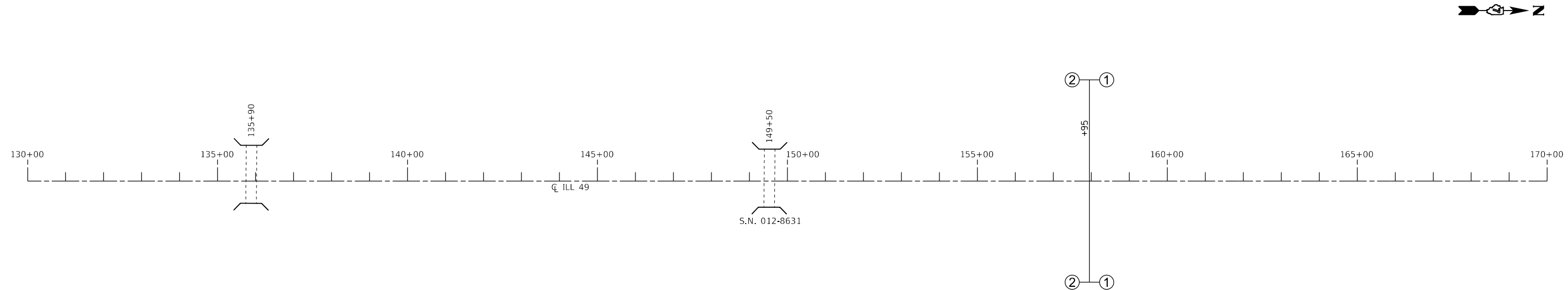
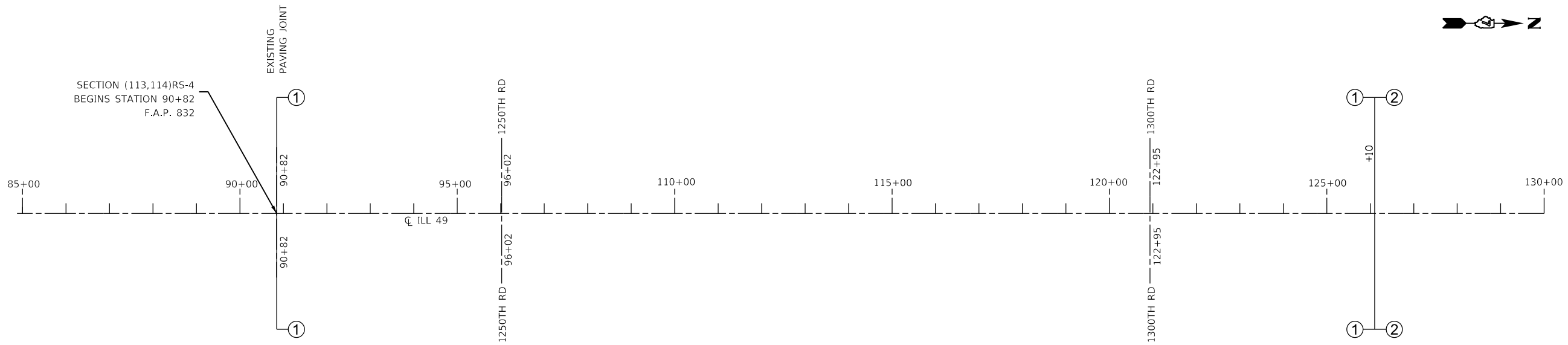

MODEL: Default
 FILE: \\blm1c01.pw.state.il.us\pub\blm1c01\p\blm1c01\Documents\DOT Office\blm1c01\74945\CADD\data\CAD\blm1c01\74945-sheets.dgn

USER NAME = steffemk	DESIGNED -	REVISED -
	DRAWN -	REVISED -
PLOT SCALE = 100.0000' / in.	CHECKED -	REVISED -
PLOT DATE = 12/17/2020	DATE -	REVISED -

STATE OF ILLINOIS
DEPARTMENT OF TRANSPORTATION

PLAN SHEETS - IL 49
 SCALE: SHEET 1 OF 5 SHEETS STA. 85+00 TO STA. 210+00

F.A.P. RTE.	SECTION	COUNTY	TOTAL SHEETS	SHEET NO.
832	(113,114)RS-4	CLARK	46	14
CONTRACT NO. 74945			ILLINOIS FED. AID PROJECT	

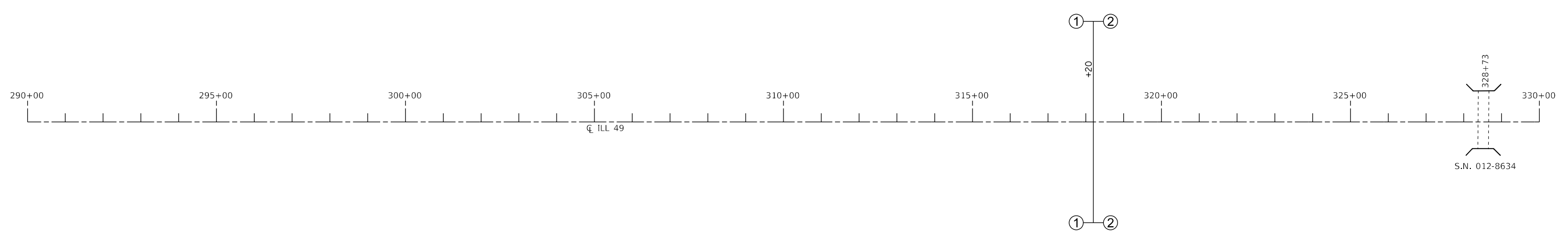
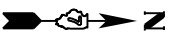
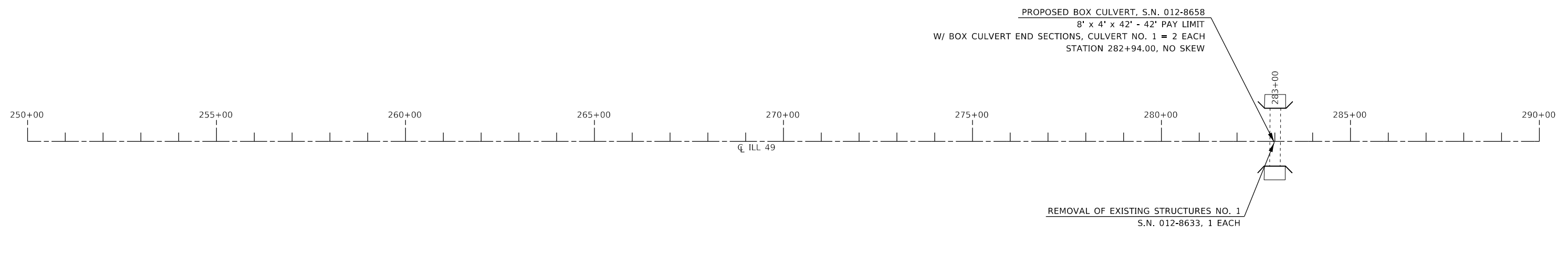
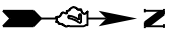
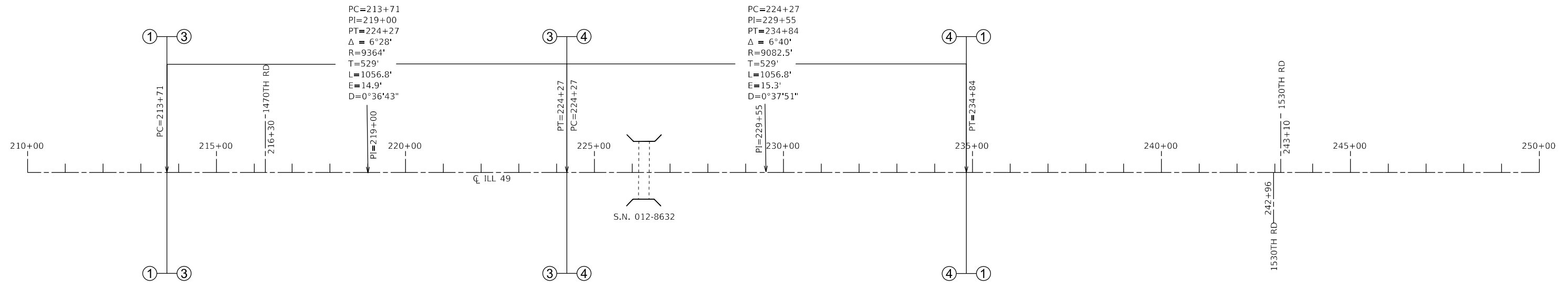
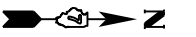

MODEL: Default
 FILE: Model: 2020planroom.dwg
 PROJECT: 74945
 OFFICE: IDOT
 DATE: 12/17/2020

USER NAME = steffemk	DESIGNED -	REVISED -
	DRAWN -	REVISED -
PLOT SCALE = 100.0000' / in.	CHECKED -	REVISED -
PLOT DATE = 12/17/2020	DATE -	REVISED -

STATE OF ILLINOIS
DEPARTMENT OF TRANSPORTATION

PLAN SHEETS - IL 49
 SCALE: SHEET 2 OF 5 SHEETS STA. 210+00 TO STA. 330+00

F.A.P. RTE.	SECTION	COUNTY	TOTAL SHEETS	SHEET NO.
832	(113.114)RS-4	CLARK	46	15
CONTRACT NO. 74945				
ILLINOIS FED. AID PROJECT				

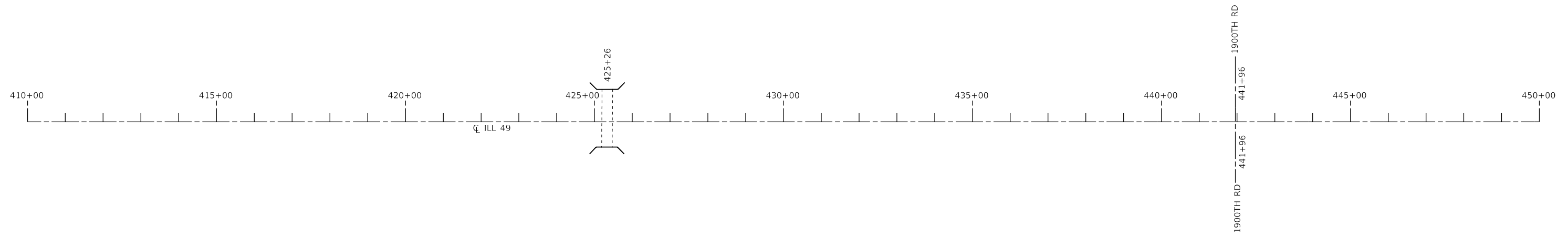
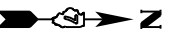
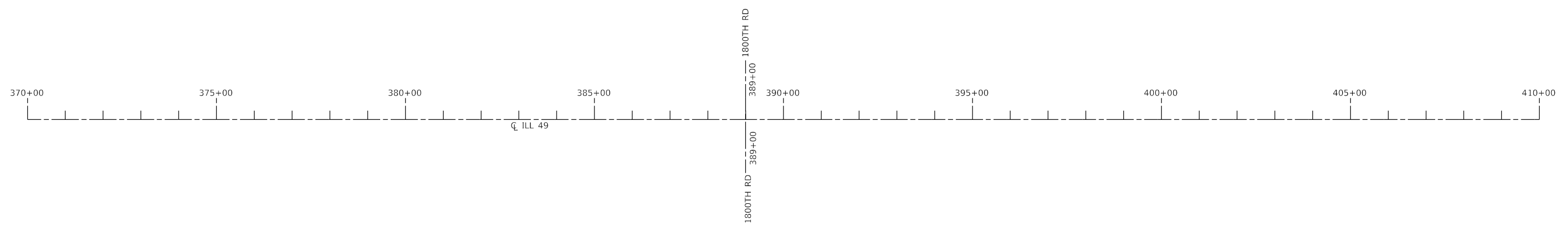
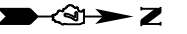
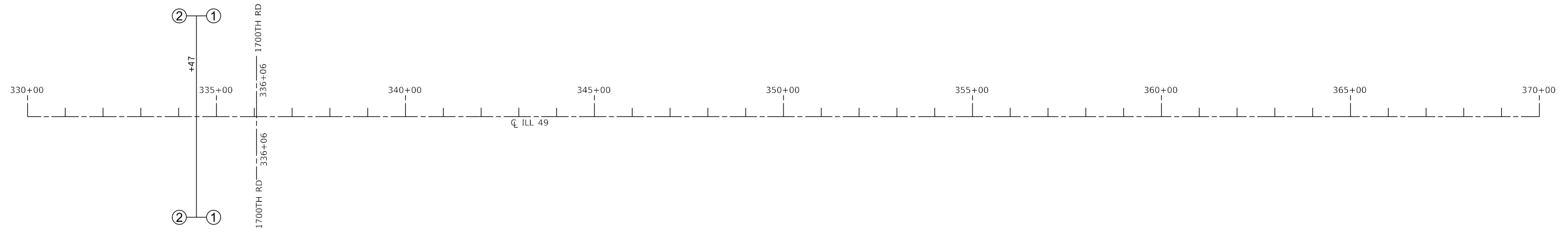

MODEL: Default
 FILE: \\blm1c1-pub\planroom\dat\illinois\pwr\DOT\Documents\DOT_Offices\Illin\7\Projects\74945\CADD\Drawings\74945-114-04.dgn

USER NAME = steffenmk	DESIGNED -	REVISED -
	DRAWN -	REVISED -
PLOT SCALE = 100.0000 ' / in.	CHECKED -	REVISED -
PLOT DATE = 12/17/2020	DATE -	REVISED -

STATE OF ILLINOIS
DEPARTMENT OF TRANSPORTATION

PLAN SHEETS - IL 49
 SCALE: SHEET 3 OF 5 SHEETS STA. 330+00 TO STA. 450+00

F.A.P. RTE.	SECTION	COUNTY	TOTAL SHEETS	SHEET NO.
832	(113,114)RS-4	CLARK	46	16
CONTRACT NO. 74945			ILLINOIS FED. AID PROJECT	

MODEL: Default
 FILE: \\nrcs-pub\pub\baroncom.dwg\illinois\pwr\WIDOT\Documents\DOT_Offices\Illinlet_7\Projects\74945\CADD\data\CAD\sheets\1774945-sheet5a.dgn

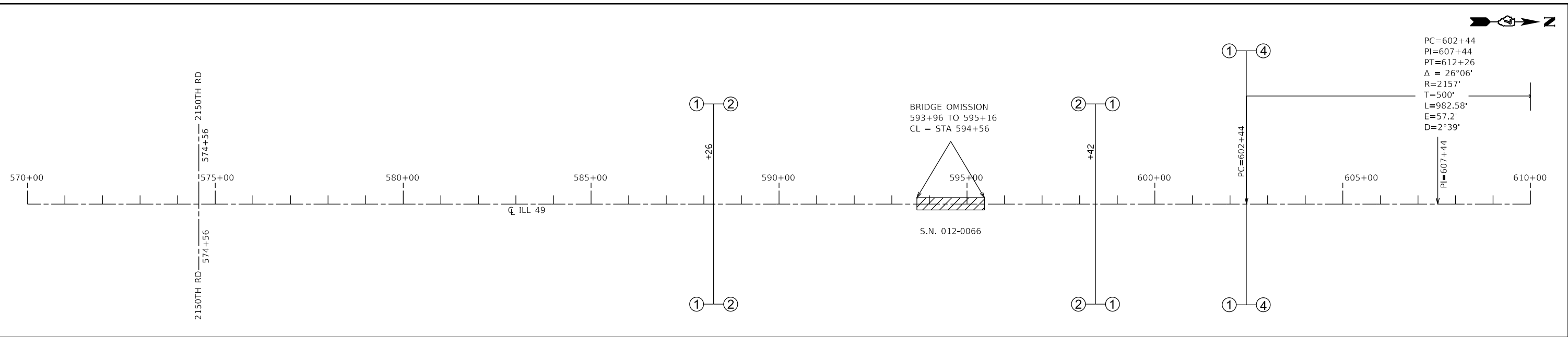

PC=602+44
 PI=607+44
 PT=612+26
 $\Delta = 26^{\circ}06'$
 R=2157'
 T=500'
 L=982.58'
 E=57.2'
 D=2^{\circ}39'

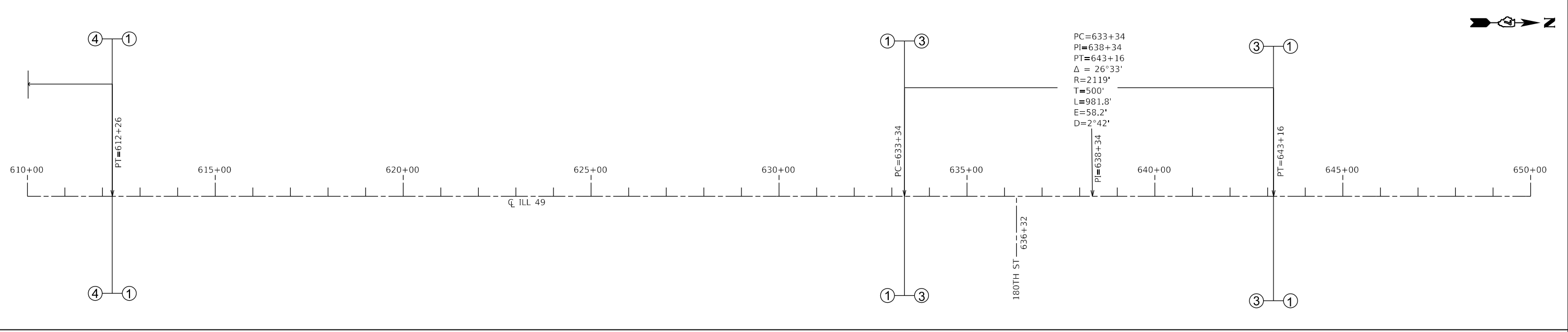

PC=633+34
 PI=638+34
 PT=643+16
 $\Delta = 26^{\circ}33'$
 R=2119'
 T=500'
 L=981.8'
 E=58.2'
 D=2^{\circ}42'

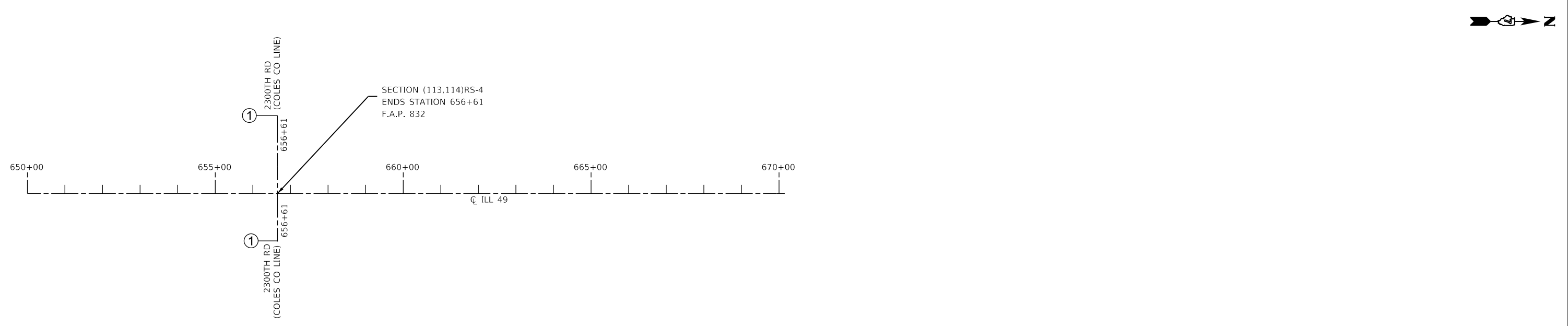

SECTION (113,114)RS-4
 ENDS STATION 656+61
 F.A.P. 832

USER NAME = steffemk	DESIGNED -	REVISED -
	DRAWN -	REVISED -
PLOT SCALE = 100,0000' / in.	CHECKED -	REVISED -
PLOT DATE = 12/17/2020	DATE -	REVISED -





STATE OF ILLINOIS
 DEPARTMENT OF TRANSPORTATION

PLAN SHEETS - IL 49

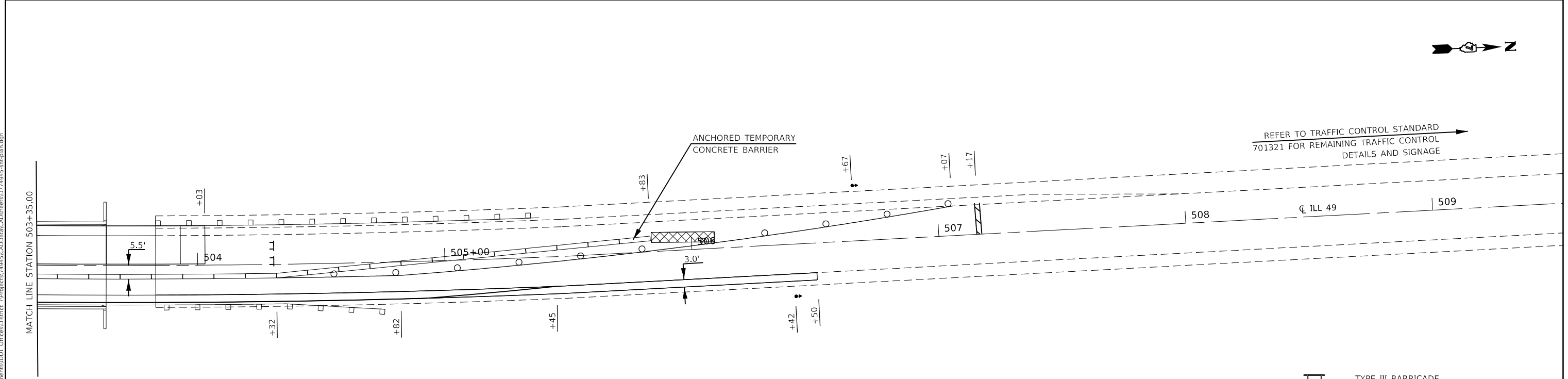
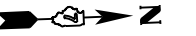
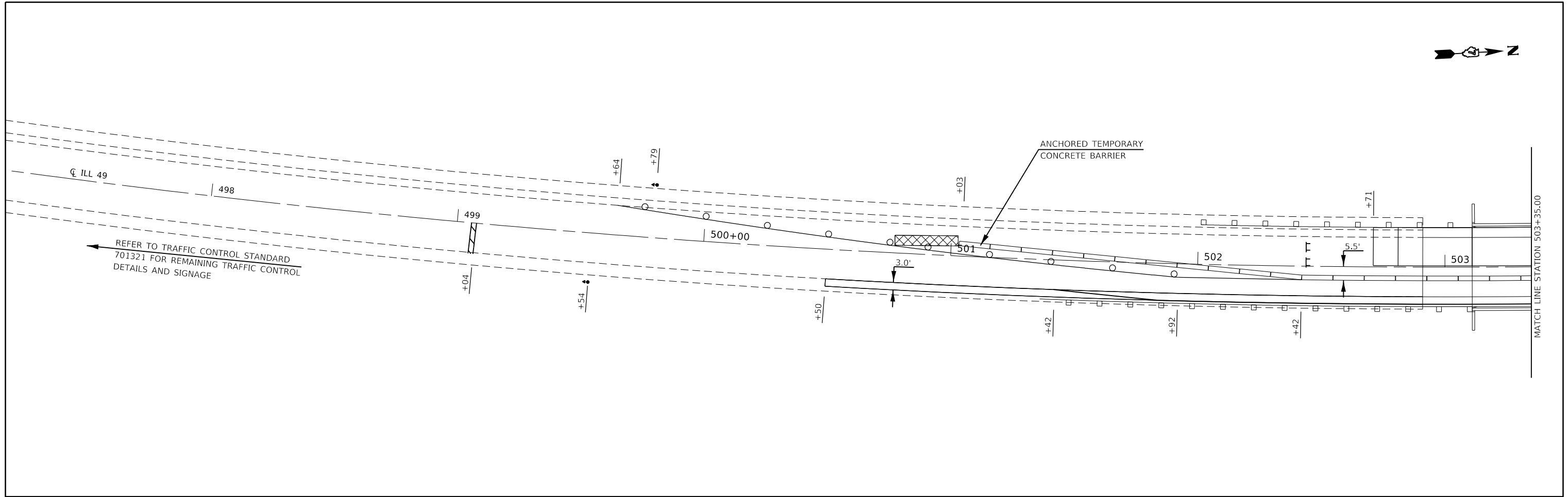
SCALE: SHEET 5 OF 5 SHEETS STA. 570+00 TO STA. 670+00

F.A.P. RTE. 832	SECTION (113,114)RS-4	COUNTY CLARK	TOTAL SHEETS 46	SHEET NO. 18
CONTRACT NO. 74945				
ILLINOIS FED. AID PROJECT				



-  TYPE III BARRICADE
-  STOP BAR
-  TEMPORARY BRIDGE TRAFFIC SIGNALS
-  IMPACT ATTENUATOR
-  TEMPORARY CONCRETE BARRIER

MODEL: Default
 FILE: Model - 20201117.dwg
 PROJECT: 74945-SCAD-Data-CAD-Drawings\74945-SCAD.dwg

USER NAME = steffenmk	DESIGNED -	REVISED -
	DRAWN -	REVISED -
PLOT SCALE = 40.0000' / in.	CHECKED -	REVISED -
PLOT DATE = 12/17/2020	DATE -	REVISED -





**STATE OF ILLINOIS
DEPARTMENT OF TRANSPORTATION**

**STAGING DETAILS
S.N. 012-0061 - STAGE I**

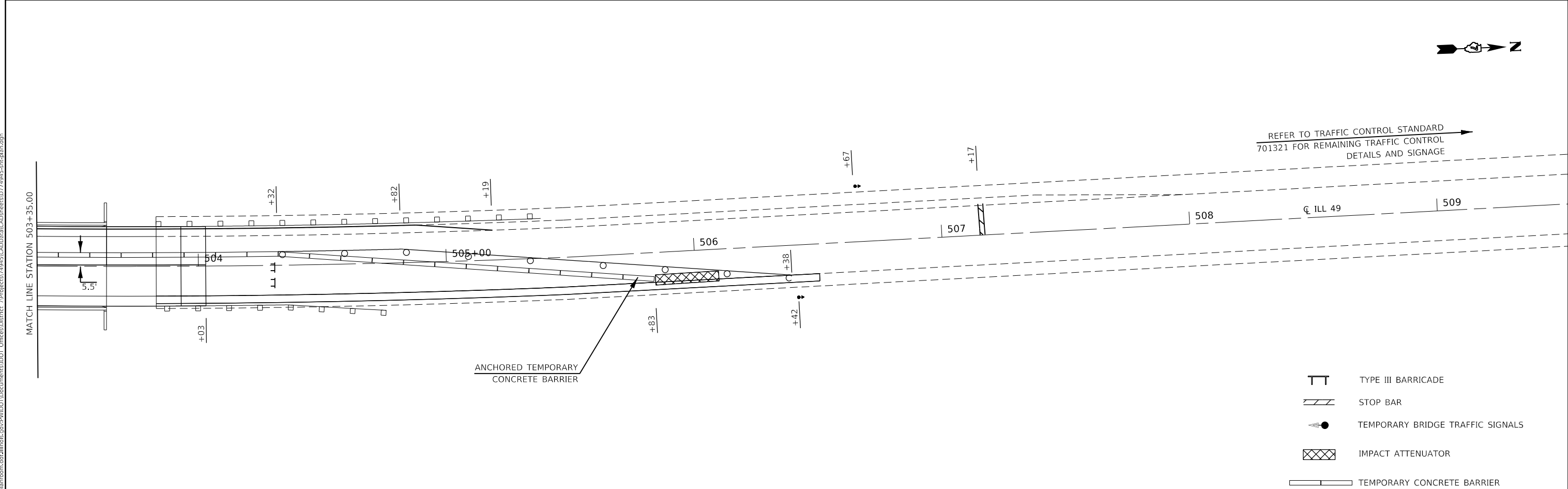
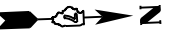
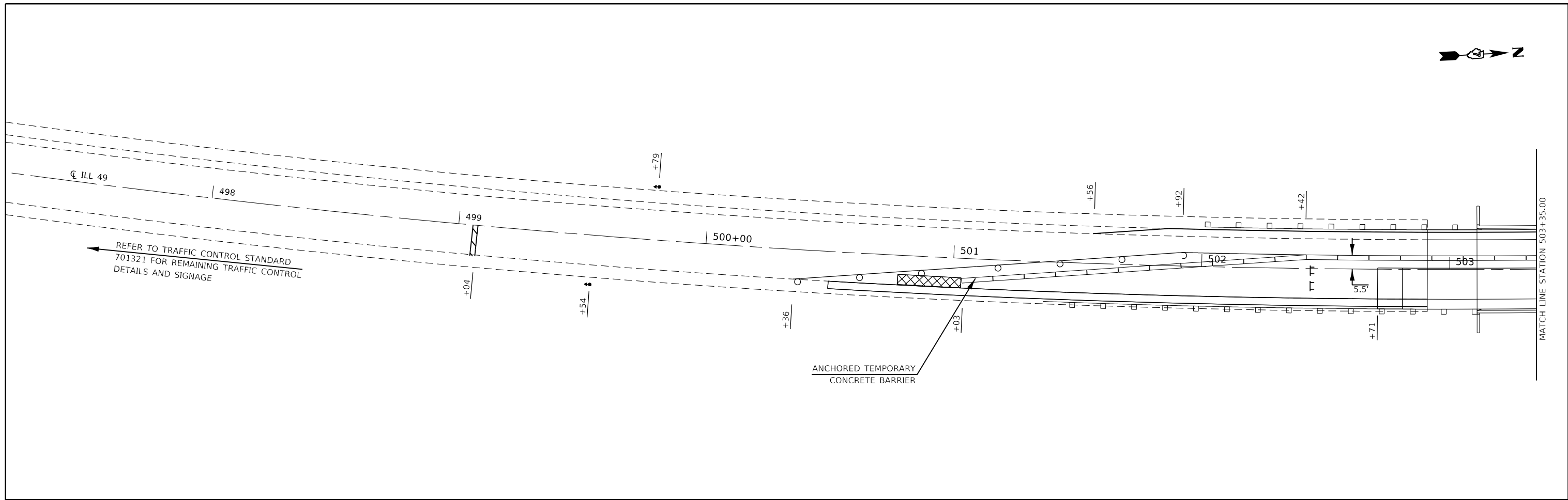
SCALE: SHEET 1 OF 4 SHEETS STA. TO STA.

F.A.P. RTE.	SECTION	COUNTY	TOTAL SHEETS	SHEET NO.
832	(113,114)RS-4	CLARK	46	19
CONTRACT NO. 74945				
ILLINOIS FED. AID PROJECT				



-  TYPE III BARRICADE
-  STOP BAR
-  TEMPORARY BRIDGE TRAFFIC SIGNALS
-  IMPACT ATTENUATOR
-  TEMPORARY CONCRETE BARRIER

MODEL: Default
 FILE: Model_C:\pub\barroom.dwg
 PROJECT: 74945\CAD\DATA\CAD\sheet\74945-sht2.dgn

USER NAME = steffemk	DESIGNED -	REVISED -
	DRAWN -	REVISED -
PLOT SCALE = 40.0000' / in.	CHECKED -	REVISED -
PLOT DATE = 12/17/2020	DATE -	REVISED -

STATE OF ILLINOIS
DEPARTMENT OF TRANSPORTATION

STAGING DETAILS			
S.N. 012-0061 - STAGE II			
SCALE:	SHEET 2	OF 4 SHEETS	STA. TO STA.

F.A.P. RTE.	SECTION	COUNTY	TOTAL SHEETS	SHEET NO.
832	(113,114)RS-4	CLARK	46	20
CONTRACT NO. 74945				
ILLINOIS FED. AID PROJECT				





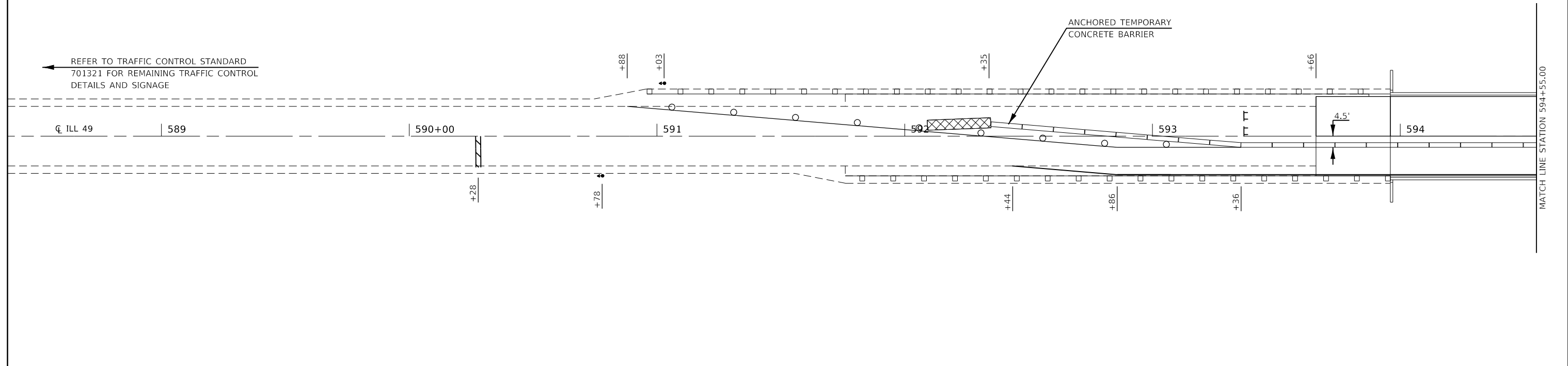

REFER TO TRAFFIC CONTROL STANDARD 701321 FOR REMAINING TRAFFIC CONTROL DETAILS AND SIGNAGE

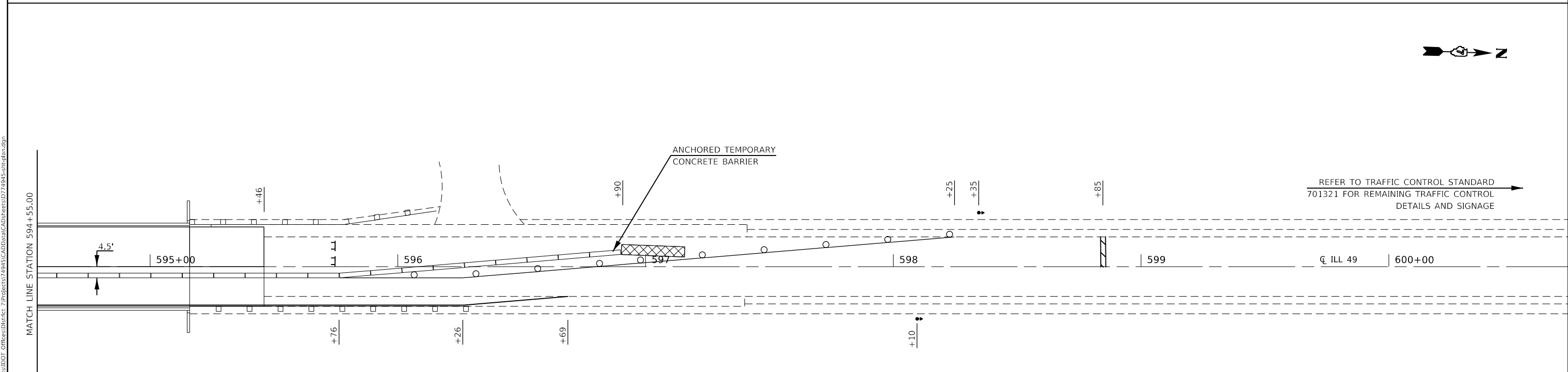

REFER TO TRAFFIC CONTROL STANDARD 701321 FOR REMAINING TRAFFIC CONTROL DETAILS AND SIGNAGE



-  TYPE III BARRICADE
-  STOP BAR
-  TEMPORARY BRIDGE TRAFFIC SIGNALS
-  IMPACT ATTENUATOR
-  TEMPORARY CONCRETE BARRIER

MODEL: Default
FILE: h:\m\c\p\pub\barroom.dwg
PROJECT: 74945\CAD\DATA\CAD\sheet3\DOT_74945-shc3.dgn

USER NAME = steffemk	DESIGNED -	REVISED -
	DRAWN -	REVISED -
PLOT SCALE = 40.0000 ' / in.	CHECKED -	REVISED -
PLOT DATE = 12/17/2020	DATE -	REVISED -

**STATE OF ILLINOIS
DEPARTMENT OF TRANSPORTATION**

**STAGING DETAILS
S.N. 012-0066 - STAGE I**

SCALE: SHEET 3 OF 4 SHEETS STA. TO STA.

F.A.P. RTE.	SECTION	COUNTY	TOTAL SHEETS	SHEET NO.
832	(113,114)RS-4	CLARK	46	21
CONTRACT NO. 74945				
ILLINOIS FED. AID PROJECT				





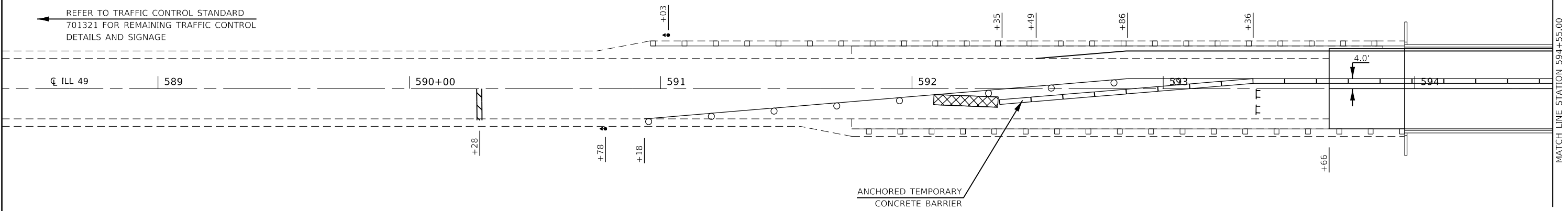

REFER TO TRAFFIC CONTROL STANDARD
701321 FOR REMAINING TRAFFIC CONTROL
DETAILS AND SIGNAGE

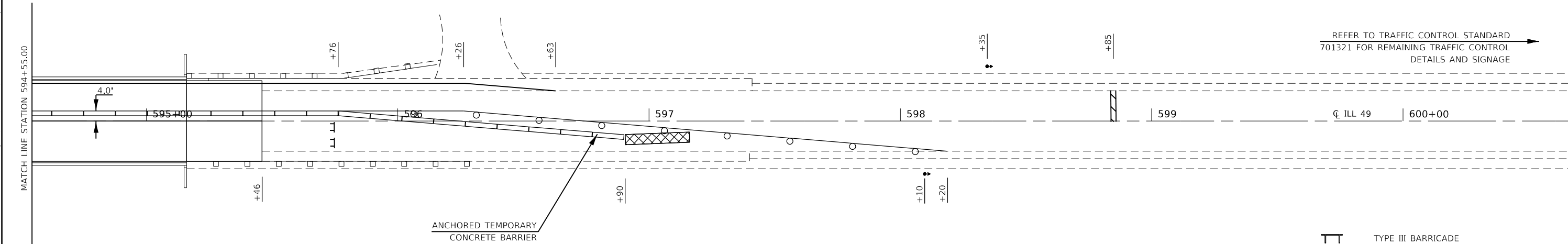

REFER TO TRAFFIC CONTROL STANDARD
701321 FOR REMAINING TRAFFIC CONTROL
DETAILS AND SIGNAGE



-  TYPE III BARRICADE
-  STOP BAR
-  TEMPORARY BRIDGE TRAFFIC SIGNALS
-  IMPACT ATTENUATOR
-  TEMPORARY CONCRETE BARRIER

MODEL: Default
FILE: \\blm1c1-pub\baronm.d\at\illinois.gov\PIWDOT\Documents\DOT_Offices\Director_7\Projects\74945\CADD\Drawings\DOT_74945-Subplan.dgn

USER NAME = steffenmk	DESIGNED -	REVISED -
	DRAWN -	REVISED -
PLOT SCALE = 40.0000' / in.	CHECKED -	REVISED -
PLOT DATE = 12/17/2020	DATE -	REVISED -

**STATE OF ILLINOIS
DEPARTMENT OF TRANSPORTATION**

**STAGING DETAILS
S.N. 012-0066 - STAGE II**

SCALE: SHEET 4 OF 4 SHEETS STA. TO STA.

F.A.P. RTE.	SECTION	COUNTY	TOTAL SHEETS	SHEET NO.
832	(113,114)RS-4	CLARK	46	22
CONTRACT NO. 74945				
ILLINOIS FED. AID PROJECT				

DETOUR PLAN

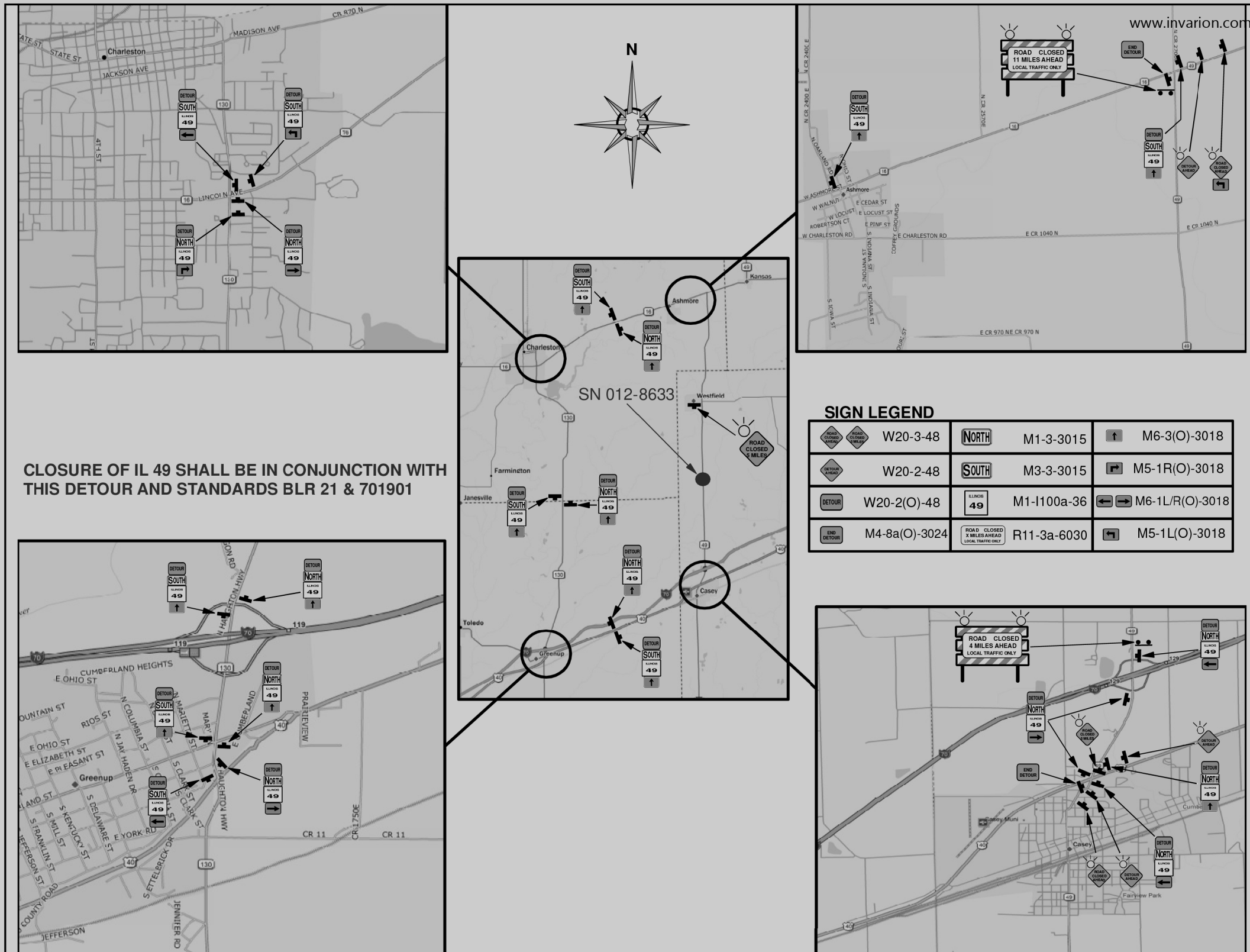

MODEL: Default
 FILE: \\blm\c:\pub\pub\com\dat\illinois\pww\DOT\Documents\DOT - Offices\Dist\ct 7\Projects\74945\CADD\data\AD\sheet\74945-shc-det\illinois.dgn

USER NAME = steffemk	DESIGNED -	REVISED -
	DRAWN -	REVISED -
PLOT SCALE = 100,0000' / in.	CHECKED -	REVISED -
PLOT DATE = 12/17/2020	DATE -	REVISED -

**STATE OF ILLINOIS
DEPARTMENT OF TRANSPORTATION**

DETOUR PLAN SHEET

SCALE: SHEET 1 OF 1 SHEETS STA. TO STA.

F.A.P. RTE.	SECTION	COUNTY	TOTAL SHEETS	SHEET NO.
832	(113,114)RS-4	CLARK	46	23
CONTRACT NO. 74945				
		ILLINOIS	FED. AID PROJECT	

Benchmark: BM 385 - Chisled "X" in Northwest Headwall 012-8633
 Sta. 282+94, 21.3' LT, ELEV. = 659.504
 Existing Structure: Structure 012-8633 is a Cast-in-Place, Reinforced
 Concrete Box Culvert with Span = 6' and Rise = 4'.

INDEX OF SHEETS

1. General Plan and Elevation
- 2.-3. Precast Concrete Box Culvert
Apron End Section Details

GENERAL NOTES

The design fill height for this box is 2 ft. The precast box culvert sections shall conform to the requirements of ASTM C 1577.
 Drain holes shall be provided on exterior culvert walls for each precast box segment with a clear rise greater than 3 ft. The drain hole shall be located within 1/3 of the clear rise of the box culvert, shall not intercept the haunch, and shall conform to the requirements of Article 503.11 of the Standard Specification.
 The 6 in. thick layer of porous granular material required for the precast concrete box culvert per Art. 540.06 of the Standard Specifications shall also apply to the end sections. Cost of the porous granular material will not be paid for separately but shall be included in the unit price of the work for which it is required.
 Nonwoven geotextile fabric shall conform to the requirements of Art. 1080.01 of the Standard Specifications. The minimum weight of the fabric shall be 6 ounces per square yard.
 Precast concrete box culverts and box culvert end sections shall be backfilled with Porous Granular Embankment below the top of the box culvert extending to a vertical plane 2 ft from the exterior sides of the culvert, 2 ft from the back face of the end sections, and not closer than 2 ft from the face of embankment.

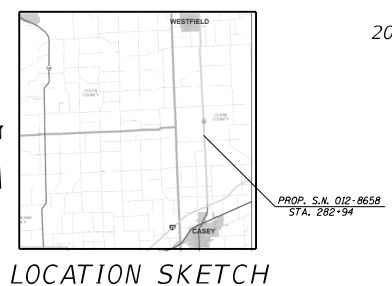
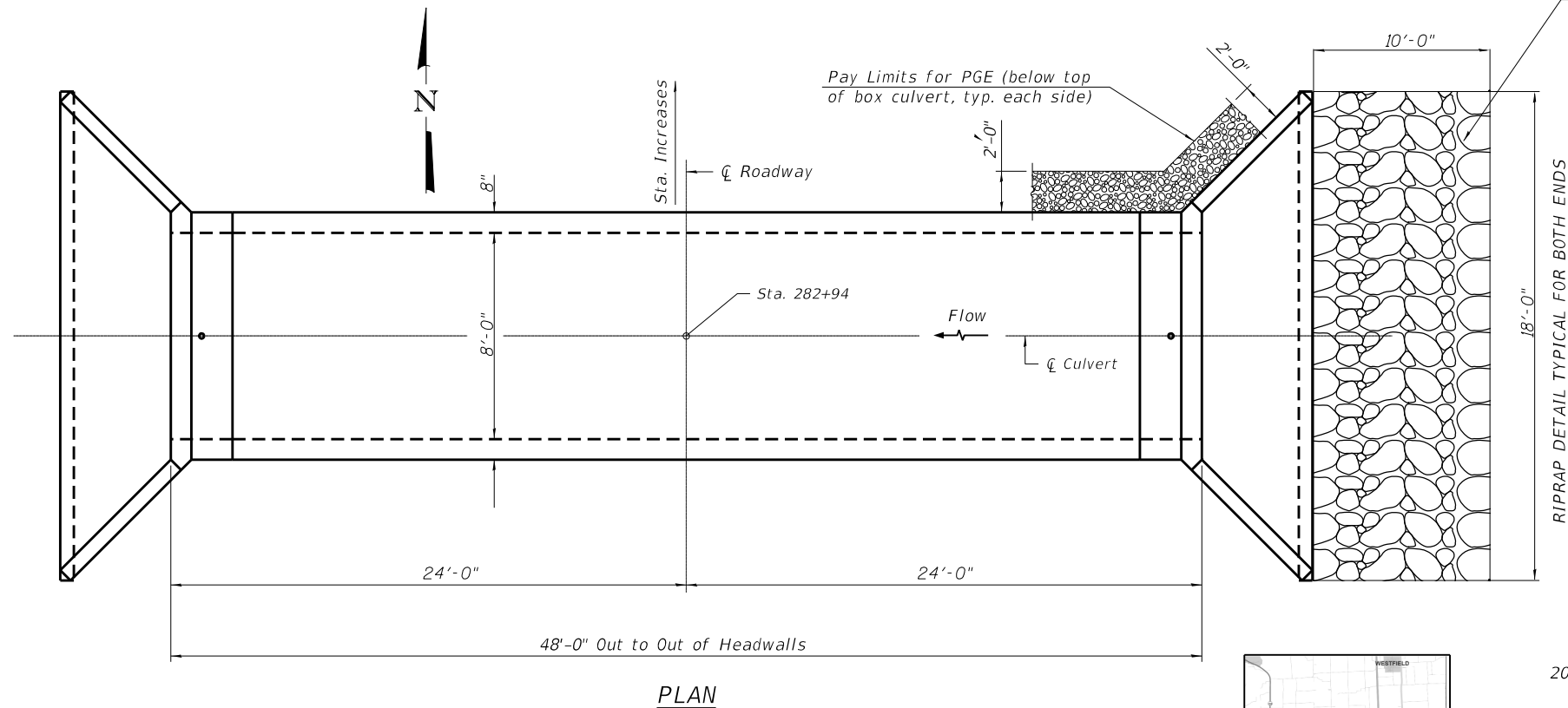
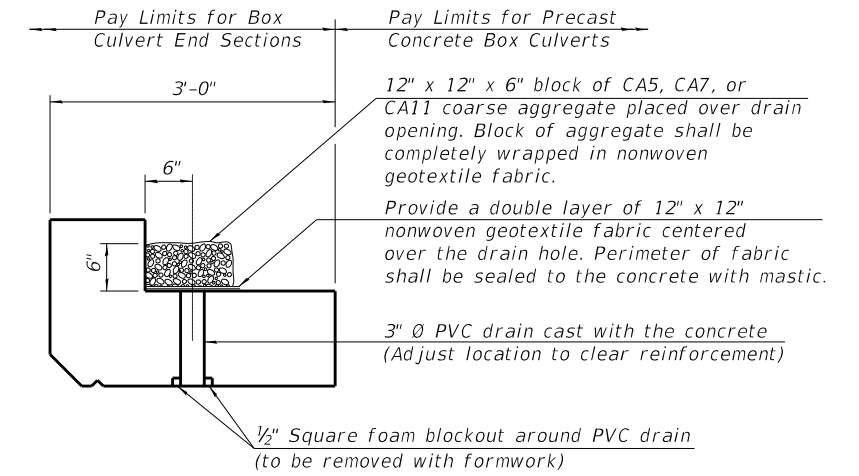
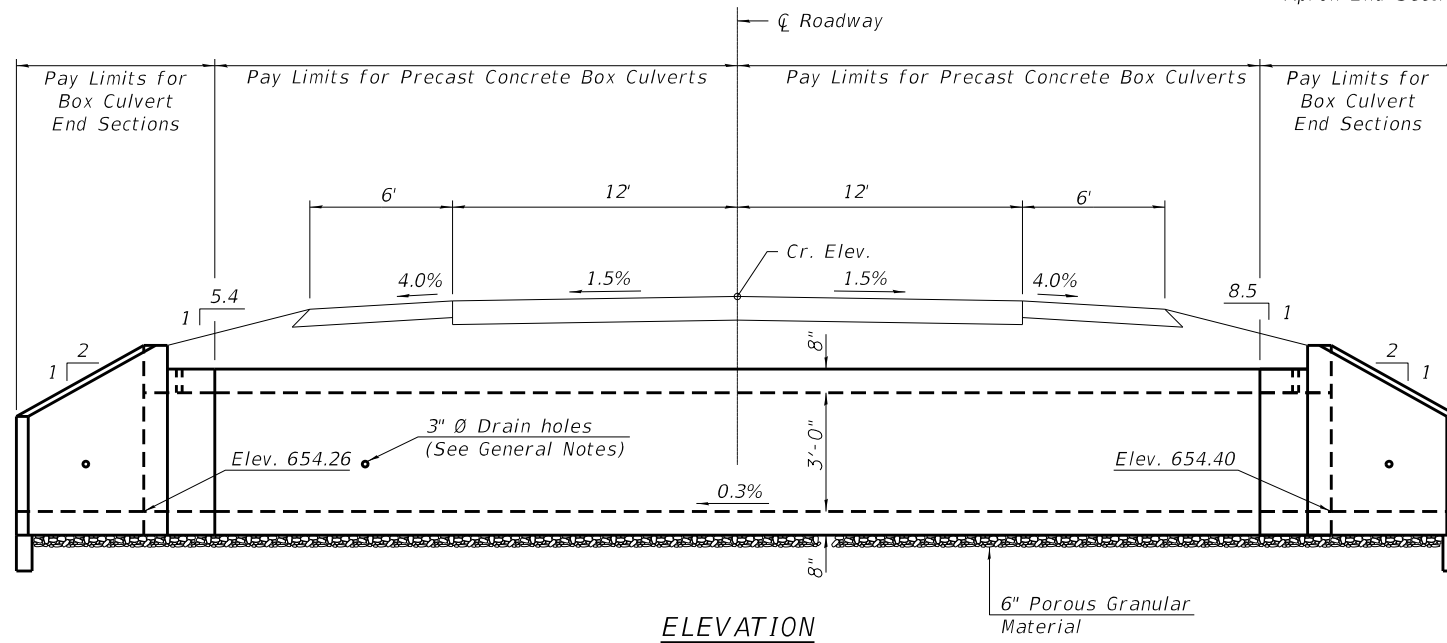

(All costs associated with furnishing and constructing the above drain detail will not be measured for payment but shall be included in the contract unit price for the associated work.)

TOTAL BILL OF MATERIAL

ITEM	UNIT	TOTAL
Removal of Existing Structures	Each	1
Box Culvert End Sections, Culvert No. 1	Each	2
Precast Concrete Box Culverts, 8' x 3'	Foot	42
Porous Granular Embankment	Cu. Yd.	37
Stone RipRap, Class A3	Sq. Yd.	40
Filter Fabric	Sq. Yd.	40
Geocomposite Wall Drain	Sq. Yd.	53.0
Membrane Waterproofing System for Buried Structures	Sq. Yd.	53.0

DESIGN SPECIFICATIONS

2012 AASHTO LRFD Bridge Design Specifications
 6th Edition with 2013 Interims

LOADING HL-93

DESIGN STRESSES

PRECAST UNITS

f'c = 5,000 psi
 fy = 65,000 psi (Welded Wire Reinforcement)

GENERAL PLAN AND ELEVATION
SINGLE 8' X 3' PRECAST BOX CULVERT
F.A.P. RTE. 832 SEC. (113,114)RS-4
CLARK COUNTY
STATION 282+94
S.N. 012-8658

SCB-GPE

USER NAME = SUSERS DESIGNED - DRAWN - PLOT SCALE = SCALES PLOT DATE = SDATES	DESIGNED - DRAWN - CHECKED - DATE -	REVISED - REVISED - REVISED - REVISED -	STATE OF ILLINOIS DEPARTMENT OF TRANSPORTATION	PRECAST CONCRETE BOX CULVERT STRUCTURE NO. 012-8658		F.A.P. RTE. 832	SECTION (113,114)RS-4	COUNTY CLARK	TOTAL SHEETS 46	SHEET NO. 24
				SCALE:	SHEET 1 OF 4 SHEETS	STA. TO STA.	ILLINOIS FED. AID PROJECT		CONTRACT NO. 74945	

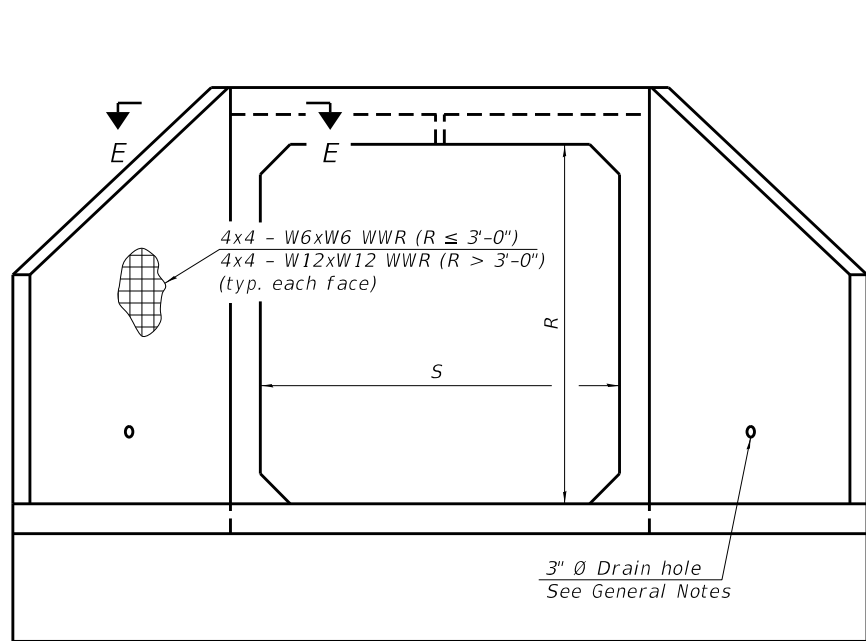

END VIEW

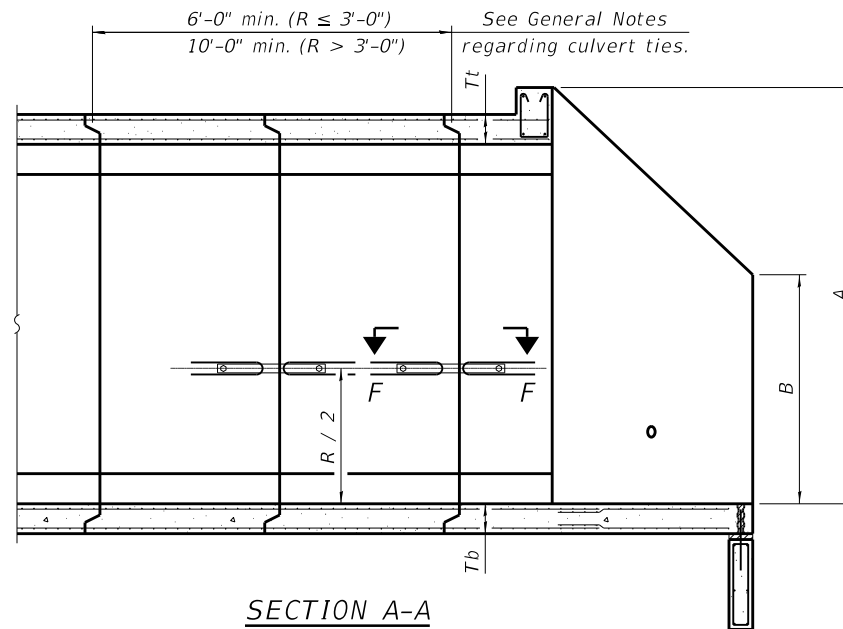

SECTION A-A

GENERAL NOTES

Box Culvert End Sections shall be constructed according to the requirements of Section 540 of the Standard Specifications except as modified herein. End sections will be paid for at the contract unit price per each for Box Culvert End Sections.

The Contractor may furnish the end section as a single precast concrete piece or construct the end section in the field using cast-in-place (CIP) construction. For CIP construction, the bottom slab thickness shall be increased by 2" and the clear cover to the bottom mat of reinforcement shall be increased to 3".

Box section dimensions, materials, and reinforcement details for Box Culvert End Sections shall be according to the requirements for ASTM C 1577 as required for the design of the portion of the culvert within the limits of Precast Concrete Box Culverts except as modified herein.

The number of culvert ties shall be sufficient to engage the minimum length of culvert barrel shown within the pay limits for Precast Concrete Box Culverts and will be dependent upon the length of box culvert segments furnished by the Contractor. Culvert ties are not required for box culverts having a rise (R) less than or equal to 3 ft and a span (S) greater than or equal to 10 ft.

All costs associated with furnishing and installing or constructing the toewall and culvert ties will not be measured for payment but shall be included in the unit price for Box Culvert End Sections of the culvert number specified.

Shop drawings that detail slab thickness and reinforcement layout for the Box Culvert End Sections shall be provided to the Engineer for review and approval. Reinforcement bars not detailed herein shall be detailed with a clear distance at the end of the reinforcement not less than 1/2" nor more than 2". For the precast option, it shall be the Contractor's responsibility for determining a method of handling and a construction procedure shall be included on the shop drawings. The Contractor shall determine and detail in the shop drawings any necessary strengthening or stiffening provisions necessary to handle the precast segment. Any required modifications shall be at no extra charge.

The Contractor may use reinforcement bars in lieu of welded wire reinforcement (WWR). Reinforcement bars shall be limited to the sizes of #3 through #5 bars, a maximum spacing of the lesser of 8" or the member thickness, and shall result in an area of reinforcement equal to or greater than that provided by the WWR. Minimum lap lengths detailed herein are applicable to WWR and reinforcement bars.

Reinforcement (circumferential and longitudinal) in the culvert barrel portion of the end section being lapped with reinforcement from the wingwalls or bottom slab of the end section shall not be less than that required by ASTM C 1577 for the design fill height or the reinforcement detailed for the end section, whichever is greater.

One drain hole shall be provided in each wingwall for end sections of box culverts having an opening with a clear rise greater than 3 ft. The drain hole shall be located within the lower 1/3 of the clear rise of the box culvert and shall conform to the requirements of Article 503.11 of the Standard Specifications.

APRON END SECTION DIMENSIONS

Span (S)	Rise (R)	Tt	Tb	Ts	A	B	C	D	E	Concrete Cu. Yd.	Culvert Ties Required
3'-0"	2'-0"	7"	6"	4"	3'-4"	2'-2"	2'-10 3/8"	4'-1"	10'-4 5/8"	2.8	Yes
3'-0"	2'-0"	4"	4"	4"	3'-1"	2'-1"	2'-7 7/8"	3'-9"	9'-11"	2.3	Yes
3'-0"	3'-0"	7"	6"	4"	4'-4"	2'-8"	3'-10 3/8"	5'-6"	12'-4 3/8"	3.7	Yes
3'-0"	3'-0"	4"	4"	4"	4'-1"	2'-7"	3'-7 7/8"	5'-2"	11'-11"	3.1	Yes
4'-0"	2'-0"	7.5"	6"	5"	3'-4 1/2"	2'-2 1/2"	2'-11 3/8"	4'-2"	11'-8"	3.3	Yes
4'-0"	2'-0"	5"	5"	5"	3'-2"	2'-1"	2'-8 1/2"	3'-10"	11'-2 3/8"	2.8	Yes
4'-0"	3'-0"	7.5"	6"	5"	4'-4 1/2"	2'-8 1/2"	3'-11 3/8"	5'-7"	13'-8 1/8"	4.2	Yes
4'-0"	3'-0"	5"	5"	5"	4'-2"	2'-7"	3'-8 1/2"	5'-3"	13'-2 3/8"	3.7	Yes
4'-0"	4'-0"	7.5"	6"	5"	5'-4 1/2"	3'-2 1/2"	4'-11 3/8"	7'-0"	15'-8 1/8"	5.3	Yes
4'-0"	4'-0"	5"	5"	5"	5'-2"	3'-1"	4'-8 3/8"	6'-8"	15'-2 1/2"	4.7	Yes
5'-0"	2'-0"	8"	7"	6"	3'-5"	2'-3"	2'-11 3/8"	4'-2"	12'-10"	3.9	Yes
5'-0"	2'-0"	6"	6"	6"	3'-3"	2'-2"	2'-10"	4'-0"	12'-7 1/4"	3.5	Yes
5'-0"	3'-0"	8"	7"	6"	4'-5"	2'-9"	3'-11 3/8"	5'-7"	14'-10 1/8"	4.9	Yes
5'-0"	3'-0"	6"	6"	6"	4'-3"	2'-8"	3'-10"	5'-5"	14'-7 1/4"	4.5	Yes
5'-0"	4'-0"	8"	7"	6"	5'-5"	3'-3"	4'-11 3/8"	7'-0"	16'-10 1/8"	6.1	Yes
5'-0"	4'-0"	6"	6"	6"	5'-3"	3'-2"	4'-9 1/4"	6'-9"	16'-5 1/8"	5.5	Yes
5'-0"	5'-0"	8"	7"	6"	6'-5"	3'-9"	5'-11 3/8"	8'-5"	18'-10 1/8"	7.4	Yes
5'-0"	5'-0"	6"	6"	6"	6'-3"	3'-8"	5'-9 1/4"	8'-2"	18'-5 1/8"	6.8	Yes
6'-0"	2'-0"	8"	7"	7"	3'-5"	2'-3"	2'-11 3/8"	4'-2"	14'-0"	4.3	Yes
6'-0"	2'-0"	7"	7"	7"	3'-4"	2'-2"	2'-10 3/8"	4'-1"	13'-10 3/8"	4.2	Yes
6'-0"	3'-0"	8"	7"	7"	4'-5"	2'-9"	3'-11 3/8"	5'-7"	16'-0 1/8"	5.4	Yes
6'-0"	3'-0"	7"	7"	7"	4'-4"	2'-8"	3'-10 3/8"	5'-6"	15'-10 3/8"	5.2	Yes
6'-0"	4'-0"	8"	7"	7"	5'-5"	3'-3"	4'-11 3/8"	7'-0"	18'-0 1/8"	6.5	Yes
6'-0"	4'-0"	7"	7"	7"	5'-4"	3'-2"	4'-10 3/4"	6'-11"	17'-10 3/4"	6.5	Yes
6'-0"	5'-0"	8"	7"	7"	6'-5"	3'-9"	5'-11 3/8"	8'-5"	20'-0 1/8"	8.0	Yes
6'-0"	5'-0"	7"	7"	7"	6'-4"	3'-8"	5'-10 3/4"	8'-4"	19'-10 3/4"	7.8	Yes
6'-0"	6'-0"	8"	7"	7"	7'-5"	4'-3"	6'-11 1/2"	9'-10"	22'-0 1/4"	9.5	Yes
6'-0"	6'-0"	7"	7"	7"	7'-4"	4'-2"	6'-10 3/4"	9'-9"	21'-10 3/4"	9.3	Yes
7'-0"	2'-0"	8"	8"	8"	3'-5"	2'-3"	2'-11 3/8"	4'-2"	15'-2"	4.9	Yes
7'-0"	3'-0"	8"	8"	8"	4'-5"	2'-9"	3'-11 3/8"	5'-7"	17'-2 1/8"	6.1	Yes
7'-0"	4'-0"	8"	8"	8"	5'-5"	3'-3"	4'-11 3/8"	7'-0"	19'-2 1/8"	7.4	Yes
7'-0"	4'-0"	8"	8"	8"	5'-4"	3'-2"	4'-10 3/4"	6'-11"	17'-10 3/4"	6.5	Yes
7'-0"	5'-0"	8"	8"	8"	6'-5"	3'-9"	5'-11 3/8"	8'-5"	21'-2 1/8"	8.9	Yes
7'-0"	6'-0"	8"	8"	8"	7'-5"	4'-3"	6'-11 1/2"	9'-10"	23'-2 1/4"	10.6	Yes
8'-0"	2'-0"	8"	8"	8"	3'-5"	2'-3"	2'-11 3/8"	4'-2"	16'-2"	5.3	Yes
8'-0"	3'-0"	8"	8"	8"	4'-5"	2'-9"	3'-11 3/8"	5'-7"	18'-2 1/8"	6.5	Yes
8'-0"	4'-0"	8"	8"	8"	5'-5"	3'-3"	4'-11 3/8"	7'-0"	20'-2 1/8"	7.8	Yes
8'-0"	5'-0"	8"	8"	8"	6'-5"	3'-9"	5'-11 3/8"	8'-5"	22'-2 1/8"	9.3	Yes
8'-0"	6'-0"	8"	8"	8"	7'-5"	4'-3"	6'-11 1/2"	9'-10"	24'-2 1/4"	11.0	Yes
9'-0"	2'-0"	9"	9"	9"	3'-6"	2'-3"	3'-0 3/4"	4'-4"	17'-6 1/8"	6.2	Yes
9'-0"	3'-0"	9"	9"	9"	4'-6"	2'-9"	4'-0 3/4"	5'-9"	19'-6 1/8"	7.5	Yes
9'-0"	4'-0"	9"	9"	9"	5'-6"	3'-3"	5'-0 3/4"	7'-2"	21'-6 1/8"	9.0	Yes
9'-0"	5'-0"	9"	9"	9"	6'-6"	3'-9"	6'-0 3/8"	8'-7"	23'-7"	10.6	Yes
9'-0"	6'-0"	9"	9"	9"	7'-6"	4'-3"	7'-0 1/8"	9'-11"	25'-5 5/8"	12.4	Yes
10'-0"	2'-0"	10"	10"	10"	3'-7"	2'-4"	3'-1 1/2"	4'-5"	18'-10 1/4"	7.1	No
10'-0"	3'-0"	10"	10"	10"	4'-7"	2'-10"	4'-1 1/2"	5'-10"	20'-10 1/4"	8.6	No
10'-0"	4'-0"	10"	10"	10"	5'-7"	3'-4"	5'-1 1/2"	7'-3"	22'-10 3/8"	10.2	Yes
10'-0"	5'-0"	10"	10"	10"	6'-7"	3'-10"	6'-1 1/2"	8'-8"	24'-10 3/8"	12.0	Yes
10'-0"	6'-0"	10"	10"	10"	7'-7"	4'-4"	7'-1 1/2"	10'-1"	26'-10 3/8"	13.9	Yes
11'-0"	2'-0"	11"	11"	11"	3'-8"	2'-4"	3'-2 1/8"	4'-7"	20'-3 1/8"	8.2	No
11'-0"	3'-0"	11"	11"	11"	4'-8"	2'-10"	4'-2 1/8"	6'-0"	22'-3 1/8"	9.8	No
11'-0"	4'-0"	11"	11"	11"	5'-8"	3'-4"	5'-2 1/4"	7'-4"	24'-1 3/4"	11.5	Yes
11'-0"	5'-0"	11"	11"	11"	6'-8"	3'-10"	6'-2 1/4"	8'-9"	26'-1 3/4"	13.3	Yes
11'-0"	6'-0"	11"	11"	11"	7'-8"	4'-4"	7'-2 1/4"	10'-2"	28'-1 1/8"	15.5	Yes
12'-0"	2'-0"	12"	12"	12"	3'-9"	2'-5"	3'-3 5/8"	4'-8"	21'-6 1/2"	9.3	No
12'-0"	3'-0"	12"	12"	12"	4'-9"	2'-11"	4'-3 5/8"	6'-1"	23'-6 1/2"	11.1	No
12'-0"	4'-0"	12"	12"	12"	5'-9"	3'-5"	5'-3 5/8"	7'-6"	25'-6 3/8"	13.0	Yes
12'-0"	5'-0"	12"	12"	12"	6'-9"	3'-11"	6'-3 5/8"	8'-11"	27'-6 3/8"	14.1	Yes
12'-0"	6'-0"	12"	12"	12"	7'-9"	4'-5"	7'-3 5/8"	10'-4"	29'-6 3/8"	17.4	Yes

Note:

Two sets of apron end section dimensions are shown above for some box culvert sizes due to the top and bottom slabs having different thicknesses per ASTM C 1577 for design fill heights less than 2 ft.

(Sheet 1 of 2)

MODEL: Default FILE: Model: PrecastConcreteBoxCulvertApronEnd.dwg PROJECT: 74945 CAD: DataCAD: 74945-PC: det: dlk.dwg

SCB-AES

2-17-2017

USER NAME = stefenmk	DESIGNED -	REVISED -
	DRAWN -	REVISED -
PLOT SCALE = 100.0000' / in.	CHECKED -	REVISED -
PLOT DATE = 12/17/2020	DATE -	REVISED -

STATE OF ILLINOIS
DEPARTMENT OF TRANSPORTATION

PRECAST CONCRETE BOX CULVERT APRON END
SECTION DETAILS - STRUCTURE NO. 012-8658

SCALE: SHEET 2 OF 4 SHEETS STA. TO STA.

F.A.P. RTE. 832	SECTION (113,114)RS-4	COUNTY CLARK	TOTAL SHEETS 46	SHEET NO. 25
CONTRACT NO. 74945				
ILLINOIS FED. AID PROJECT				

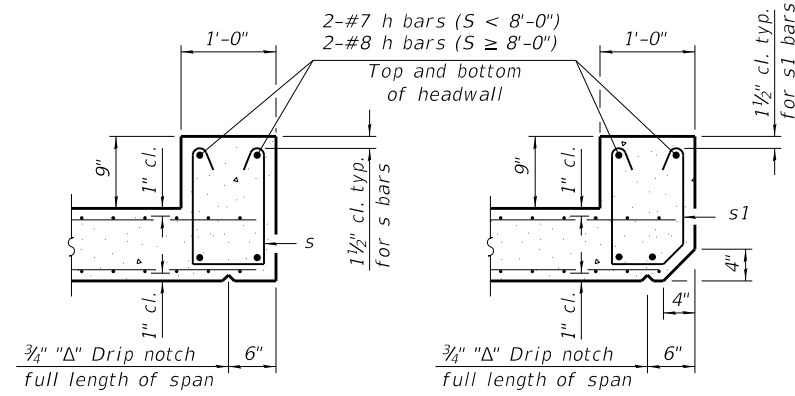

SECTION B-B
(Top slab at downstream end)

SECTION B-B
(Top slab at upstream end)

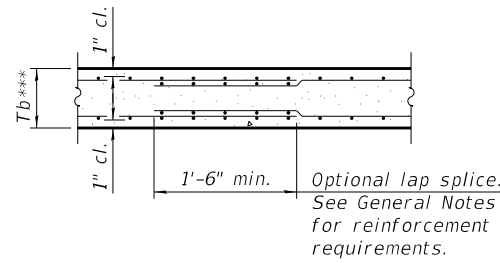

SECTION B-B
(Bottom Slab)

*** This dimension shall be increased by 2" for CIP construction.

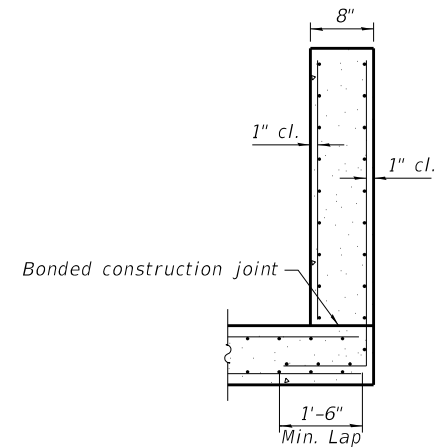

SECTION C-C

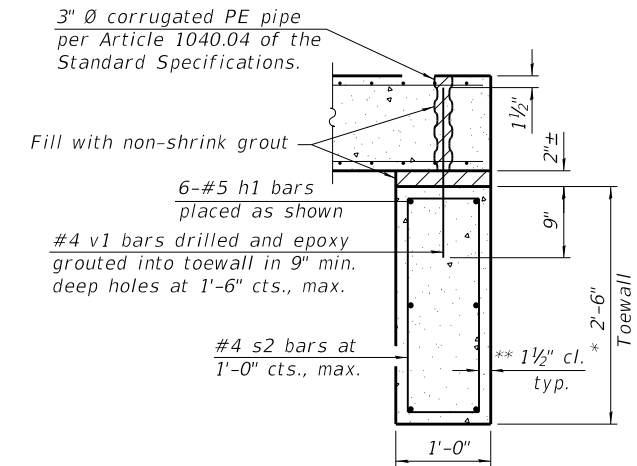

SECTION D-D

TOEWALL CONSTRUCTION SEQUENCE

1. Perform excavation and construct toewall.
2. Backfill accordingly and place bedding for precast box culvert end sections.
3. Set precast box culvert end section.
4. Drill and epoxy grout reinforcement in toewall in accordance with Section 584 of the Standard Specifications.
5. Pressure grout voids using non-shrink grout conforming to Section 1024 of the Standard Specifications.

* The Contractor may furnish a precast or cast-in-place toewall. The Contractor shall be responsible for the strength and stability of the precast toewall during handling. Additional lifting points may be required depending upon the length of the toewall or the Contractor may need to modify the design of the toewall for the proposed handling method.

** If soil conditions permit, the sides of the toewall may be poured directly against the soil. The clear cover on the sides of the toewall shall be increased to 3" by increasing the thickness of the toewall.

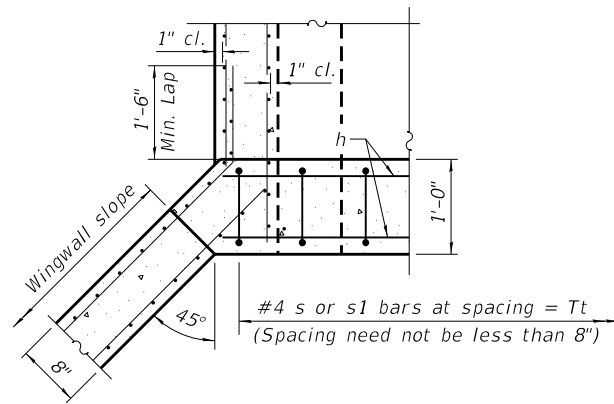

SECTION E-E

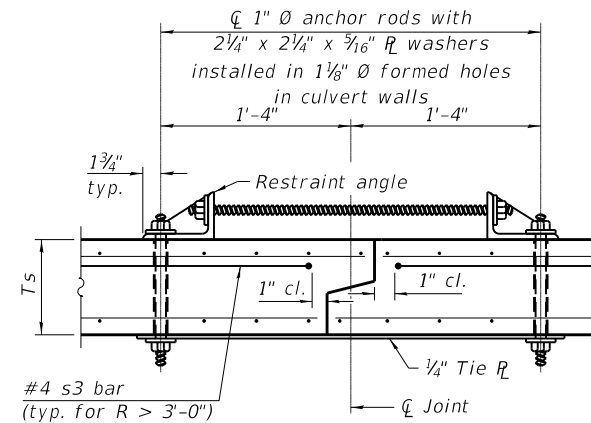

SECTION F-F
(Showing culvert tie details)

Notes:

1" Ø anchor rods for the culvert ties shall conform to the requirements of ASTM F1554, Grade 105. Structural steel for the tie plate and restraint angle shall conform to the requirements of Article 1006.04 of the Standard Specifications. All components of the culvert tie detail shall be galvanized according to the requirements of AASHTO M 111 or M 232 as applicable. 2 1/4" x 2 1/4" x 3/16" plate washers shall be provided under each nut required for the anchor rods. Anchor rods connecting precast sections shall be brought to a snug tight condition followed by an additional 1/2 turn on one of the nuts for anchor rods installed in the walls. Match marks shall be provided on the bolt and nut to verify relative rotation between the bolt and the nut. Holes in the walls for the culvert tie assembly may be drilled using core bits in lieu of using formed holes.

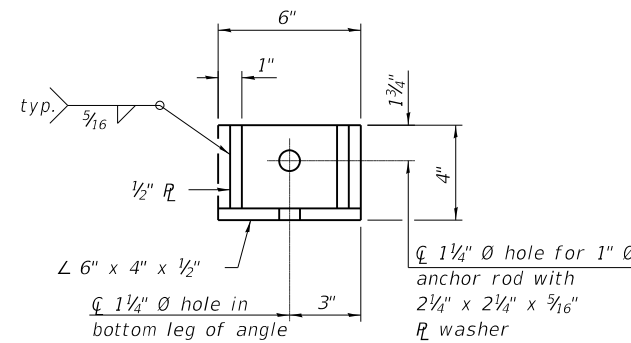

RESTRAINT ANGLE DETAIL

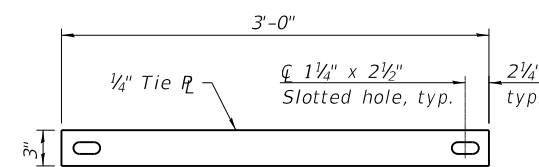

TIE PLATE DETAIL

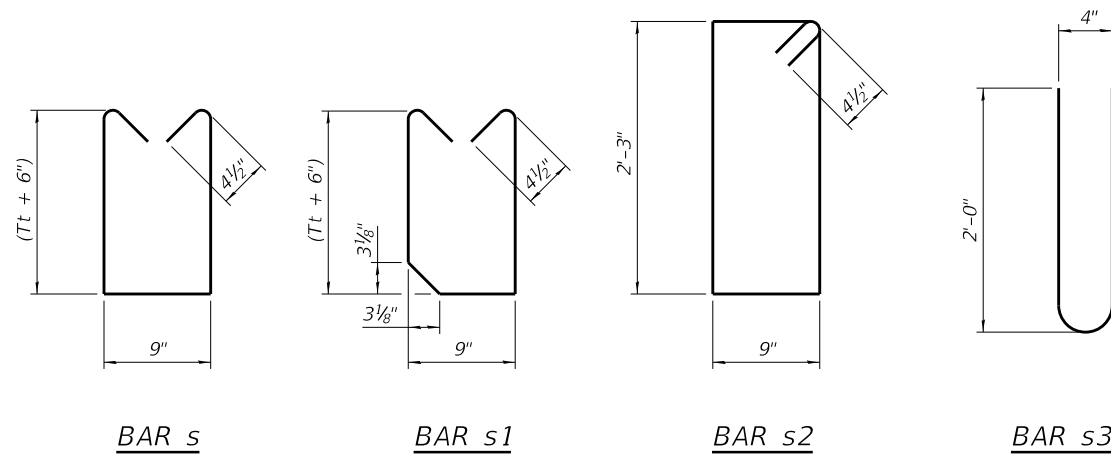

BAR s

BAR s1

BAR s2

BAR s3

SCB-AES

2-17-2017



(Sheet 2 of 2)

**STATE OF ILLINOIS
DEPARTMENT OF TRANSPORTATION**

**PRECAST CONCRETE BOX CULVERT APRON END
SECTION DETAILS - STRUCTURE NO. 012-8658**

SCALE: SHEET 3 OF 4 SHEETS STA. TO STA.

F.A.P. RTE.	SECTION	COUNTY	TOTAL SHEETS	SHEET NO.
832	(113,114)RS-4	CLARK	46	26
CONTRACT NO. 74945				
ILLINOIS FED. AID PROJECT				

LEGEND	
	POROUS GRANULAR EMBANKMENT
	BOX CULVERT BEDDING (CA-7 OR CA-11)

CL
BOX CULVERT
STA. 282+94

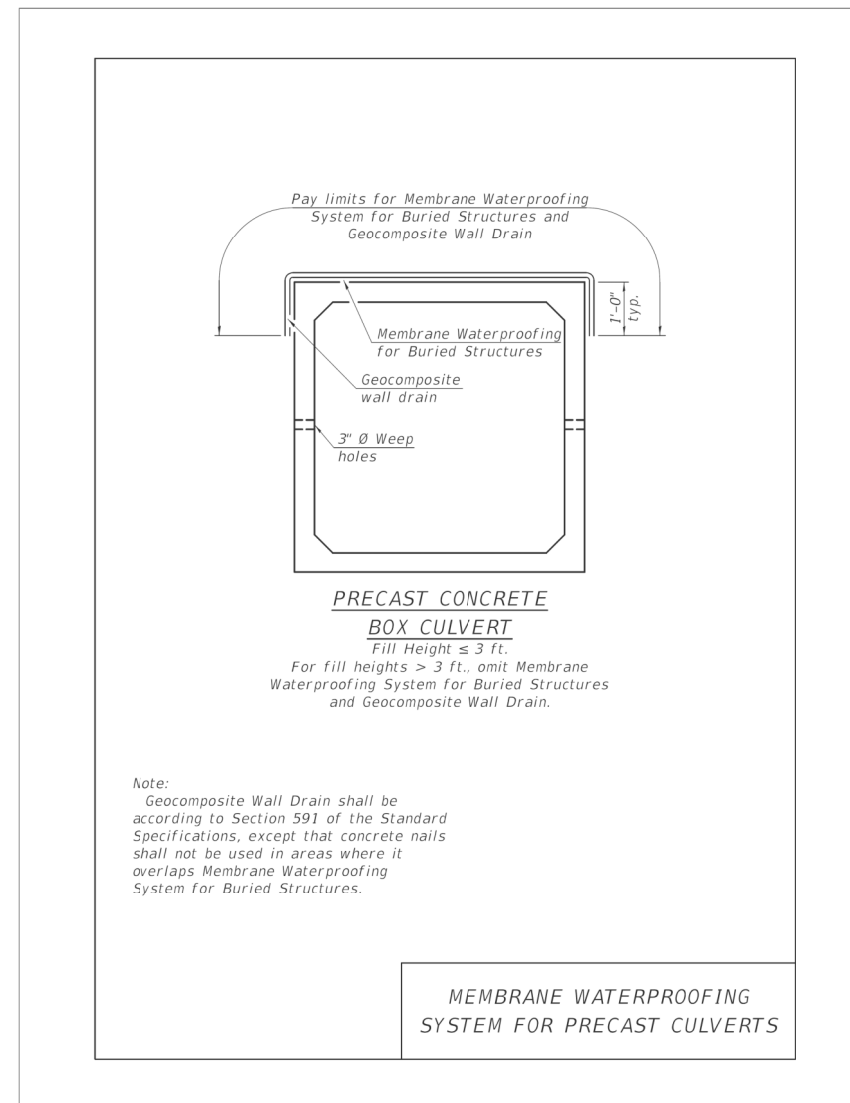
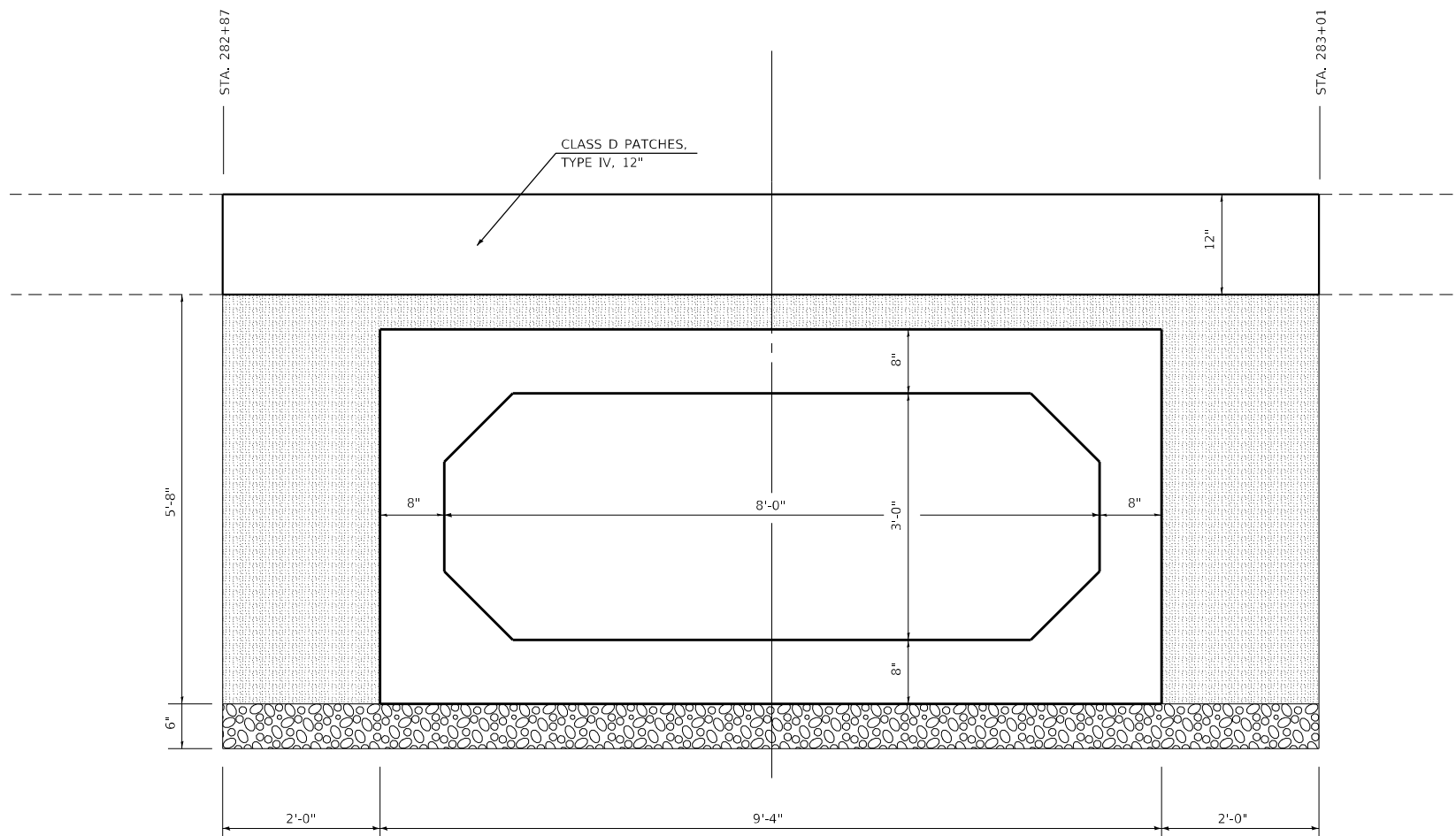

POROUS GRANULAR EMBANKMENT SHALL EXTEND 2 FT. BEYOND THE AGGREGATE SHOULDER.

THE WORK SHOWN IN THIS DETAIL SHALL BE PERFORMED IN ACCORDANCE WITH THE APPLICABLE PORTIONS OF ARTICLE 207 AND ARTICLE 540 OF THE STANDARD SPECIFICATIONS.

THIS WORK SHALL BE PAID FOR AT THE CONTRACT UNIT PRICE PER CUBIC YARD OF POROUS GRANULAR EMBANKMENT.

THE AREA TO BE EXCAVATED FOR THE PROPOSED BOX CULVERT SHALL NOT BE MEASURED FOR PAYMENT. THE COST OF THE EXCAVATION SHALL BE INCLUDED IN THE COST OF PRECAST CONCRETE BOX CULVERTS AND PRECAST CONCRETE BOX CULVERT END SECTIONS.

Note:
Geocomposite Wall Drain shall be according to Section 591 of the Standard Specifications, except that concrete nails shall not be used in areas where it overlaps Membrane Waterproofing System for Buried Structures.

BILL OF MATERIAL

ITEM	UNIT	TOTAL
Porous Granular Embankment	Cu. Yd.	37.0
Geocomposite Wall Drain	Sq. Yd.	53.0
Membrane Waterproofing System for Buried Structures	Sq. Yd.	53.0

MODEL NUMBER: MAM16
FILE NAME: B11E15

USER NAME = SUSERS	DESIGNED -	REVISED -
	DRAWN -	REVISED -
PLOT SCALE = SCALES	CHECKED -	REVISED -
PLOT DATE = SDATES	DATE -	REVISED -

**STATE OF ILLINOIS
DEPARTMENT OF TRANSPORTATION**

**POROUS GRANULAR EMBANKMENT DETAILS
S.N. 012-8658**

SCALE: SHEET 4 OF 4 SHEETS STA. TO STA.

F.A.P. RTE.	SECTION	COUNTY	TOTAL SHEETS	SHEET NO.
832	(113.114)RS-4	CLARK	46	27
ILLINOIS FED. AID PROJECT			CONTRACT NO. 74945	

SN. 012-0061 carries ILL 49 (FAP 832) over a tributary to Lamb Branch. The existing single span, steel beam bridge with integral abutments was constructed in 1984. The proposed project consists of bridge deck scarification, deck patching, bridge deck overlay, and new approach slabs.

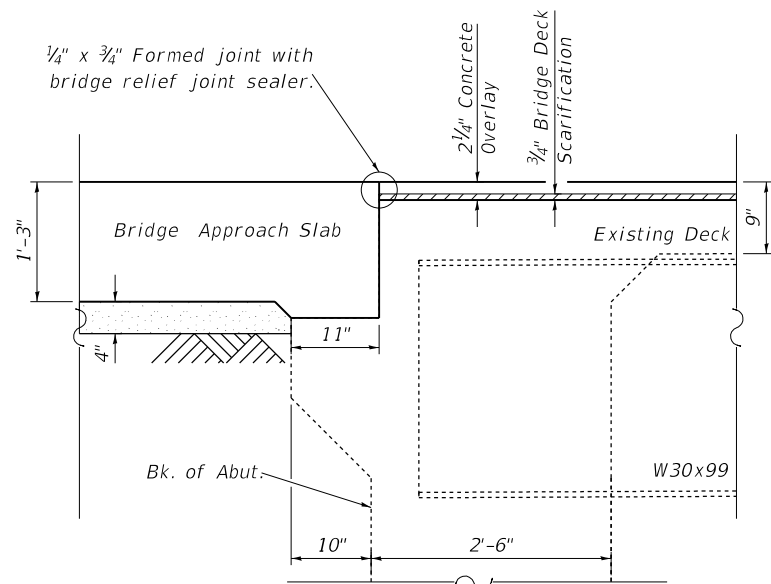

SECTION A-A

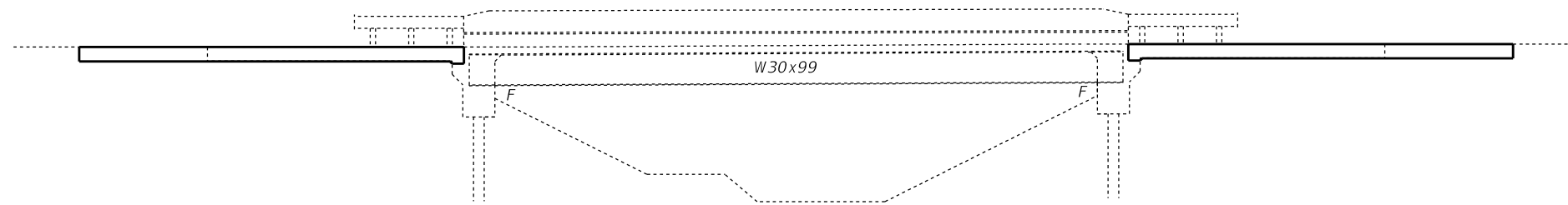

ELEVATION

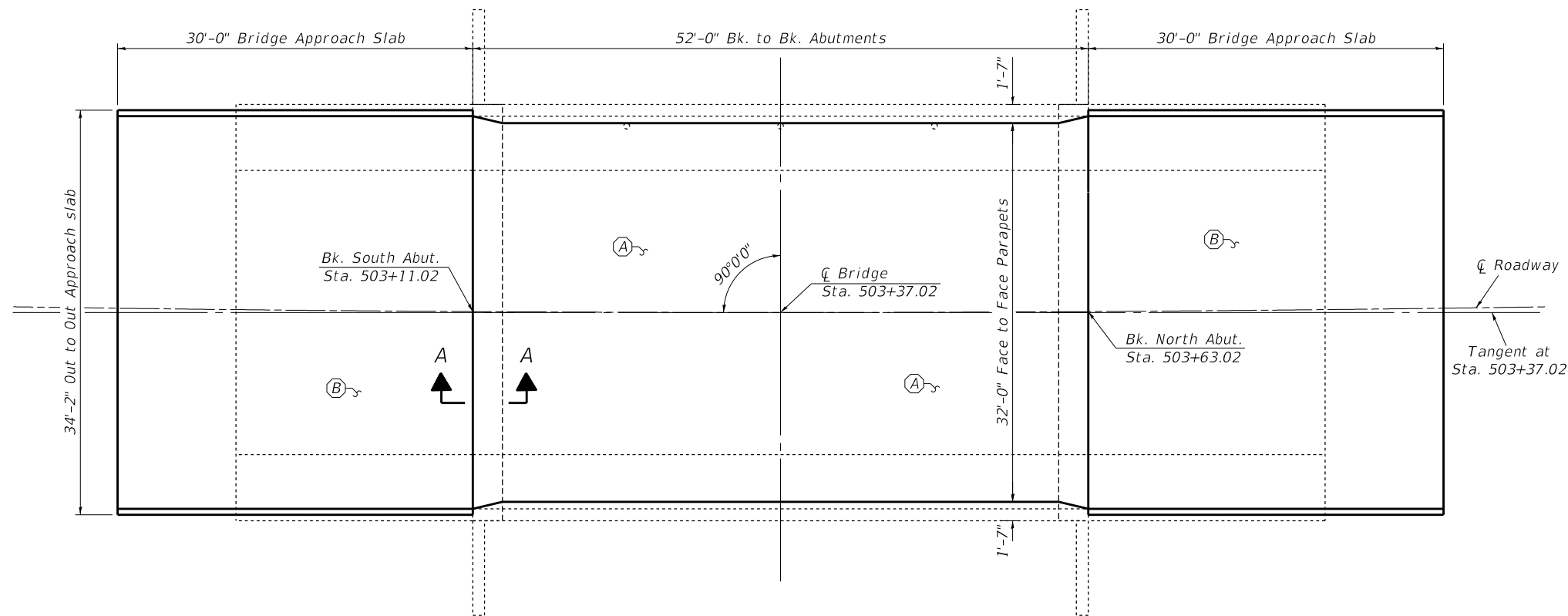

PLAN

- (A) - Bridge Deck Scarification, 3/4", Deck Slab Repair, & Bridge Deck Fly Ash or GGBF Slag Concrete Overlay, 2-1/4"
- (B) - Remove & Replace Bridge Approach Slab



Expires 11-30-2022

David Carl Puzey

01/26/2021

MODEL: Default
FILE: A:\mfc_p\pub\barroom.dwg
PROJECT: 74945
CADD: DataCAD
SHEETS: D774945-rlc-012-0061 & 0066 Repair Plans.dgn

USER NAME = Default	DESIGNED - T. Walk	REVISED -
	DRAWN - T. Walk	REVISED -
PLOT SCALE = 100.0000' / in.	CHECKED - D. Macklin	REVISED -
PLOT DATE = 1/5/2021	DATE - Sept. 2020	REVISED -

STATE OF ILLINOIS
DEPARTMENT OF TRANSPORTATION

GENERAL PLAN & ELEVATION
SN 012-0061

SCALE: SHEET 1 OF 6 SHEETS STA. TO STA.

F.A.P. RTE.	SECTION	COUNTY	TOTAL SHEETS	SHEET NO.
832	(113,114)RS-4	CLARK	46	28
CONTRACT NO. 74945				
ILLINOIS FED. AID PROJECT				

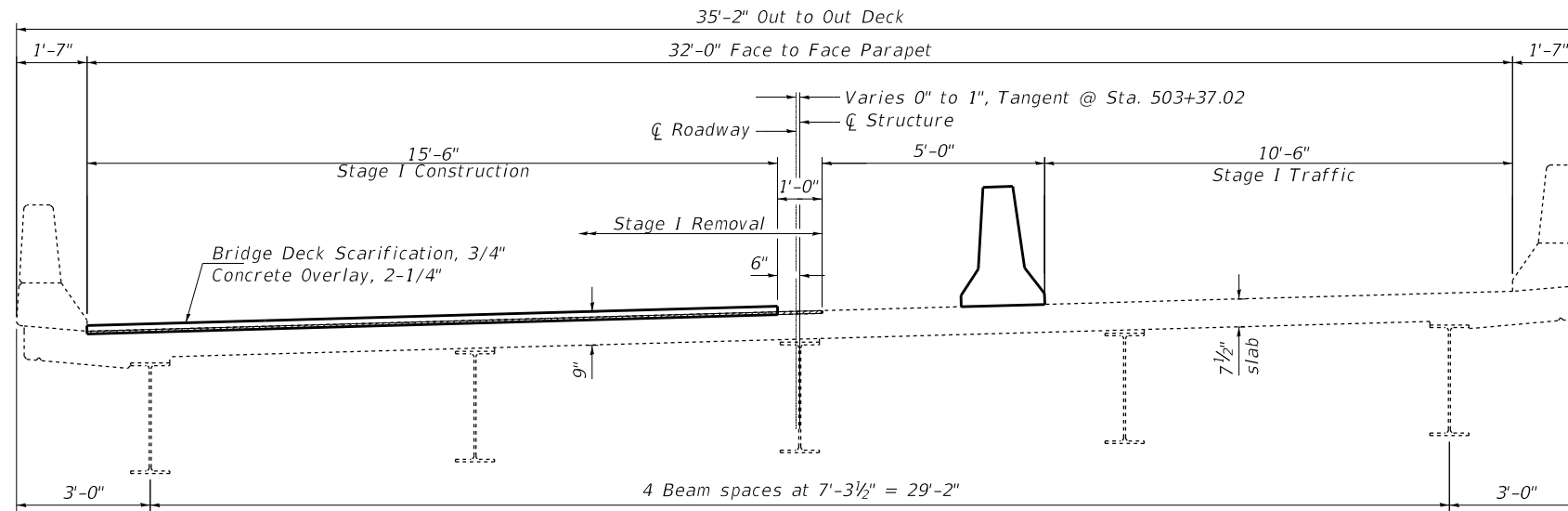

STAGE I
Looking North

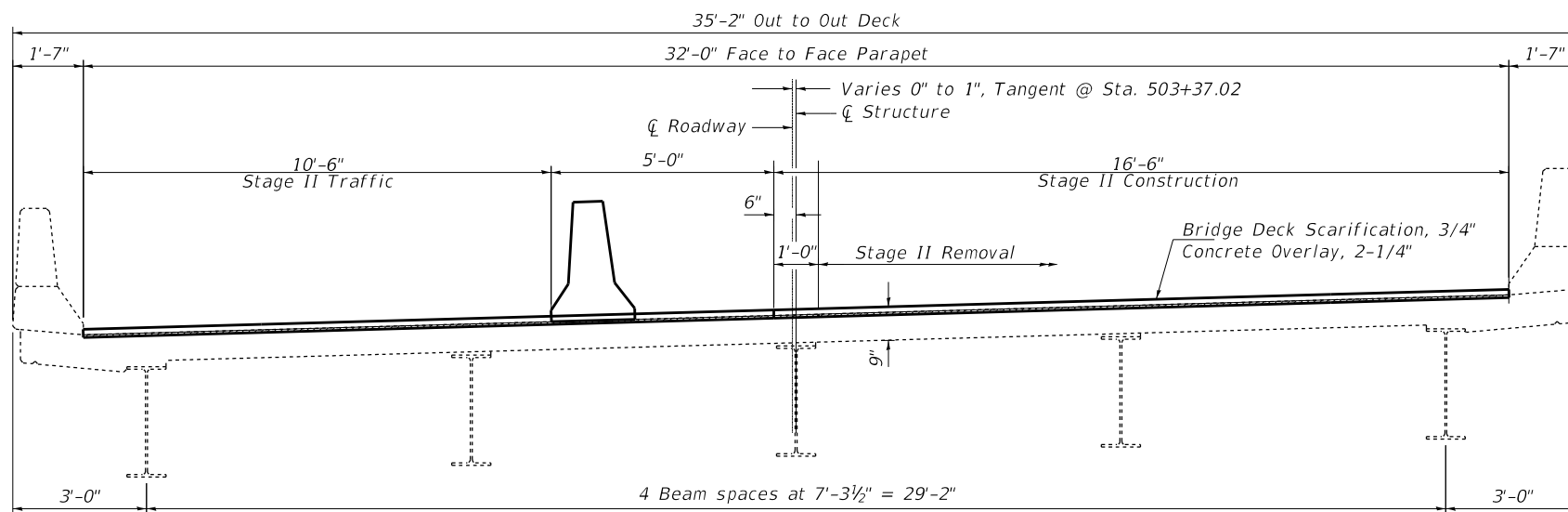

STAGE II
Looking North

GENERAL NOTES

Plan dimensions and details relative to existing plans are subject to nominal construction variations. The Contractor shall field verify existing dimensions and details affecting new construction and make necessary approved adjustments prior to construction or ordering of materials. Such variations shall not be cause for additional compensation for a change in scope of the work, however, the Contractor will be paid for the quantity actually furnished at the unit price bid for the work.

Reinforcement Bars designated (E) shall be epoxy coated.

Protective Coat to be applied to areas of new concrete only, including bridge deck concrete overlay.

Areas of deck repairs shown are estimated. The Engineer shall show actual locations of deck repairs on as-built plans.

TOTAL BILL OF MATERIALS

ITEM	UNIT	QUANTITY
Bridge Deck Fly Ash or GGBF Concrete Overlay, 2-1/4"	Sq. Yd.	186
Deck Slab Repair (Full Depth, Type I)	Sq. Yd.	2.0
Deck Slab Repair (Full Depth, Type II)	Sq. Yd.	2.0
Bridge Deck Scarification, 3/4"	Sq. Yd.	186
Bridge Deck Grooving	Sq. Yd.	381
Protective Coat	Sq. Yd.	417
Concrete Superstructure (Approach Slab)	Cu. Yd.	95.8
Concrete Structures	Cu. Yd.	21.2
Reinforcement Bars, Epoxy Coated	Pound	37,850
Bar Splicers	Each	290

MODEL: Default
 FILE: \\blm01c-prod\pub\aroom.dwg
 PROJECT: 74945-SPR-012-0061 & 0066 Repair Plans.dwg
 OFFICE: IDOT - Office of District 7
 DATE: 1/5/2021

USER NAME = Default	DESIGNED - T. Walk	REVISED -
	DRAWN - T. Walk	REVISED -
PLOT SCALE = 100.0000 ' / in.	CHECKED - D. Macklin	REVISED -
PLOT DATE = 1/5/2021	DATE - Sept. 2020	REVISED -

**STATE OF ILLINOIS
DEPARTMENT OF TRANSPORTATION**

**STAGE CONSTRUCTION DETAILS, GENERAL NOTES,
& BILL OF MATERIALS SN 012-0061**

SCALE: SHEET 2 OF 6 SHEETS STA. TO STA.

F.A.P. RTE.	SECTION	COUNTY	TOTAL SHEETS	SHEET NO.
832	(113,114)RS-4	CLARK	46	29
CONTRACT NO. 74945				
ILLINOIS FED. AID PROJECT				

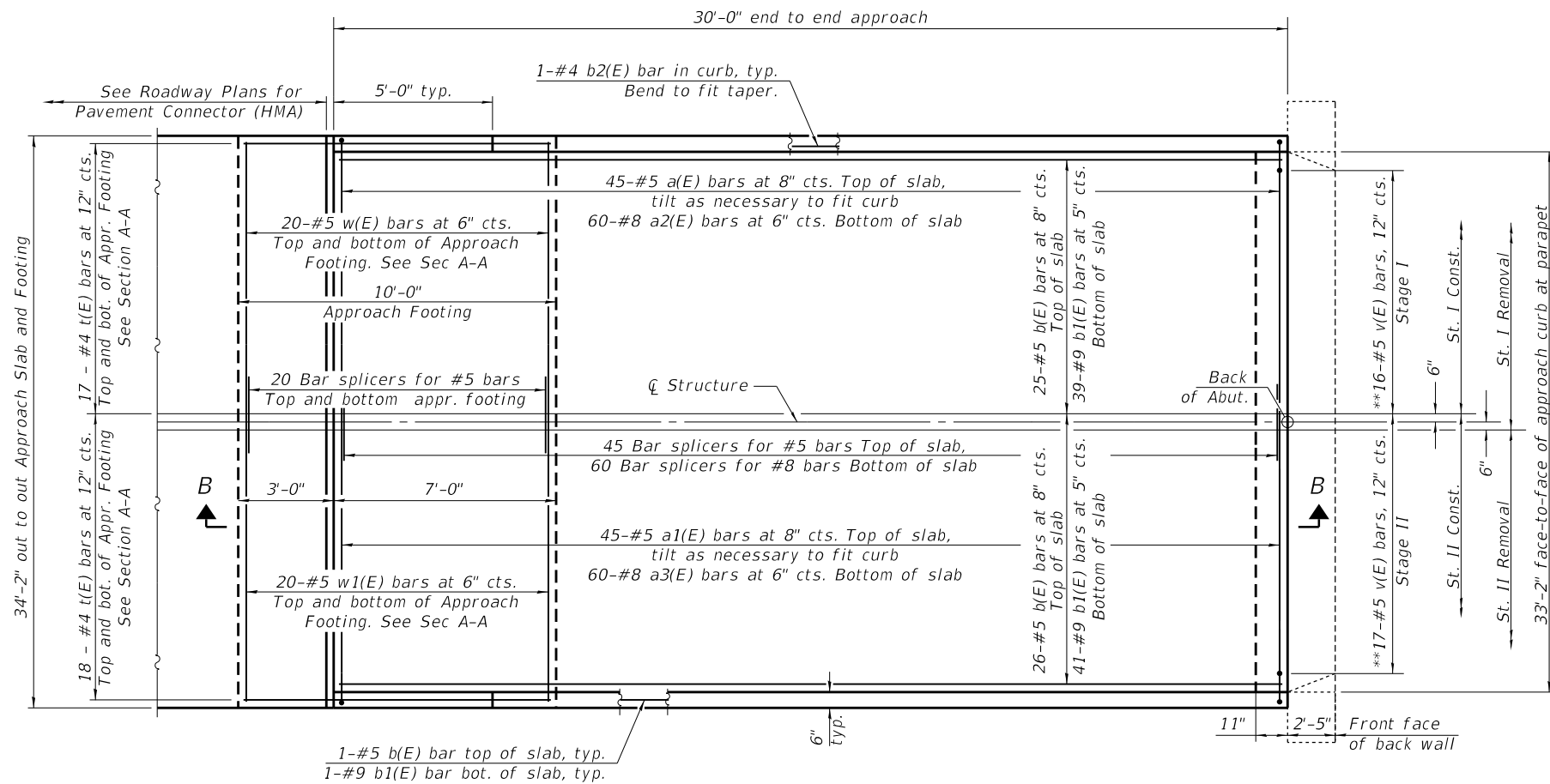

** Epoxy grout v(E) bars in 9" min. holes according to Article 584 of the Standard Specifications.

PLAN

South Approach Shown
North Approach Similar

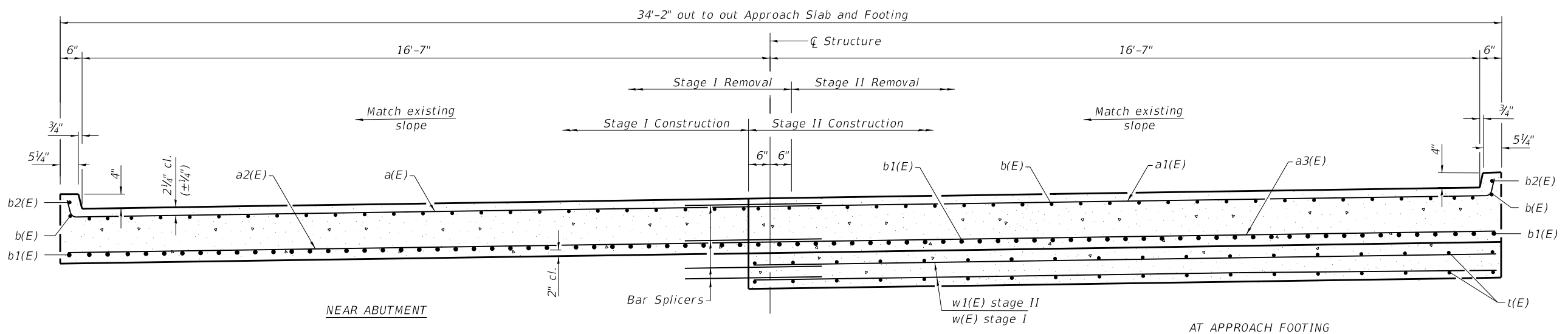

CROSS SECTION

Looking North

MODEL: Default
 FILE: Abutment_Plan.dwg
 PROJECT: 74945
 OFFICE: IDOT
 DRAWING: 74945-012-0061 & 0066 Repair Plans.dwg

USER NAME = Default	DESIGNED - D. Macklin	REVISED -
	DRAWN - D. Macklin	REVISED -
PLOT SCALE = 100,0000' / in.	CHECKED - T. Walk	REVISED -
PLOT DATE = 1/5/2021	DATE - Sept. 2020	REVISED -

**STATE OF ILLINOIS
DEPARTMENT OF TRANSPORTATION**

**BRIDGE APPROACH SLAB DETAILS - SHEET 1 OF 2
STRUCTURE NO. 012-0061**

SCALE: SHEET 4 OF 6 SHEETS STA. TO STA.

F.A.P. RTE. 832	SECTION (113,114) RS-4	COUNTY CLARK	TOTAL SHEETS 46	SHEET NO. 31
CONTRACT NO. 74945				
ILLINOIS FED. AID PROJECT				

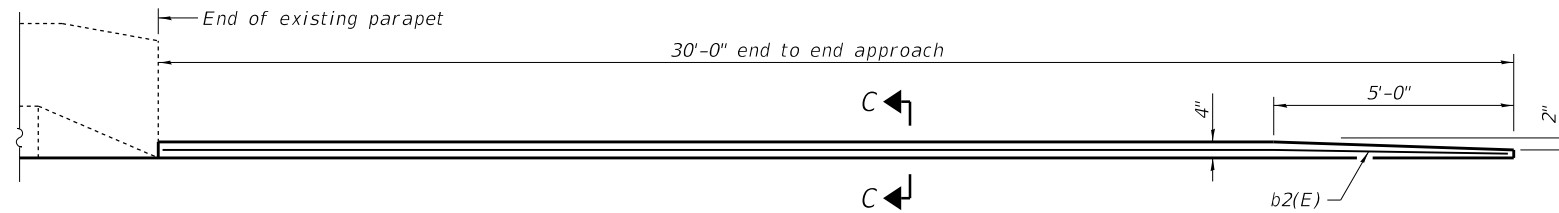

INSIDE ELEVATION OF CURB

Notes:
 Approach slab shall be paid for as Concrete Superstructure (Approach Slab).
 Approach footing concrete shall be paid for as Concrete Structures.
 The approach footing maximum applied service bearing pressure (Qmax) = 2.0 ksf.
 Cost of excavation for approach footing included with Concrete Structures.

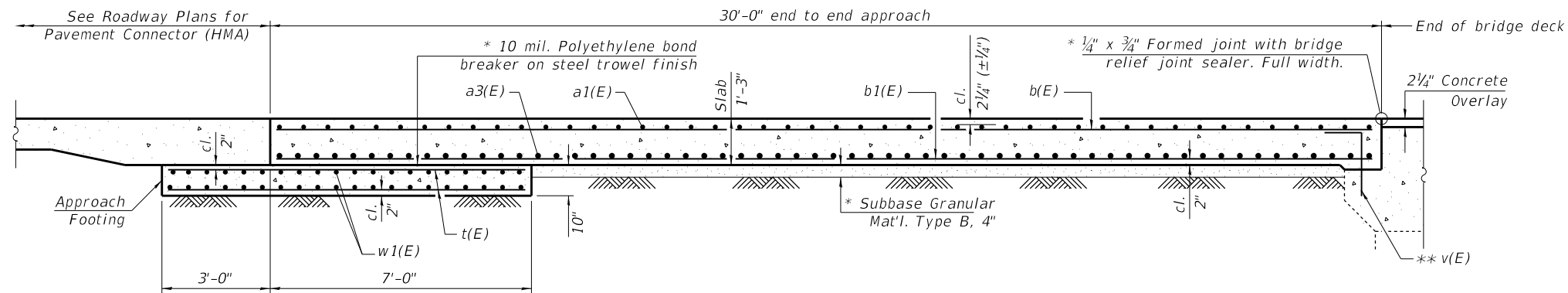

SECTION B-B

**TWO APPROACHES
 BILL OF MATERIAL**

Bar	No.	Size	Length	Shape	
a(E)	90	#5	16'-7"	—	
a1(E)	90	#5	17'-7"	—	
a2(E)	120	#8	16'-3"	—	
a3(E)	120	#8	17'-3"	—	
b(E)	106	#5	29'-8"	—	
b1(E)	164	#9	29'-8"	—	
b2(E)	4	#4	29'-8"	—	
t(E)	140	#4	9'-8"	—	
v(E)	66	#5	3'-10"	┌	
w(E)	80	#5	16'-3"	—	
w1(E)	80	#5	17'-3"	—	
Concrete Superstructure (Approach Slab)				Cu. Yd.	95.8
Concrete Structures				Cu. Yd.	21.2
Reinforcement Bars, Epoxy Coated				Pound	37,850
Bar Splicers				Each	290

* Cost included with Concrete Superstructure (Approach Slab).
 **Epoxy grout v(E) bars in 9" min. holes according to Article 584 of the Standard Specifications.

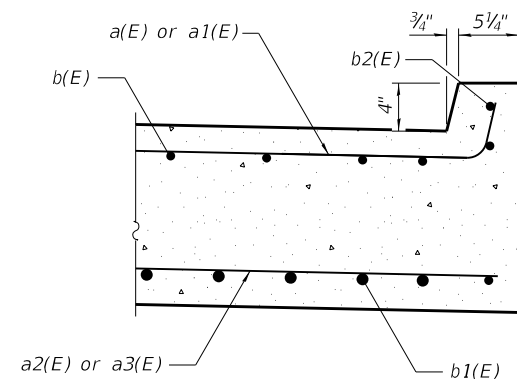

SECTION C-C

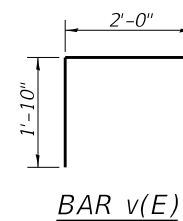

BAR v(E)

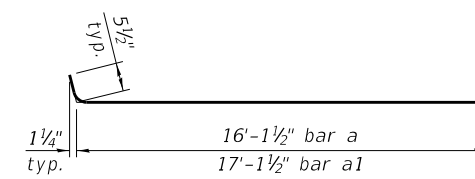

BARS a(E) & a1(E)

MODEL: Default
 FILE: Model: P:\pub\barroom.dwg
 PROJECT: 74945
 OFFICE: 74945
 DRAWING: 74945-012-0061 & 0066 Repair Plans.dwg

USER NAME = Default	DESIGNED - D. Macklin	REVISED -
PLOT SCALE = 100,0000 ' / in.	DRAWN - D. Macklin	REVISED -
PLOT DATE = 1/5/2021	CHECKED - T. Walk	REVISED -
	DATE - Sept. 2020	REVISED -

**STATE OF ILLINOIS
 DEPARTMENT OF TRANSPORTATION**

**BRIDGE APPROACH SLAB DETAILS - SHEET 2 OF 2
 STRUCTURE NO. 012-0061**

SCALE: SHEET 5 OF 6 SHEETS STA. TO STA.

F.A.P. RTE.	SECTION	COUNTY	TOTAL SHEETS	SHEET NO.
832	(113,114) RS-4	CLARK	46	32
CONTRACT NO. 74945				
ILLINOIS FED. AID PROJECT				

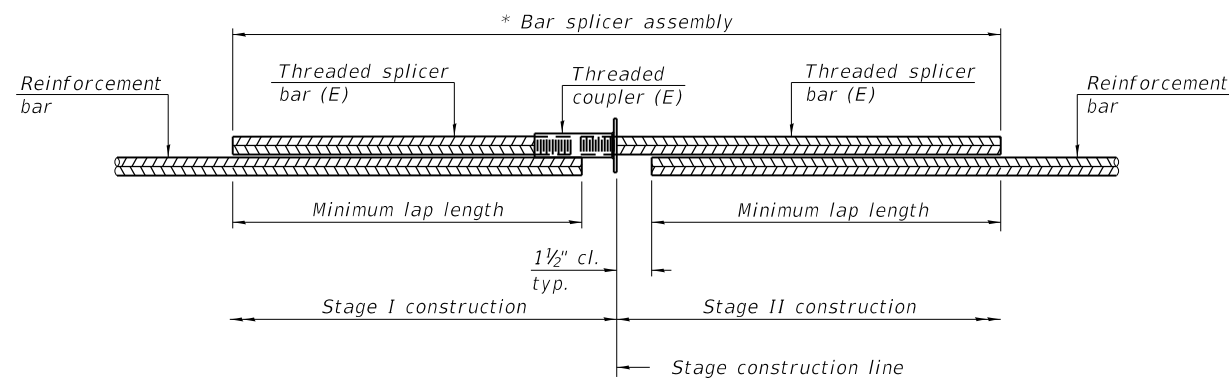

STANDARD BAR SPLICER ASSEMBLY PLAN
 (All components shall be provided from one supplier)

Threaded splicer bar length = min. lap length + 1 1/2" + thread length

* Epoxy not required on Bar Splicer Assembly components used in conjunction with black bars.

Location	Bar size	No. assemblies required	Minimum lap length
Approach	#5	170	3'-0"
Approach	#8	120	4'-9"

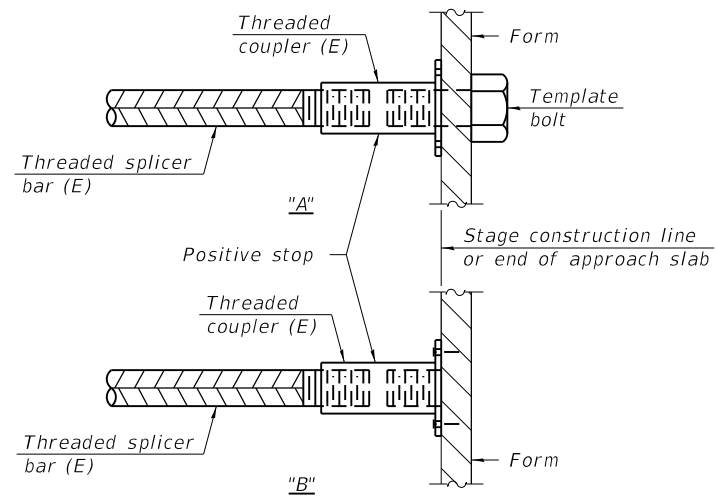

INSTALLATION AND SETTING METHODS

"A" : Set bar splicer assembly by means of a template bolt.

"B" : Set bar splicer assembly by nailing to wood forms or cementing to steel forms.

(E) : Indicates epoxy coating.

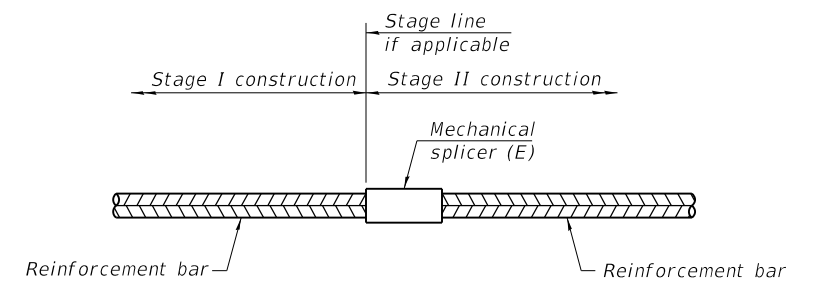

STANDARD MECHANICAL SPLICER

Location	Bar size	No. assemblies required

Notes:

Splicer bars shall be deformed with threaded ends and have a minimum 60 ksi yield strength.

All reinforcement shall be lapped and tied to the splicer bars.

Bar splicer assemblies shall be epoxy coated according to the requirements for reinforcement bars. See Section 508 of the Standard Specifications.

See approved list of bar splicer assemblies and mechanical splicers for alternatives.

MODEL: Default
 FILE: \\blm1c1\pub\barroom.dwg
 PROJECT: 74945\CADD\Drawings\DOT_Offices\Drawings\74945-Sub-C12-0061 & 0066 Repair Plans.dwg

BSD-1

1-1-2020

USER NAME = Default	DESIGNED - T. Walk	REVISED -
	DRAWN - T. Walk	REVISED -
PLOT SCALE = 100,0000' / in.	CHECKED - D. Macklin	REVISED -
PLOT DATE = 1/5/2021	DATE - Sept. 2020	REVISED -

**STATE OF ILLINOIS
 DEPARTMENT OF TRANSPORTATION**

**BAR SPLICER ASSEMBLY AND MECHANICAL SPLICER DETAILS
 STRUCTURE NO. 012-0061**

SCALE: SHEET 6 OF 6 SHEETS STA. TO STA.

F.A.P. RTE.	SECTION	COUNTY	TOTAL SHEETS	SHEET NO.
832	(113,114) RS-4	CLARK	46	33
CONTRACT NO. 74945				
ILLINOIS FED. AID PROJECT				

SN. 012-0066 carries ILL 49 (FAP 832) over the West Fork of Embarras River. The existing single span, Bulb-T beam structure with closed abutments was constructed in 1994. The proposed project consists of bridge deck scarification, deck patching, bridge deck overlay.

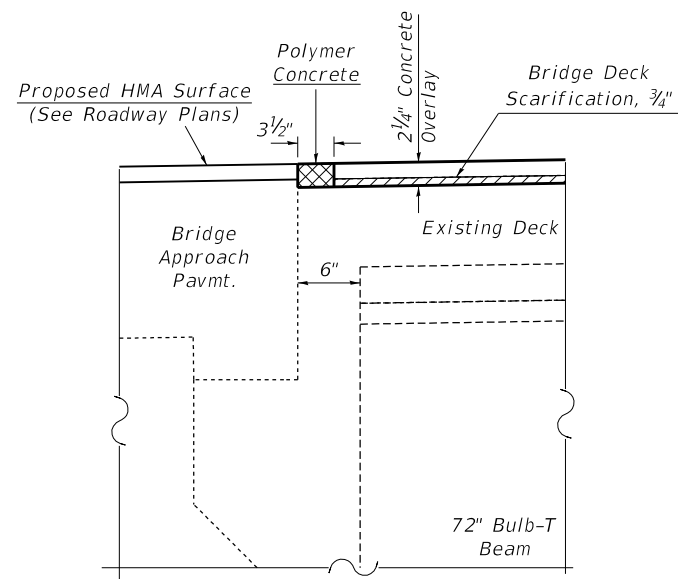

SECTION A-A

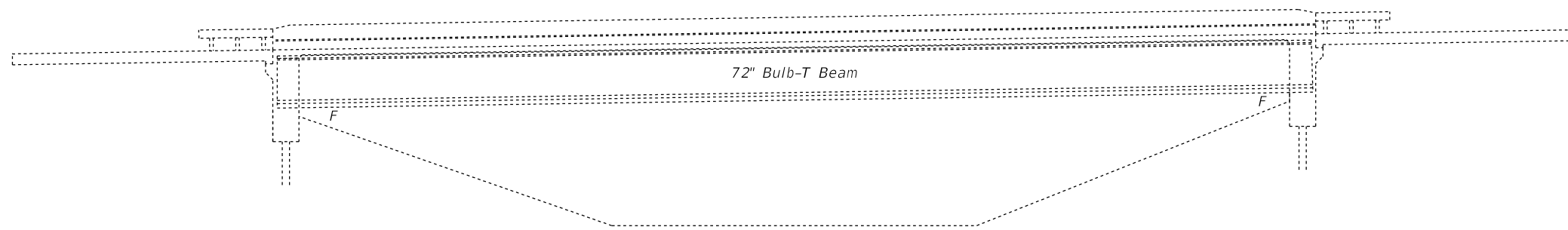

ELEVATION

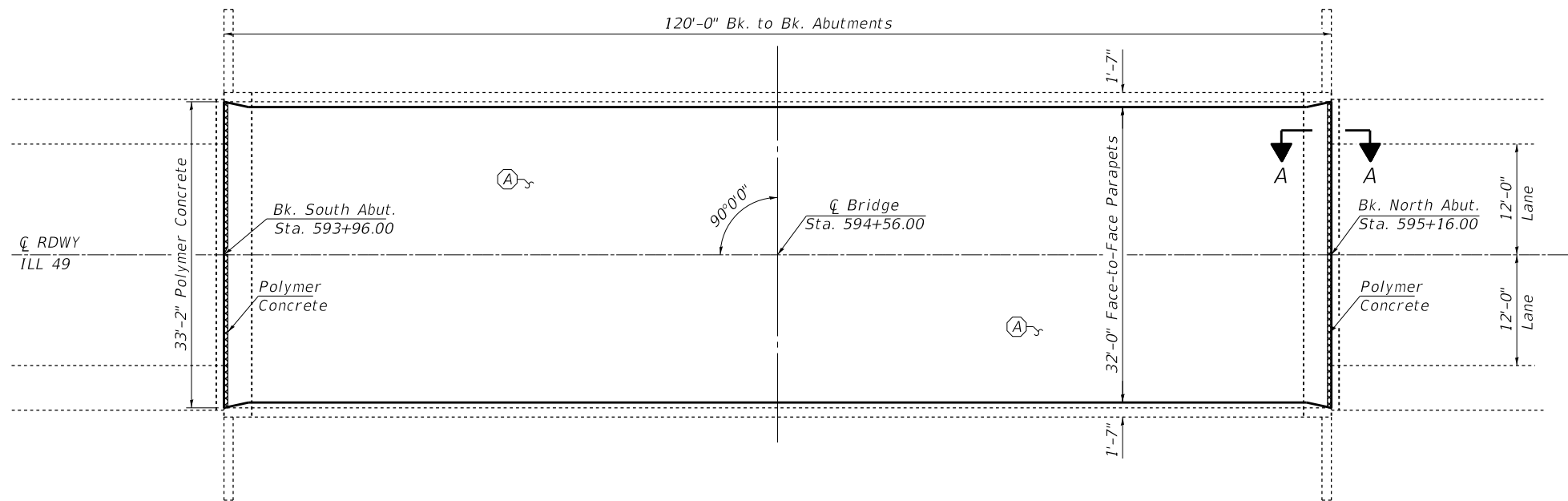

PLAN

(A) - Bridge Deck Scarification, 3/4", Patching, & Bridge Deck Fly Ash or GGBF Slag Concrete Overlay, 2-1/4"



Expires 11-30-2022

David Carl Puzye

01/26/2021

MODEL: Default
FILE: \\nas01c.pw.us\pub\baronm.d\at\illink\pwr\PROJECTS\DOT\Documents\DOT_Offices\Illin\74945-RS-4\12-0061 & 0066 Repair Plans.dgn

USER NAME = Default	DESIGNED - T. Walk	REVISED -
	DRAWN - T. Walk	REVISED -
PLOT SCALE = 100.0000' / in.	CHECKED - D. Macklin	REVISED -
PLOT DATE = 1/5/2021	DATE - Sept. 2020	REVISED -

STATE OF ILLINOIS
DEPARTMENT OF TRANSPORTATION

GENERAL PLAN & ELEVATION
SN 012-0066

SCALE: SHEET 1 OF 3 SHEETS STA. TO STA.

F.A.P. RTE.	SECTION	COUNTY	TOTAL SHEETS	SHEET NO.
832	(113,114)RS-4	CLARK	46	34
CONTRACT NO. 74945				
ILLINOIS FED. AID PROJECT				

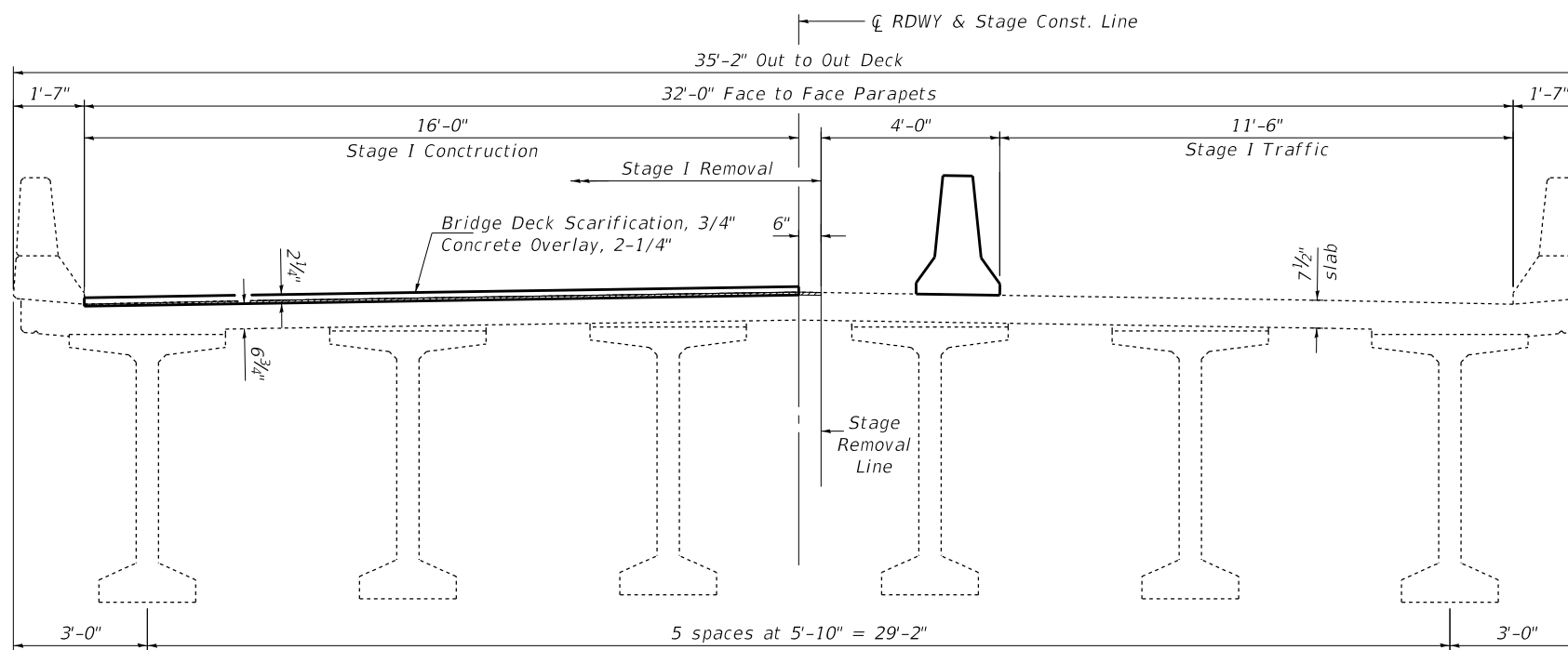

STAGE I
Looking North

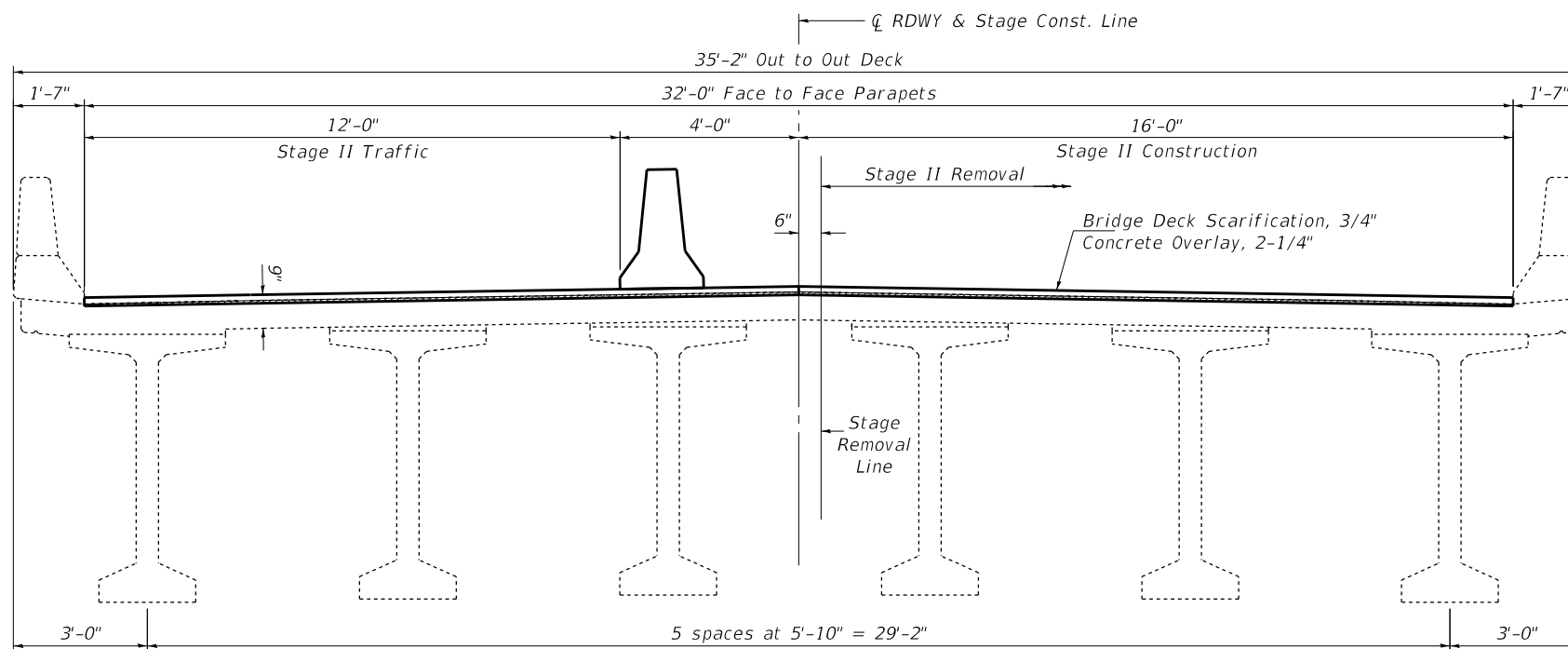

STAGE II
Looking North

GENERAL NOTES

Plan dimensions and details relative to existing plans are subject to nominal construction variations. The Contractor shall field verify existing dimensions and details affecting new construction and make necessary approved adjustments prior to construction or ordering of materials. Such variations shall not be cause for additional compensation for a change in scope of the work, however, the Contractor will be paid for the quantity actually furnished at the unit price bid for the work.

Protective Coat to be applied to areas of new concrete only, including bridge deck concrete overlay.

Areas of deck repairs shown are estimated. The Engineer shall show actual locations of deck repairs on as-built plans.

TOTAL BILL OF MATERIALS

ITEM	UNIT	QUANTITY
Bridge Deck Fly Ash or GGBF Concrete Overlay, 2-1/4"	Sq. Yd.	427
Deck Slab Repair (Full Depth, Type I)	Sq. Yd.	1.0
Bridge Deck Scarification, 3/4"	Sq. Yd.	427
Bridge Deck Grooving	Sq. Yd.	400
Protective Coat	Sq. Yd.	427
Polymer Concrete	Cu. Ft.	3.7

MODEL: Default
 FILE: \\blm01c.pw.us.ibm.com\data\blm01c.pw.us.ibm.com\projects\DOT\Documents\DOT_Offices\blm01c.pw.us.ibm.com\74945-012-0061 & 0066 Repair Plans.dgn

USER NAME = Default	DESIGNED - T. Walk	REVISED -
	DRAWN - T. Walk	REVISED -
PLOT SCALE = 100,0000' / in.	CHECKED - D. Macklin	REVISED -
PLOT DATE = 1/5/2021	DATE - Sept. 2020	REVISED -

**STATE OF ILLINOIS
DEPARTMENT OF TRANSPORTATION**

**STAGE CONSTRUCTION DETAILS, GENERAL NOTES,
& BILL OF MATERIAL SN 012-0066**

SCALE: SHEET 2 OF 3 SHEETS STA. TO STA.

F.A.P. RTE.	SECTION	COUNTY	TOTAL SHEETS	SHEET NO.
832	(113,114)RS-4	CLARK	46	35
CONTRACT NO. 74945				
ILLINOIS FED. AID PROJECT				

BUTT JOINT DETAILS

STA 90+82 TO STA 91+07
STA 656+36 TO STA 656+61

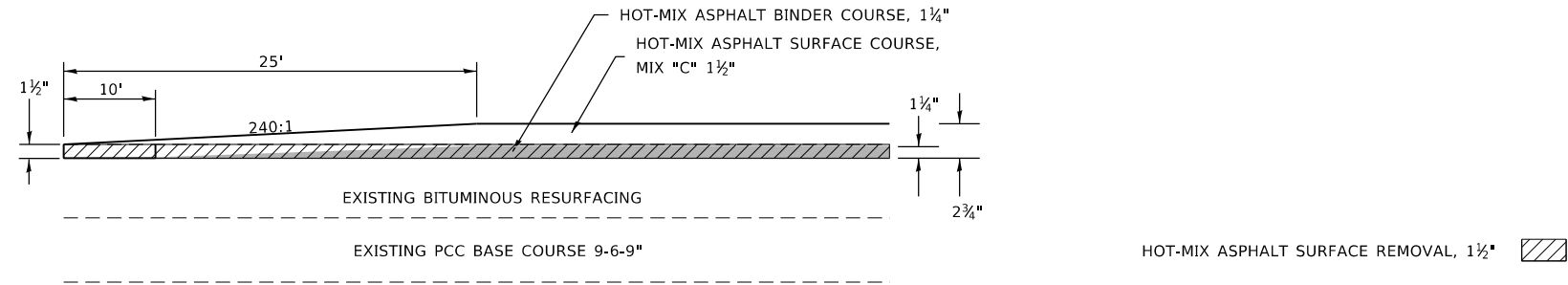

PROPOSED HMA SURFACE REMOVAL TRANSITION ILL 49 MAINLINE

(A)	TO	(B)
STATION		STATION
493+51		493+76
496+46		496+21
560+56		560+81
564+26		564+01

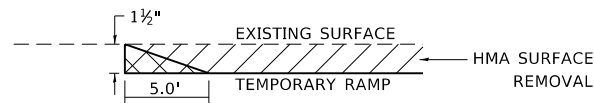
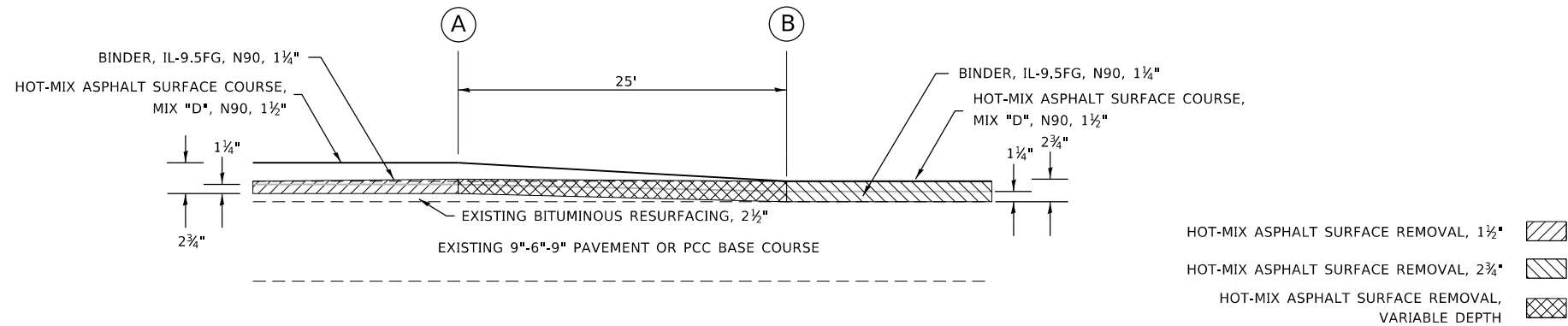

TEMPORARY RAMP

STA 90+82 TO STA 90+87
STA 502+86 TO STA 502+91
STA 503+83 TO STA 503+88
STA 593+61 TO STA 593+66
STA 595+46 TO STA 595+51
STA 656+56 TO STA 656+61



TEMPORARY RAMP

2000 RD
2120 RD (CLARKSVILLE RD)

NOT TO SCALE

MODEL: Default
FILE: \\nashville.pva\pub\baronson.dwg
PROJECT: \\nashville.pva\pub\baronson.dwg
OFFICE: \\nashville.pva\pub\baronson.dwg
DATE: 12/17/2020

USER NAME = steffemk	DESIGNED -	REVISED -
	DRAWN -	REVISED -
PLOT SCALE = 100.0000' / in.	CHECKED -	REVISED -
PLOT DATE = 12/17/2020	DATE -	REVISED -

STATE OF ILLINOIS
DEPARTMENT OF TRANSPORTATION

PAVING TRANSITION DETAILS

SCALE: SHEET 1 OF 2 SHEETS STA. TO STA.

F.A.P. RTE.	SECTION	COUNTY	TOTAL SHEETS	SHEET NO.
832	(113,114)RS-4	CLARK	46	37
CONTRACT NO. 74945			ILLINOIS FED. AID PROJECT	

HOT-MIX ASPHALT PROFILE GRADE CHANGE DETAIL

S.N. 012-0061

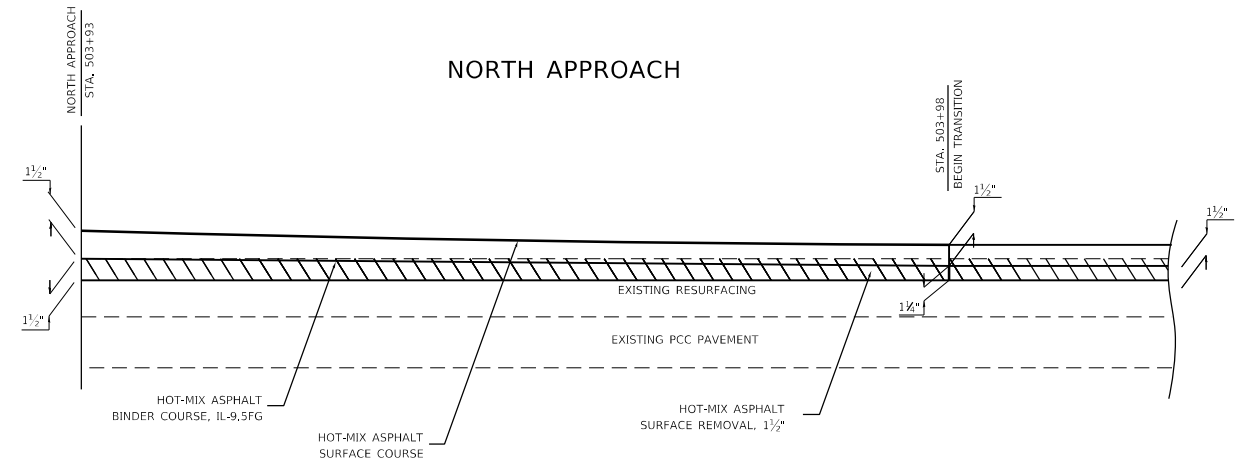
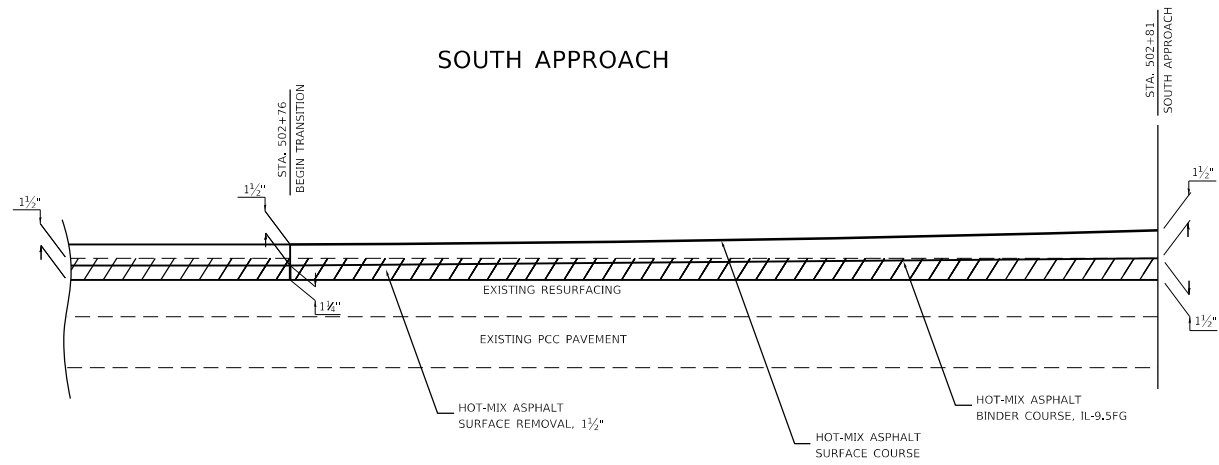

HOT-MIX ASPHALT PROFILE GRADE CHANGE DETAIL

S.N. 012-0066

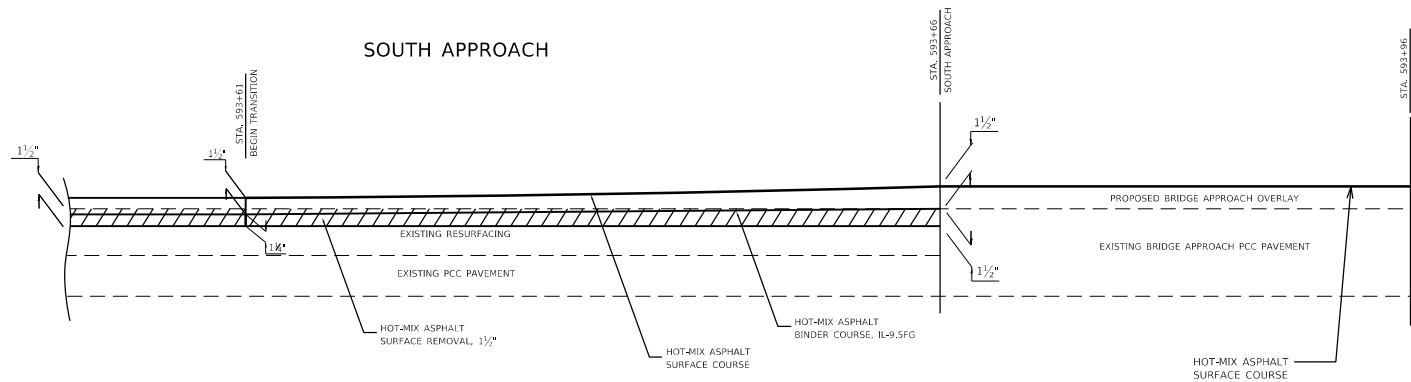

BRIDGE

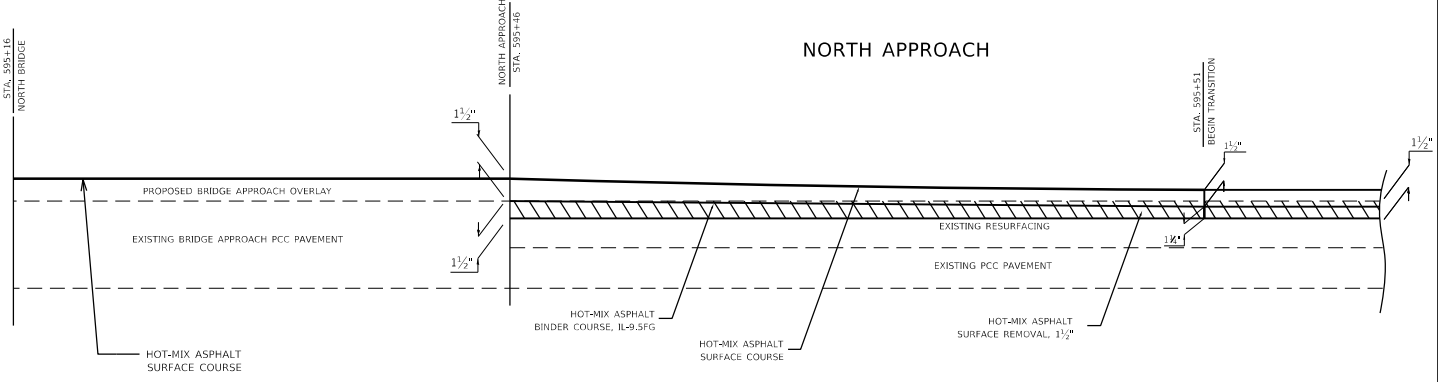

NOT TO SCALE

MODEL: Default
FILE: h:\mhc\pav\pavbarroom.dwg
PROJECT: 74945\CADD\Drawings\DOT_Offices\Drawings\74945-std\detail.dwg

USER NAME = steffenmk	DESIGNED -	REVISED -
	DRAWN -	REVISED -
PLOT SCALE = 100.0000' / in.	CHECKED -	REVISED -
PLOT DATE = 12/17/2020	DATE -	REVISED -

**STATE OF ILLINOIS
DEPARTMENT OF TRANSPORTATION**

PAVING TRANSITION DETAILS

SCALE: SHEET 2 OF 2 SHEETS STA. TO STA.

F.A.P. RTE.	SECTION	COUNTY	TOTAL SHEETS	SHEET NO.
832	(113,114)RS-4	CLARK	46	38
CONTRACT NO. 74945				
ILLINOIS FED. AID PROJECT				

TRANSITION DETAIL 4

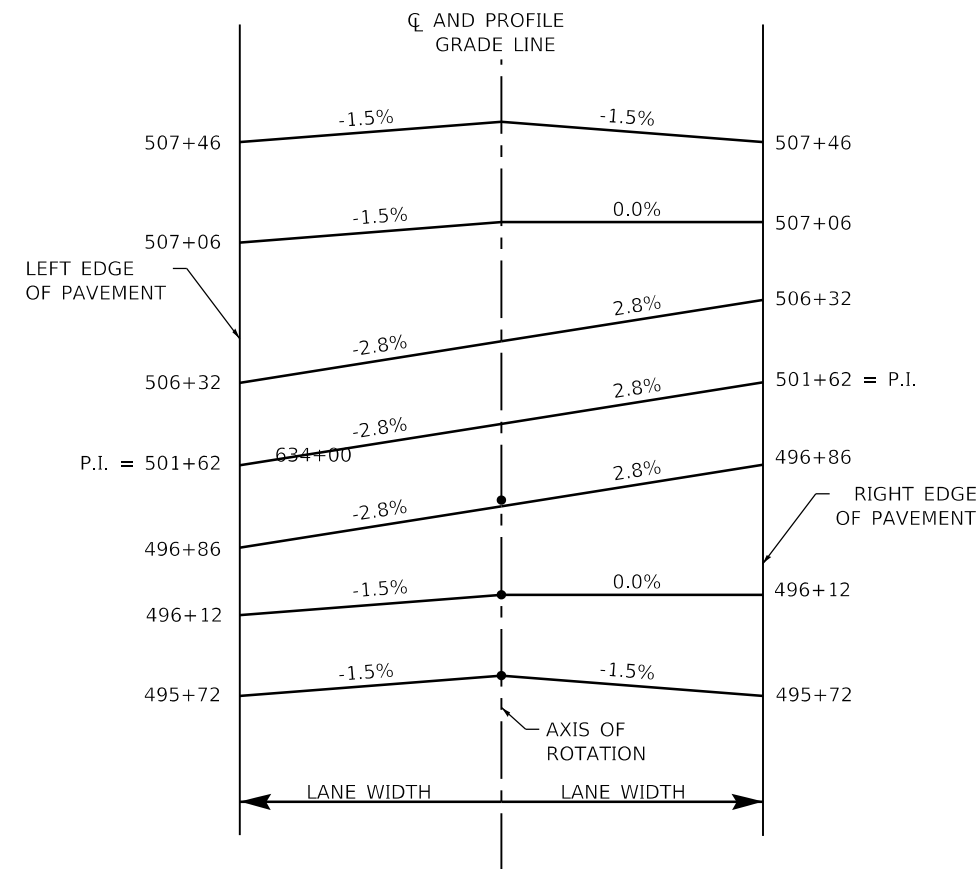

CURVE - PI STA 501+62

SEE PLAN AND PROFILE SHEETS FOR CURVE DATA

TRANSITION DETAIL 5

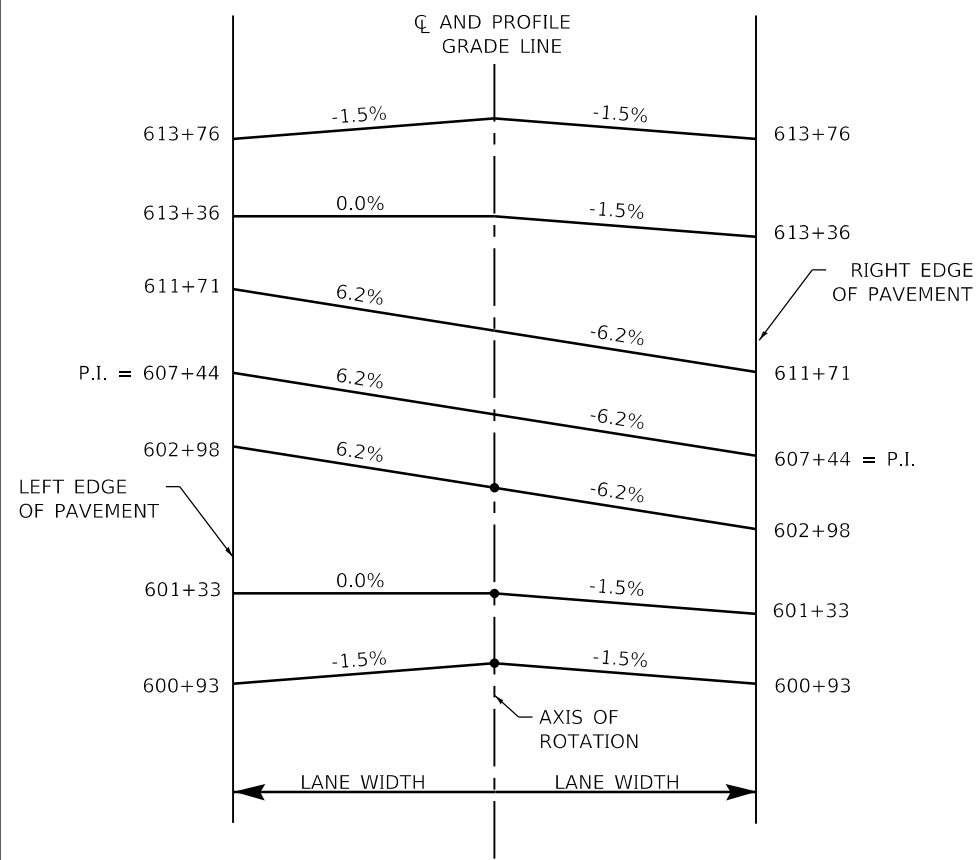

CURVE - PI STA 607+44

SEE PLAN AND PROFILE SHEETS FOR CURVE DATA

TRANSITION DETAIL 6

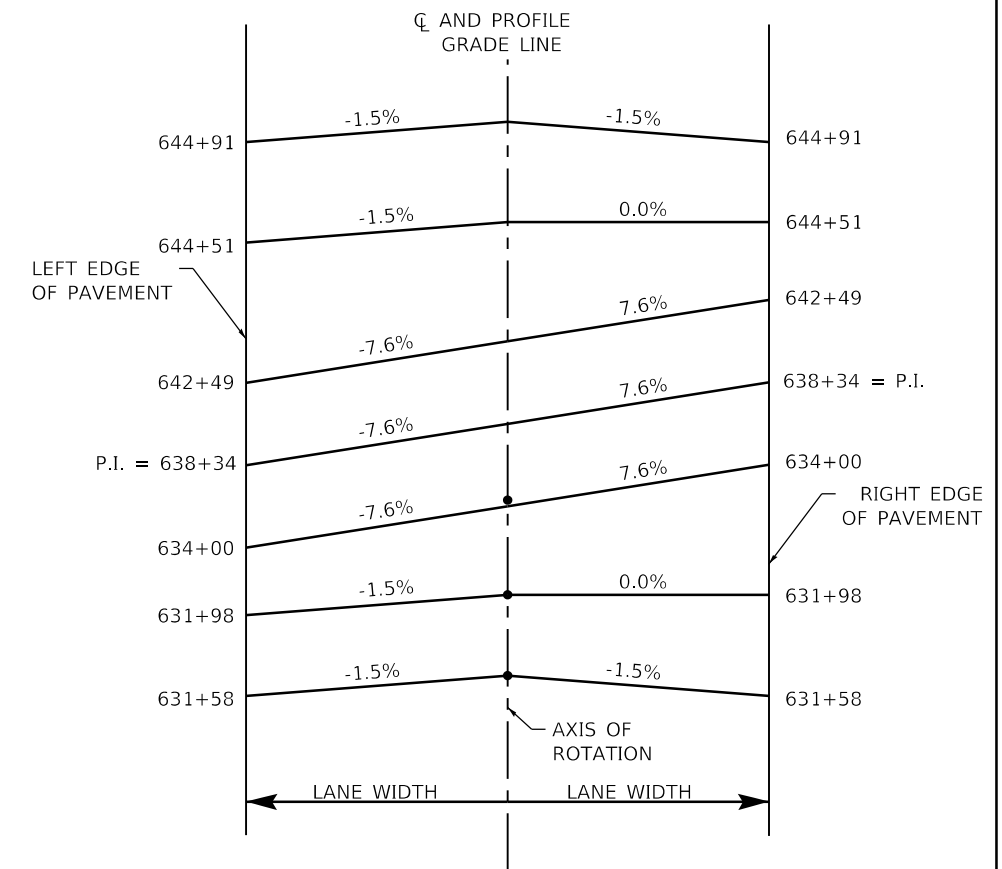

CURVE - PI STA 638+34

SEE PLAN AND PROFILE SHEETS FOR CURVE DATA

MODEL: Default
FILE: h:\a11\c:\p\pub\harcour\dat\illinois\p\p\p\DOT\Documents\DOT_Offices\Illinet\7\Projects\74945\CAAD\Drawings\DOT\Drawings\Sheet\74945-sht-dets4.dgn

USER NAME = steffemk	DESIGNED -	REVISED -
	DRAWN -	REVISED -
PLOT SCALE = 100.0000 ' / in.	CHECKED -	REVISED -
PLOT DATE = 12/17/2020	DATE -	REVISED -

**STATE OF ILLINOIS
DEPARTMENT OF TRANSPORTATION**

**SUPERELEVATION
TRANSITION DETAILS**

SCALE: SHEET 2 OF 2 SHEETS STA. TO STA.

F.A.P. RTE.	SECTION	COUNTY	TOTAL SHEETS	SHEET NO.
832	(113,114)RS-4	CLARK	46	40
CONTRACT NO. 74945				
ILLINOIS FED. AID PROJECT				

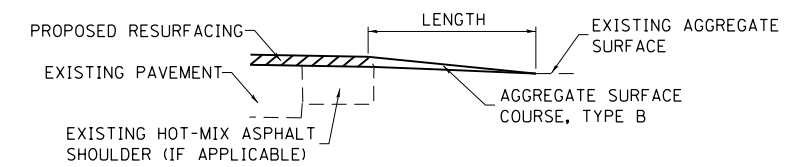
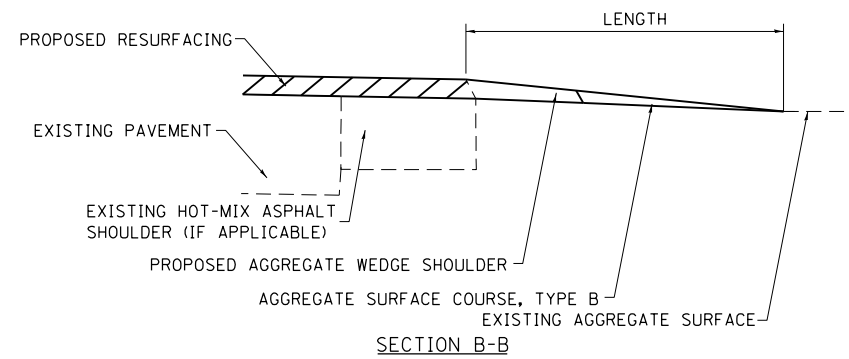
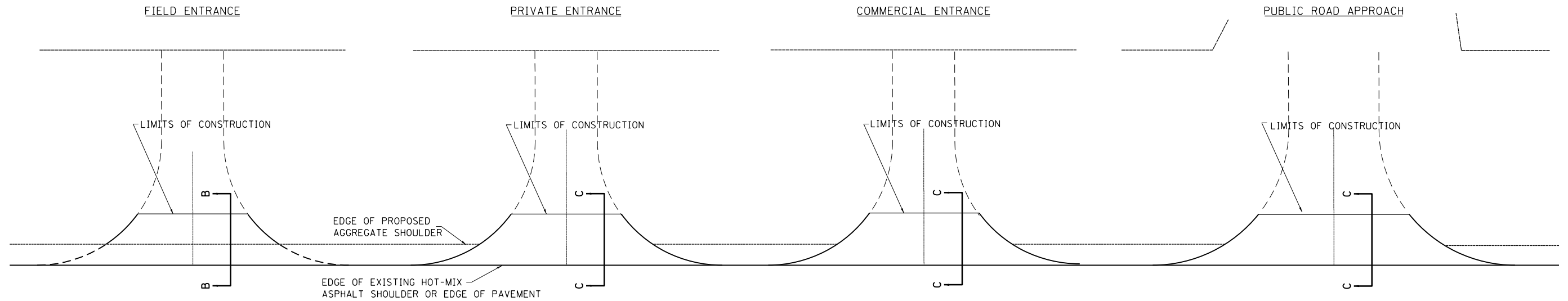

SECTION C-C

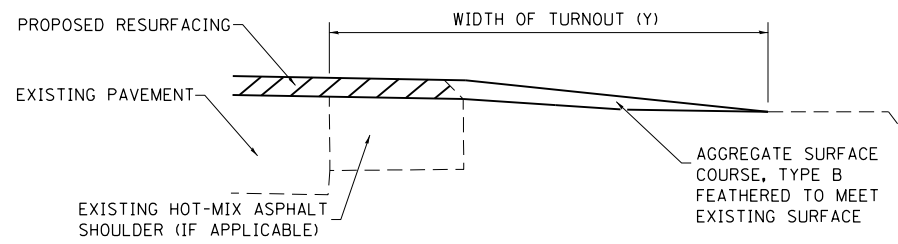

TYPICAL SECTION AT MAILBOX TURNOUT

NOTE: SEE STANDARD 406201 FOR MAILBOX TURNOUT DETAILS

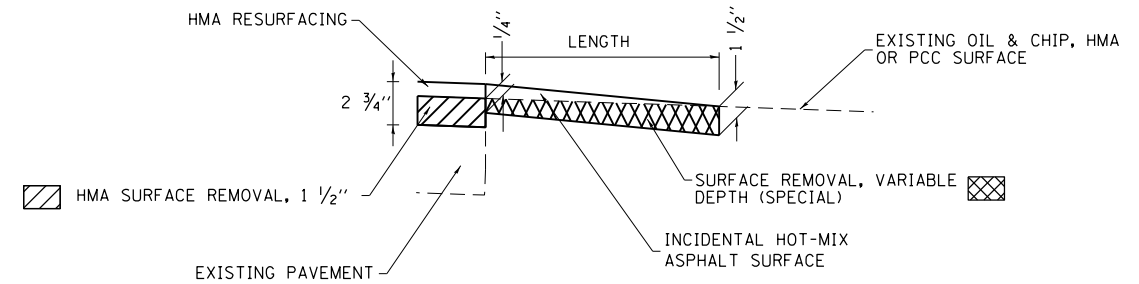

SECTION C-C

NOTES

LENGTH = 10' UNLESS OTHERWISE NOTED ON PLANS

IF THERE IS NOT EXISTING HOT-MIX ASPHALT SHOULDER THEN THE ENTRANCE TAPER STARTS AT THE EDGE OF EXISTING PAVEMENT.

MODEL: Default
 FILE: Mailbox_Plan_Spec.dwg
 PROJECT: 113.114RS-4
 SHEET: 46
 DATE: 12/17/2020

USER NAME = steffemk	DESIGNED -	REVISED -
	DRAWN -	REVISED -
PLOT SCALE = 100.0000' / in.	CHECKED -	REVISED -
PLOT DATE = 12/17/2020	DATE -	REVISED -

STATE OF ILLINOIS
DEPARTMENT OF TRANSPORTATION

RURAL ENTRANCE AND MAILBOX TURNOUT DETAILS
WITH SHOULDERS

SCALE: SHEET 1 OF 1 SHEETS STA. TO STA.

F.A.P. RTE. 832	SECTION (113.114)RS-4	COUNTY CLARK	TOTAL SHEETS 46	SHEET NO. 41
CONTRACT NO. 74945			ILLINOIS FED. AID PROJECT	

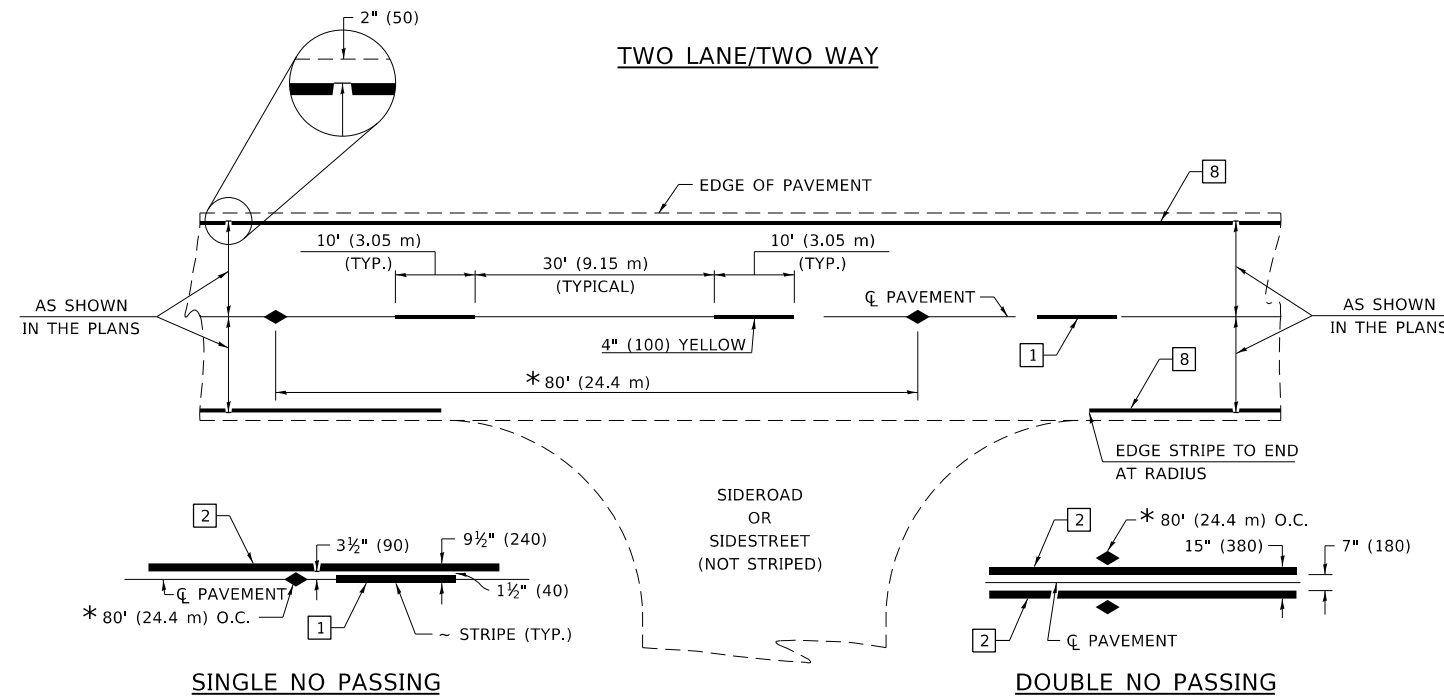

* REDUCE TO 40' (12.2 m) O.C. ON CURVES WITH POSTED OR ADVISORY SPEEDS OF 45 mph (70 km/h) OR LESS.

PAVEMENT MARKING LEGEND

- 1 4" (100) SKIP-DASH (YELLOW)
- 2 4" (100) SOLID (YELLOW)
- 3 12" (300) DIAGONAL (YELLOW)
- 4 4" (100) DOUBLE YELLOW (NARROW)
- 5 12" (300) SOLID WHITE
- 6 RESERVED
- 7 6" (150) SKIP-DASH (WHITE)
- 8 4" (100) SOLID (WHITE)
- 9 12" (300) DIAGONAL (WHITE)
- 10 6" (150) SOLID (WHITE)
- 11 24" (600) STOP BAR (WHITE)
- 12 8" (200) SOLID (WHITE)
- 13 4" (100) PARKING WHITE

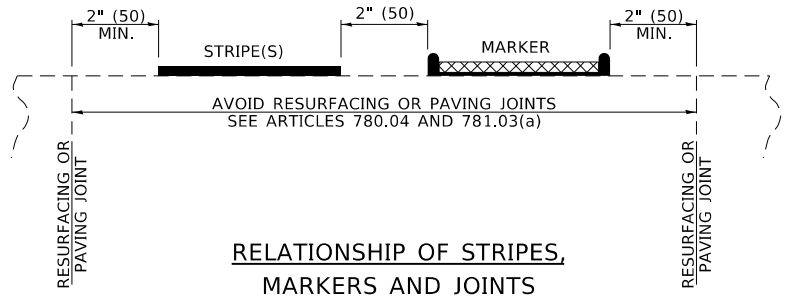

RELATIONSHIP OF STRIPES, MARKERS AND JOINTS

TYPICAL PAVEMENT MARKERS LEGEND

- ◆ TWO-WAY AMBER MARKER
- ▶ ONE-WAY AMBER MARKER
- ▷ ONE-WAY CRYSTAL MARKER

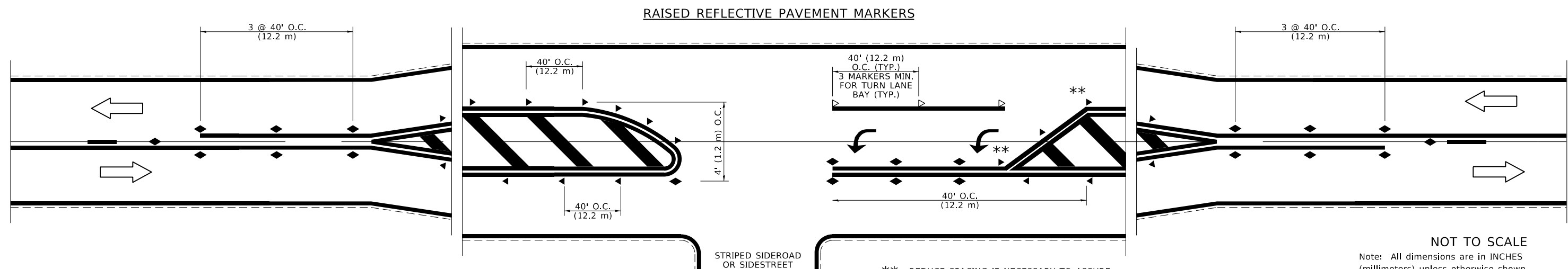

NOT TO SCALE
Note: All dimensions are in INCHES (millimeters) unless otherwise shown.

MODEL: Default
FILE: \\bls01\pub\baronon.dwg
PROJECT: 74945\CAD\Drawings\DOT - Office\Drawings\74945\Sheet\74945-std-drawings.dwg

USER NAME = steffenk	DESIGNED -	REVISED -
DRAWN -	REVISOR -	
PLOT SCALE = 100.0000 ' / in.	CHECKED -	REVISOR -
PLOT DATE = 12/17/2020	DATE -	REVISOR -

STATE OF ILLINOIS
DEPARTMENT OF TRANSPORTATION

PAVEMENT MARKING AND RAISED REFLECTIVE PAVEMENT MARKERS
(RURAL AND URBAN APPLICATIONS)

SCALE: SHEET 1 OF 4 SHEETS STA. TO STA.

DISTRICT 7 DETAIL NO. 7800001				
F.A.P. RTE.	SECTION	COUNTY	TOTAL SHEETS	SHEET NO.
832	(113,114)RS-4	CLARK	46	42
CONTRACT NO. 74945				
ILLINOIS FED. AID PROJECT				

URBAN LEFT TURN

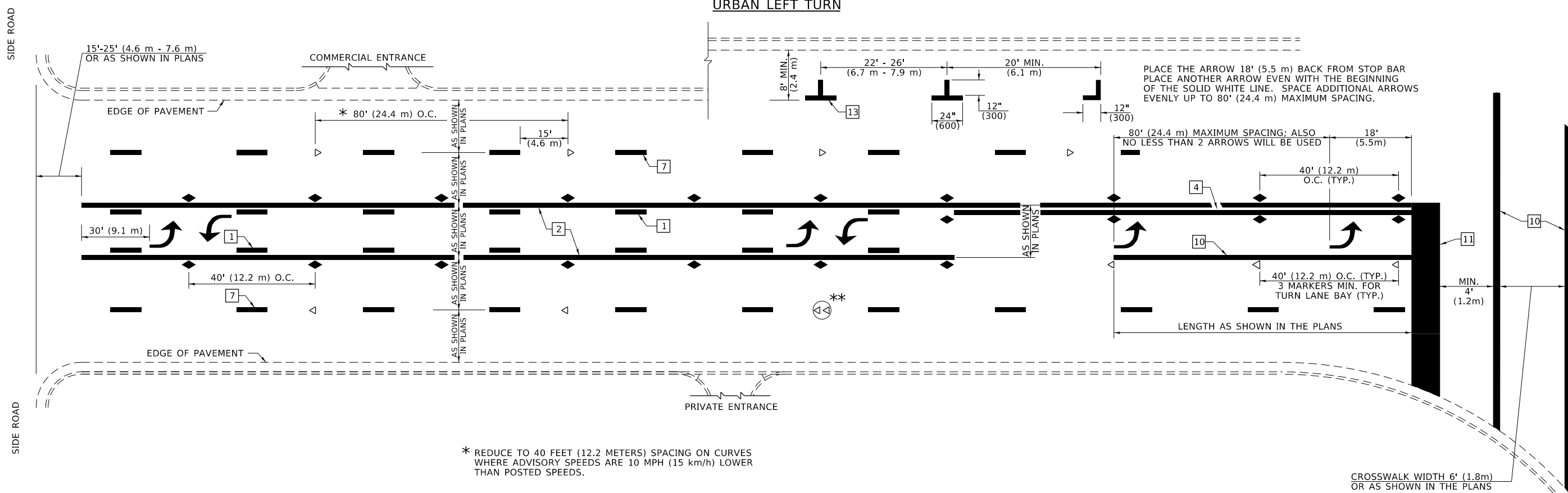

- * REDUCE TO 40 FEET (12.2 METERS) SPACING ON CURVES WHERE ADVISORY SPEEDS ARE 10 MPH (15 km/h) LOWER THAN POSTED SPEEDS.
- ** DOUBLE LANE LINE MARKERS SHALL BE SPECIFIED AND SPACED AS SHOWN IN HIGHWAY STANDARD 781001 FOR MULTI-LANE DIVIDED AND UNDIVIDED HIGHWAYS.

PAVEMENT MARKING LEGEND

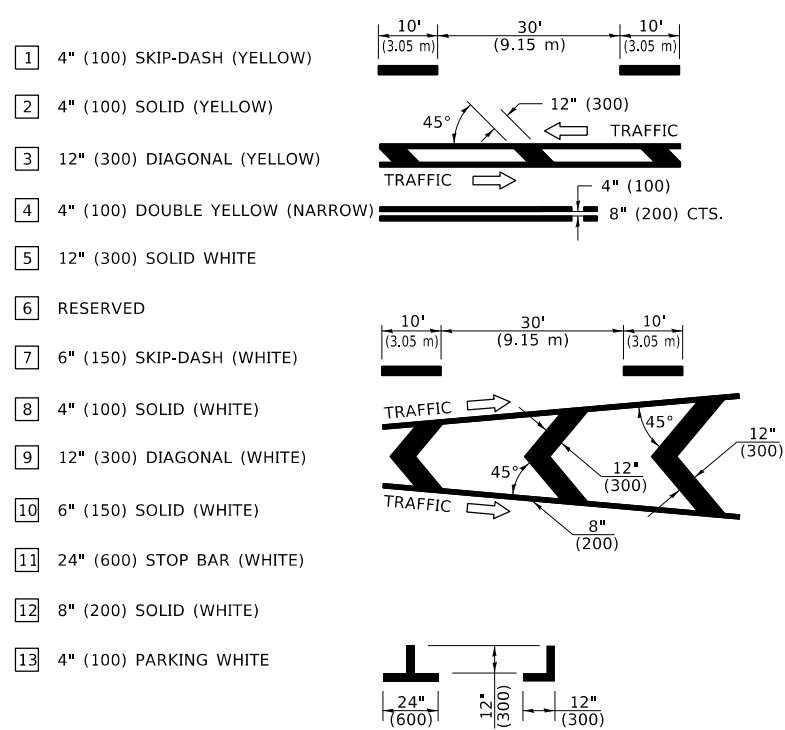

GENERAL NOTES

1. TURN ARROW PAIRS SHALL BE PLACED AT 250'(75 m) INTERVALS AND SHALL BE EVENLY SPACED BETWEEN BOTH ENDS OF THE BIDIRECTIONAL LEFT TURN LANE. USE A MINIMUM OF TWO PAIRS PER BLOCK.
2. THE SOLID YELLOW PAVEMENT MARKINGS [2] SHOULD GENERALLY START OR END NEAR THE RADIUS POINT OF EACH STREET RETURN EXCEPT WHERE ONE OR BOTH ENDS WOULD INCLUDE STOP BARS.
3. THE SKIP-DASH PAVEMENT MARKINGS [1] OR [7] SHOULD BE CENTERED BETWEEN BOTH ENDS OF EACH CITY BLOCK AND SHALL BE PLACED SO THEY LINE UP ACROSS FROM EACH OTHER.
4. USE LARGE ARROW SIZE FOR BOTH RURAL AND URBAN LOCATIONS. (SEE LAST PAGE OF SECTION 780x FOR SYMBOLS TABLE)
5. LANE LINE EXTENSIONS SHALL BE THE SAME COLOR AND WIDTH AS THE LANE LINE BEING EXTENDED.

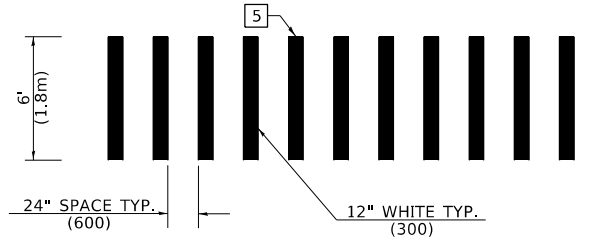

CROSSWALK DETAIL (DECATUR CITY LIMITS ONLY)

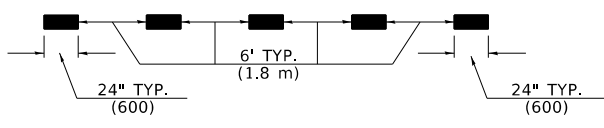

LANE LINE EXTENSIONS

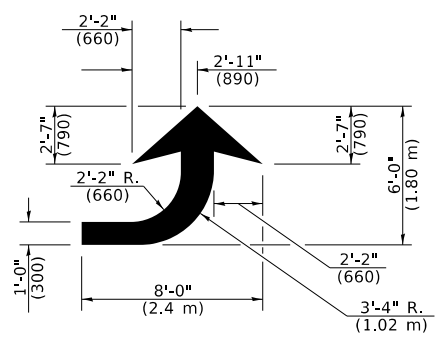

LEFT ARROW

REVERSE FOR RIGHT ARROW
AREA = 15.6 SQ. FT. (1.47 m²)
(WHITE)

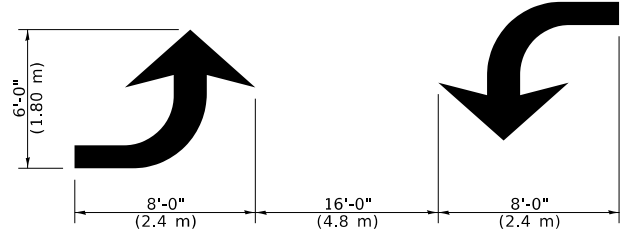

TYPICAL DOUBLE TURN ARROWS (WHITE)

NOT TO SCALE

Note: All dimensions are in INCHES (millimeters) unless otherwise shown.

DISTRICT 7 DETAIL NO. 7800001

MODEL: Default
FILE: \\hpc\p\pub\baronm.dwg
PROJECT: 74945-CADD\DATA\CADD\PROJECTS\74945-510-drawings.dwg

USER NAME = steffemk	DESIGNED -	REVISED -
PLOT SCALE = 100.0000' / in.	DRAWN -	REVISED -
PLOT DATE = 12/17/2020	CHECKED -	REVISED -
	DATE -	REVISED -

STATE OF ILLINOIS
DEPARTMENT OF TRANSPORTATION

PAVEMENT MARKING AND RAISED REFLECTIVE PAVEMENT MARKERS
(RURAL AND URBAN APPLICATIONS)

SCALE: SHEET 2 OF 4 SHEETS STA. TO STA.

F.A.P. RTE.	SECTION	COUNTY	TOTAL SHEETS	SHEET NO.
832	(113,114)RS-4	CLARK	46	43
CONTRACT NO. 74945				
ILLINOIS FED. AID PROJECT				

ISLAND

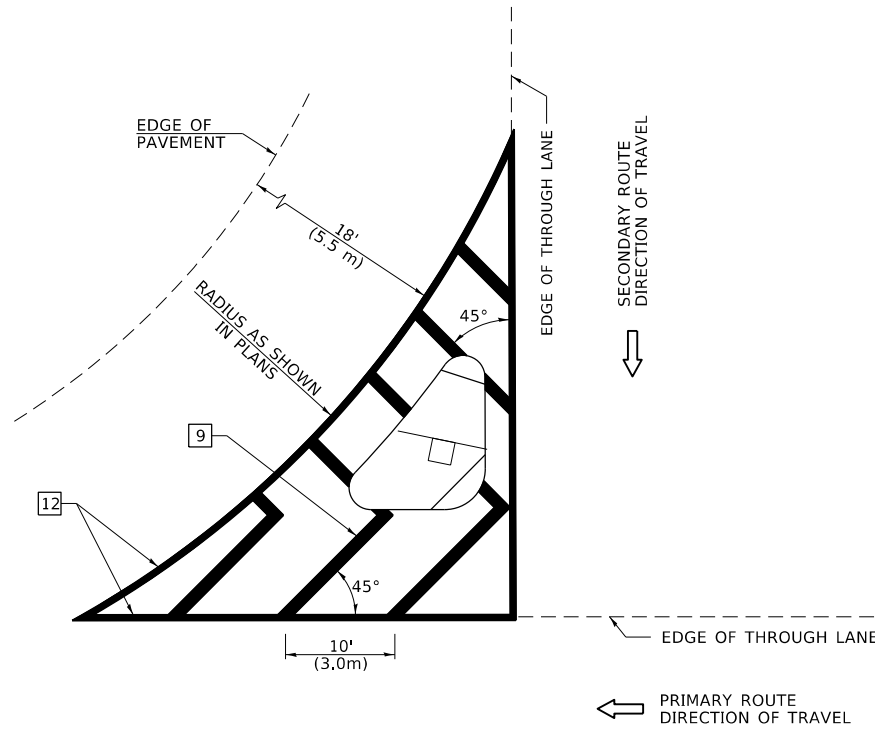

GENERAL NOTES

1. RAISED AND CORRUGATED MEDIANS SHALL BE OUTLINED WITH [2] IF PRESENT.
2. SOME OF THE INFORMATION INCLUDED WITH THIS DETAIL MAY NOT BE APPLICABLE TO THIS IMPROVEMENT.
3. PAVEMENT MARKINGS ARE TO BE EXTENDED THROUGH OMISSIONS WHEN APPLICABLE.
4. FINAL PAVEMENT MARKINGS SHALL BE IN PLACE PRIOR TO PLACING ANY RAISED REFLECTIVE PAVEMENT MARKERS.
5. THE FOLLOWING CRITERIA SHALL BE USED FOR SELECTING THE DIAGONAL PAVEMENT MARKING SPACING:

<30 MPH (<50 km/h)	15' (4.5 m)
30-45 MPH (50-75 km/h)	20' (6.0 m)
>45 MPH (>75 km/h)	30' (9.0 m)

PAVEMENT MARKING LEGEND

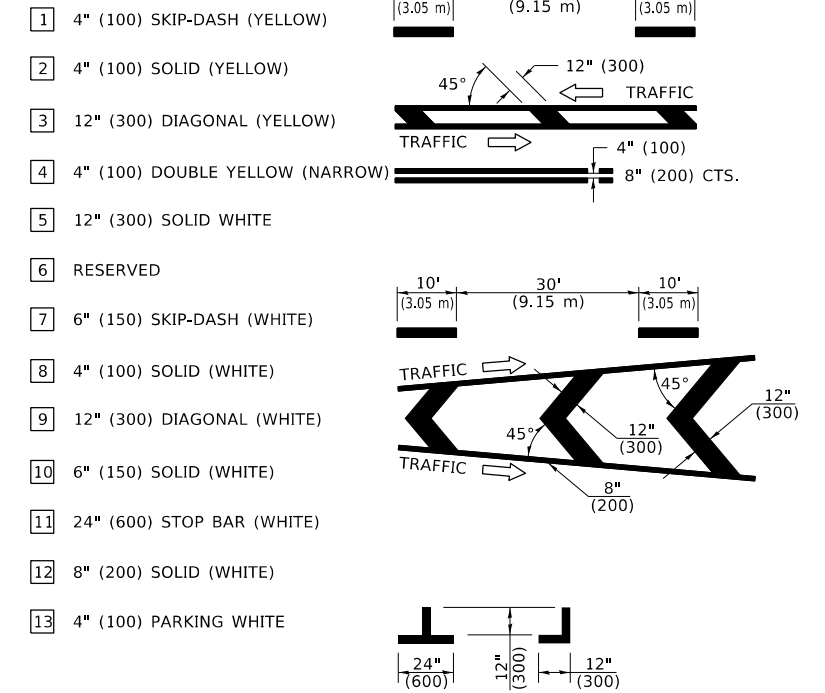

RURAL LEFT TURN STRIPING

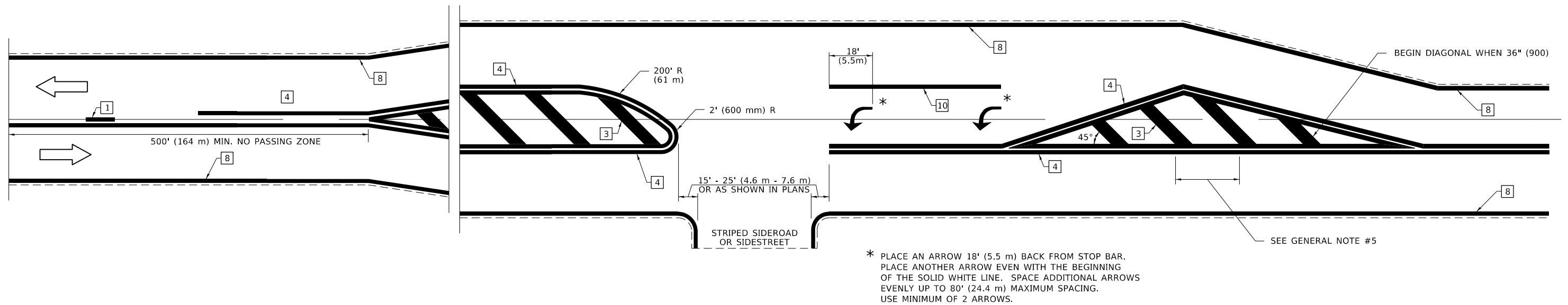

NOT TO SCALE

Note: All dimensions are in INCHES (millimeters) unless otherwise shown.

DISTRICT 7 DETAIL NO. 7800001

STATE OF ILLINOIS
DEPARTMENT OF TRANSPORTATION

PAVEMENT MARKING AND RAISED REFLECTIVE PAVEMENT MARKERS
(RURAL AND URBAN APPLICATIONS)

F.A.P. RTE.	SECTION	COUNTY	TOTAL SHEETS	SHEET NO.
832	(113,114)RS-4	CLARK	46	44
CONTRACT NO. 74945				

SCALE: SHEET 3 OF 4 SHEETS STA. TO STA.

ILLINOIS FED. AID PROJECT

MODEL: Default
FILE: h:\m\c\p\pub\baronm.d\at\illinois.gov\PIWDOT\Documents\DOT_Offices\Dist7\Project\74945\CADD\baronm.d\74945-sht-detail.dgn

USER NAME = steffemk	DESIGNED -	REVISED -
PLOT SCALE = 100,0000' / in.	DRAWN -	REVISED -
PLOT DATE = 12/17/2020	CHECKED -	REVISED -
	DATE -	REVISED -

PAVEMENT MARKINGS AT RAILROAD-HIGHWAY GRADE CROSSING

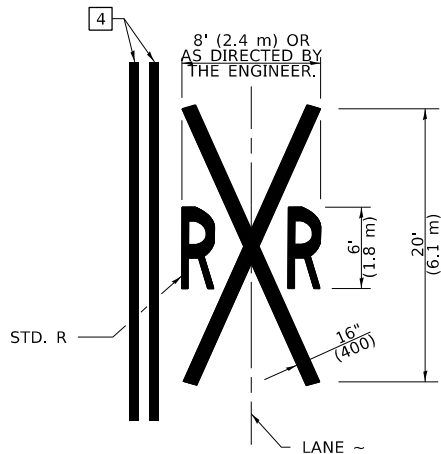
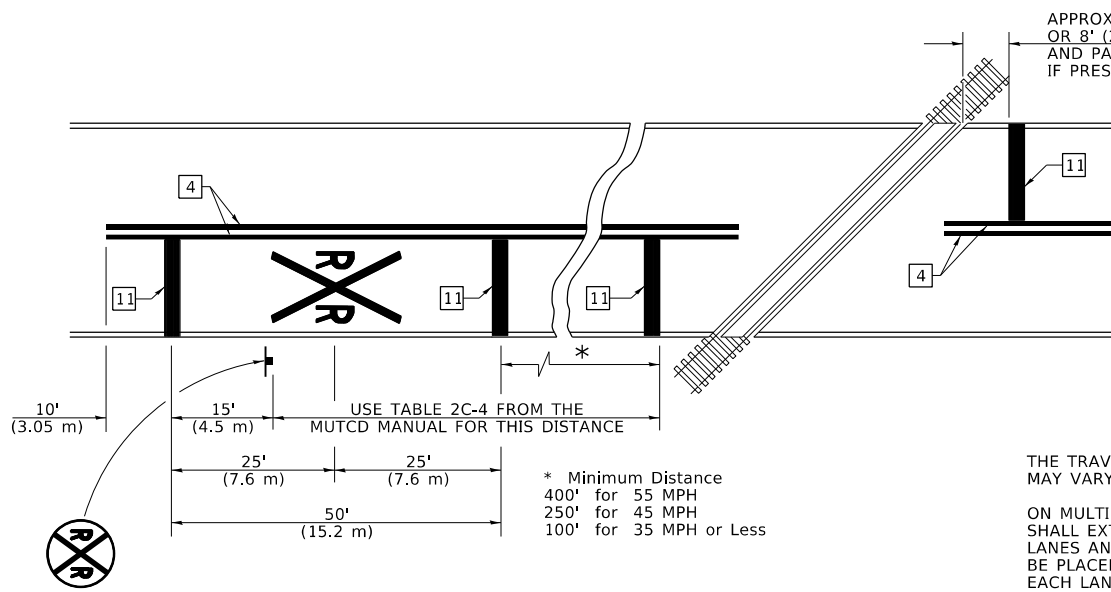

NOTES

THE TRAVERSE SPREAD OF THE "X" MAY VARY ACCORDING TO LANE WIDTH.

ON MULTI-LANE ROADS, THE STOP LINES SHALL EXTEND ACROSS ALL APPROACH LANES AND SEPARATE RXR SYMBOLS SHALL BE PLACED ADJACENT TO EACH OTHER IN EACH LANE.

WHEN THE PAVEMENT MARKING SYMBOL IS USED, A PORTION OF THE SYMBOL SHOULD BE LOCATED DIRECTLY ADJACENT TO THE ADVANCE WARNING SIGN (W10-1) AS PLACED BY TABLE II-1, CONDITION B OF THE MUTCD.

PAVEMENT MARKING LEGEND

- 1 4" (100) SKIP-DASH (YELLOW)
 - 2 4" (100) SOLID (YELLOW)
 - 3 12" (300) DIAGONAL (YELLOW)
 - 4 4" (100) DOUBLE YELLOW (NARROW)
 - 5 12" (300) SOLID WHITE
 - 6 RESERVED
 - 7 6" (150) SKIP-DASH (WHITE)
 - 8 4" (100) SOLID (WHITE)
 - 9 12" (300) DIAGONAL (WHITE)
 - 10 6" (150) SOLID (WHITE)
 - 11 24" (600) STOP BAR (WHITE)
 - 12 8" (200) SOLID (WHITE)
 - 13 4" (100) PARKING WHITE
-

RAILROAD CROSSING WITH INTERCONNECT ONLY

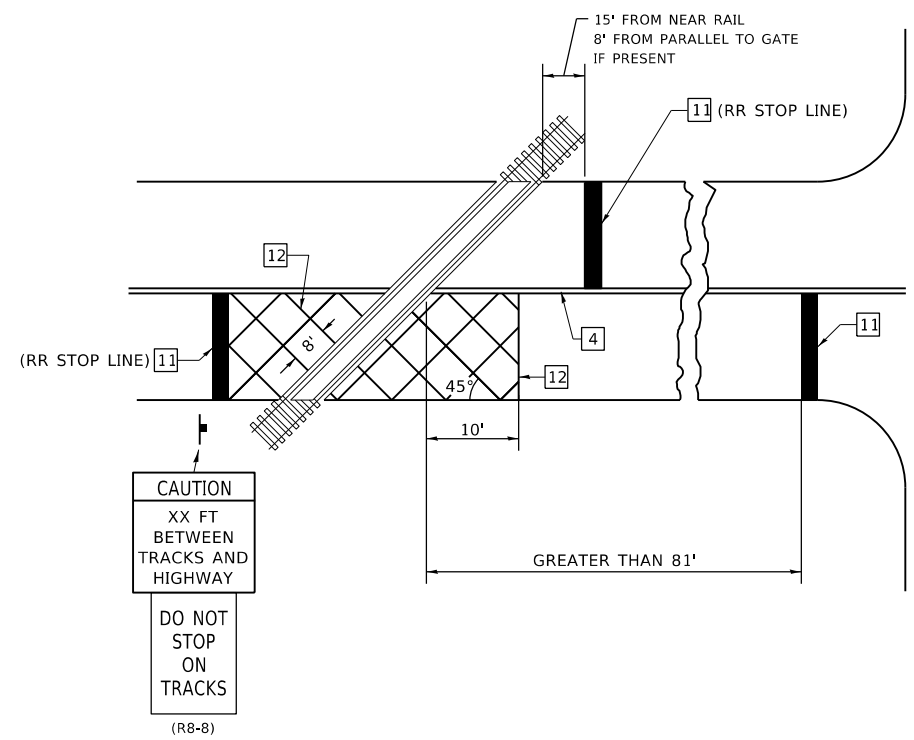

RAILROAD CROSSING WITH INTERCONNECT AND PRE-SIGNALS

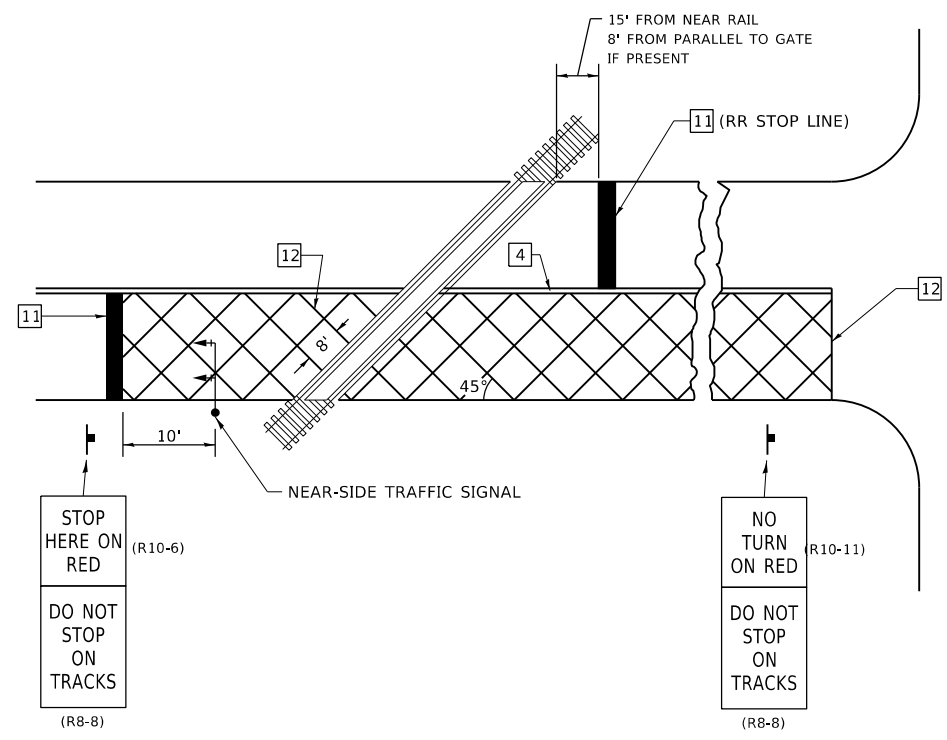

GENERAL NOTES

1. SUPPLEMENTAL PAVEMENT MARKINGS TO BE INSTALLED ONLY ON APPROACHES TO INTERSECTIONS CONTROLLED BY TRAFFIC SIGNALS WHICH ARE INTERCONNECTED WITH THE RAILROAD WARNING SIGNALS.
2. EXTEND PAVEMENT MARKINGS TO THE INTERSECTION ONLY WHERE NEAR-SIDE TRAFFIC SIGNALS ARE USED.

SUPPLEMENTAL PAVEMENT MARKING TREATMENT FOR RAILROAD-HIGHWAY GRADE CROSSING

NOT TO SCALE

Note: All dimensions are in INCHES (millimeters) unless otherwise shown.

DISTRICT 7 DETAIL NO. 7800001

MODEL: Default
FILE: \\nrcs-pub\baroncom.dta\illinois.gov\PWIDOT\Documents\DOT_Offices\Dist7\794945-std\detail.dgn

USER NAME = steffemk	DESIGNED -	REVISED -
PLOT SCALE = 100,0000' / in.	DRAWN -	REVISED -
PLOT DATE = 12/17/2020	CHECKED -	REVISED -
	DATE -	REVISED -

STATE OF ILLINOIS
DEPARTMENT OF TRANSPORTATION

PAVEMENT MARKING AND RAISED REFLECTIVE PAVEMENT MARKERS
(RURAL AND URBAN APPLICATIONS)

SCALE: SHEET 4 OF 4 SHEETS STA. TO STA.

F.A.P. RTE.	SECTION	COUNTY	TOTAL SHEETS	SHEET NO.
832	(113,114)RS-4	CLARK	46	45
CONTRACT NO. 74945				
ILLINOIS FED. AID PROJECT				

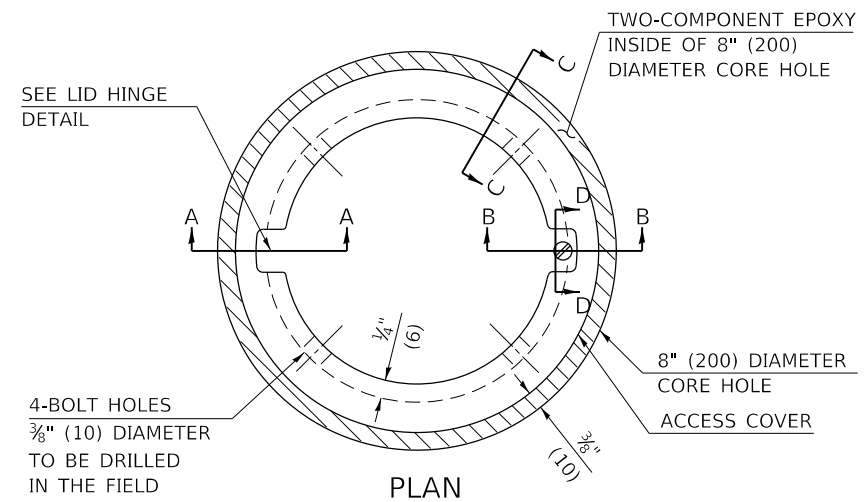

LEGEND

- ALUMINUM CASTING

- 5" (125) OR 6" (150) P.V.C. PIPE

- TWO-COMPONENT EPOXY

T = THICKNESS OF PAVEMENT STRUCTURE

H = THE THICKNESS OF THE SUB-BASE GRANULAR + 1" (25)

BILL OF MATERIAL

ALUMINUM CASTING OF THE DIMENSIONS AND SPECIFICATIONS SHOWN OR OTHER SUBJECT TO ENGINEER'S APPROVAL OF SHOP DRAWINGS, 4 EACH - $\frac{3}{16}$ " X 2" (M8 X 50) BOLTS WITH NUTS, EPOXY, 5" OR 6" (125 mm OR 150 mm) DIAMETER P.V.C. PIPE, SCHEDULE 40 (WHEN REQUIRED).

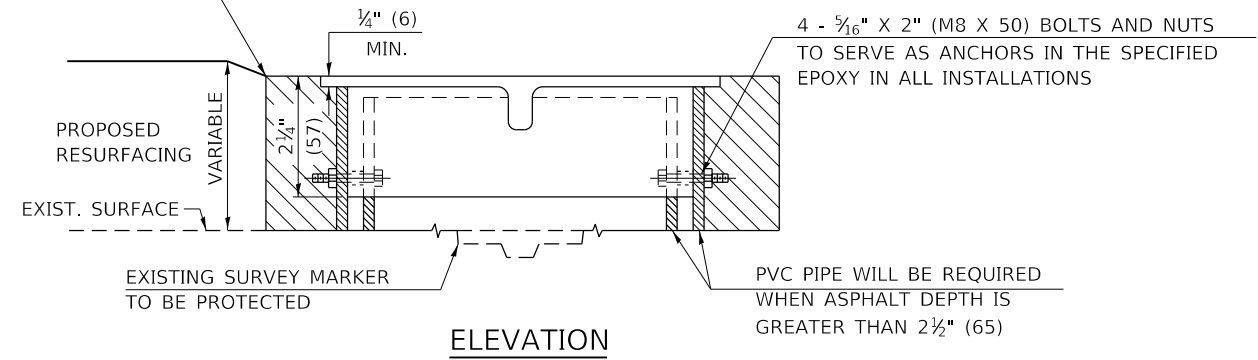
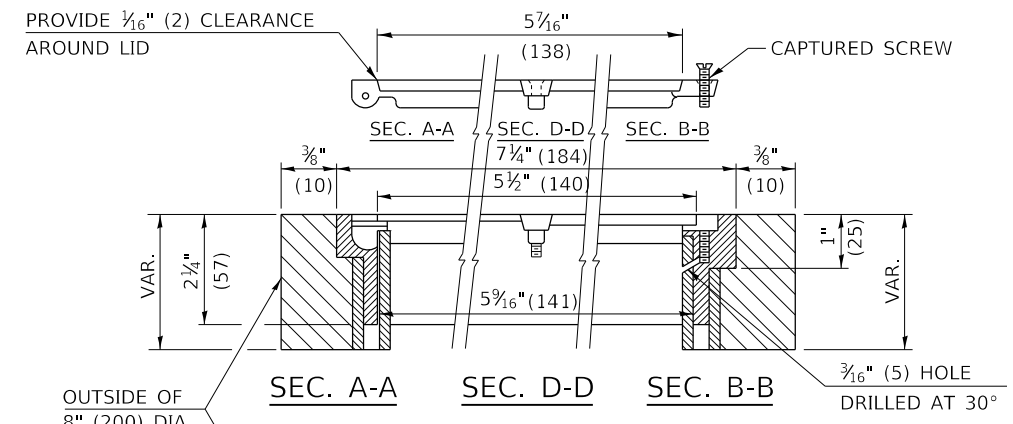
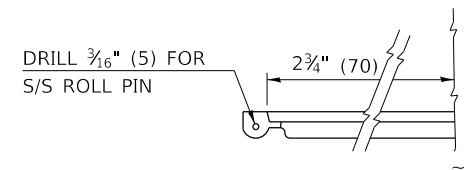
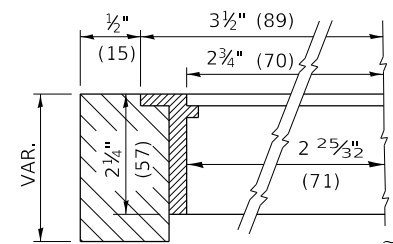

EXISTING SURVEY MARKER

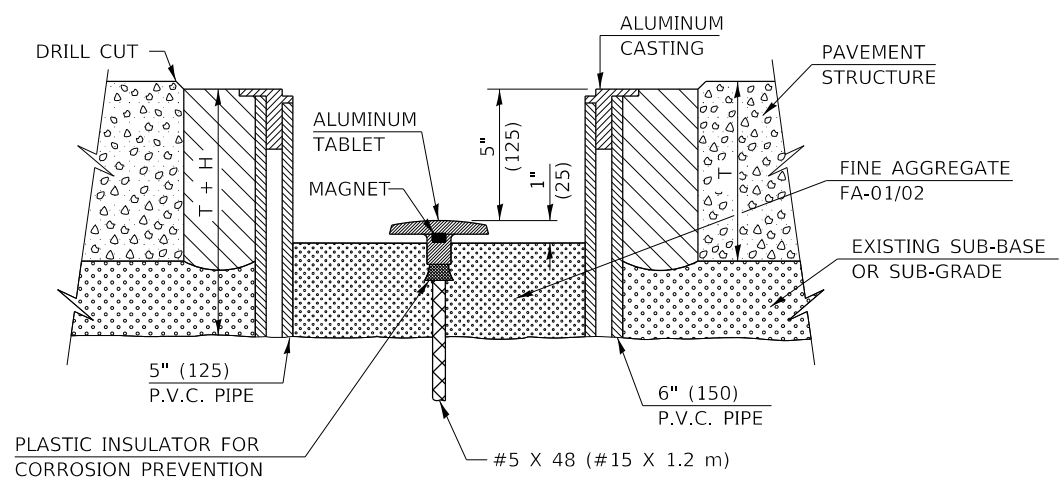

PROPOSED SURVEY MARKER

NOT TO SCALE

Note: All dimensions are in INCHES (millimeters) unless otherwise shown.

FILE NAME =	USER NAME = steffenk	DESIGNED -	REVISED - MAD 6-11
pw:\planroom.dot.illinois.gov\PIDOT\Documents\IDOT Offices\District 7\Projects\74945\DRAWN\CADsheets\0774945-shr-details.dgn		CHECKED -	REVISED -
		PLOT SCALE = 100.0000' / in.	REVISOR -
		PLOT DATE = 12/17/2020	DATE -

STATE OF ILLINOIS
DEPARTMENT OF TRANSPORTATION

SURVEY MARKER VAULT

SCALE: SHEET NO. 1 OF 1 SHEETS STA. TO STA.

DISTRICT 7 DETAIL NO. Z0070202

F.A.P. RTE.	SECTION	COUNTY	TOTAL SHEETS	SHEET NO.
832	(113,114)RS-4	CLARK	46	46
			CONTRACT NO. 74945	
ILLINOIS FED. AID PROJECT				