

**SUGGESTED STAGING AND MAINTENANCE OF TRAFFIC - I-55 OVER IL. RTE. 53**

**CONSTRUCTION STAGING - I-55 OVER IL. RTE. 53**

**PRE-STAGE (NOT ILLUSTRATED)**

- REMOVE THE OUTSIDE SHOULDER RUMBLE STRIPS WITHIN THE LIMITS OF THE TRAFFIC WEAVES THAT WILL SHIFT TRAFFIC ONTO THE SHOULDER. SEE DETAIL ON THIS SHEET.

(ALONG IL. RTE. 53)

- INSTALL PROTECTIVE SHIELDING ABOVE NORTHBOUND AND SOUTHBOUND LANES OF IL. RTE. 53.

**STAGE I**

- PERFORM THE BRIDGE DECK PATCHING ON THE INSIDE SHOULDER, LANE 1 & A PORTION OF LANE 2 FOR NORTHBOUND AND SOUTHBOUND LANES.

- REMOVE THE INSIDE SHOULDER RUMBLE STRIPS WITHIN THE LIMITS OF THE TRAFFIC WEAVES THAT WILL SHIFT TRAFFIC ONTO THE SHOULDER.

**STAGE II**

- PERFORM THE BRIDGE DECK PATCHING ON THE OUTSIDE SHOULDER, LANE 3 AND THE REMAINDER OF LANE 2 FOR NORTHBOUND AND SOUTHBOUND LANES.

- REPLACE ALL PAVEMENT MARKINGS AND REMOVED RPM REFLECTOR'S; REPLACE BRIDGE RPM REMOVED DURING PATCHING DECK AND INSTALL SHOULDER RUMBLE STRIPS.

(ALONG IL. RTE. 53)

- REMOVE PROTECTIVE SHIELDING.

**MAINTENANCE OF TRAFFIC - I-55 OVER IL. RTE. 53**

**PRE-STAGE**

- USE STANDARD 701401 FOR OUTSIDE SHOULDER RUMBLE STRIP REMOVAL WORK.

(ALONG IL. RTE. 53)

- USE DAILY NIGHTTIME LANE CLOSURES DURING THE HOURS OF 9:00 P.M. TO 5:00 A.M.

USE STANDARD 701601, URBAN LANE CLOSURE, MULTILANE, 1W OR 2W WITH NONTRAVERSABLE MEDIAN.

**STAGE I (NORTHBOUND AND SOUTHBOUND)**

- CLOSE INSIDE SHOULDER, LANE 1 AND A PORTION OF LANE 2 AS SHOWN ON THE PLANS AND USING STANDARD 701401 LANE CLOSURE, FREEWAYS/EXPRESSWAYS AND THE DETAIL FOR MULTI-LANE WEAVE.

- MAINTAIN TWO (2) TRAFFIC LANES UTILIZING A PORTION OF LANE 2, LANE 3 AND THE OUTSIDE SHOULDER. SEE SUGGESTED TRAFFIC CONTROL PLAN FOR WORK ZONE AND LANE CLOSURES.

**STAGE II (NORTHBOUND AND SOUTHBOUND)**

- CLOSE OUTSIDE SHOULDER, LANE 3 AND A PORTION OF LANE 2 AS SHOWN ON THE PLANS AND USING STANDARD 701401 LANE CLOSURE, FREEWAYS/EXPRESSWAYS AND THE DETAIL FOR MULTI-LANE WEAVE.

- MAINTAIN TWO (2) TRAFFIC LANES UTILIZING A PORTION OF LANE 2, LANE 1 AND THE INSIDE SHOULDER. SEE SUGGESTED TRAFFIC CONTROL PLAN FOR WORK ZONE AND LANE CLOSURES.

(ALONG IL. RTE. 53)

- USE DAILY NIGHTTIME LANE CLOSURES DURING THE HOURS OF 9:00 P.M. TO 5:00 A.M.

USE STANDARD 701601, URBAN LANE CLOSURE, MULTILANE, 1W OR 2W WITH NON-TRAVERSABLE MEDIAN.

**TRAFFIC CONTROL GENERAL NOTES**

1. ALL CONFLICTING PAVEMENT MARKINGS AND RAISED REFLECTIVE PAVEMENT MARKER REFLECTORS IN LANE DROPS AND TRAFFIC WEAVES SHALL BE REMOVED. THE COST OF THE REMOVAL OF THE REFLECTORS IN THE RAISED PAVEMENT MARKERS SHALL BE INCLUDED IN THE COST OF REPLACEMENT REFLECTOR.
2. THE TYPE AND SPACING OF THE BARRICADES SHALL BE AS SHOWN ON STANDARD 701401 AND THE DETAIL FOR FREEWAY SINGLE AND MULTI-LANE WEAVE.
3. ALL TEMPORARY PAVEMENT MARKINGS SHALL BE WET REFLECTIVE TAPE, TYPE III.
4. THE ALLOWED TIMES FOR 1-LANE AND 2-LANE CLOSURES ON I-55 ARE NOTED IN THE SPECIAL PROVISION "KEEPING EXPRESSWAYS OPEN TO TRAFFIC."

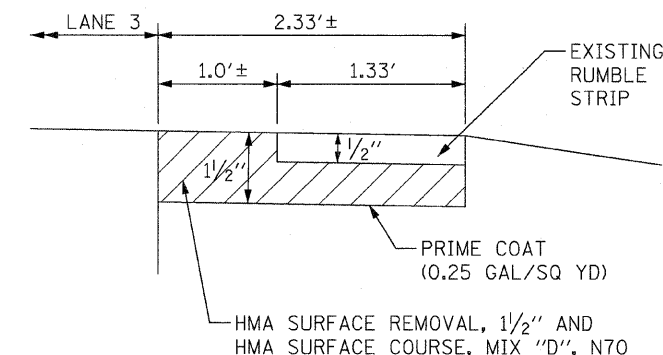

**RUMBLE STRIP REMOVAL DETAIL**

**SUGGESTED STAGING AND MAINTENANCE OF TRAFFIC - I-55 OVER JOLIET ROAD**

**CONSTRUCTION STAGING - I-55 OVER JOLIET ROAD**

**PRE-STAGE (NOT ILLUSTRATED)**

- REMOVE THE OUTSIDE SHOULDER RUMBLE STRIPS WITHIN THE LIMITS OF THE TRAFFIC WEAVES THAT WILL SHIFT TRAFFIC ONTO THE SHOULDER. SEE DETAIL ON THIS SHEET.

(JOLIET ROAD)

- INSTALL PROTECTIVE SHIELDING ABOVE SOUTHBOUND JOLIET ROAD.

**STAGE I (NORTHBOUND AND SOUTHBOUND)**

- PERFORM THE BRIDGE DECK PATCHING ON THE INSIDE SHOULDER, LANE 1 AND A PORTION OF LANE 2 FOR NORTHBOUND AND SOUTHBOUND.

- REMOVE THE INSIDE SHOULDER RUMBLE STRIPS WITHIN THE LIMITS OF THE TRAFFIC WEAVES THAT WILL SHIFT TRAFFIC ONTO THE SHOULDER.

**STAGE II (NORTHBOUND AND SOUTHBOUND)**

- PERFORM THE BRIDGE DECK PATCHING ON THE OUTSIDE SHOULDER, LANE 3 AND THE REMAINDER OF LANE 2 NORTHBOUND.

- PERFORM THE BRIDGE DECK PATCHING ON THE SOUTHBOUND ENTRANCE RAMP, LANE 3 AND THE REMAINDER OF LANE 2 SOUTHBOUND.

- (NORTHBOUND) REPLACE ALL PAVEMENT MARKINGS AND REMOVED RPM REFLECTOR'S; REPLACE BRIDGE RPM REMOVED DURING PATCHING DECK AND INSTALL SHOULDER RUMBLE STRIPS.

**SUB-STAGE II (SOUTHBOUND ENTRANCE RAMP)**

- PERFORM THE BRIDGE DECK PATCHING ON THE OUTSIDE SHOULDER AND REMAINING ENTRANCE RAMP PAVEMENT.

- (SOUTHBOUND) REPLACE ALL PAVEMENT MARKINGS AND REMOVED RPM REFLECTOR'S; REPLACE BRIDGE RPM REMOVED DURING PATCHING DECK AND INSTALL SHOULDER RUMBLE STRIPS.

(JOLIET ROAD)

- REMOVE PROTECTIVE SHIELDING ABOVE SOUTHBOUND JOLIET ROAD.

**MAINTENANCE OF TRAFFIC - I-55 OVER JOLIET ROAD**

**PRE-STAGE**

- USE STANDARD 701401 FOR OUTSIDE SHOULDER RUMBLE STRIP REMOVAL WORK.

(ALONG JOLIET RD)

- USE DAILY DAYTIME LANE CLOSURES DURING THE HOURS OF 9:00 AM TO 3:00 PM. USE STANDARD 701421, LANE CLOSURE, MULTILANE, DAY OPERATIONS ONLY, FOR SPEEDS >= 45 MPH TO 55 MPH.

**STAGE I (NORTHBOUND AND SOUTHBOUND)**

- CLOSE INSIDE SHOULDER, LANE 1 AND A PORTION OF LANE 2 AS SHOWN ON THE PLANS AND USING STANDARD 701401 LANE CLOSURE, FREEWAYS/EXPRESSWAYS AND THE DETAIL FOR MULTI-LANE WEAVE.

- (NORTHBOUND) MAINTAIN TWO (2) TRAFFIC LANES UTILIZING A PORTION OF LANE 2, LANE 3 AND THE OUTSIDE SHOULDER. SEE SUGGESTED TRAFFIC CONTROL PLAN FOR WORK ZONE AND LANE CLOSURES.

- (SOUTHBOUND) MAINTAIN TWO (2) SOUTHBOUND TRAFFIC LANES UTILIZING A PORTION OF LANE 2, LANE 3 AND THE SOUTHBOUND ON-RAMP TAPER. REDUCE THE RAMP WIDTH TO 12 FEET, ALONG THE OUTSIDE EDGE OF THE RAMP, PRIOR TO THE BRIDGE ON SHOWN ON THE PLANS AND USING STANDARD 701411 LANE CLOSURE, MULTILANE, AT ENTRANCE AND EXIT RAMP, FOR SPEEDS >= 45 MPH, PRIOR TO THE WORK ZONE TO REDUCE THE RAMP WIDTH.

**STAGE II (NORTHBOUND AND SOUTHBOUND)**

- CLOSE OUTSIDE SHOULDER, LANE 3 AND A PORTION OF LANE 2 AS SHOWN ON THE PLANS AND USING STANDARD 701401 LANE CLOSURE, FREEWAYS/EXPRESSWAYS AND THE DETAIL FOR MULTI-LANE WEAVE.

- MAINTAIN TWO (2) TRAFFIC LANES UTILIZING INSIDE SHOULDER, LANE 1 AND PART OF LANE 2. SEE SUGGESTED STAGING PLAN FOR WORK ZONE AND LANE CLOSURE LAYOUT.

- MAINTAIN THE RAMP TRAFFIC CONTROL AS SHOWN ON STAGE I.

**SUB-STAGE II (SOUTHBOUND ENTRANCE RAMP)**

- COMPLETE SE HALF OF BRIDGE REPAIRS AND COMPLETE ALL PAVEMENT MARKING AT THE IL RTE 53 BRIDGE. REMOVE ALL TRAFFIC CONTROL TO STATION 1680+70 SOUTH OF THE JOLIET ROAD BRIDGE.

- MAINTAIN TWO (2) SOUTHBOUND I-55 TRAFFIC LANES AS SHOWN ON STAGE II TO STATION 1680+70.

- SHIFT RAMP TRAFFIC TO THE LEFT AS SHOWN ON THE PLANS.

(ALONG JOLIET RD)

- USE DAILY DAYTIME LANE CLOSURES DURING THE HOURS OF 9:00 AM TO 3:00 PM USE STANDARD 701421, LANE CLOSURE, MULTILANE, DAY OPERATIONS ONLY, FOR SPEEDS >= 45 MPH TO 55 MPH.

FILE NAME = D168E59_sht.stagenotes.dwg PLOT DATE = 12/31/2008	 <b>CHRISTIAN-ROGE &amp; ASSOCIATES, INC.</b> ENGINEERS-PLANNERS-SURVEYORS 211 WEST WACKER DRIVE CHICAGO, ILLINOIS 60606 PHONE: (312)372-2023 FAX: (312)372-5274	DESIGNED - S.J.P.	REVISED -	<b>STATE OF ILLINOIS</b> <b>DEPARTMENT OF TRANSPORTATION</b>	<b>SUGGESTED MAINTENANCE OF TRAFFIC NOTES</b> <b>I-55 OVER IL. RTE. 53 AND JOLIET ROAD</b>	F.A.I. RTE. 55	SECTION 2008-028 BR	COUNTY WILL	TOTAL SHEETS 29	SHEET NO. 4
		DRAWN - A.Y.	REVISED -			SCALE: NONE SHEET NO. 1 OF 6 SHEETS STA. TO STA.			FED. ROAD DIST. NO. 1 [ILLINOIS] FED. AID PROJECT	
		CHECKED - E.J.M.	REVISED -				CONTRACT NO. 60E59			
		DATE - DECEMBER 30, 2008	REVISED -							