

| F.A.P. RTE. | SECTION | COUNTY | TOTAL SHEETS | SHEET NO. |
|---------------------------|-----------------------|---------------------------|--------------|-----------|
| 681 | (115)RS-3 & (116)RS-2 | FORD & LIVINGSTON | 12 | 8 |
| STA. _____ | | TO STA. _____ | | |
| FED. ROAD DIST. NO. _____ | | ILLINOIS FED. AID PROJECT | | |

CONTRACT #66422

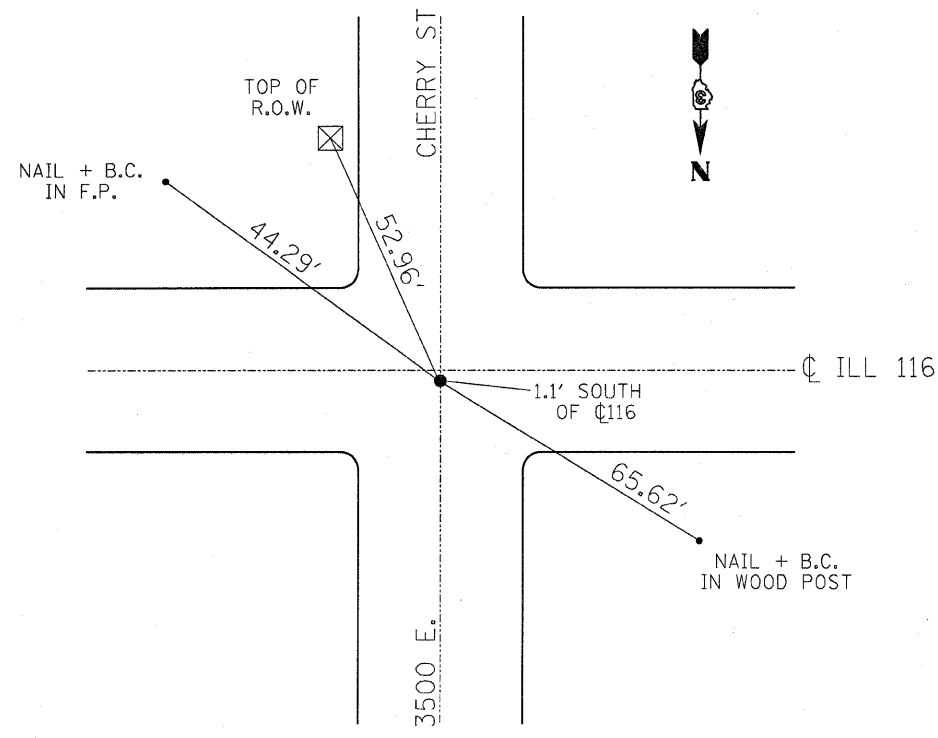

**BRASS PLUG
SEC 23 T28N-R 8E**

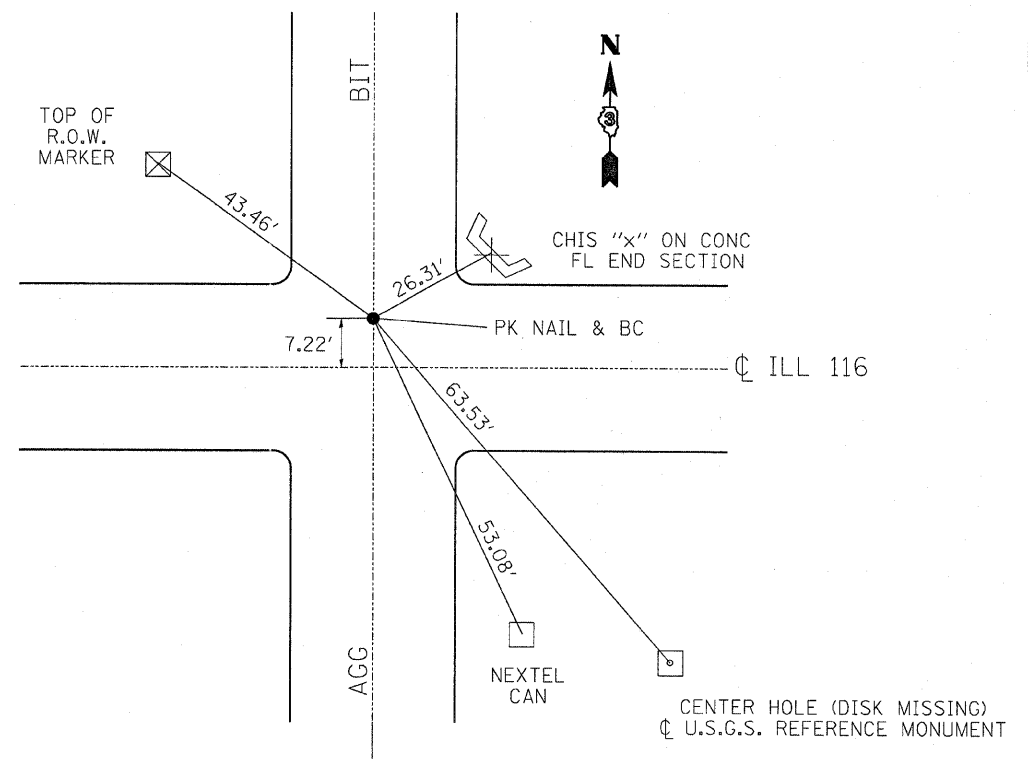

**BRASS PLUG
SEC 30 T28N-R 9E**

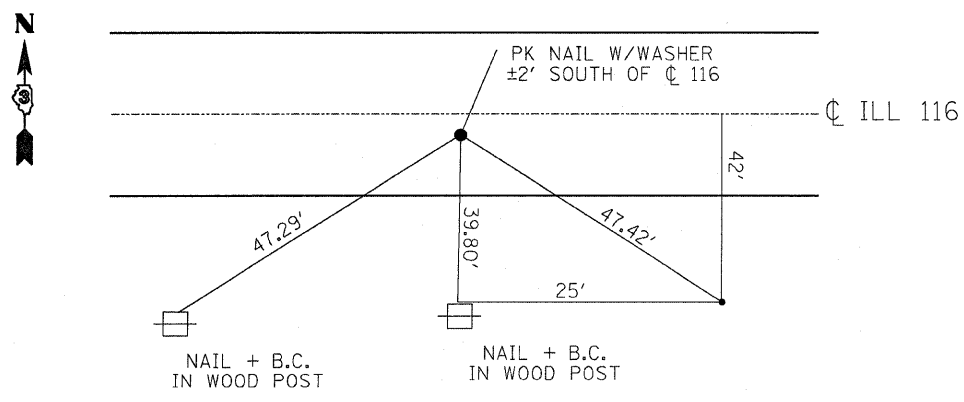

SEC 30 T28N-R 9E

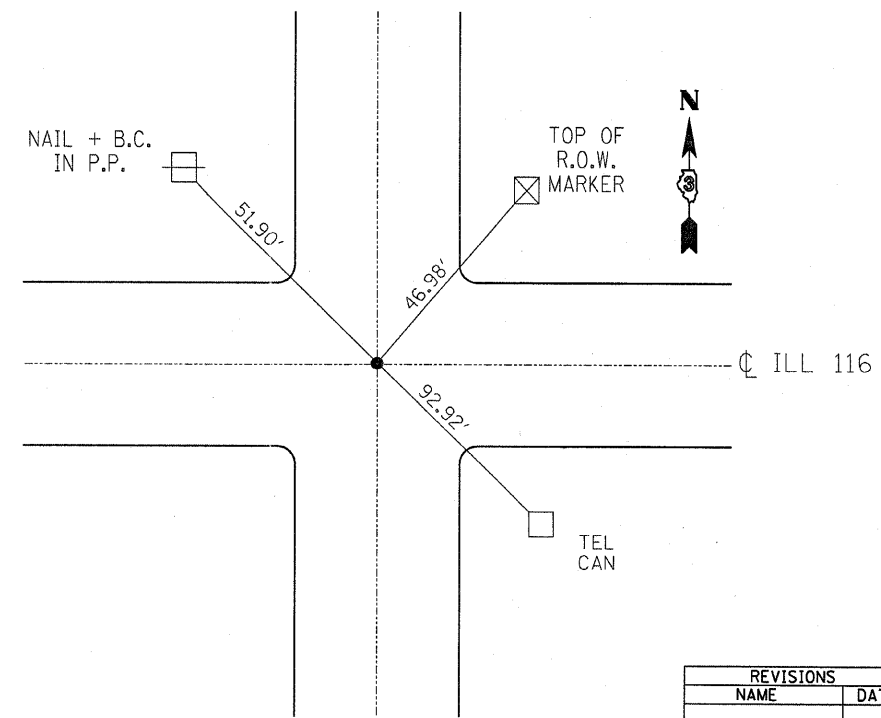

**BRASS PLUG
SEC 19 T28N-R 9E**

| REVISIONS | |
|-----------|------|
| NAME | DATE |
| | |
| | |
| | |
| | |
| | |
| | |
| | |
| | |
| | |
| | |

ILLINOIS DEPARTMENT OF TRANSPORTATION

TIE POINTS

SCALE: VERT. _____
HORIZ. _____

DATE _____ DRAWN BY _____
CHECKED BY _____

-DAT- 9:16:00 AM
 c:\pwwork\pwwork\car\pentferd\j\dms82640\dat\11s.dgn