

F.A. RTE.	SECTION	COUNTY	TOTAL SHEETS	SHEET NO.
*	*	LA SALLE	48	6
STA.		TO STA.		
FED. ROAD DIST. NO.		ILLINOIS	FED. AID PROJECT	
* FAP 68 & 68 ALT (IL 23 NB & SB)				
** (35, 51 & 48 CS, 12)TS				

ELECTRICAL LOAD FOR INTERSECTION				
STREET NAME	COMPONENT	NUMBER	WATTAGE EACH	BURNTIME %
LA SALLE STREET (IL 23 SB)	RED	4	10	42
	YELLOW	4	19	5
	GREEN	4	14	53
		4	7	100
		4	5	53
SUPERIOR STREET	RED	4	10	68
	YELLOW	4	19	5
	GREEN	4	14	27
		4	7	100
		4	5	27
TRAFFIC SIGNAL CABINET	CONTROLLER	1	6	100
	UPS	1	50	100
	EMERGENCY VEHICLE PREEMPT	3	--	--

AGENCY RESPONSIBLE FOR TRAFFIC SIGNAL ENERGY CHARGES:
CITY OF OTTAWA

NOTE:

DAMPENING DEVICE SHALL CONSIST OF A 24" X 30" TYPE 1, UNPAINTED ALUMINUM SIGN STOCK MOUNTED HORIZONTALLY ON TOP OF MAST ARM WITH THE 30" LENGTH PERPENDICULAR TO THE ARM. COST OF THE DAMPENING DEVICE IS INCLUDED IN THE MAST ARM PAY ITEM.

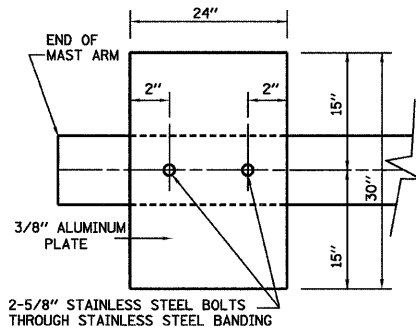

NOTE:
MOUNT DAMPENING PLATE TO END OF EACH TRAFFIC SIGNAL MAST ARM.

DAMPENING PLATE DETAIL - TOP VIEW

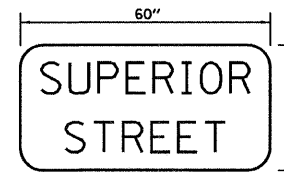

TYPE ZZ SHEETING REQUIRED
8" D SERIES LETTERS
1 SIGNS REQUIRED = 12.5 SQ. FT. EACH
= 12.5 SQ. FT. TOTAL

THIS STREET NAME SIGN SHALL BE PLACED ON THE MAST ARMS PARALLEL WITH SUPERIOR STREET

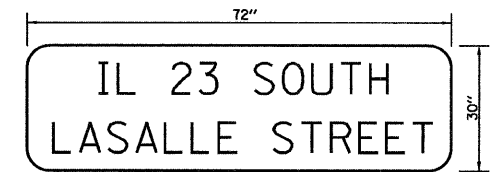

TYPE ZZ SHEETING REQUIRED
8" D SERIES LETTERS (STATE ROUTE LETTERING)
6" D SERIES LETTERS (CITY STREET LETTERING)
2 SIGNS REQUIRED = 15 SQ. FT. EACH
= 30 SQ. FT. TOTAL

THIS STREET NAME SIGN SHALL BE PLACED ON THE MAST ARMS PARALLEL WITH LA SALLE STREET

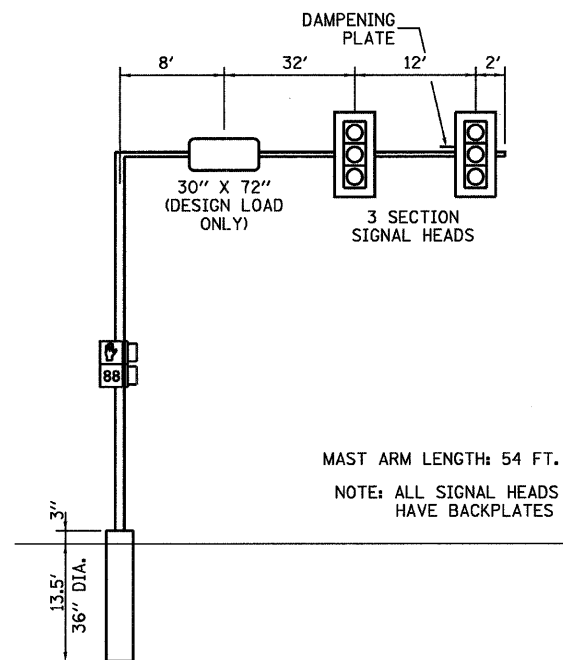

MAST ARM LENGTH: 54 FT.
NOTE: ALL SIGNAL HEADS HAVE BACKPLATES

EASTBOUND

NORTHEAST CORNER
NOT TO SCALE

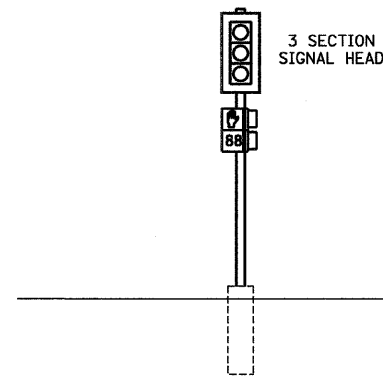

SOUTHBOUND

SOUTHEAST CORNER
NOT TO SCALE

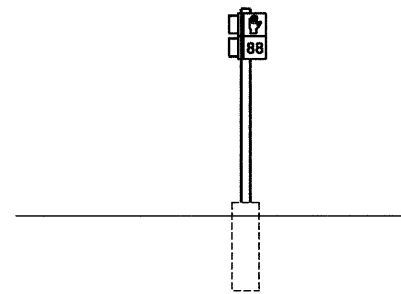

WESTBOUND

NORTHWEST CORNER
NOT TO SCALE

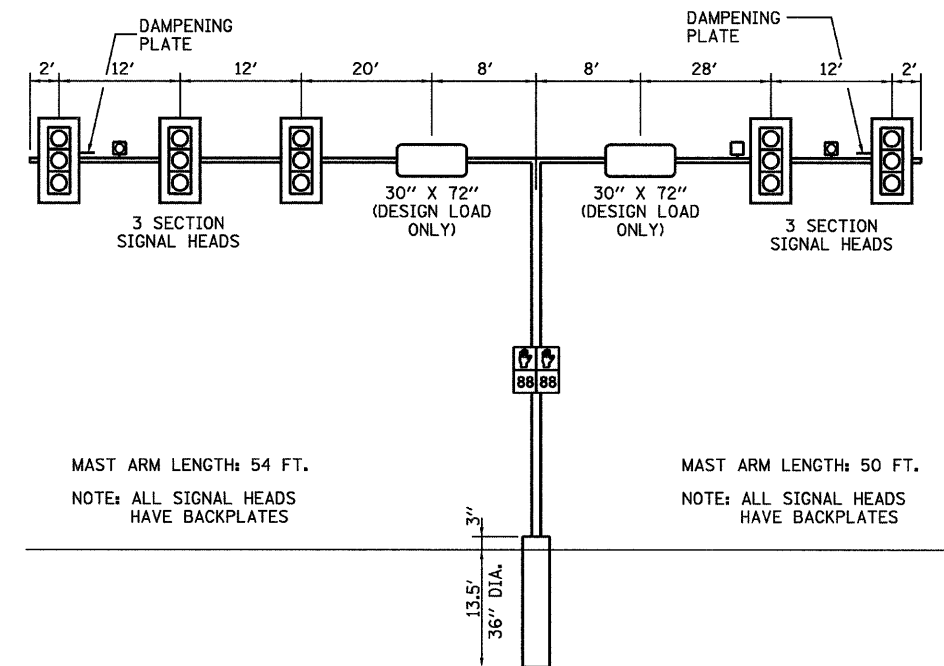

MAST ARM LENGTH: 54 FT.
NOTE: ALL SIGNAL HEADS HAVE BACKPLATES

SOUTHBOUND

SOUTHWEST CORNER
NOT TO SCALE

MAST ARM LENGTH: 50 FT.
NOTE: ALL SIGNAL HEADS HAVE BACKPLATES

WESTBOUND

LA SALLE STREET (IL 23 SB) / SUPERIOR STREET

MAST ARM AND POLE SHALL BE DESIGNED FOR THE WORST CASE LOADING CONDITION WHEREBY ALL THE SIGNAL HEADS ARE LOCATED 2 FEET FURTHER OUT THAN POSITION SHOWN. HOWEVER THE INTENT IS THAT ALL SIGNAL HEADS BE CENTERED ABOVE THE LANES.

REVISIONS	
NAME	DATE

ILLINOIS DEPARTMENT OF TRANSPORTATION
TRAFFIC SIGNAL DETAILS
FAP 68 ALT (IL 23 SB)/LA SALLE ST
AND SUPERIOR STREET
SECTION 35,51 & 48 CS, 12)TS
LA SALLE COUNTY

SCALE: VERT. DRAWN BY ARR
HORIZ. CHECKED BY JLS
DATE 11/08