

F.A.I. RTE.	SECTION	COUNTY	TOTAL SHEETS	SHEET NO.
74	D4 I-74 ITS SYSTEM-2	PEORIA, TAZEWELL	20	1
ILLINOIS			CONTRACT NO. 68273	

D-94-084-02      ★ 20+1=21

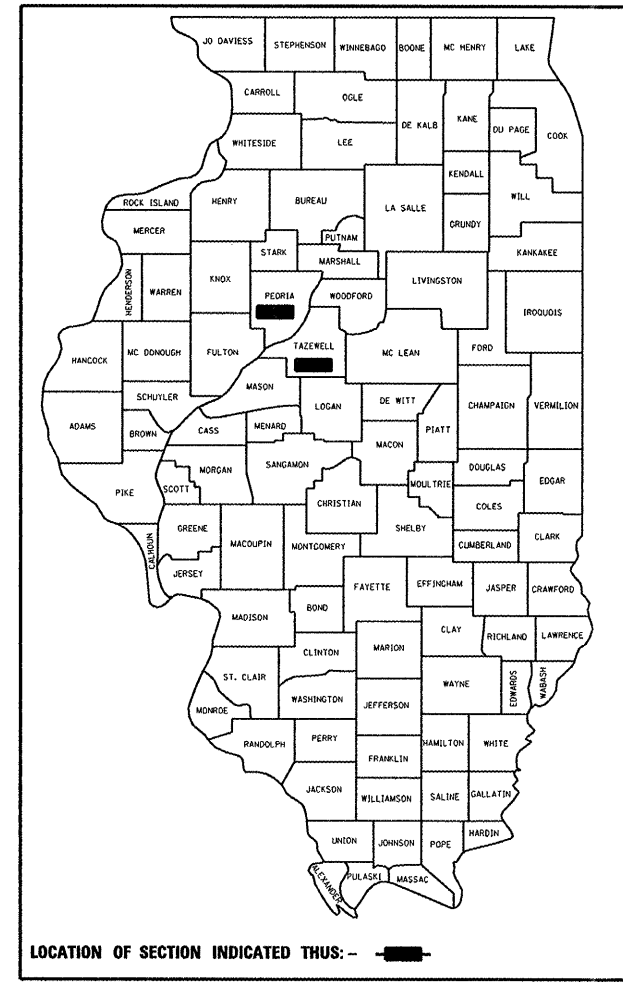

STATE OF ILLINOIS  
DEPARTMENT OF TRANSPORTATION  
DIVISION OF HIGHWAYS

SUBMITTED 11/6/2008

*[Signature]*  
DEPUTY DIRECTOR OF HIGHWAYS, REGION ENGINEER

December 5, 2008  
*[Signature]*  
ENGINEER OF DESIGN AND ENVIRONMENT

December 5, 2008  
*[Signature]*  
DIRECTOR OF HIGHWAYS, CHIEF ENGINEER

PRINTED BY THE AUTHORITY  
OF THE STATE OF ILLINOIS

FOR INDEX OF SHEETS, SEE SHEET NO. 2

STATE OF ILLINOIS  
DEPARTMENT OF TRANSPORTATION  
DIVISION OF HIGHWAYS

# PROPOSED HIGHWAY PLANS

FAI ROUTE 74  
SECTION D4 I-74 ITS SYSTEM-2  
PROJECT IM-HPP-074-3(062) 093  
PROJECT DESCRIPTION: ATMS SOFTWARE  
PEORIA-TAZEWELL COUNTIES  
C-94-101-02

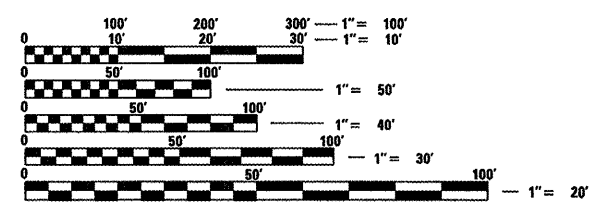

FULL SIZE PLANS HAVE BEEN PREPARED USING STANDARD ENGINEERING SCALES. REDUCED SIZED PLANS WILL NOT CONFORM TO STANDARD SCALES. IN MAKING MEASUREMENTS ON REDUCED PLANS, THE ABOVE SCALES MAY BE USED.

J.U.L.I.E.  
JOINT UTILITY LOCATION INFORMATION FOR EXCAVATION  
1-800-892-0123  
OR 811

PROJECT ENGINEER: ERIC HOWALD (309) 671-4481  
PROJECT MANAGER: RANDY LANINGA (309) 671-4477

CONTRACT NO. 68273  
CATALOG NO. 031087-39D

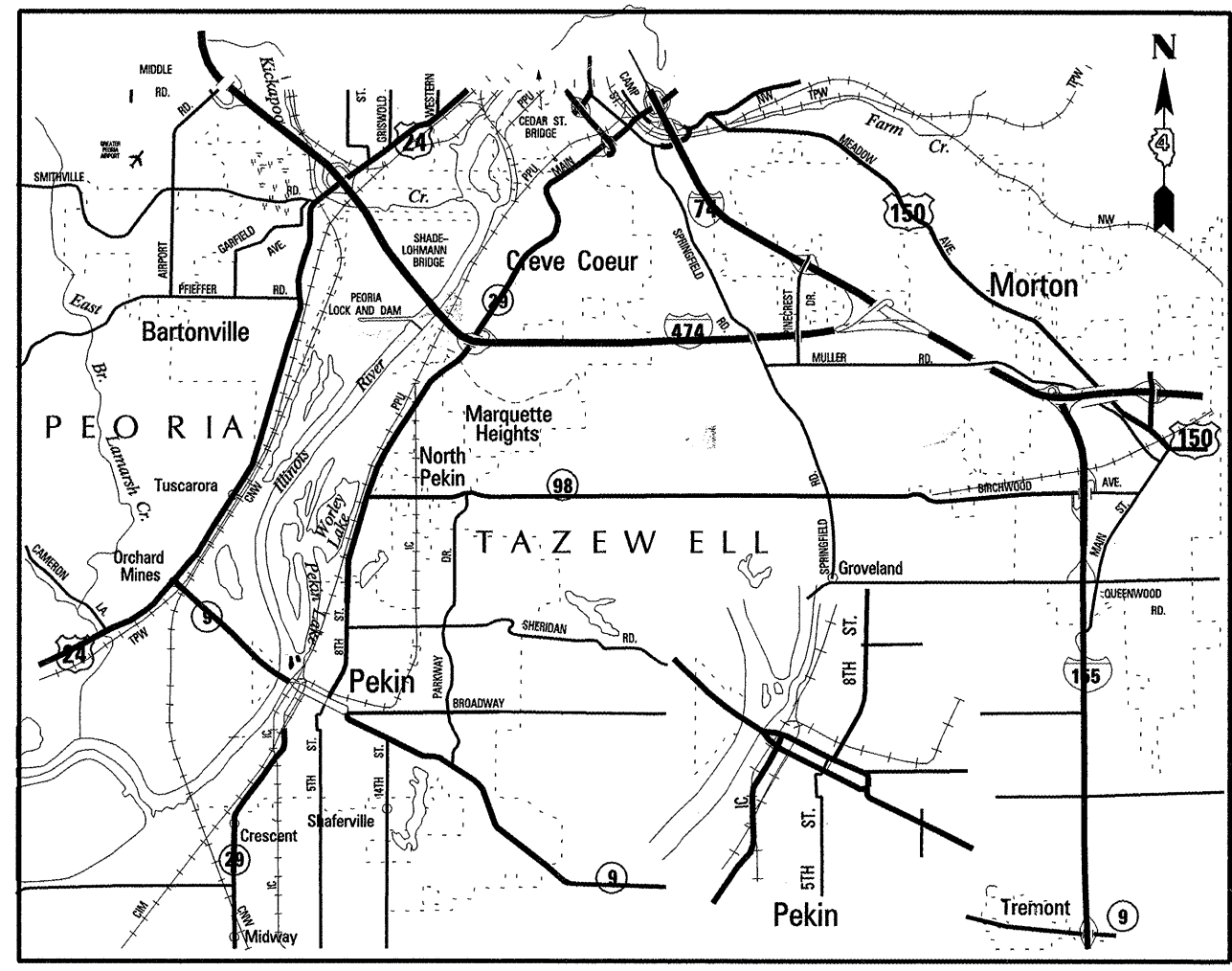

N40° 41.48

W89° 35.21

INDEX OF SHEETS	
SHEET NO.	DESCRIPTION
1	COVER SHEET
2	INDEX OF QUANTITIES
3	SUMMARY OF QUANTITIES
4	EXISTING VIDEO SELECTION AND DISPLAY SCHEMATIC - VIDEO WALL
5	EXISTING CAMERA CONTROL - CCTV CAMERA CONTROL MODEL
6	EXISTING TRAFFIC DATA COLLECTION SCHEMATIC - MICROWAVE DETECTOR STATIONS
7	EXISTING TRAFFIC DATA COLLECTION SCHEMATIC - INDUCTIVE LOOP DETECTOR STATIONS
8	EXISTING DYNAMIC MESSAGE SIGN (DMS)SCHEMATIC
9	EXISTING ETHERNET NETWORK SCHEMATIC
10	EXISTING DATA NETWORK SCHEMATIC - PEORIA DEPARTMENT OF PUBLIC WORKS (PPW)
11	EXISTING DATA NETWORK SCHEMATIC - PEORIA EMERGENCY COMMUNICATION CANETER (ECC)
12	EXISTING DATA NETWORK SCHEMATIC - EAST PEORIA PUBLIC SAFETY (EPPS)
13	EXISTING DATA NETWORK SCHEMATIC - EAST PEORIA PUBLIC WORKS (EPPW)
14	EXISTING DATA NETWORK SCHEMATIC - I-74 @ FONDULAC BRIDGE
15	EXISTING DATA NETWORK SCHEMATIC - I-74 @ I-474 EAST TOWER
16	EXISTING DATA NETWORK SCHEMATIC - IDOT COMMUNICATIONS CENTER
17	EXISTING CCTV EQUIPMENT SCHEMATIC
17A	VIDEO SUBSYSTEM NETWORK SCHEMATIC
18	EXISTING SYSTEM SCHEMATIC - HIGHWAY RAILROAD INFORMATION (HRI) EQUIPMENT
19	EXISTING ITS NETWORK SCHEMATIC
20	PROPOSED ITS NETWORK SCHEMATIC

SUMMARY OF QUANTITIES				PEORIA COUNTY		TAZEWELL COUNTY	
				CONST. TYPE CODE ITS Y035 10 % STATE 90% FED URBAN		CONST. TYPE CODE ITS Y035 10 % STATE 90% FED URBAN	
CODE NUMBER	ITEM DESCRIPTION	UNIT	TOTAL QTY.				
67100100	MOBILIZATION	L SUM	1.0	0.5		0.5	
X8620020	UNINTERRUPTIBLE POWER SUPPLY	EACH	2.0	1.0		1.0	
X8710050	FIBER OPTIC ETHERNET DROP AND REPEAT SWITCH	EACH	4.0	2.0		2.0	
X0326248	ATMS SOFTWARE (CORE MODULE)	L SUM	1.0	0.5		0.5	
X0326249	CARD CAGE CHASSIS	EACH	1.0	1.0			
X0326250	ATMS SOFTWARE (CAD MODULE - EAST PEORIA)	L SUM	1.0			1.0	
X0326251	ATMS SOFTWARE (CAD MODULE - PEORIA)	L SUM	1.0	1.0			
X0326252	COMPUTER WORKSTATION	EACH	13.0	11.0		2.0	
X0326253	LCD MONITOR	EACH	26.0	22.0		4.0	
X0326254	LAPTOP COMPUTER	EACH	4.0	4.0			
X0326255	APPLICATION SERVER	EACH	1.0	0.5		0.5	
X0326256	WEB SERVER	EACH	1.0	0.5		0.5	
X0326257	TAPE BACKUP UNIT	EACH	2.0	1.0		1.0	
X0326258	NETWORK SECURITY APPLIANCE	EACH	1.0	0.5		0.5	
X0326259	DIGITAL VIDEO ENCODER	EACH	12.0	12.0			
X0326260	ETHERNET SWITCH (MATERIAL ONLY)	EACH	1.0	1.0			
X0326261	KVM SWITCH	EACH	2.0	1.0		1.0	
X0326262	REMOTE POWER MANAGEMENT UNIT	EACH	10.0	6.0		4.0	
X0326263	EQUIPMENT CABINET	EACH	1.0	1.0			
X0326264	UPGRADE EXISTING ANALOG VIDEO SWITCH	L SUM	1.0	0.5		0.5	
X0326265	VIRUS SOFTWARE	L SUM	1.0	0.7		0.3	
X0326266	ETHERNET SWITCH	EACH	2.0	1.0		1.0	
X0326267	VIDEO SERVER	EACH	1.0	0.5		0.5	

FILE NAME =  
P:\RFP 8-3-08\68273 - ATMS Software Plots.dgn

USER NAME = howelder  
PLOT SCALE = 59.3319" / IN.  
PLOT DATE = 11/7/2008

DESIGNED - ---  
DRAWN - ---  
CHECKED - ---  
DATE - -----

REVISED - ---  
REVISED - ---  
REVISED - ---  
REVISED - ---

STATE OF ILLINOIS  
DEPARTMENT OF TRANSPORTATION

SUMMARY OF QUANTITIES

SCALE: \_\_\_\_\_ SHEET NO. \_\_\_ OF \_\_\_ SHEETS STA. \_\_\_\_\_ TO STA. \_\_\_\_\_

F.A.I. RTE.	SECTION	COUNTY	TOTAL SHEETS	SHEET NO.
74	D4 I-74 ITS SYSTEM-2	Peoria/Tozowell	20	3
CONTRACT NO. 68273				
FED. ROAD DIST. NO. ILLINOIS FED. AID PROJECT				

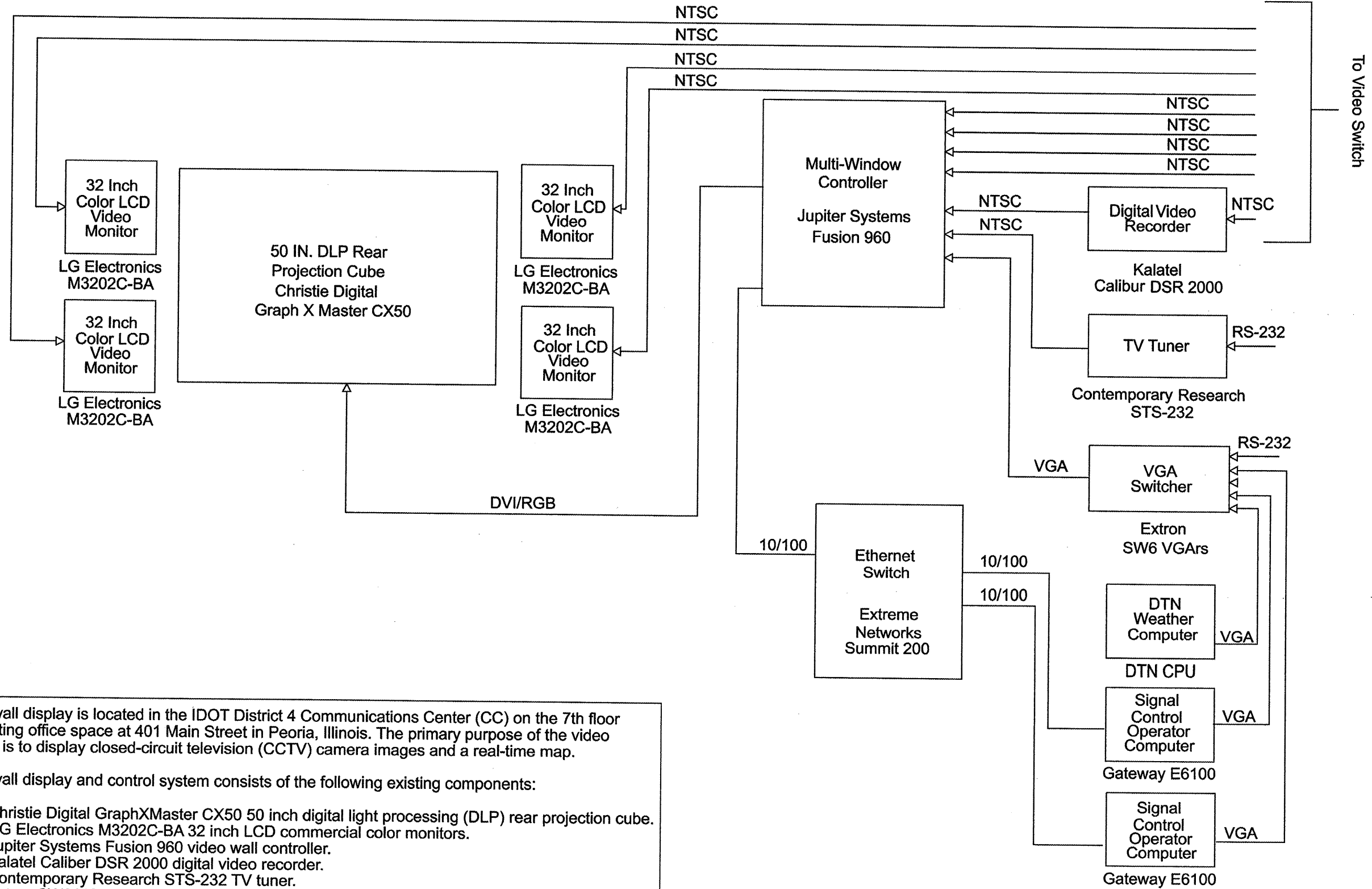

The video wall display is located in the IDOT District 4 Communications Center (CC) on the 7th floor of their existing office space at 401 Main Street in Peoria, Illinois. The primary purpose of the video wall display is to display closed-circuit television (CCTV) camera images and a real-time map.

The video wall display and control system consists of the following existing components:

- o One (1) Christie Digital GraphXMaster CX50 50 inch digital light processing (DLP) rear projection cube.
- o Four (4) LG Electronics M3202C-BA 32 inch LCD commercial color monitors.
- o One (1) Jupiter Systems Fusion 960 video wall controller.
- o One (1) Kalatel Caliber DSR 2000 digital video recorder.
- o One (1) Contemporary Research STS-232 TV tuner.
- o One (1) Extron SW6 VGA Switcher

FILE NAME *	USER NAME * #USER*	DESIGNED - ---	REVISED - ---	<b>STATE OF ILLINOIS DEPARTMENT OF TRANSPORTATION</b>	<b>EXISTING VIDEO SELECTION AND DISPLAY SCHEMATIC VIDEO WALL</b>	F.A.I. RTE.	SECTION	COUNTY	TOTAL SHEETS	SHEET NO.	
#FILE#		DRAWN - ---	REVISED - ---			74	D4 1-74 ITS SYSTEM-2	Peoria/Tazewell	20	4	
PLOT SCALE = #SCALE*		CHECKED - ---	REVISED - ---			<b>CONTRACT NO. 68273</b>					
PLOT DATE = #DATE*		DATE - ---	REVISED - ---			FED. ROAD DIST. NO. - ILLINOIS FED. AID PROJECT					

**CCTV - Wireless (Digital Video) Model**

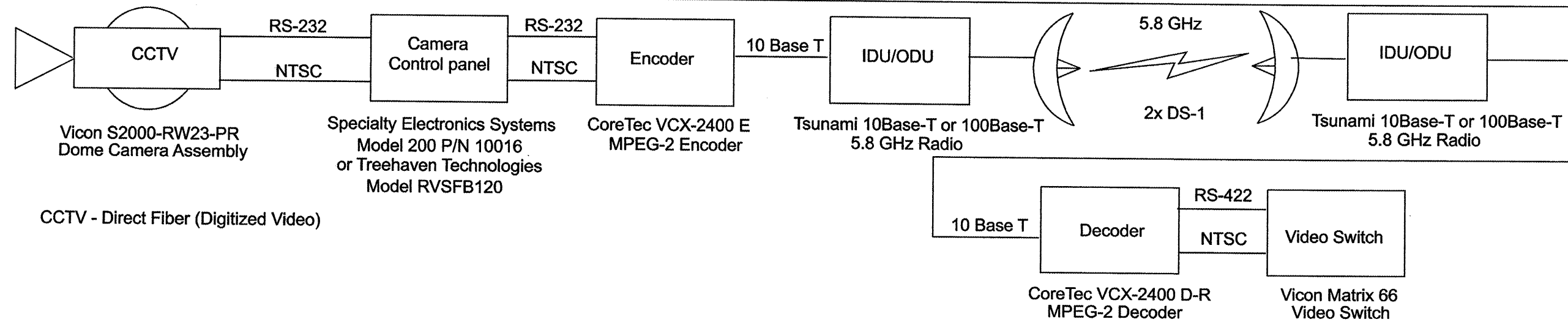

**CCTV - Direct Fiber (Digitized Video)**

**CCTV - Direct Fiber (Digital Video) Model**

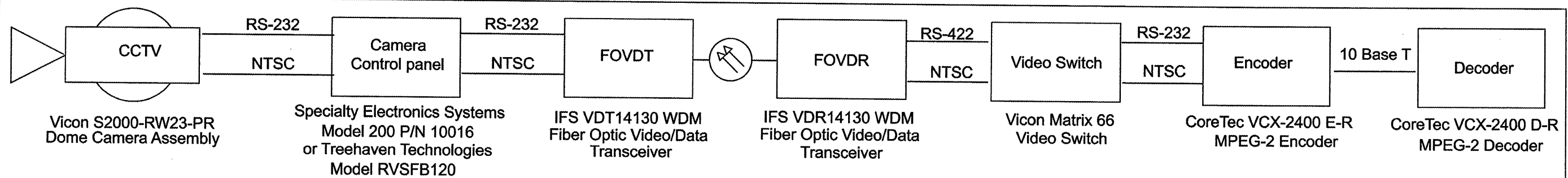

**CCTV - Direct Fiber (Analog Video) Model**

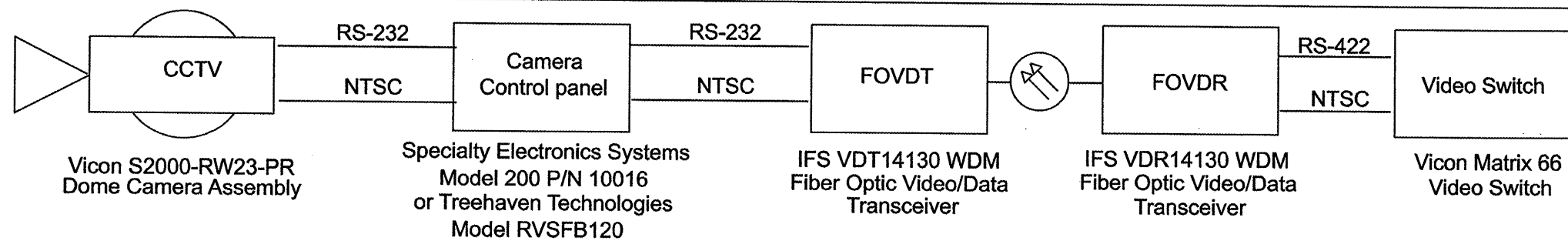

The camera control subsystem consists of four functional components: the video switch, the switch controller, the camera controller, and the joystick controllers.

**Video switch:** The existing video switch is a Vicon Matrix 66 high density video switching system. The purpose of the video switch is to electrically connect one or more output ports on the switch to an input port, under software control.

**Video switch controller & camera controller:** The video switch controller is comprised of two main items: an existing Vicon V1500CPU (Central Processing Unit) video switch processor and the existing Vicon V1500CDU (Communication Distribution Unit). The purpose of the switch controller is to accept commands from the user and configure the video switch to connect specific video inputs to specific video outputs. The purpose of the camera controller is to convert inputs from the operators to commands that are transmitted concurrently to the camera control receivers over low-speed data, multi-point circuits.

**Joystick controllers:** The existing joystick controller is a Vicon V1411X-DVC keypad controller. The purpose of the joystick controller is to allow users to control the video selection and control the camera pan/tilt/zoom (PTZ) orientation from remote locations via RS-422 communications.

**Closed Circuit Television (CCTV) Camera:** The system consists of twenty-five (25) permanent PTZ CCTV cameras installed in the field. The CCTV camera is a Vicon S2000-RS23-PR pressurized dome camera assembly. At each of the field locations, a Specialty Electronics Systems Local Camera Panel model 200 P/N 10016 or Treehaven Technologies, Model RVSFB120 is installed for combining camera video, control and power.

**Video encoder/decoder:** The existing video encoder is a Cortec VCX-2400-E and the existing video decoder is a Cortec VCX-2400-D. The purpose of the video encoder/decoder is to encode/decode video streams using MPEG-2 video compression.

FILE NAME =	USER NAME = #USER*	DESIGNED - ---	REVISED - ---	<b>STATE OF ILLINOIS DEPARTMENT OF TRANSPORTATION</b>	<b>EXISTING CAMERA CONTROL CCTV CAMERA CONTROL MODEL</b>	F.A.I. RTE.	SECTION	COUNTY	TOTAL SHEETS	SHEET NO.	
*FILEL*		DRAWN - ---	REVISED - ---			74	04 I-74 ITS SYSTEM-2	Peoria/Tazewell	20	5	
PLOT SCALE * #SCALE*		CHECKED - ---	REVISED - ---			<b>CONTRACT NO. 68273</b>					
PLOT DATE * #DATE*		DATE - -----	REVISED - ---			FED. ROAD DIST. NO. - ILLINOIS FED. AID PROJECT					

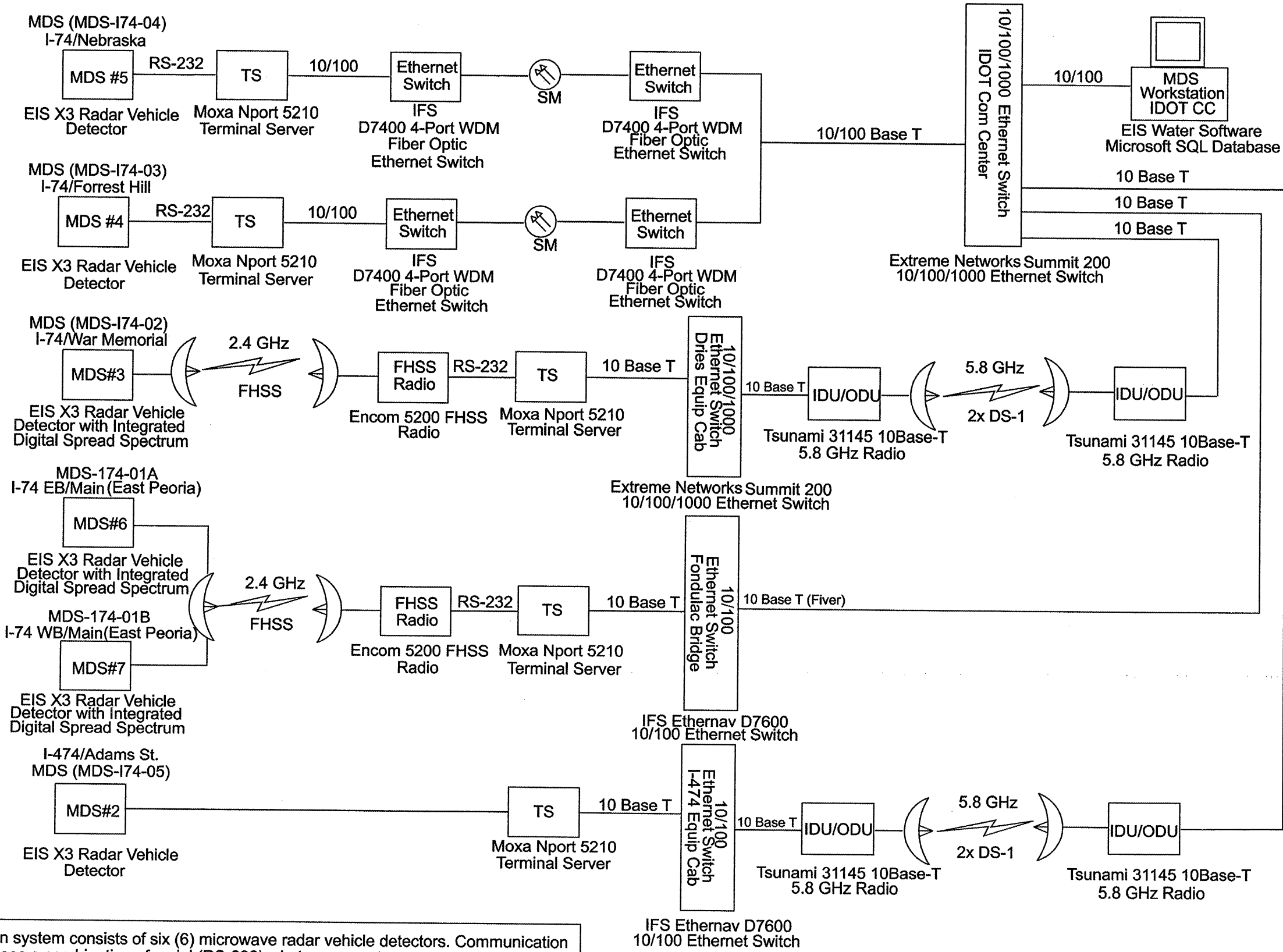

The traffic data collection system consists of six (6) microwave radar vehicle detectors. Communication to the radar detectors uses a combination of serial (RS-232) wireless spread spectrum and fiber optic communication. The wireless communication uses a combination of an Encom frequency hopping spread spectrum radio built into the RTMS unit and an Encom 5200 series radio.

FILE NAME *	USER NAME * #USER*	DESIGNED -	REVISED -	<b>STATE OF ILLINOIS DEPARTMENT OF TRANSPORTATION</b>	<b>EXISTING TRAFFIC DATA COLLECTION SCHEMATIC MICROWAVE DETECTOR STATIONS</b>	F.A.I. RTE.	SECTION	COUNTY	TOTAL SHEETS	SHEET NO.	
#FILEL*		DRAWN -	REVISED -			74	D4 I-74 ITS SYSTEM-2	Peoria/Tazewell	20	6	
PLOT SCALE * #SCALE*		CHECKED -	REVISED -			<b>CONTRACT NO. 68273</b>					
PLOT DATE * #DATE*		DATE -	REVISED -			FED. ROAD DIST. NO. - ILLINOIS FED. AID PROJECT					

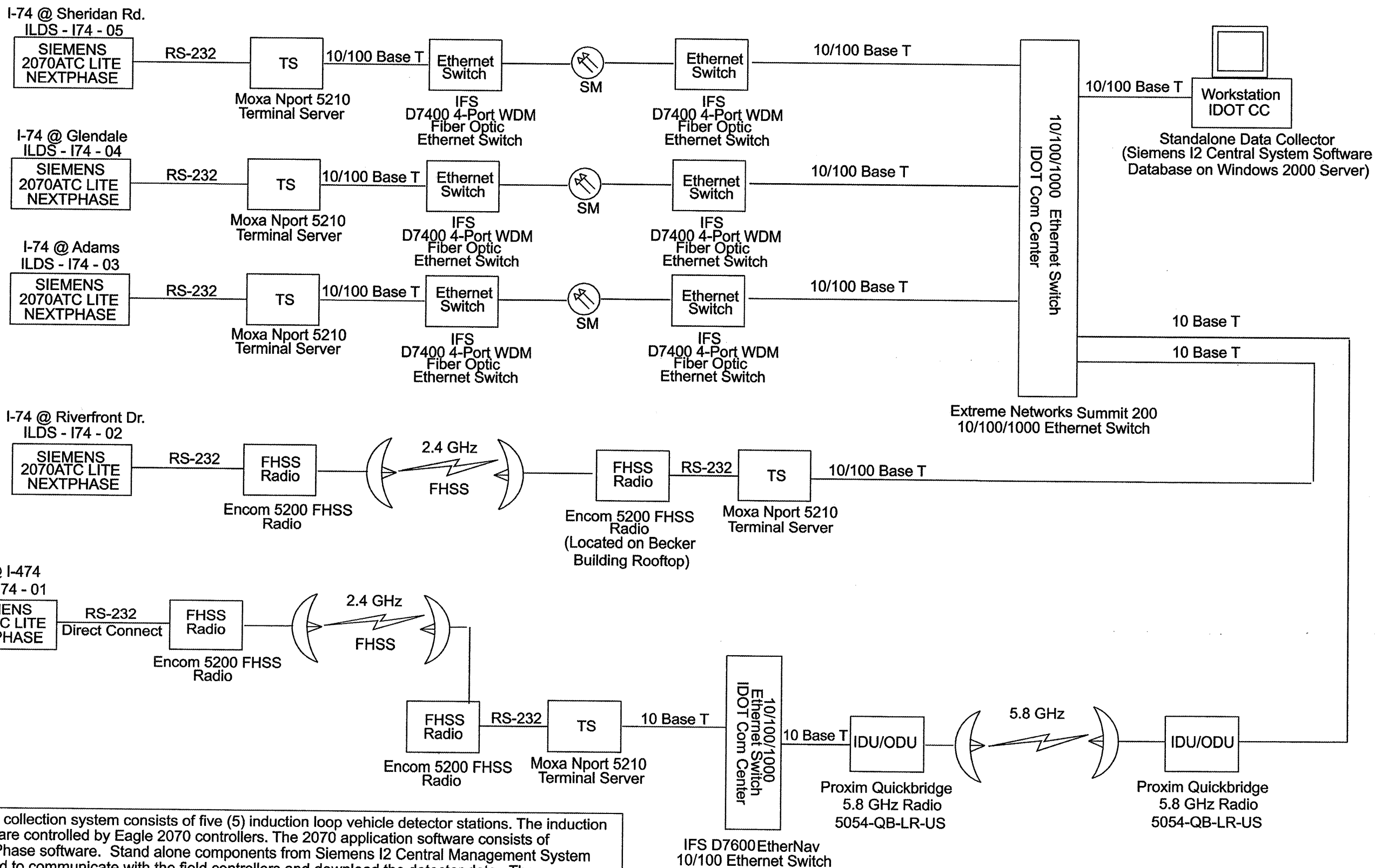

The traffic data collection system consists of five (5) induction loop vehicle detector stations. The induction loop detectors are controlled by Eagle 2070 controllers. The 2070 application software consists of Siemens NextPhase software. Stand alone components from Siemens I2 Central Management System software is used to communicate with the field controllers and download the detector data. The communication interface to the 2070 controller is RS-232 using serial to Ethernet terminal servers. Network connectivity from the field to the IDOT CC uses a combination of wireless spread spectrum and fiber optic communication. The wireless communication uses an Encom 5200 series frequency hopping spread spectrum radio.

FILE NAME =	USER NAME = #USERS	DESIGNED -	REVISED -	<b>STATE OF ILLINOIS DEPARTMENT OF TRANSPORTATION</b>	<b>EXISTING TRAFFIC DATA COLLECTION SCHEMATIC INDUCTIVE LOOP DETECTOR STATIONS</b>	F.A.I. RTE.	SECTION	COUNTY	TOTAL SHEETS	SHEET NO.	
#FILEL#		DRAWN -	REVISED -			74	D4 I-74 ITS SYSTEM-2	Peoria/Tazewell	20	7	
		CHECKED -	REVISED -			<b>CONTRACT NO. 68273</b>					
		DATE -	REVISED -			FED. ROAD DIST. NO. - ILLINOIS FED. AID PROJECT					

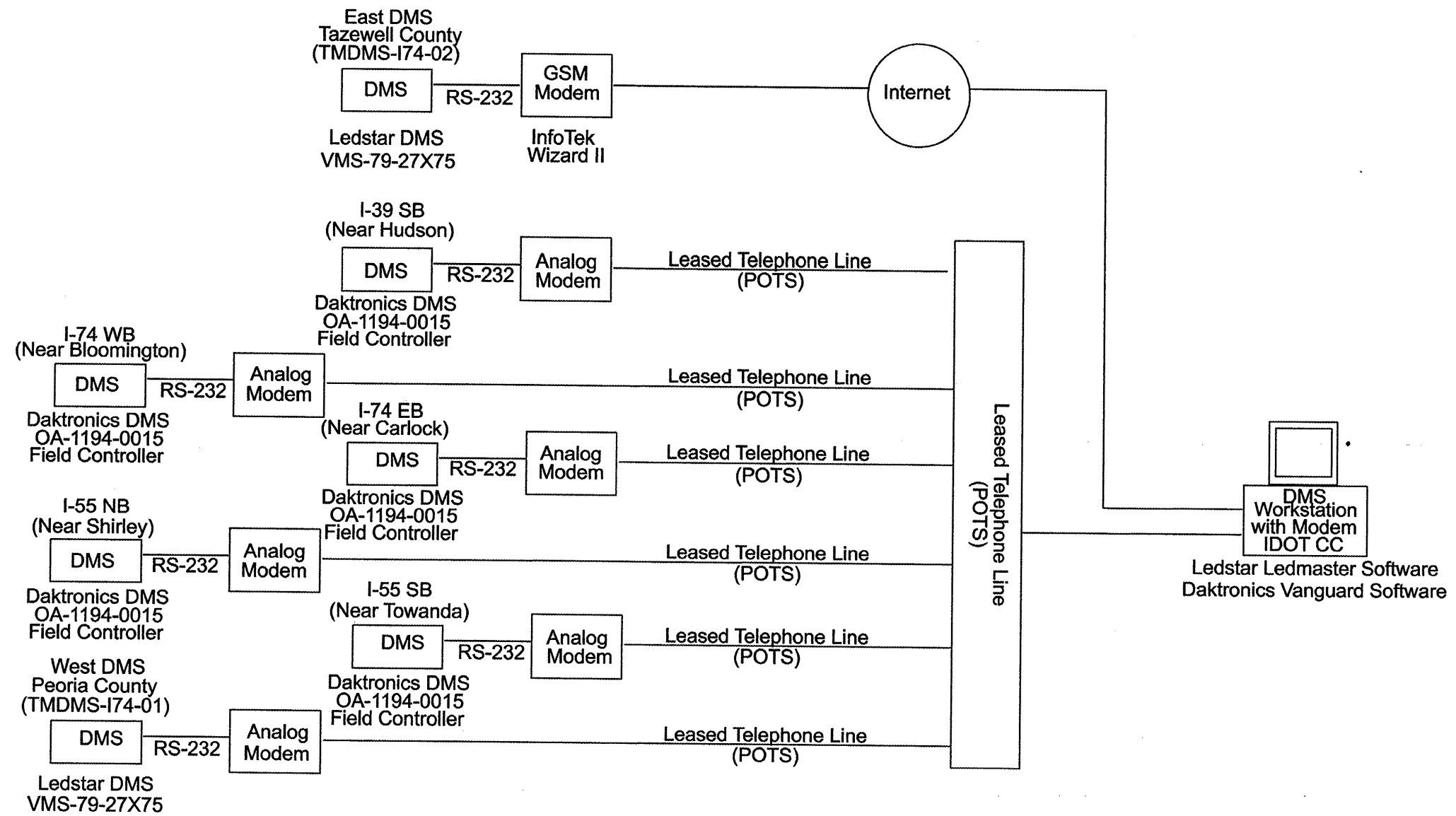

There are two Ledstar VMS-79-27X75 dynamic message signs used as part of the final ITS system. The east sign is located east of the I-74/I-474 interchange along I-74 near Muller Rd. Communication to the sign uses an InfoTek Wizard II wireless GSM modem. The other sign is located on I-74 west of Heinz Road. Communication to the sign uses an Addco analog serial modem over a standard leased telephone line (POTS).

Additionally, there are a total of five Daktronics signs located in McClean County along I-74, I-39, and I-55 that are currently controlled from the IDOT CC. The sign controllers support NTCIP communications. Communication to the signs use analog modems over leased telephone lines (POTS).

FILE NAME *	USER NAME * #USER*	DESIGNED -	REVISED -	<b>STATE OF ILLINOIS DEPARTMENT OF TRANSPORTATION</b>	<b>EXISTING DYNAMIC MESSAGE SIGN (DMS)SCHEMATIC</b>	F.A.I. RTE.	SECTION	COUNTY	TOTAL SHEETS	SHEET NO.	
*FILE#		DRAWN -	REVISED -			74	D4 I-74 ITS SYSTEM-2	Peoria/Tazewell	20	8	
		CHECKED -	REVISED -			<b>CONTRACT NO. 68273</b>					
		DATE -	REVISED -			FED. ROAD DIST. NO. ILLINOIS FED. AID PROJECT					
				SCALE: _____ SHEET NO. ____ OF ____ SHEETS STA. _____ TO STA. _____							



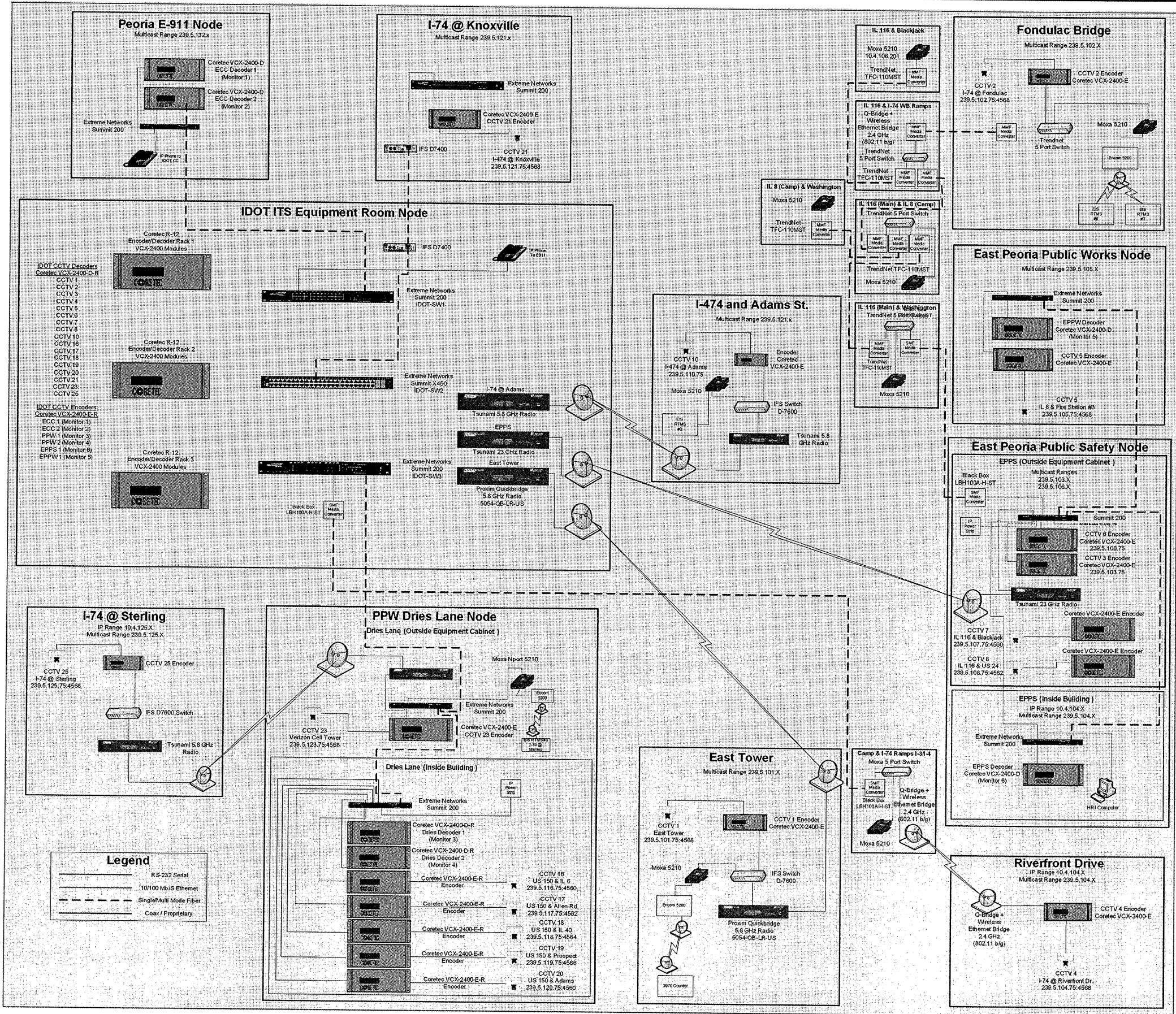

FILE NAME *	USER NAME * #USER#	DESIGNED - ---	REVISED - ---
#FILE#		DRAWN - ---	REVISED - ---
	PLOT SCALE * #SCALE#	CHECKED - ---	REVISED - ---
	PLOT DATE * #DATE#	DATE - -----	REVISED - ---

**STATE OF ILLINOIS  
DEPARTMENT OF TRANSPORTATION**

<b>EXISTING ETHERNET NETWORK SCHEMATIC</b>			
SCALE: -----	SHEET NO. -- OF --- SHEETS	STA. -----	TC STA. -----

F.A.I. RTE.	SECTION	COUNTY	TOTAL SHEETS	SHEET NO.
74	D4 I-74 ITS SYSTEM-2	Peoria/Tazewell	20	9
CONTRACT NO. 68273				
FED. ROAD DIST. NO. [ILLINOIS] FED. AID PROJECT				

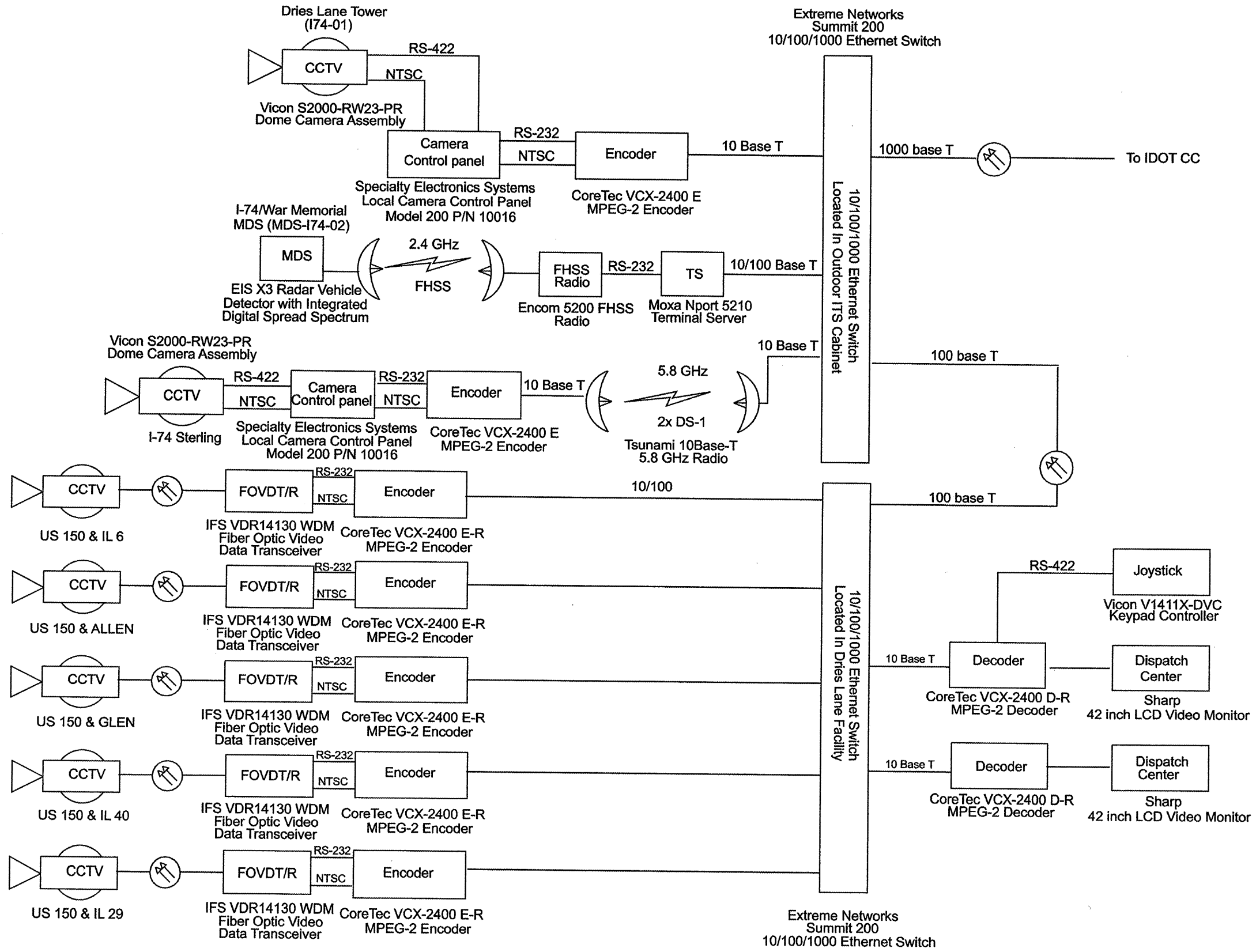

FILE NAME = #FILE#	USER NAME = #USER#	DESIGNED - ----	REVISED - ----	<b>STATE OF ILLINOIS DEPARTMENT OF TRANSPORTATION</b>	<b>EXISTING DATA NETWORK SCHEMATIC PEORIA DEPARTMENT OF PUBLIC WORKS (PPW)</b>	F.A.I. RTE.	SECTION	COUNTY	TOTAL SHEETS	SHEET NO.	
	PLOT SCALE = #SCALE#	DRAWN - ----	REVISED - ----			74	D4 I-74 ITS SYSTEM-2	Peoria/Tazewell	20	10	
	PLOT DATE = #DATE#	CHECKED - ----	REVISED - ----			<b>CONTRACT NO. 68273</b>					
		DATE - ----	REVISED - ----			FED. ROAD DIST. NO. - ILLINOIS FED. AID PROJECT					

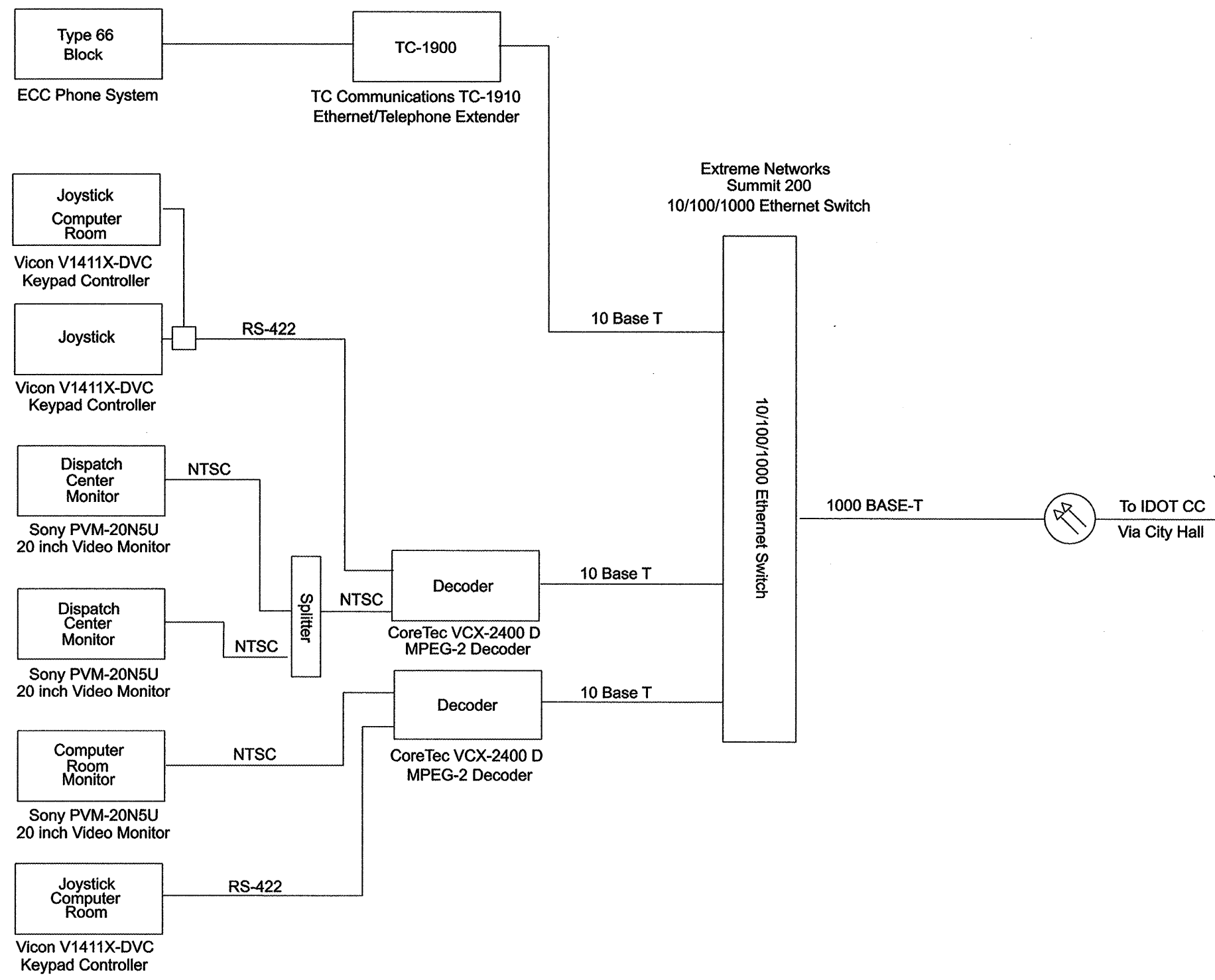

The Peoria ECC has several CCTV PTZ controllers and video monitors for displaying video. The Peoria ECC is connected to the IDOT CC by a fiber optic Gigabit Ethernet link.

FILE NAME = P:\RFP 8-3-08\68273 - ATMS Software Pla	USER NAME = howelder	DESIGNED - ---	REVISED - ---	<b>STATE OF ILLINOIS DEPARTMENT OF TRANSPORTATION</b>	<b>EXISTING DATA NETWORK SCHEMATIC PEORIA EMERGENCY COMMUNICATION CANETER (ECC)</b>			F.A.I. RTE.	SECTION	COUNTY	TOTAL SHEETS	SHEET NO.
		DRAWN - ---	REVISED - ---		SCALE: -----	SHEET NO. -- OF --- SHEETS	STA. ----- TO STA. -----	74	D4 I-74 ITS SYSTEM-2	Peoria/Tazewell	20	11
		CHECKED - ---	REVISED - ---					CONTRACT NO. 68273				
		DATE - -----	REVISED - ---		FED. ROAD DIST. NO. - ILLINOIS FED. AID PROJECT							

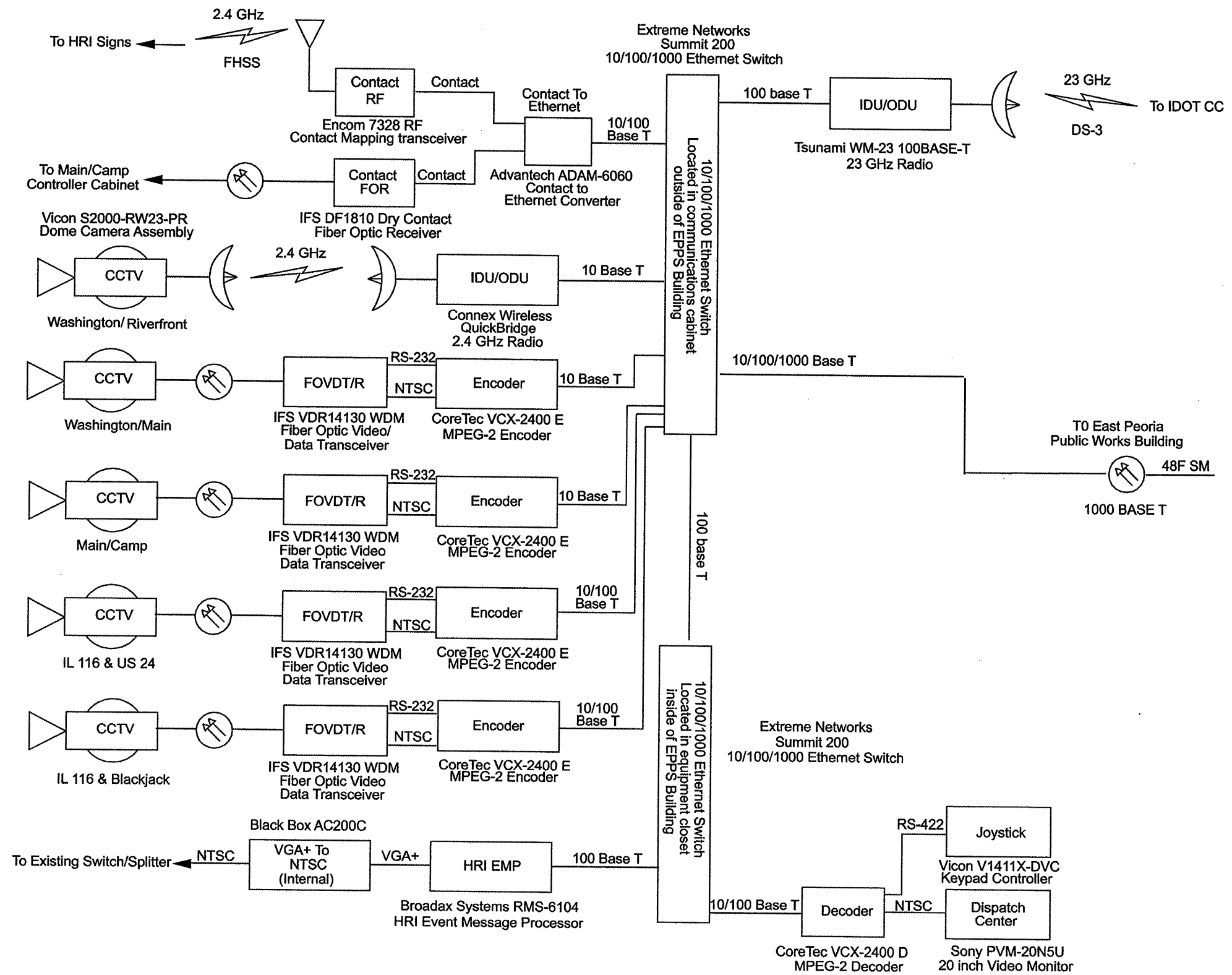

The EPPS site collects several CCTV camera video feeds and is equipped with a video monitor and a CCTV PTZ controller. The site also contains the Highway Railroad Information (HRI) equipment. The site is connected to the IDOT CC via a 23 GHz DS-3 microwave link.

FILE NAME * *FILE*	USER NAME * *USER*	DESIGNED - ---	REVISED - ---	<b>STATE OF ILLINOIS DEPARTMENT OF TRANSPORTATION</b>	<b>EXISTING DATA NETWORK SCHEMATIC EAST PEORIA PUBLIC SAFETY (EPPS)</b>	F.A.I. RTE.	SECTION	COUNTY	TOTAL SHEETS	SHEET NO.	
	PLOT SCALE * *SCALE*	DRAWN - ---	REVISED - ---			74	D4 1-74 ITS SYSTEM-2	Peoria/Tazewell	20	12	
	PLOT DATE * *DATE*	CHECKED - ---	REVISED - ---			<b>CONTRACT NO. 68273</b>					
		DATE - -----	REVISED - ---			FED. ROAD DIST. NO. - ILLINOIS FED. AID PROJECT					

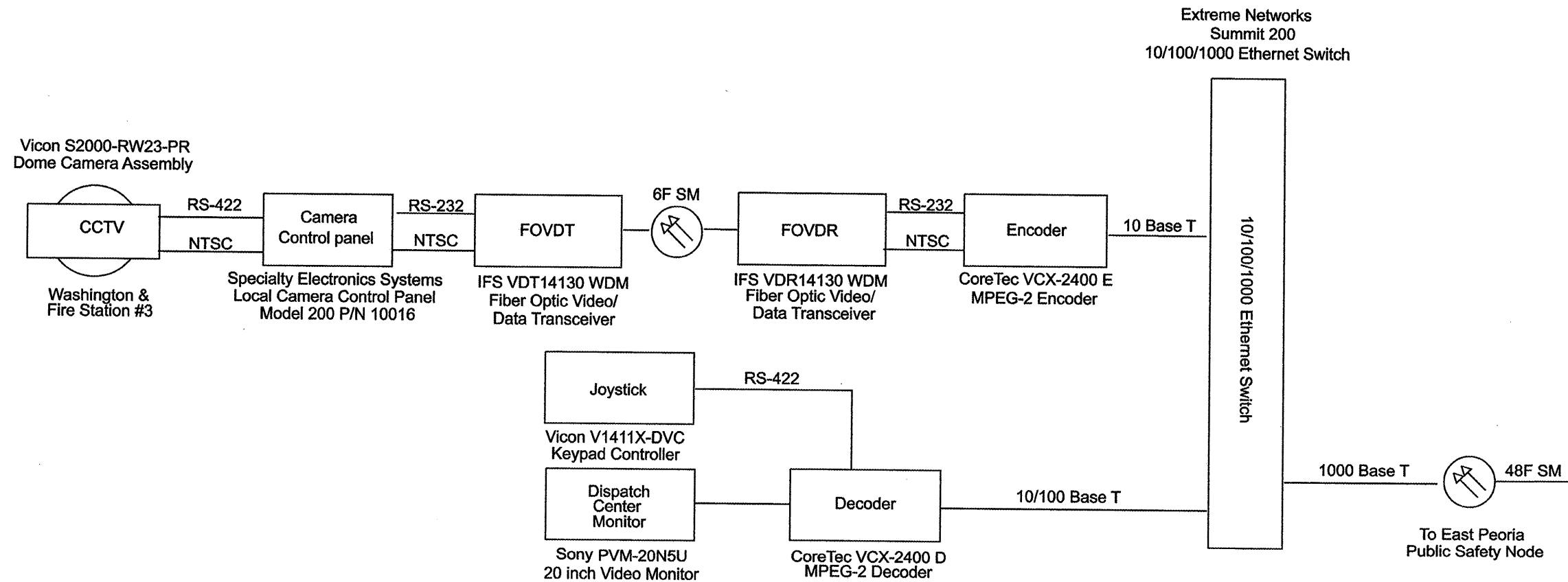

The EPPW is a full ITS node with a Gigabit Ethernet backbone installed between EPPS and EPPW. The node contains a camera joystick, monitor, and video decoder.

FILE NAME *	USER NAME * #USER*	DESIGNED -	REVISED -	<b>STATE OF ILLINOIS DEPARTMENT OF TRANSPORTATION</b>	<b>EXISTING DATA NETWORK SCHEMATIC EAST PEORIA PUBLIC WORKS (EPPW)</b>	F.A.I. RTE.	SECTION	COUNTY	TOTAL SHEETS	SHEET NO.	
#FILE#		DRAWN -	REVISED -			74	D4 I-74 ITS SYSTEM-2	Peoria/Tozwell	20	13	
PLOT SCALE = #SCALE*		CHECKED -	REVISED -			<b>CONTRACT NO. 68273</b>					
PLOT DATE * #DATE*		DATE -	REVISED -			FED. ROAD DIST. NO. - ILLINOIS FED. AID PROJECT					
					SCALE: _____	SHEET NO. ___ OF ___ SHEETS		STA. _____ TO STA. _____			

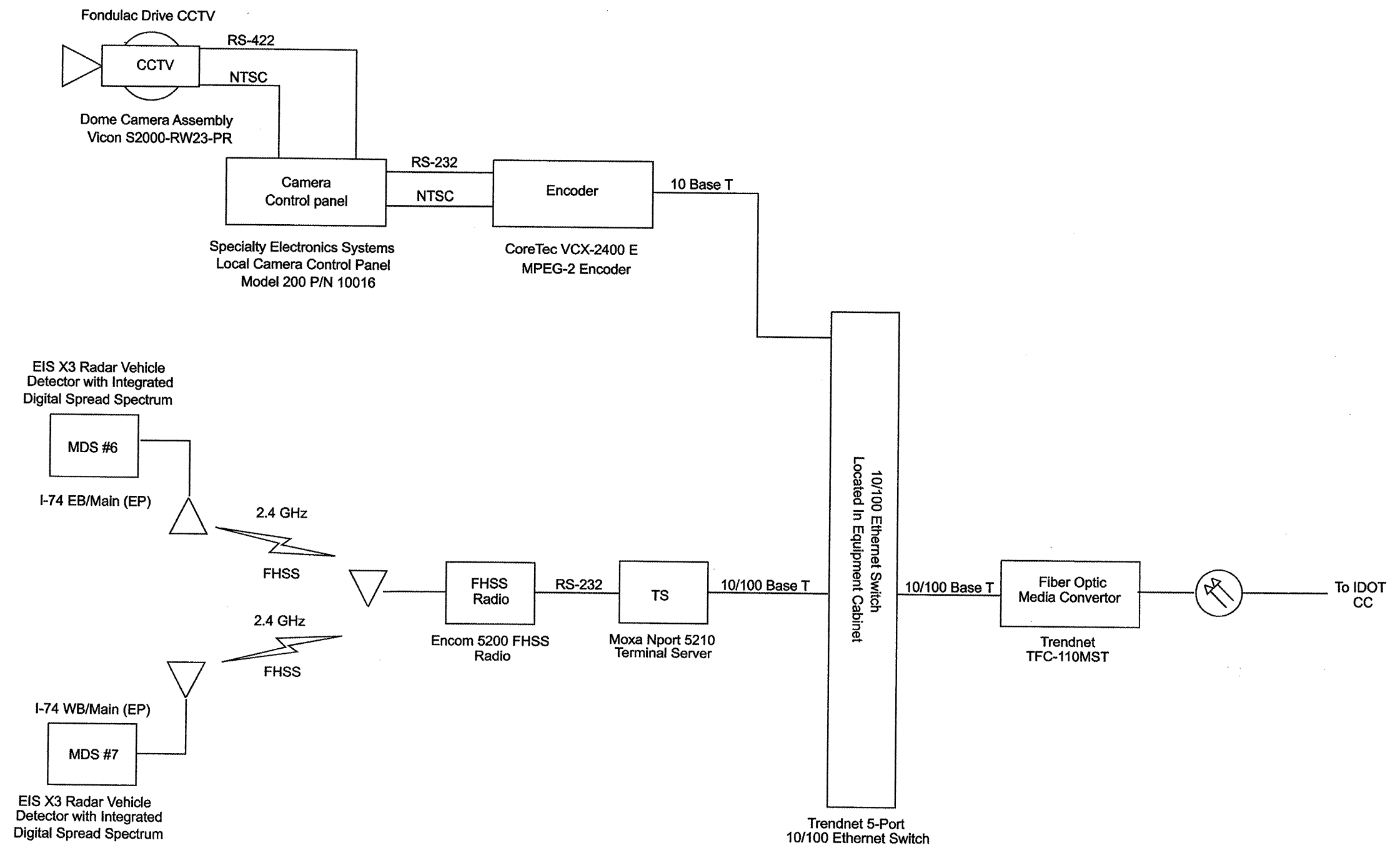

The Fondulac bridge site collects traffic data from remote microwave detector sites. The site also has a single CCTV camera installed on a pole that is attached to the Fondulac bridge. Both the traffic data and CCTV video are transported to the IDOT CC by a 5.8 GHz microwave link.

FILE NAME =	USER NAME = *USER*	DESIGNED -	REVISED -	<b>STATE OF ILLINOIS DEPARTMENT OF TRANSPORTATION</b>	<b>EXISTING DATA NETWORK SCHEMATIC I-74 @ FONDULAC BRIDGE</b>	F.A.I. RTE.	SECTION	COUNTY	TOTAL SHEETS	SHEET NO.	
#FILE#		DRAWN -	REVISED -			74	D4 I-74 ITS SYSTEM-2	Pearla/Tazewell	20	14	
	PLOT SCALE = *SCALE*	CHECKED -	REVISED -			<b>CONTRACT NO. 68273</b>					
	PLOT DATE = *DATE*	DATE -	REVISED -			FED. ROAD DIST. NO. - ILLINOIS FED. AID PROJECT					

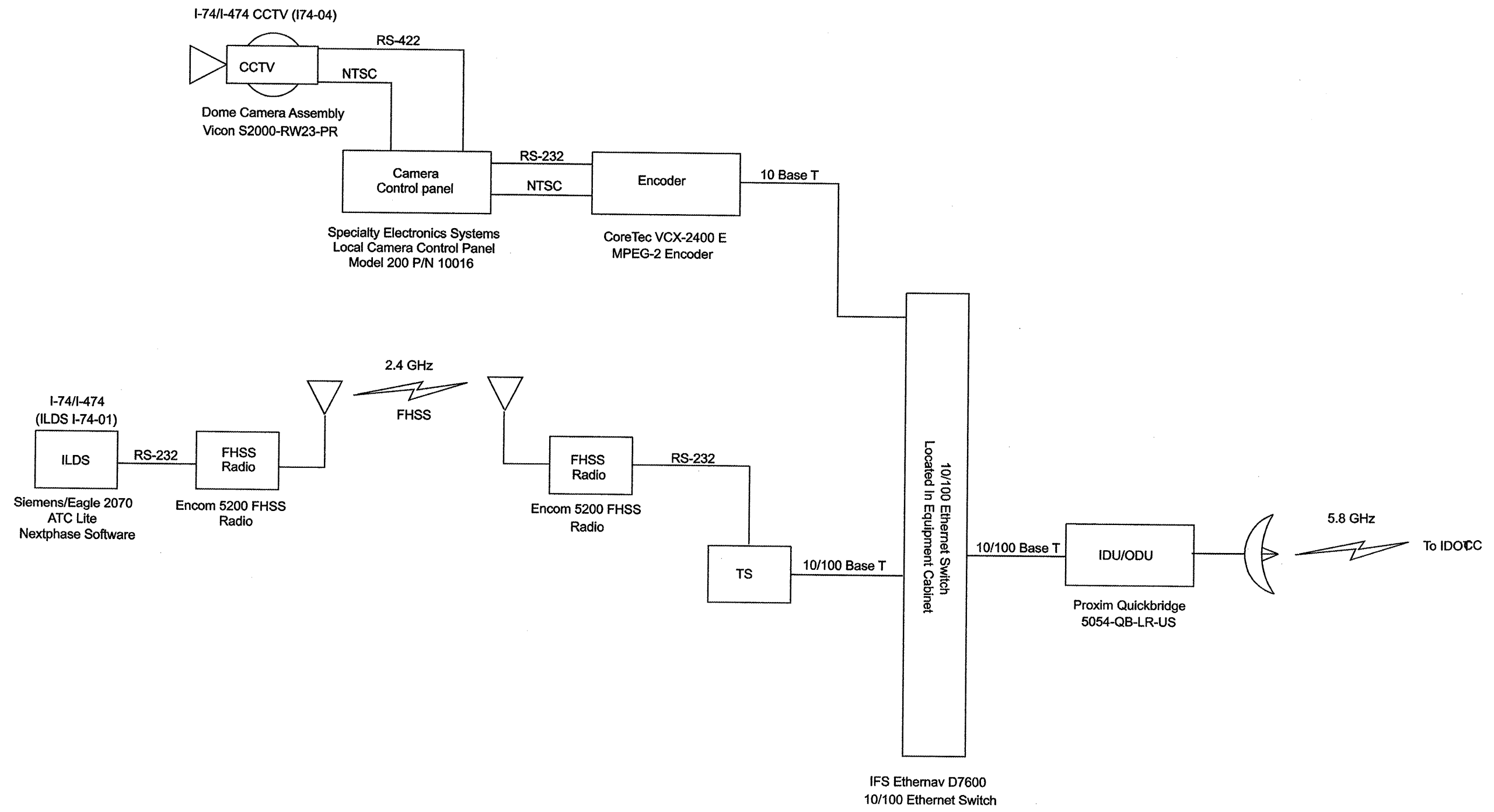

The East Tower is located along I-74 near the I-474 interchange. This site collects traffic data from one inductive loop detector site and has a single CCTV camera installed on the communication tower. The traffic data and CCTV video are transported to the IDOT CC by a 5.8 GHz microwave link.

FILE NAME *	USER NAME * #USER*	DESIGNED - ---	REVISED - ---	<b>STATE OF ILLINOIS DEPARTMENT OF TRANSPORTATION</b>	<b>EXISTING DATA NETWORK SCHEMATIC I-74 @ I-474 EAST TOWER</b>	F.A.I. RTE.	SECTION	COUNTY	TOTAL SHEETS	SHEET NO.	
*FILE#	PLOT SCALE * #SCALE*	DRAWN - ---	REVISED - ---			74	D4 I-74 ITS SYSTEM-2	Peoria/Tozowell	20	15	
	PLOT DATE * #DATE*	CHECKED - ---	REVISED - ---			<b>CONTRACT NO. 68273</b>					
		DATE - -----	REVISED - ---			FED. ROAD DIST. NO. - [ILLINOIS] FED. AID PROJECT					
					SCALE: -----	SHEET NO. -- OF --- SHEETS		STA. ----- TO STA. -----			

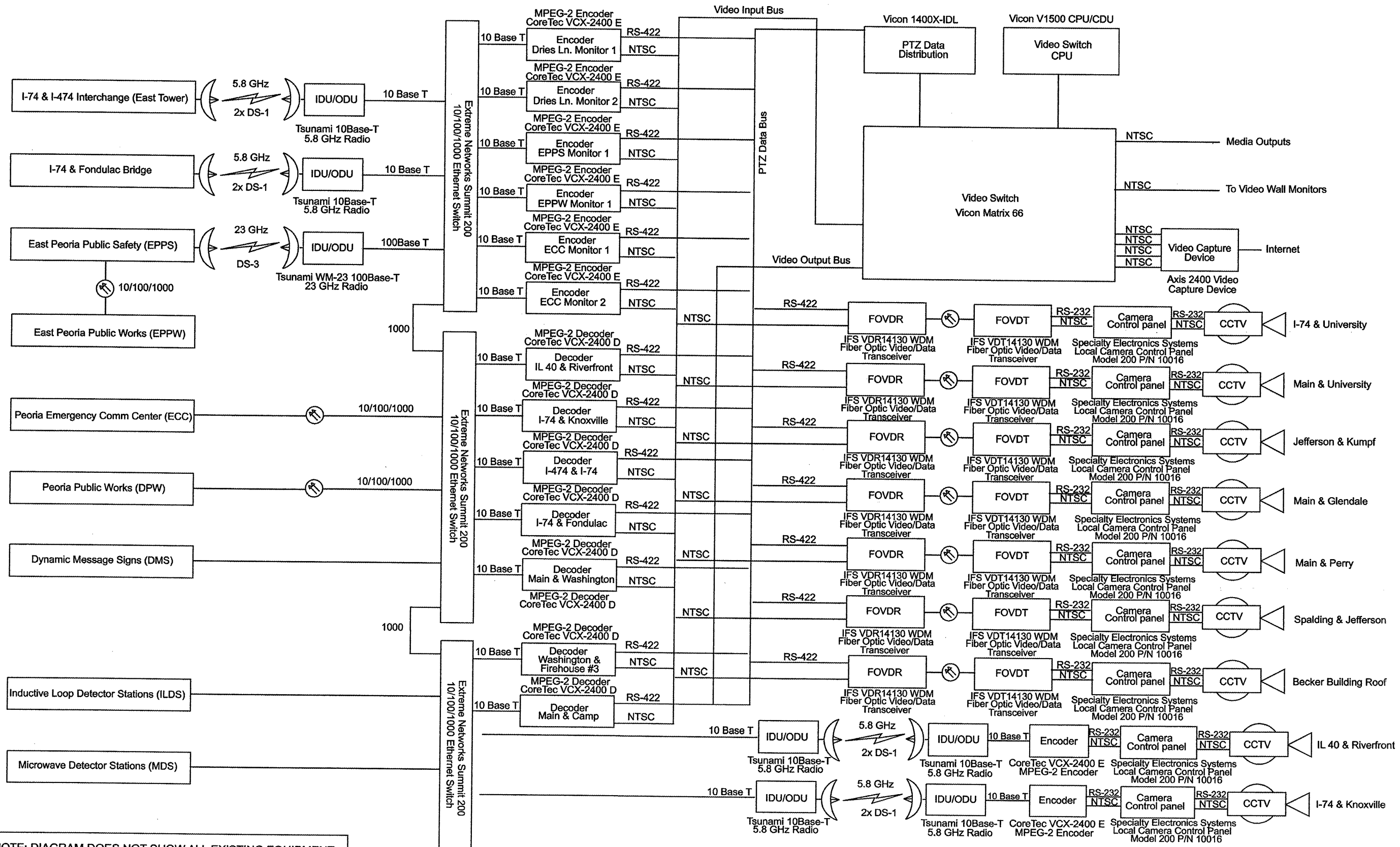

NOTE: DIAGRAM DOES NOT SHOW ALL EXISTING EQUIPMENT.

FILE NAME * #FILE#	USER NAME * USER*	DESIGNED - ---	REVISED - ---	<b>STATE OF ILLINOIS DEPARTMENT OF TRANSPORTATION</b>	<b>EXISTING DATA NETWORK SCHEMATIC IDOT COMMUNICATIONS CENTER</b>	F.A.I. RTE.	SECTION	COUNTY	TOTAL SHEETS	SHEET NO.	
	PLOT SCALE * #SCALE*	DRAWN - ---	REVISED - ---			74	D4 I-74 ITS SYSTEM-2	Peoria/Tozawa	20	16	
	PLOT DATE * #DATE*	CHECKED - ---	REVISED - ---			<b>CONTRACT NO. 68273</b>					
		DATE - ---	REVISED - ---			FED. ROAD DIST. NO. - ILLINOIS FED. AID PROJECT					



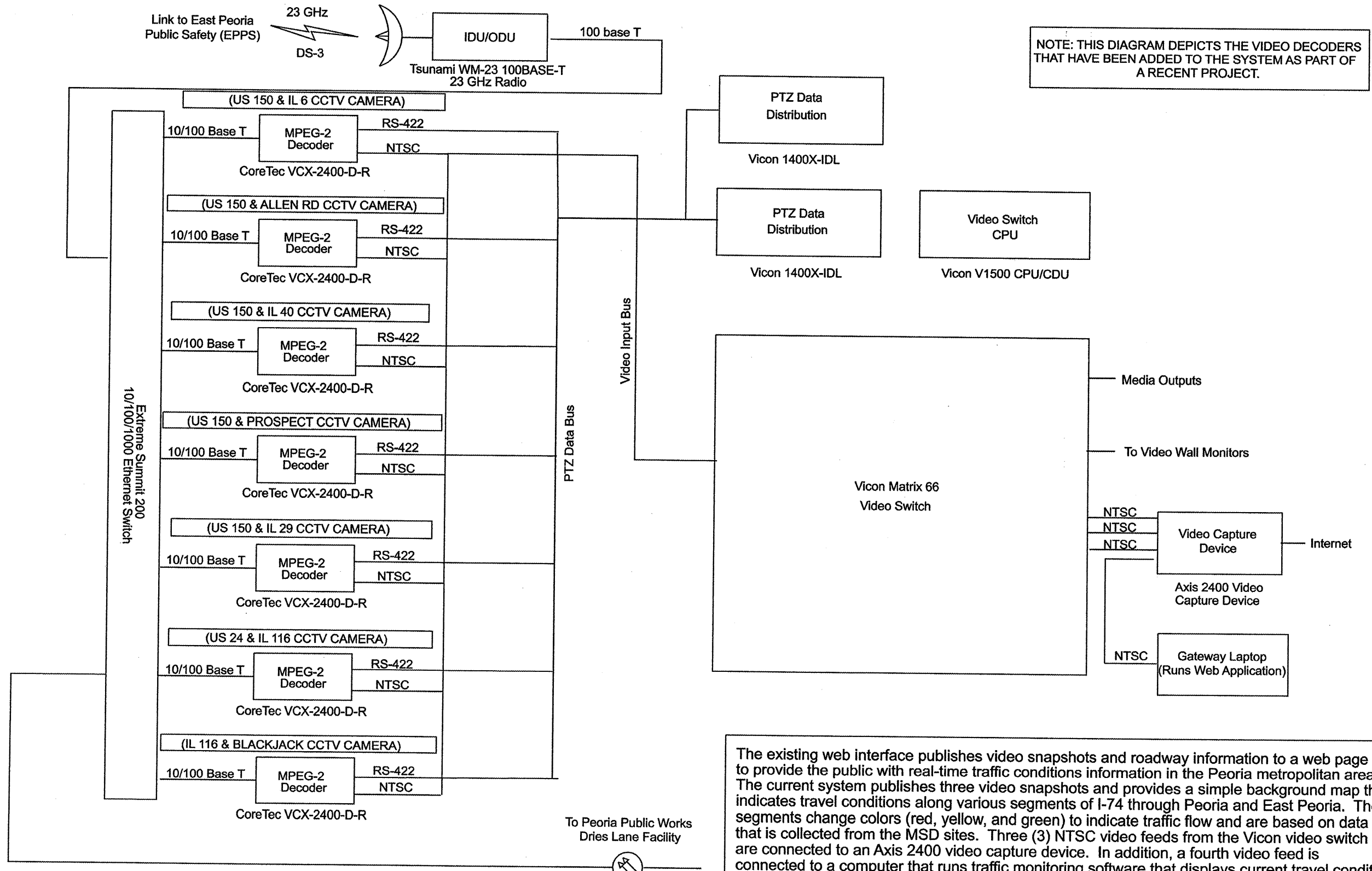

NOTE: THIS DIAGRAM DEPICTS THE VIDEO DECODERS THAT HAVE BEEN ADDED TO THE SYSTEM AS PART OF A RECENT PROJECT.

NOTE: DIAGRAM DOES NOT SHOW ALL EXISTING EQUIPMENT.

The existing web interface publishes video snapshots and roadway information to a web page to provide the public with real-time traffic conditions information in the Peoria metropolitan area. The current system publishes three video snapshots and provides a simple background map that indicates travel conditions along various segments of I-74 through Peoria and East Peoria. The segments change colors (red, yellow, and green) to indicate traffic flow and are based on data that is collected from the MSD sites. Three (3) NTSC video feeds from the Vicon video switch are connected to an Axis 2400 video capture device. In addition, a fourth video feed is connected to a computer that runs traffic monitoring software that displays current travel conditions. This existing component will not need to be integrated into the ATMS software as this functionality will be replaced in its entirety by the ATMS software (see requirements section for more information).

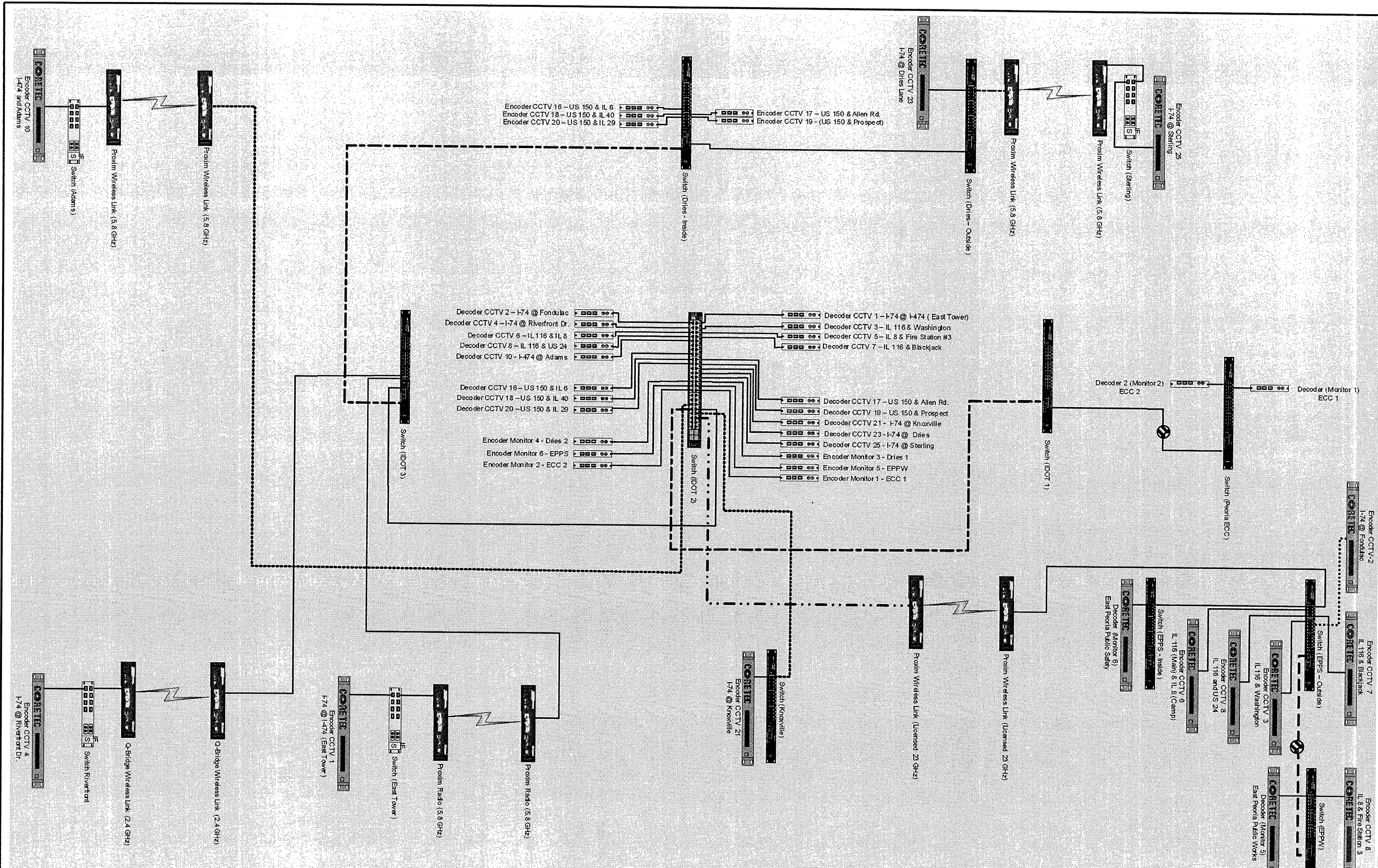

FILE NAME = #FILE#	USER NAME = #USER#	DESIGNED - DRAWN - CHECKED - DATE -	REVISED - REVISED - REVISED - REVISED -
	PLOT SCALE = #SCALE#		
	PLOT DATE = #DATE#		

**STATE OF ILLINOIS  
DEPARTMENT OF TRANSPORTATION**

<b>VIDEO SUBSYSTEM NETWORK SCHEMATIC</b>	
SCALE: _____	SHEET NO. ____ OF ____ SHEETS STA. _____ TO STA. _____

F.A.I. RTE.	SECTION	COUNTY	TOTAL SHEETS	SHEET NO.
74	D4 I-74 ITS SYSTEM-2	Peoria/Tazewell	20	17A
<b>CONTRACT NO. 68273</b>				
FED. ROAD DIST. NO. - ILLINOIS FED. AID PROJECT				

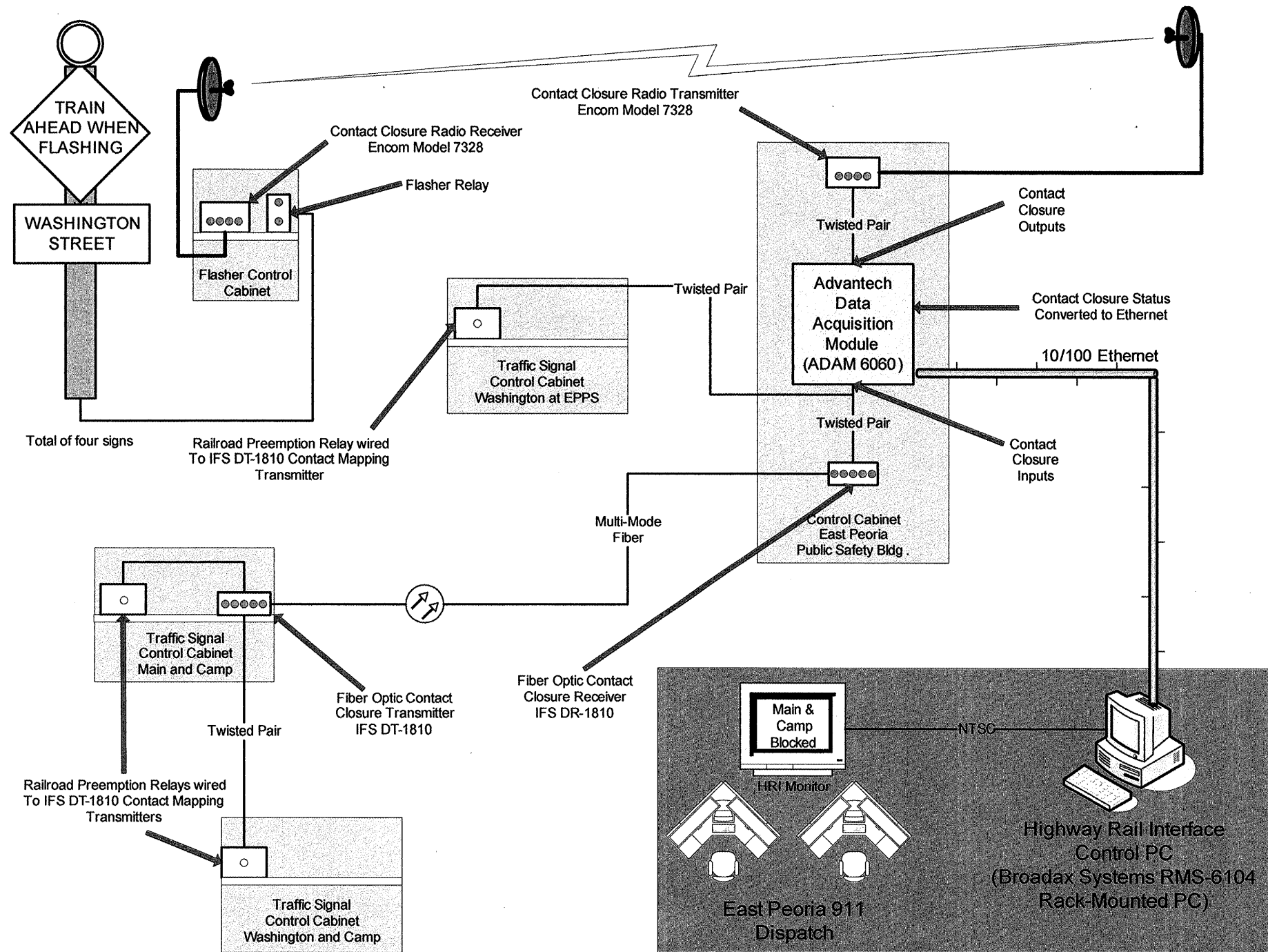

The HRI system informs approaching motorists of potential delays due to a blocked at-grade railroad crossing at the Washington Street and Camp Street (IL Route 8), Main Street and Camp Street, or the Washington Street (adjacent to the East Peoria Public Safety Building) railroad crossings. This advisory warning is communicated to approaching motorists using a flashing beacon that is placed above a static advanced warning sign.

The HRI system transmits the railroad crossing blocking contact closure status from the traffic signal controllers to a communications cabinet at the East Peoria Public Safety building via fiber optic cable (IFS DT-1810 and DR-1810). The contact closures status are read in by an Ethernet to contact closure converter (Advantech ADAM6060) and processed by an event message processor (Broadax Systems RMS-6104 rack mounted computer). The Modbus communication protocol over Ethernet is used to communicate between the Ethernet to contact closure converter and event message processor. A response based on the inputs is formulated and is transmitted to the appropriate HRI signs via the Ethernet to contact closure converter and wireless contact mapping transmitter and receivers (Encom 7328).

A visual display is shown on a video monitor at the East Peoria Public Safety Building to provide operators with status information on each of the monitored at-grade crossings.

# Proposed ATMS (ITS) Network

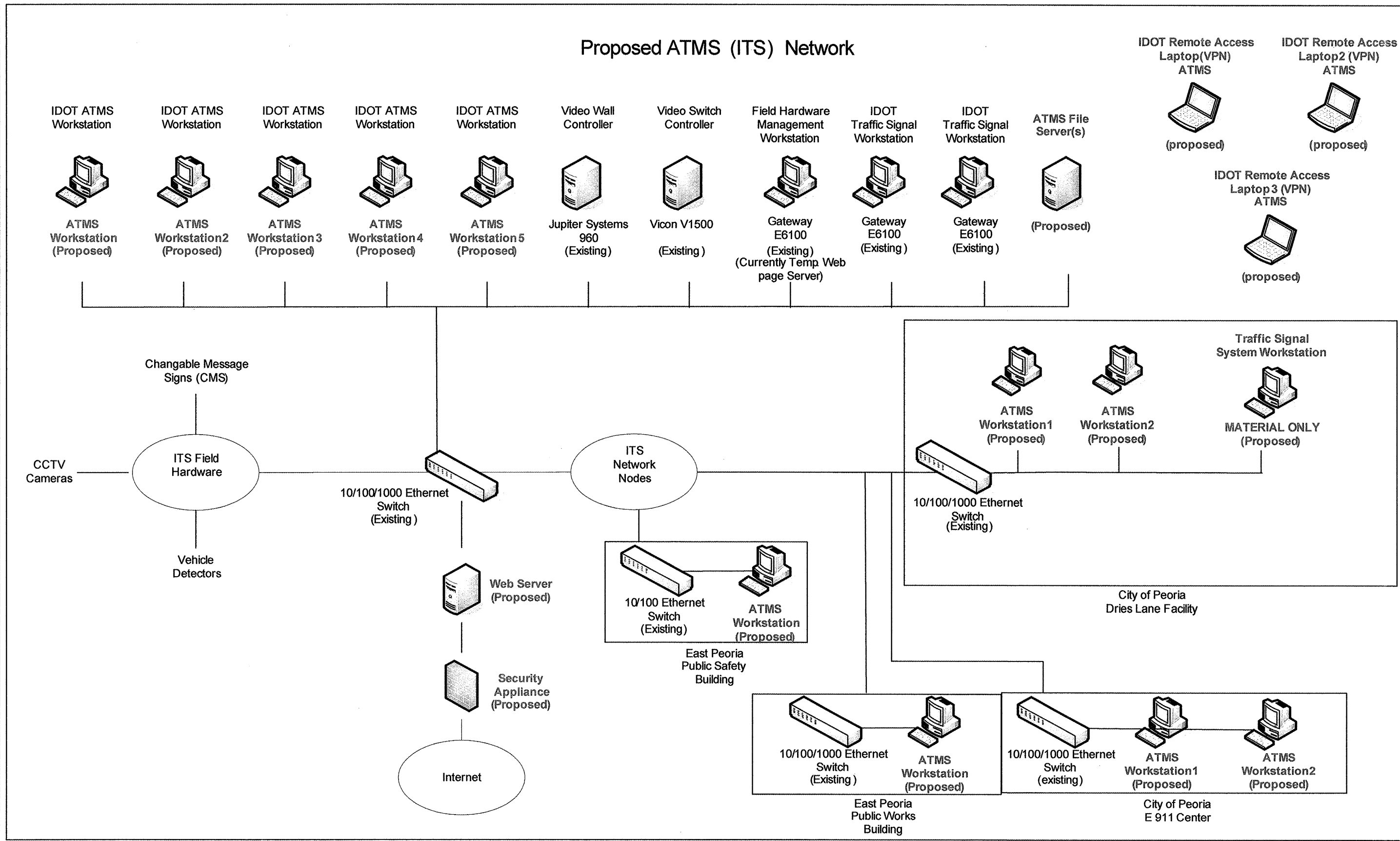

FILE NAME = P:\RFP 0-3-08\68273 - ATMS Software Plan.dgn	USER NAME = howelder	DESIGNED - ---	REVISED - ---
		DRAWN - ---	REVISED - ---
		CHECKED - ---	REVISED - ---
		DATE - ---	REVISED - ---
PLOT SCALE = 59.1652' / IN.		PLOT DATE = 11/7/2008	

**STATE OF ILLINOIS  
DEPARTMENT OF TRANSPORTATION**

**EXISTING ITS NETWORK SCHEMATIC**

SCALE: \_\_\_\_\_ SHEET NO. \_\_\_ OF \_\_\_ SHEETS STA. \_\_\_\_\_ TO STA. \_\_\_\_\_

F.A.I. RTE.	SECTION	COUNTY	TOTAL SHEETS	SHEET NO.
74	D4 I-74 ITS SYSTEM-2	Peoria/Tozwell	20	19
CONTRACT NO. 68273				
FED. ROAD DIST. NO. _____ ILLINOIS FED. AID PROJECT				

# Proposed ATMS (ITS) Network

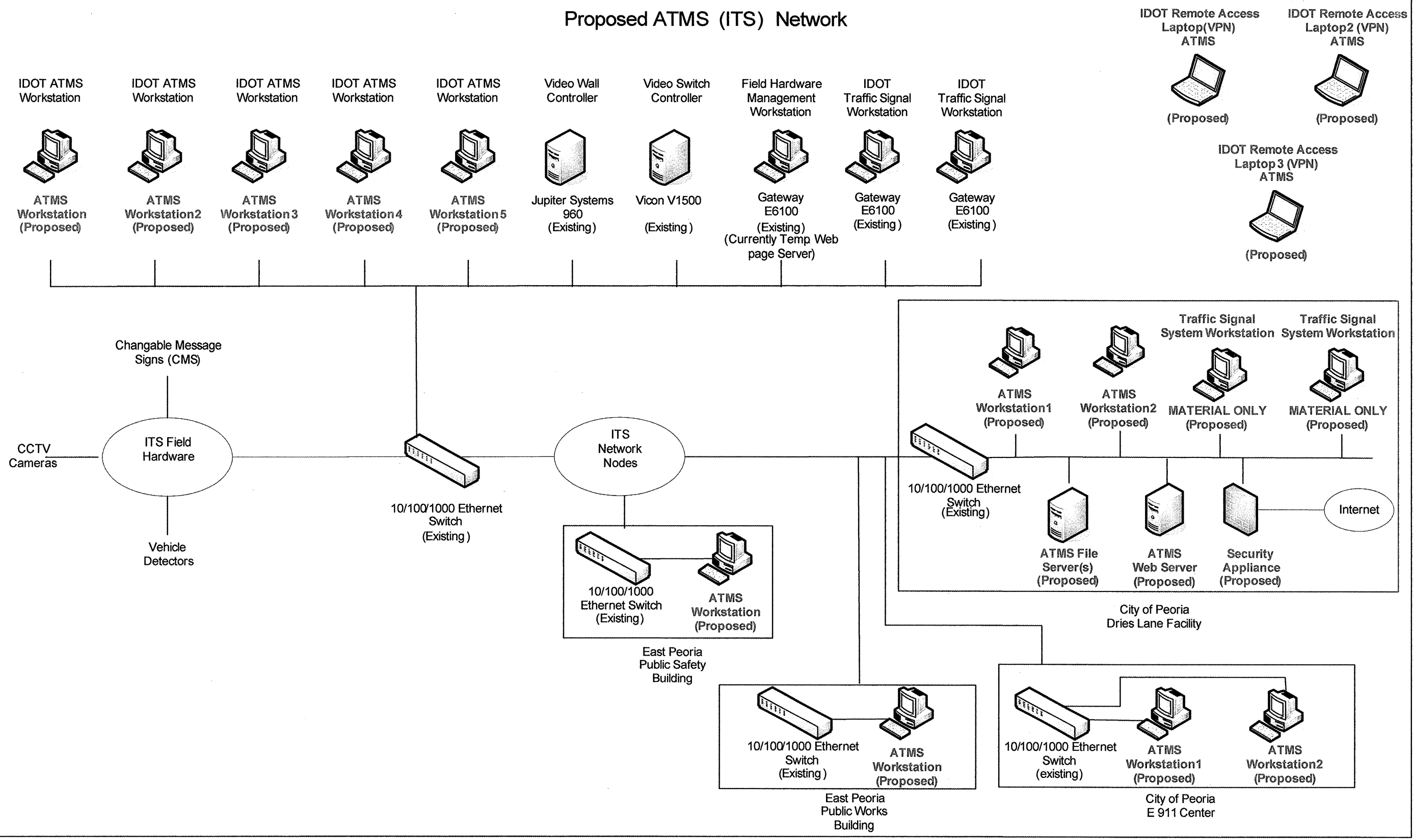

FILE NAME =	USER NAME = howlader	DESIGNED -	REVISED -	<b>STATE OF ILLINOIS DEPARTMENT OF TRANSPORTATION</b>	<b>PROPOSED ITS NETWORK SCHEMATIC</b>	F.A.I. RTE.	SECTION	COUNTY	TOTAL SHEETS	SHEET NO.	
PA-RFP 8-3-08-68273 - ATMS Software Pla	hsadgn	DRAWN -	REVISED -			74	D4 I-74 ITS SYSTEM-2	Peoria/Tazewell	20	20	
	PLOT SCALE = 5/1652 ' / IN.	CHECKED -	REVISED -			CONTRACT NO. 68273					
	PLOT DATE = 11/7/2008	DATE -	REVISED -			ILLINOIS FED. AID PROJECT					