

GROUNDING POINT DETAIL
N.T.S.

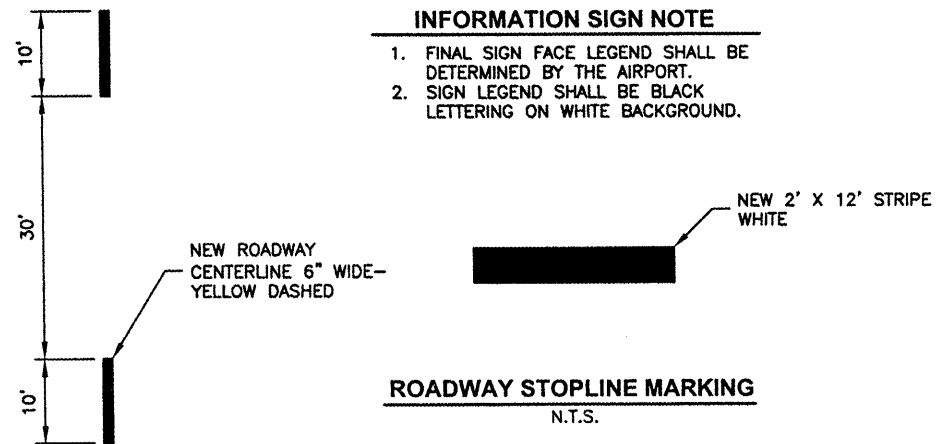

INFORMATION SIGN NOTE

1. FINAL SIGN FACE LEGEND SHALL BE DETERMINED BY THE AIRPORT.
2. SIGN LEGEND SHALL BE BLACK LETTERING ON WHITE BACKGROUND.

ROADWAY STOPLINE MARKING
N.T.S.

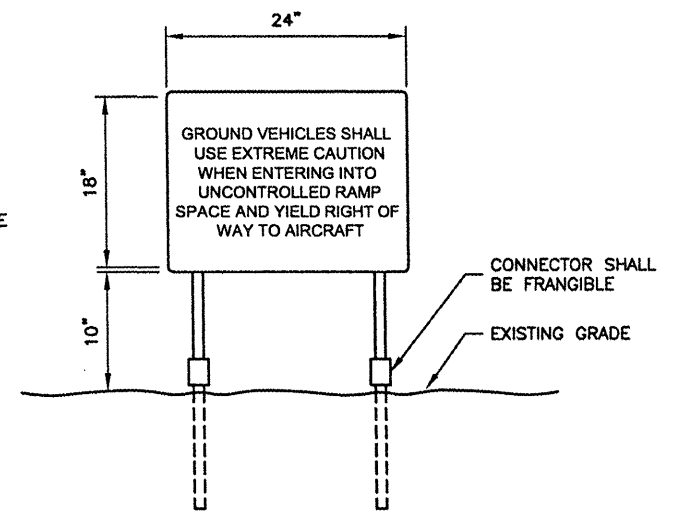

INFORMATION SIGN LEGEND
N.T.S.

CA008

REVISIONS		
NUMBER	BY	DATE

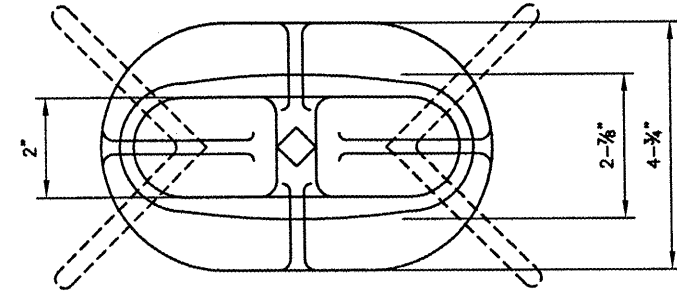
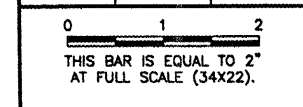

PLAN

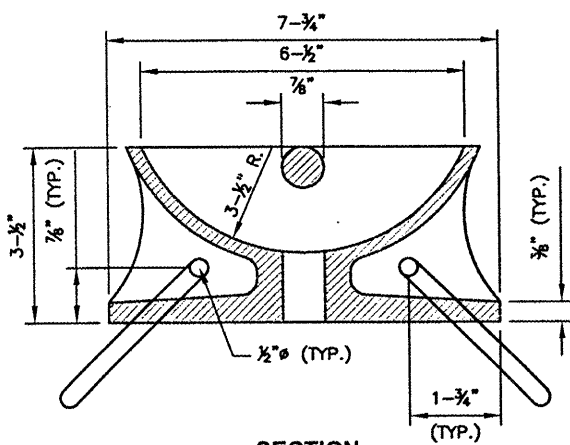

SECTION

NOTES:

1. MOORING CASTINGS SHALL BE NEENAH SEMI-STEEL AIRPORT MOORING EYE CATALOG NO. R3490 OR APPROVED EQUIVALENT.
2. ANCHOR RODS SHALL BE #3 DEFORMED REBAR, 15" LONG AND SHALL BE BENT DOWNWARD AT 45°. TWO ANCHOR BARS PER MOORING EYE ARE REQUIRED.
3. MOORING EYES SHALL BE INSTALLED AFTER THE PAVEMENT IS PLACED BY CORING THROUGH NEW PAVEMENT.

MOORING EYE DETAIL
N.T.S.

ROADWAY CENTERLINE - DASHED
N.T.S.

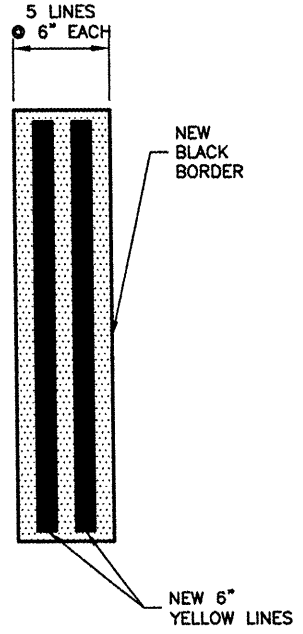
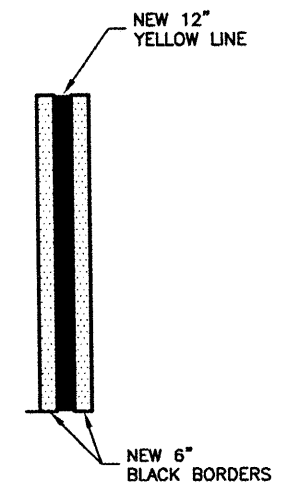

TAXIWAY CENTERLINE CONTINUOUS
N.T.S.

TAXIWAY EDGE MARKING CONTINUOUS
N.T.S.

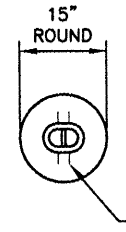

PLAN

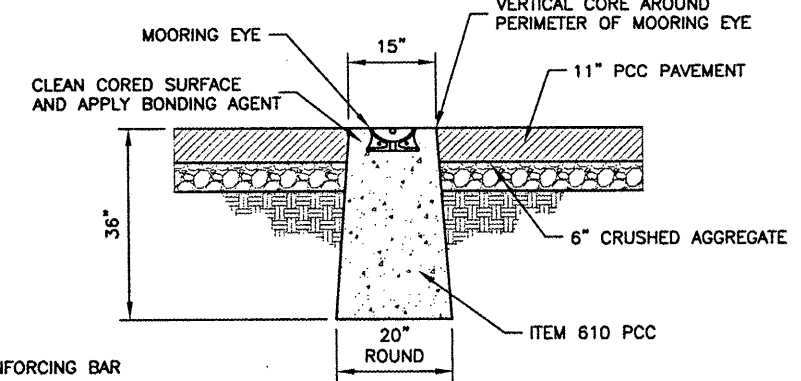

MOORING EYE IN PAVEMENT DETAIL
N.T.S.

NOTE: THE MOORING EYE SHALL BE INSTALLED AFTER PAVING OPERATIONS ARE COMPLETE.

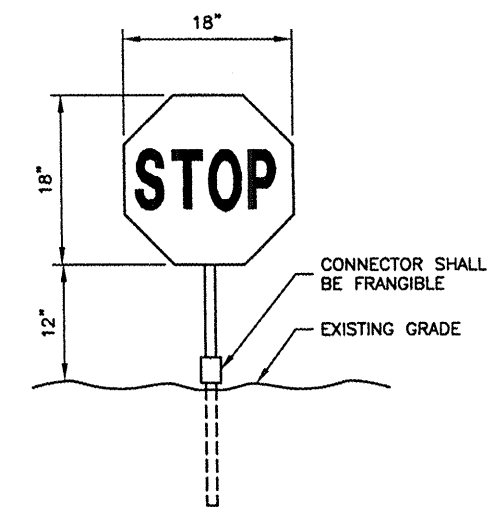

STOP SIGN DETAIL
N.T.S.

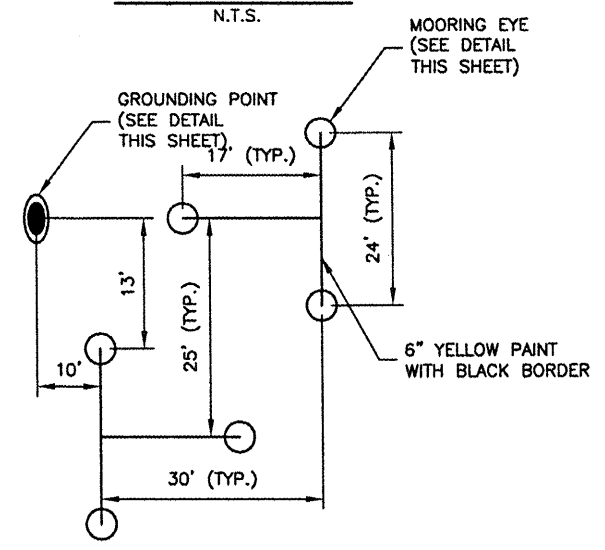

TIEDOWN DETAIL
N.T.S.



SPRINGFIELD AIRPORT AUTHORITY
 ABRAHAM LINCOLN CAPITAL AIRPORT
 SPRINGFIELD, ILLINOIS

RECONSTRUCT AND EXPAND THE SOUTHEAST RAMP
 MARKING & MISCELLANEOUS DETAILS

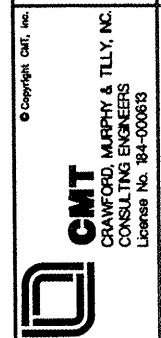

DESIGN BY:	RLV/KLB
DRAWN BY:	CMT
CHECKED BY:	RLV
APPROVED BY:	RLV
DATE:	JANUARY 27, 2009
JOB No:	08035-08
IL PROJ. NO.	SPI-3885
AIP PROJ. NO.	3-17-0096-XX
SHEET	28 OF 40 SHEETS