

RETURN WITH BID

LETTING DATE March 6, 2009

ITEM NUMBER 9A

Proposal Submitted By

Name _____

Address _____

City/State _____

9 Digit Zip Code _____

Telephone Number _____

FEIN Number _____

FAX Number _____

E-Mail Address _____

BIDDERS NEED NOT RETURN THE ENTIRE PROPOSAL
 (See instructions inside front cover)

NOTICE TO PROSPECTIVE BIDDERS

This proposal can be used for bidding purposes by only those companies that request and receive written AUTHORIZATION TO BID from IDOT's Central Bureau of Construction.
 (SEE INSTRUCTIONS ON THE INSIDE OF COVER)

PROPOSAL COVER SHEET



Illinois Department of Transportation
DIVISION OF AERONAUTICS

AIRPORT Greater Kankakee

MUNICIPAL DESIGNATION Kankakee

COUNTY DESIGNATION Kankakee

ILLINOIS PROJECT NO. IKK-3661

FEDERAL PROJECT NO. 3-17-0057-B13

FAA rules prohibit the use of escalation clauses for materials. Therefore, the Division of Aeronautics cannot offer a bituminous material cost adjustment provision for projects utilizing federal funds.

PLEASE MARK THE APPROPRIATE BOX BELOW:

- A Bid Bond is included.
- A Cashier's Check or a Certified Check is included.

INSTRUCTIONS

ABOUT IDOT PROPOSALS: All proposals issued by IDOT are potential bidding proposals. Each proposal contains all Certifications and Affidavits, a Proposal Signature Sheet and a Proposal Bid Bond required for Prime Contractors to submit a bid after written **Authorization to Bid** has been issued by IDOT’s Central Bureau of Construction.

HOW MANY PROPOSALS SHOULD PROSPECTIVE BIDDERS REQUEST?: Prospective bidders should, prior to submitting their initial request for plans and proposals, determine their needs and request the total number of plans and proposals needed for each item requested. There will be a nonrefundable charge of \$15 for each set of plans and specifications issued.

WHO CAN BID?: Bids will be accepted from only those companies that request and receive written **Authorization to Bid** from IDOT’s Central Bureau of Construction.

WHAT CONSTITUTES WRITTEN AUTHORIZATION TO BID?: When a prospective prime bidder submits a “Request for Proposal Forms and Plans” he/she must indicate at that time which items are being requested For Bidding purposes. Only those items requested For Bidding will be analyzed. After the request has been analyzed, the bidder will be issued a **Proposal Denial and/or Authorization Form**, approved by the Central Bureau of Construction, that indicates which items have been approved For Bidding. If **Authorization to Bid** cannot be approved, the **Proposal Denial and/or Authorization Form** will indicate the reason for denial. If a contractor has requested to bid but has not received a **Proposal Denial and/or Authorization Form**, they should contact the Central Bureau of Construction in advance of the letting date.

WHAT MUST BE INCLUDED WHEN BIDS ARE SUBMITTED?: Bidders need not return the entire proposal when bids are submitted. That portion of the proposal that must be returned includes the following:

1. All documents from the Proposal Cover Sheet through the Proposal Bid Bond
2. Other special documentation and/or information that may be required by the contract special provisions

All proposal documents, including Proposal Guaranty Checks or Proposal Bid Bonds, should be stapled together to prevent loss when bids are processed by IDOT personnel.

ABOUT SUBMITTING BIDS: It is recommended that bidders deliver bids in person to insure they arrive at the proper location prior to the time specified for the receipt of bids. Any bid received at the place of letting after the time specified will not be accepted.

WHO SHOULD BE CALLED IF ASSISTANCE IS NEEDED?

Questions Regarding	Call
Prequalification and/or Authorization to Bid	217/782-3413
Preparation and submittal of bids	217/782-7806
Mailing of plans and proposals	217/782-7806



PROPOSAL

1. Proposal of _____

for the improvement officially known as:

- (a) Greater Kankakee Airport
- (b) The proposed improvement shown in detail on the plans issued by the Department schedule and detail sheets included herein, includes, in general, the following described work:

Construct Southeast Quadrant Fire Protection

TO THE DEPARTMENT OF TRANSPORTATION

2. The plans for the proposed work are those issued by the Department of Transportation to cover the work described above.

The specifications are those prepared by the Department of Transportation, Division of Aeronautics and designated as "Standard Specifications for Construction of Airports," adopted January, 1985, the "Supplemental Specifications and Recurring Special Provisions," adopted July 1, 2004 and the "Special Provisions" thereto, adopted and in effect on the date of invitation for bids.

3. **COMPLETION TIME/LIQUIDATED DAMAGES.** It being understood and agreed that the completion within the time limit is an essential part of the contract, the bidder agrees to complete the work within 31 calendar days, unless additional time is granted by the Engineer in accordance with the provisions of the specifications. In case of failure to complete the work on or before the time named herein, or within such extra time as may have been allowed by extensions, the bidder agrees that the Department of Transportation shall withhold from such sum as may be due him/her under the terms of this contract, the costs, as set forth below, which costs shall be considered and treated not as a penalty but as damages due to the State from the bidder by reason of the failure of the bidder to complete the work within the time specified in the contract. The following Schedule of Deductions supersedes the table given in Section 60-09 of the Division's Standard Specifications for Construction of Airports.

Schedule of Deductions for Each Day of Overrun in Contract Time

<u>Original Contract Amount</u>		<u>Daily Charge</u>
<u>From More Than</u>	<u>To and Including</u>	<u>Calendar Day</u>
\$ 0	\$ 25,000	\$ 300
25,000	100,000	375
100,000	500,000	550
500,000	1,000,000	725
1,000,000	2,000,000	900
2,000,000	3,000,000	1,100
3,000,000	5,000,000	1,300
5,000,000	7,500,000	1,450
7,500,000	10,000,000	1,650

A daily charge shall be made for every day shown on the calendar beyond the specified contract time in calendar days.

RETURN WITH BID

4. **ASSURANCE OF EXAMINATION AND INSPECTION/WAIVER.** The undersigned further declares that he/she has carefully examined the proposal, plans, specifications, supplemental and applicable recurring special provisions, form of contract and contract bonds, and special provisions, and that he/she has inspected in detail the site of the proposed work, and that he/she has familiarized themselves with all of the local conditions affecting the contract and the detailed requirements of construction, and understands that in making this proposal he/she waives all right to plead any misunderstanding regarding the same.

5. **EXECUTION OF CONTRACT AND CONTRACT BONDS.** The undersigned further agrees to execute a contract for this work and present the same to the department within fifteen (15) days after the contract has been mailed to him/her. The undersigned further agrees that he/she and his/her surety will execute and present within fifteen (15) days after the contract has been mailed to him/her contract bonds satisfactory to and in the form prescribed by the Department of Transportation, in the penal sum of the full amount of the contract, guaranteeing the faithful performance of the work in accordance with the terms of the contract and guaranteeing payment in full all bills and accounts for materials and labor used in the construction of the work.

6. **PROPOSAL GUARANTY.** Accompanying this proposal is either a bid bond on the department form, executed by a corporate surety company satisfactory to the department, or a proposal guaranty check consisting of a bank cashier's check or a properly certified check for not less than 5 per cent of the amount bid or for the amount specified in the following schedule:

<u>Amount of Bid</u>	<u>Proposal Guaranty</u>	<u>Amount of Bid</u>	<u>Proposal Guaranty</u>
Up to \$5,000	\$5,000.....\$150	\$2,000,000 to \$3,000,000	\$3,000,000..... \$100,000
\$5,000 to \$10,000	\$10,000.....\$300	\$3,000,000 to \$5,000,000	\$5,000,000..... \$150,000
\$10,000 to \$50,000	\$50,000.....\$1,000	\$5,000,000 to \$7,500,000	\$7,500,000..... \$250,000
\$50,000 to \$100,000	\$100,000.....\$3,000	\$7,500,000 to \$10,000,000	\$10,000,000..... \$400,000
\$100,000 to \$150,000	\$150,000.....\$5,000	\$10,000,000 to \$15,000,000	\$15,000,000..... \$500,000
\$150,000 to \$250,000	\$250,000.....\$7,500	\$15,000,000 to \$20,000,000	\$20,000,000..... \$600,000
\$250,000 to \$500,000	\$500,000.....\$12,500	\$20,000,000 to \$25,000,000	\$25,000,000.....\$700,000
\$500,000 to \$1,000,000	\$1,000,000.....\$25,000	\$25,000,000 to \$30,000,000	\$30,000,000..... \$800,000
\$1,000,000 to \$1,500,000	\$1,500,000.....\$50,000	\$30,000,000 to \$35,000,000	\$35,000,000..... \$900,000
\$1,500,000 to \$2,000,000	\$2,000,000.....\$75,000	over \$35,000,000	\$35,000,000..... \$1,000,000

Bank cashier's checks or properly certified checks accompanying proposals shall be made payable to the Treasurer, State of Illinois, when the state is awarding authority; the county treasurer, when a county is the awarding authority; or the city, village, or town treasurer, when a city, village, or town is the awarding authority.

If a combination bid is submitted, the proposal guaranties which accompany the individual proposals making up the combination will be considered as also covering the combination bid.

The amount of the proposal guaranty check is _____ \$(). If this proposal is accepted and the undersigned shall fail to execute contract bonds as required herein, it is hereby agreed that the amount of the proposal guaranty shall become the property of the State of Illinois, and shall be considered as payment of damages due to delay and other causes suffered by the State because of the failure to execute said contract and contract bonds; otherwise, the bid bond shall become void or the proposal guaranty check shall be returned to the undersigned.

RETURN WITH BID

(e) The plans and Special Provisions for each separate contract shall be construed separately for all requirements, except as described in paragraphs (a) through (d) listed above.

When a combination bid is submitted, the schedule below must be completed in each proposal comprising the combination.

If alternate bids are submitted for one or more of the sections comprising the combination, a combination bid must be submitted for each alternate.

Schedule of Combination Bids

Combination No.	Sections Included in Combination	Combination Bid	
		Dollars	Cents

8. **SCHEDULE OF PRICES.** The undersigned submits herewith his/her schedule of prices covering the work to be performed under this contract; he/she understands that he/she must show in the schedule the unit prices (with no more than two decimal places, i.e. \$25.35, not \$25.348) for which he/she proposes to perform each item of work, that the extensions must be made by him/her, and that if not so done his/her proposal may be rejected as irregular.

The undersigned further agrees that the unit prices submitted herewith are for the purpose of obtaining a gross sum, and for use in computing the value of additions and deductions; that if there is a discrepancy between the gross sum bid and that resulting from the summation of the quantities multiplied by their respective unit prices, the latter shall govern.

STATE JOB #- - - -

ILLINOIS DEPARTMENT OF TRANSPORTATION
 SCHEDULE OF PRICES
 CONTRACT NUMBER - KA037

ECMS002 DTGECM03 ECMR003 PAGE 1
 RUN DATE - 01/21/09
 RUN TIME - 202442

COUNTY NAME	CODE	DIST	AIRPORT NAME	FED PROJECT	ILL PROJECT
KANKAKEE	091	03	GREATER KANKAKEE	3-17-0057-B13	IK-K -3661

ITEM NUMBER	PAY ITEM DESCRIPTION	UNIT OF MEASURE	QUANTITY	UNIT PRICE		TOTAL PRICE	
				DOLLARS	CENTS	DOLLARS	CTS
AR156531	EROSION CONTROL BLANKET	S.Y.	2,650.000	X	=		
AR401910	REMOVE & REPLACE BIT. PAVEMENT	S.Y.	120.000	X	=		
AR701512	12" RCP, CLASS IV	L.F.	16.000	X	=		
AR701830	TRENCH BACKFILL	C.Y.	150.000	X	=		
AR701900	REMOVE PIPE	L.F.	36.000	X	=		
AR760504	4" DUCTILE IRON WATER MAIN	L.F.	100.000	X	=		
AR760508	8" DUCTILE IRON WATER MAIN	L.F.	1,190.000	X	=		
AR760800	FIRE HYDRANT	EACH	3.000	X	=		
AR760830	WATER VALVE	EACH	5.000	X	=		
AR760850	WATER VAULT	EACH	1.000	X	=		
AR770506	6" SANITARY SEWER	L.F.	40.000	X	=		
AR800019	FRESH WATER WELL ABANDONMENT	EACH	1.000	X	=		
AR800054	REMOVE AND REPLACE FENCE	L.F.	20.000	X	=		
AR901510	SEEDING	ACRE	0.600	X	=		
AR905530	TOPSOILING	S.Y.	2,650.000	X	=		

GREATER KANKAKEE
KANKAKEE

ILLINOIS DEPARTMENT OF TRANSPORTATION
SCHEDULE OF PRICES
CONTRACT NUMBER - KA037

ECMS002 DTGECM03 ECMR003 PAGE 2
RUN DATE - 01/21/09
RUN TIME - 202442

TOTAL \$

--	--

NOTE:

1. EACH PAY ITEM SHOULD HAVE A UNIT PRICE AND A TOTAL PRICE.
2. THE UNIT PRICE SHALL GOVERN IF NO TOTAL PRICE IS SHOWN OR IF THERE IS A DISCREPANCY BETWEEN THE PRODUCT OF THE UNIT PRICE MULTIPLIED BY THE QUANTITY.
3. IF A UNIT PRICE IS OMITTED, THE TOTAL PRICE WILL BE DIVIDED BY THE QUANTITY IN ORDER TO ESTABLISH A UNIT PRICE.
4. A BID MAY BE DECLARED UNACCEPTABLE IF NEITHER A UNIT PRICE NOR A TOTAL PRICE IS SHOWN.

RETURN WITH BID

THE PRECEDING SCHEDULE OF PRICES MUST BE

COMPLETED AND RETURNED.

RETURN WITH BID

**STATE REQUIRED ETHICAL
STANDARDS GOVERNING CONTRACT
PROCUREMENT: ASSURANCES, CERTIFICATIONS
AND DISCLOSURES**

I. GENERAL

A. Article 50 of the Illinois Procurement Code establishes the duty of all State chief procurement officers, State purchasing officers, and their designees to maximize the value of the expenditure of public moneys in procuring goods, services, and contracts for the State of Illinois and to act in a manner that maintains the integrity and public trust of State government. In discharging this duty, they are charged by law to use all available information, reasonable efforts, and reasonable actions to protect, safeguard, and maintain the procurement process of the State of Illinois.

B. In order to comply with the provisions of Article 50 and to carry out the duty established therein, all bidders are to adhere to ethical standards established for the procurement process, and to make such assurances, disclosures and certifications required by law. By execution of the Proposal Signature Sheet, the bidder indicates that each of the mandated assurances has been read and understood, that each certification is made and understood, and that each disclosure requirement has been understood and completed.

C. In addition to all other remedies provided by law, failure to comply with any assurance, failure to make any disclosure or the making of a false certification shall be grounds for termination of the contract and the suspension or debarment of the bidder.

II. ASSURANCES

A. The assurances hereinafter made by the bidder are each a material representation of fact upon which reliance is placed should the Department enter into the contract with the bidder. The Department may terminate the contract if it is later determined that the bidder rendered a false or erroneous assurance, and the surety providing the performance bond shall be responsible for the completion of the contract.

B. Felons

1. The Illinois Procurement Code provides:

Section 50-10. Felons. Unless otherwise provided, no person or business convicted of a felony shall do business with the State of Illinois or any state agency from the date of conviction until 5 years after the date of completion of the sentence for that felony, unless no person held responsible by a prosecutorial office for the facts upon which the conviction was based continues to have any involvement with the business.

2. The bidder assures the Department that the award and execution of the contract would not cause a violation of Section 50-10.

C. Conflicts of Interest

1. The Illinois Procurement Code provides in pertinent part:

Section 50-13. Conflicts of Interest.

(a) Prohibition. It is unlawful for any person holding an elective office in this State, holding a seat in the General Assembly, or appointed to or employed in any of the offices or agencies of state government and who receives compensation for such employment in excess of 60% of the salary of the Governor of the State of Illinois, or who is an officer or employee of the Capital Development Board or the Illinois Toll Highway Authority, or who is the spouse or minor child of any such person to have or acquire any contract, or any direct pecuniary interest in any contract therein, whether for stationery, printing, paper, or any services, materials, or supplies, that will be wholly or partially satisfied by the payment of funds appropriated by the General Assembly of the State of Illinois or in any contract of the Capital Development Board or the Illinois Toll Highway authority.

(b) Interests. It is unlawful for any firm, partnership, association or corporation, in which any person listed in subsection (a) is entitled to receive (i) more than 7 1/2% of the total distributable income or (ii) an amount in excess of the salary of the Governor, to have or acquire any such contract or direct pecuniary interest therein.

(c) Combined interests. It is unlawful for any firm, partnership, association, or corporation, in which any person listed in subsection (a) together with his or her spouse or minor children is entitled to receive (i) more than 15%, in the aggregate, of the total distributable income or (ii) an amount in excess of 2 times the salary of the Governor, to have or acquire any such contract or direct pecuniary interest therein.

(d) Securities. Nothing in this Section invalidates the provisions of any bond or other security previously offered or to be offered for sale or sold by or for the State of Illinois.

(e) Prior interests. This Section does not affect the validity of any contract made between the State and an officer or employee of the State or member of the General Assembly, his or her spouse, minor child or any combination of those persons if that contract was in existence before his or her election or employment as an officer, member, or employee. The contract is voidable, however, if it cannot be completed within 365 days after the officer, member, or employee takes office or is employed.

The current salary of the Governor is \$145,877.00. Sixty percent of the salary is \$87,526.20.

2. The bidder assures the Department that the award and execution of the contract would not cause a violation of Section 50-13, or that an effective exemption has been issued by the Board of Ethics to any individual subject to the Section 50-13 prohibitions pursuant to the provisions of Section 50-20 of the Code and Executive Order Number 3 (1998). Information concerning the exemption process is available from the Department upon request.

D. Negotiations

1. The Illinois Procurement Code provides in pertinent part:

Section 50-15. Negotiations.

(a) It is unlawful for any person employed in or on a continual contractual relationship with any of the offices or agencies of State government to participate in contract negotiations on behalf of that office or agency with any firm, partnership, association, or corporation with whom that person has a contract for future employment or is negotiating concerning possible future employment.

2. The bidder assures the Department that the award and execution of the contract would not cause a violation of Section 50-15, and that the bidder has no knowledge of any facts relevant to the kinds of acts prohibited therein.

RETURN WITH BID

E. Inducements

1. The Illinois Procurement Code provides:

Section 50-25. Inducement. Any person who offers or pays any money or other valuable thing to any person to induce him or her not to bid for a State contract or as recompense for not having bid on a State contract is guilty of a Class 4 felony. Any person who accepts any money or other valuable thing for not bidding for a State contract or who withholds a bid in consideration of the promise for the payment of money or other valuable thing is guilty of a Class 4 felony.

2. The bidder assures the Department that the award and execution of the contract would not cause a violation of Section 50-25, and that the bidder has no knowledge of any facts relevant to the kinds of acts prohibited therein.

F. Revolving Door Prohibition

1. The Illinois Procurement Code provides:

Section 50-30. Revolving door prohibition. Chief procurement officers, associate procurement officers, State purchasing officers, their designees whose principal duties are directly related to State procurement, and executive officers confirmed by the Senate are expressly prohibited for a period of 2 years after terminating an affected position from engaging in any procurement activity relating to the State agency most recently employing them in an affected position for a period of at least 6 months. The prohibition includes, but is not limited to: lobbying the procurement process; specifying; bidding; proposing bid, proposal, or contract documents; on their own behalf or on behalf of any firm, partnership, association, or corporation. This Section applies only to persons who terminate an affected position on or after January 15, 1999.

2. The bidder assures the Department that the award and execution of the contract would not cause a violation of Section 50-30, and that the bidder has no knowledge of any facts relevant to the kinds of acts prohibited therein.

G. Reporting Anticompetitive Practices

1. The Illinois Procurement Code provides:

Section 50-40. Reporting anticompetitive practices. When, for any reason, any vendor, bidder, contractor, chief procurement officer, State purchasing officer, designee, elected official, or State employee suspects collusion or other anticompetitive practice among any bidders, offers, contractors, proposers, or employees of the State, a notice of the relevant facts shall be transmitted to the Attorney General and the chief procurement officer.

2. The bidder assures the Department that it has not failed to report any relevant facts concerning the practices addressed in Section 50-40 which may involve the contract for which the bid is submitted.

H. Confidentiality

1. The Illinois Procurement Code provides:

Section 50-45. Confidentiality. Any chief procurement officer, State purchasing officer, designee, or executive officer who willfully uses or allows the use of specifications, competitive bid documents, proprietary competitive information, proposals, contracts, or selection information to compromise the fairness or integrity of the procurement, bidding, or contract process shall be subject to immediate dismissal, regardless of the Personnel code, any contract, or any collective bargaining agreement, and may in addition be subject to criminal prosecution.

2. The bidder assures the Department that it has no knowledge of any fact relevant to the practices addressed in Section 50-45 which may involve the contract for which the bid is submitted.

RETURN WITH BID

I. Insider Information

1. The Illinois Procurement Act provides:

Section 50-50. Insider information. It is unlawful for any current or former elected or appointed State official or State employee to knowingly use confidential information available only by virtue of that office or employment for actual or anticipated gain for themselves or another person.

2. The bidder assures the Department that it has no knowledge of any facts relevant to the practices addressed in Section 50-50 which may involve the contract for which the bid is submitted.

III. CERTIFICATIONS

A. The certifications hereinafter made by the bidder are each a material representation of fact upon which reliance is placed should the Department enter into the contract with the bidder. The Department may terminate the contract if it is later determined that the bidder rendered a false or erroneous certification, and the surety providing the performance bond shall be responsible for completion of the contract.

B. Bribery

1. The Illinois Procurement Code provides:

Section 50-5. Bribery.

(a) Prohibition. No person or business shall be awarded a contract or subcontract under this Code who:

(1) has been convicted under the laws of Illinois or any other state of bribery or attempting to bribe an officer or employee of the State of Illinois or any other state in that officer's or employee's official capacity; or

(2) has made an admission of guilt of that conduct that is a matter of record but has not been prosecuted for that conduct.

(b) Businesses. No business shall be barred from contracting with any unit of State or local government as a result of a conviction under this Section of any employee or agent of the business if the employee or agent is no longer employed by the business and:

(1) the business has been finally adjudicated not guilty; or

(2) the business demonstrates to the governmental entity with which it seeks to contract, and that entity finds that the commission of the offense was not authorized, requested, commanded, or performed by a director, officer, or high managerial agent on behalf of the business as provided in paragraph (2) of subsection (a) of Section 5-4 of the Criminal Code of 1961.

(c) Conduct on behalf of business. For purposes of this Section, when an official, agent, or employee of a business committed the bribery or attempted bribery on behalf of the business and in accordance with the direction or authorization of a responsible official of the business, the business shall be chargeable with the conduct.

(d) Certification. Every bid submitted to and contract executed by the State shall contain a certification by the contractor that the contractor is not barred from being awarded a contract or subcontract under this Section. A contractor who makes a false statement, material to the certification, commits a Class 3 felony.

2. The bidder certifies that it is not barred from being awarded a contract under Section 50.5.

RETURN WITH BID

C. Educational Loan

1. Section 3 of the Educational Loan Default Act provides:

§ 3. No State agency shall contract with an individual for goods or services if that individual is in default, as defined in Section 2 of this Act, on an educational loan. Any contract used by any State agency shall include a statement certifying that the individual is not in default on an educational loan as provided in this Section.

2. The bidder, if an individual as opposed to a corporation, partnership or other form of business organization, certifies that the bidder is not in default on an educational loan as provided in Section 3 of the Act.

D. Bid-Rigging/Bid Rotating

1. Section 33E-11 of the Criminal Code of 1961 provides:

§ 33E-11. (a) Every bid submitted to and public contract executed pursuant to such bid by the State or a unit of local government shall contain a certification by the prime contractor that the prime contractor is not barred from contracting with any unit of State or local government as a result of a violation of either Section 33E-3 or 33E-4 of this Article. The State and units of local government shall provide the appropriate forms for such certification.

(b) A contractor who makes a false statement, material to the certification, commits a Class 3 felony.

A violation of Section 33E-3 would be represented by a conviction of the crime of bid-rigging which, in addition to Class 3 felony sentencing, provides that any person convicted of this offense or any similar offense of any state or the United States which contains the same elements as this offense shall be barred for 5 years from the date of conviction from contracting with any unit of State or local government. No corporation shall be barred from contracting with any unit of State or local government as a result of a conviction under this Section of any employee or agent of such corporation if the employee so convicted is no longer employed by the corporation and: (1) it has been finally adjudicated not guilty or (2) if it demonstrates to the governmental entity with which it seeks to contract and that entity finds that the commission of the offense was neither authorized, requested, commanded, nor performed by a director, officer or a high managerial agent in behalf of the corporation.

A violation of Section 33E-4 would be represented by a conviction of the crime of bid-rotating which, in addition to Class 2 felony sentencing, provides that any person convicted of this offense or any similar offense of any state or the United States which contains the same elements as this offense shall be permanently barred from contracting with any unit of State or local government. No corporation shall be barred from contracting with any unit of State or local government as a result of a conviction under this Section of any employee or agent of such corporation if the employee so convicted is no longer employed by the corporation and: (1) it has been finally adjudicated not guilty or (2) if it demonstrates to the governmental entity with which it seeks to contract and that entity finds that the commission of the offense was neither authorized, requested, commanded, nor performed by a director, officer or a high managerial agent in behalf of the corporation.

2. The bidder certifies that it is not barred from contracting with the Department by reason of a violation of either Section 33E-3 or Section 33E-4.

E. International Anti-Boycott

1. Section 5 of the International Anti-Boycott Certification Act provides:

§ 5. State contracts. Every contract entered into by the State of Illinois for the manufacture, furnishing, or purchasing of supplies, material, or equipment or for the furnishing of work, labor, or services, in an amount exceeding the threshold for small purchases according to the purchasing laws of this State or \$10,000.00, whichever is less, shall contain certification, as a material condition of the contract, by which the contractor agrees that neither the contractor nor any substantially-owned affiliated company is participating or shall participate in an international boycott in violation of the provisions of the U.S. Export Administration Act of 1979 or the regulations of the U.S. Department of Commerce promulgated under that Act.

2. The bidder makes the certification set forth in Section 5 of the Act.

RETURN WITH BID

F. Drug Free Workplace

1. The Illinois “Drug Free Workplace Act” applies to this contract and it is necessary to comply with the provisions of the “Act” if the contractor is a corporation, partnership, or other entity (including a sole proprietorship) which has 25 or more employees.

2. The bidder certifies that if awarded a contract in excess of \$5,000 it will provide a drug free workplace by:

(a) Publishing a statement notifying employees that the unlawful manufacture, distribution, dispensation, possession or use of a controlled substance, including cannabis, is prohibited in the contractor’s workplace; specifying the actions that will be taken against employees for violations of such prohibition; and notifying the employee that, as a condition of employment on such contract, the employee shall abide by the terms of the statement, and notify the employer of any criminal drug statute conviction for a violation occurring in the workplace no later than five (5) days after such conviction.

(b) Establishing a drug free awareness program to inform employees about the dangers of drug abuse in the workplace; the contractor’s policy of maintaining a drug free workplace; any available drug counseling, rehabilitation, and employee assistance programs; and the penalties that may be imposed upon employees for drug violations.

(c) Providing a copy of the statement required by subparagraph (1) to each employee engaged in the performance of the contract and to post the statement in a prominent place in the workplace.

(d) Notifying the Department within ten (10) days after receiving notice from an employee or otherwise receiving actual notice of the conviction of an employee for a violation of any criminal drug statute occurring in the workplace.

(e) Imposing or requiring, within 30 days after receiving notice from an employee of a conviction or actual notice of such a conviction, an appropriate personnel action, up to and including termination, or the satisfactory participation in a drug abuse assistance or rehabilitation program approved by a federal, state or local health, law enforcement or other appropriate agency.

(f) Assisting employees in selecting a course of action in the event drug counseling, treatment, and rehabilitation is required and indicating that a trained referral team is in place.

(g) Making a good faith effort to continue to maintain a drug free workplace through implementation of the actions and efforts stated in this certification.

G. Debt Delinquency

1. The Illinois Procurement Code provides:

Section 50-11 and 50-12. Debt Delinquency.

The contractor or bidder certifies that it, or any affiliate, is not barred from being awarded a contract under 30 ILCS 500. Section 50-11 prohibits a person from entering into a contract with a State agency if it knows or should know that it, or any affiliate, is delinquent in the payment of any debt to the State as defined by the Debt Collection Board. Section 50-12 prohibits a person from entering into a contract with a State agency if it, or any affiliate, has failed to collect and remit Illinois Use Tax on all sales of tangible personal property into the State of Illinois in accordance with the provisions of the Illinois Use Tax Act. The contractor further acknowledges that the contracting State agency may declare the contract void if this certification is false or if the contractor, or any affiliate, is determined to be delinquent in the payment of any debt to the State during the term of the contract.

RETURN WITH BID

H. Sarbanes-Oxley Act of 2002

1. The Illinois Procurement Code provides:

Section 50-60(c).

The contractor certifies in accordance with 30 ILCS 500/50-10.5 that no officer, director, partner or other managerial agent of the contracting business has been convicted of a felony under the Sarbanes-Oxley Act of 2002 or a Class 3 or Class 2 felony under the Illinois Securities Law of 1953 for a period of five years prior to the date of the bid or contract. The contractor acknowledges that the contracting agency shall declare the contract void if this certification is false.

I. Addenda

The contractor or bidder certifies that all relevant addenda have been incorporated in to this contract. Failure to do so may cause the bid to be declared unacceptable.

J. Section 42 of the Environmental Protection Act

The contractor certifies in accordance with 30 ILCS 500/50-12 that the bidder or contractor is not barred from being awarded a contract under this Section which prohibits the bidding on or entering into contracts with the State of Illinois or a State agency by a person or business found by a court or the Pollution Control Board to have committed a willful or knowing violation of Section 42 of the Environmental Protection Act for a period of five years from the date of the order. The contractor acknowledges that the contracting agency may declare the contract void if this certification is false.

K. Apprenticeship and Training Certification (Does not apply to federal aid projects)

In accordance with the provisions of Section 30-22 (6) of the Illinois Procurement Code, the bidder certifies that it is a participant, either as an individual or as part of a group program, in the approved apprenticeship and training programs applicable to each type of work or craft that the bidder will perform with its own forces. The bidder further certifies for work that will be performed by subcontract that each of its subcontractors submitted for approval either (a) is, at the time of such bid, participating in an approved, applicable apprenticeship and training program; or (b) will, prior to commencement of performance of work pursuant to this contract, begin participation in an approved apprenticeship and training program applicable to the work of the subcontract. The Department, at any time before or after award, may require the production of a copy of each applicable Certificate of Registration issued by the United States Department of Labor evidencing such participation by the contractor and any or all of its subcontractors. Applicable apprenticeship and training programs are those that have been approved and registered with the United States Department of Labor. The bidder shall list in the space below, the official name of the program sponsor holding the Certificate of Registration for all of the types of work or crafts in which the bidder is a participant and that will be performed with the bidder's forces. Types of work or craft work that will be subcontracted shall be included and listed as subcontracted work. The list shall also indicate any type of work or craft job category that does not have an applicable apprenticeship or training program. **The bidder is responsible for making a complete report and shall make certain that each type of work or craft job category that will be utilized on the project as reported on the Construction Employee Workforce Projection (Form BC-1256) and returned with the bid is accounted for and listed.**

N/A (Federal)

The requirements of this certification and disclosure are a material part of the contract, and the contractor shall require this certification provision to be included in all approved subcontracts. In order to fulfill this requirement, it shall not be necessary that an applicable program sponsor be currently taking or that it will take applications for apprenticeship, training or employment during the performance of the work of this contract.

RETURN WITH BID

L. Executive Order Number 1 (2007) Regarding Lobbying on Government Procurements

The bidder hereby warrants and certifies that they have complied and will comply with the requirements set forth in this Order. The requirements of this warrant and certification are a material part of the contract, and the contractor shall require this warrant and certification provision to be included in all approved subcontracts.

M. Disclosure of Business Operations in Iran

Public Act 95-0616 provides that each bid, offer, or proposal submitted for a State contract shall include a disclosure of whether or not the Company acting as the bidder, offeror, or proposing entity, or any of its corporate parents or subsidiaries, within the 24 months before submission of the bid, offer, or proposal had business operations that involved contracts with or provision of supplies or services to the Government of Iran, companies in which the Government of Iran has any direct or indirect equity share, consortiums or projects commissioned by the Government of Iran, or companies involved in consortiums or projects commissioned by the Government of Iran and either of the following conditions apply:

(1) More than 10% of the Company's revenues produced in or assets located in Iran involve oil-related activities or mineral-extraction activities; less than 75% of the Company's revenues produced in or assets located in Iran involve contracts with or provision of oil-related or mineral-extraction products or services to the Government of Iran or a project or consortium created exclusively by that government; and the Company has failed to take substantial action.

(2) The Company has, on or after August 5, 1996, made an investment of \$20 million or more, or any combination of investments of at least \$10 million each that in the aggregate equals or exceeds \$20 million in any 12-month period, which directly or significantly contributes to the enhancement of Iran's ability to develop petroleum resources of Iran.

The terms "Business operations", "Company", "Mineral-extraction activities", "Oil-related activities", "Petroleum resources", and "Substantial action" are all defined in the Act.

Failure to make the disclosure required by the Act shall cause the bid, offer or proposal to be considered not responsive. The disclosure will be considered when evaluating the bid, offer, or proposal or awarding the contract. The name of each Company disclosed as doing business or having done business in Iran will be provided to the State Comptroller.

Check the appropriate statement:

Company has no business operations in Iran to disclose.

Company has business operations in Iran as disclosed in the attached document.

RETURN WITH BID

N. PA 95-0635 SUBSTANCE ABUSE PREVENTION PROGRAM (SAPP)

Effective January 1, 2008

This Public Act requires that all contractors and subcontractors have an SAPP, meeting certain requirements, in place **before** starting work.

The contractor must submit their correctly completed SAPP Certification (Form BC 261) prior to issuance of the Notice-to-Proceed.

The requirements of this Public Act are a material part of the contract, and the contractor shall require this provision to be included in all approved subcontracts. The contractor shall submit the correctly completed SAPP Certification Form BC 261 for each subcontractor with the Request for Approval of Subcontractor (Form AER 260-A) prior to issuance of the Notice-to-Proceed.

All SAPPs and Requests for Approval of Subcontractor are to be submitted to:

Department of Transportation
Division of Aeronautics
Attn: Chief Engineer
1 Langhorne Bond Drive
Capital Airport
Springfield, IL 62707-8415.

Telephone number (217) 785-8514

Telefax number (217) 785-4533

O. PA 95-0971

Effective February 1, 2009

This Public Act amends the Illinois State Procurement Code (30 ILCS 500) by adding Sections 20-160 and 50-37.

Section 20-160 (b) states “Every bid submitted to and every contract executed by the State on or after the effective date of this amendatory Act of the 95th General Assembly shall contain (1) a certification by the bidder or contractor that either (i) the bidder or contractor is not required to register as a business entity with the State Board of Elections pursuant to this Section or (ii) the bidder or contractor has registered as a business entity with the State Board of Elections and acknowledges a continuing duty to update the registration and (2) a statement that the contract is voidable under Section 50-60 for the bidder’s or contractor’s failure to comply with this Section.”

Check the appropriate statement:

The contractor certifies that they are not required to register as a business entity with the State Board of Elections pursuant to the Procurement Code (30 ILCS 500/20-160). Further, the contractor acknowledges that all contracts between State agencies and a business entity that do not comply with this Section shall be voidable under Section 50-60 of the Procurement Code (30 ILCS 500/50-60).

The contractor certifies that they have registered as a business entity with the State Board of Elections and acknowledges a continuing duty to update the registration pursuant to the Procurement Code (30 ILCS 500/20-160). Further, the contractor acknowledges that all contracts between State agencies and a business entity that do not comply with this Section shall be voidable under Section 50-60 of the Procurement Code (30 ILCS 500/50-60).

RETURN WITH BID

IV. DISCLOSURES

A. The disclosures hereinafter made by the bidder are each a material representation of fact upon which reliance is placed should the Department enter into the contract with the bidder. The Department may terminate the contract if it is later determined that the bidder rendered a false or erroneous disclosure, and the surety providing the performance bond shall be responsible for completion of the contract.

B. Financial Interests and Conflicts of Interest

1. Section 50-35 of the Illinois Procurement Code provides that all bids of more than \$10,000 shall be accompanied by disclosure of the financial interests of the bidder. This disclosed information for the successful bidder, will be maintained as public information subject to release by request pursuant to the Freedom of Information Act.

The financial interests to be disclosed shall include ownership or distributive income share that is in excess of 5%, or an amount greater than 60% of the annual salary of the Governor, of the bidding entity or its parent entity, whichever is less, unless the contractor or bidder is a publicly traded entity subject to Federal 10K reporting, in which case it may submit its 10K disclosure in place of the prescribed disclosure. The disclosure shall include the names, addresses, and dollar or proportionate share of ownership of each person making the disclosure, their instrument of ownership or beneficial relationship, and notice of any potential conflict of interest resulting from the current ownership or beneficial interest of each person making the disclosure having any of the relationships identified in Section 50-35 and on the disclosure form.

In addition, all disclosures shall indicate any other current or pending contracts, proposals, leases, or other ongoing procurement relationships the bidding entity has with any other unit of state government and shall clearly identify the unit and the contract, proposal, lease, or other relationship.

2. Disclosure Forms. Disclosure Form A is attached for use concerning the individuals meeting the above ownership or distributive share requirements. Subject individuals should be covered each by one form. In addition, a second form (Disclosure Form B) provides for the disclosure of current or pending procurement relationships with other (non-IDOT) state agencies. **The forms must be included with each bid or incorporated by reference.**

C. Disclosure Form Instructions

Form A: For bidders that have previously submitted the information requested in Form A

The Department has retained the Form A disclosures submitted by all bidders responding to these requirements for the April 24, 1998 or any subsequent letting conducted by the Department. The bidder has the option of submitting the information again or the bidder may sign the following certification statement indicating that the information previously submitted by the bidder is, as of the date of signature, current and accurate. The Certification must be signed and dated by a person who is authorized to execute contracts for the bidding company. Before signing this certification, the bidder should carefully review its prior submissions to ensure the Certification is correct. If the Bidder signs the Certification, the Bidder should proceed to Form B instructions.

CERTIFICATION STATEMENT

I have determined that the Form A disclosure information previously submitted is current and accurate, and all forms are hereby incorporated by reference in this bid. Any necessary additional forms or amendments to previously submitted forms are attached to this bid.

(Bidding Company)

Name of Authorized Representative (type or print)

Title of Authorized Representative (type or print)

Signature of Authorized Representative

Date

Form A: For bidders who have NOT previously submitted the information requested in Form A

If the bidder is a publicly traded entity subject to Federal 10K reporting, the 10K Report may be submitted to meet the requirements of Form A. If a bidder is not subject to Federal 10K reporting, the bidder must determine if any individuals are required by law to complete a financial disclosure form. To do this, the bidder should answer each of the following questions. A "YES" answer indicates Form A must be completed. If the answer to each of the following questions is "NO", then the **NOT APPLICABLE STATEMENT** on the second page of Form A must be signed and dated by a person that is authorized to execute contracts for the bidding company. Note These questions are for assistance only and are not required to be completed.

1. Does anyone in your organization have a direct or beneficial ownership share of greater than 5% of the bidding entity or parent entity? YES _____ NO _____
2. Does anyone in your organization have a direct or beneficial ownership share of less than 5%, but which has a value greater than \$87,526.20? YES _____ NO _____
3. Does anyone in your organization receive more than \$87,526.20 of the bidding entity's or parent entity's distributive income? (Note: Distributive income is, for these purposes, any type of distribution of profits. An annual salary is not distributive income.) YES _____ NO _____
4. Does anyone in your organization receive greater than 5% of the bidding entity's or parent entity's total distributive income, but which is less than \$87,526.20? YES _____ NO _____

(Note: Only one set of forms needs to be completed per person per bid even if a specific individual would require a yes answer to more than one question.)

A "YES" answer to any of these questions requires the completion of Form A. The bidder must determine each individual in the bidding entity or the bidding entity's parent company that would cause the questions to be answered "Yes". Each form must be signed and dated by a person that is authorized to execute contracts for your organization. **Photocopied or stamped signatures are not acceptable.** The person signing can be, but does not have to be, the person for which the form is being completed. The bidder is responsible for the accuracy of any information provided.

If the answer to each of the above questions is "NO", then the **NOT APPLICABLE STATEMENT** on page 2 of Form A must be signed and dated by a person that is authorized to execute contracts for your company.

Form B: Identifying Other Contracts & Procurement Related Information Disclosure Form B must be completed for each bid submitted by the bidding entity. It must be signed by an individual who is authorized to execute contracts for the bidding entity. *Note: Signing the **NOT APPLICABLE STATEMENT** on Form A does not allow the bidder to ignore Form B. Form B must be completed, signed and dated or the bidder may be considered nonresponsive and the bid will not be accepted.*

The Bidder shall identify, by checking Yes or No on Form B, whether it has any pending contracts (including leases), bids, proposals, or other ongoing procurement relationship with any other (non-IDOT) State of Illinois agency. If "No" is checked, the bidder only needs to complete the signature box on the bottom of Form B. If "Yes" is checked, the bidder must do one of the following:

Option I: If the bidder did not submit an Affidavit of Availability to obtain authorization to bid, the bidder must list all non-IDOT State of Illinois agency pending contracts, leases, bids, proposals, and other ongoing procurement relationships. These items may be listed on Form B or on an attached sheet(s). Do not include IDOT contracts. Contracts with cities, counties, villages, etc. are not considered State of Illinois agency contracts and are not to be included. Contracts with other State of Illinois agencies such as the Department of Natural Resources or the Capital Development Board must be included. Bidders who submit Affidavits of Availability are suggested to use Option II.

Option II: If the bidder is required and has submitted an Affidavit of Availability in order to obtain authorization to bid, the bidder may write or type "See Affidavit of Availability" which indicates that the Affidavit of Availability is incorporated by reference and includes all non-IDOT State of Illinois agency pending contracts, leases, bids, proposals, and other ongoing procurement relationships. For any contracts that are not covered by the Affidavit of Availability, the bidder must identify them on Form B or on an attached sheet(s). These might be such things as leases.

D. Bidders Submitting More Than One Bid

Bidders submitting multiple bids may submit one set of forms consisting of all required Form A disclosures and one Form B for use with all bids. Please indicate in the space provided below the bid item that contains the original disclosure forms and the bid items which incorporate the forms by reference.

- The bid submitted for letting item _____ contains the Form A disclosures or Certification Statement and the Form B disclosures. The following letting items incorporate the said forms by reference:

**ILLINOIS DEPARTMENT
OF TRANSPORTATION**

**Form A
Financial Information &
Potential Conflicts of Interest
Disclosure**

Contractor Name		
Legal Address		
City, State, Zip		
Telephone Number		Fax Number (if available)

Disclosure of the information contained in this Form is required by the Section 50-35 of the Illinois Procurement Code (30 ILCS 500). Vendors desiring to enter into a contract with the State of Illinois must disclose the financial information and potential conflict of interest information as specified in this Disclosure Form. This information shall become part of the publicly available contract file. This Form A must be completed for bids in excess of \$10,000, and for all open-ended contracts. **A publicly traded company may submit a 10K disclosure in satisfaction of the requirements set forth in Form A. See Disclosure Form Instructions.**

DISCLOSURE OF FINANCIAL INFORMATION

1. Disclosure of Financial Information. The individual named below has an interest in the BIDDER (or its parent) in terms of ownership or distributive income share in excess of 5%, or an interest which has a value of more than \$87,526.20 (60% of the Governor’s salary as of 10/1/2000). **(Make copies of this form as necessary and attach a separate Disclosure Form A for each individual meeting these requirements)**

FOR INDIVIDUAL (type or print information)	
NAME:	_____
ADDRESS	_____
Type of ownership/distributable income share:	
stock _____	sole proprietorship _____
partnership _____	other: (explain on separate sheet): _____
% or \$ value of ownership/distributable income share: _____	

2. Disclosure of Potential Conflicts of Interest. Check “Yes” or “No” to indicate which, if any, of the following potential conflict of interest relationships apply. If the answer to any question is “Yes”, please attach additional pages and describe.

(a) State employment, currently or in the previous 3 years, including contractual employment of services.
Yes _____ No _____

(b) State employment of spouse, father, mother, son, or daughter, including contractual employment for services in the previous 2 years.
Yes _____ No _____

(c) Elective status; the holding of elective office of the State of Illinois, the government of the United States, any unit of local government authorized by the Constitution of the State of Illinois or the statutes of the State of Illinois currently or in the previous 3 years.
Yes _____ No _____

(d) Relationship to anyone holding elective office currently or in the previous 2 years; spouse, father, mother, son, or daughter
Yes _____ No _____

RETURN WITH BID/OFFER

(e) Appointive office; the holding of any appointive government office of the State of Illinois, the United States of America, or any unit of local government authorized by the Constitution of the State of Illinois or the statutes of the State of Illinois, which office entitles the holder to compensation in excess of the expenses incurred in the discharge of that office currently or in the previous 3 years.

Yes _____ No _____

(f) Relationship to anyone holding appointive office currently or in the previous 2 years; spouse, father, mother, son, or daughter.

Yes _____ No _____

(g) Employment, currently or in the previous 3 years, as or by any registered lobbyist of the State government.

Yes _____ No _____

(h) Relationship to anyone who is or was a registered lobbyist in the previous 2 years; spouse, father, mother, son, or daughter.

Yes _____ No _____

(i) Compensated employment, currently or in the previous 3 years, by any registered election or reelection committee registered with the Secretary of State or any county clerk of the State of Illinois, or any political action committee registered with either the Secretary of State or the Federal Board of Elections.

Yes _____ No _____

(j) Relationship to anyone; spouse, father, mother, son, or daughter; who was a compensated employee in the last 2 years by any registered election or re-election committee registered with the Secretary of State or any county clerk of the State of Illinois, or any political action committee registered with either the Secretary of State or the Federal Board of Elections.

Yes _____ No _____

APPLICABLE STATEMENT

This Disclosure Form A is submitted on behalf of the INDIVIDUAL named on previous page.

Completed by:

Name of Authorized Representative (type or print)

Completed by:

Title of Authorized Representative (type or print)

Completed by:

_____ Date
Signature of Individual or Authorized Representative

NOT APPLICABLE STATEMENT

I have determined that no individuals associated with this organization meet the criteria that would require the completion of this Form A.

This Disclosure Form A is submitted on behalf of the CONTRACTOR listed on the previous page.

Name of Authorized Representative (type or print)

Title of Authorized Representative (type or print)

_____ Date
Signature of Authorized Representative

**ILLINOIS DEPARTMENT
OF TRANSPORTATION**

**Form B
Other Contracts &
Procurement Related Information
Disclosure**

Contractor Name		
Legal Address		
City, State, Zip		
Telephone Number		Fax Number (if available)

Disclosure of the information contained in this Form is required by the Section 50-35 of the Illinois Procurement Act (30 ILCS 500). This information shall become part of the publicly available contract file. This Form B must be completed for bids in excess of \$10,000, and for all open-ended contracts.

DISCLOSURE OF OTHER CONTRACTS AND PROCUREMENT RELATED INFORMATION

1. Identifying Other Contracts & Procurement Related Information. The BIDDER shall identify whether it has any pending contracts (including leases), bids, proposals, or other ongoing procurement relationship with any other State of Illinois agency: Yes _____ No _____

If **“No”** is checked, the bidder only needs to complete the signature box on the bottom of this page.

2. If “Yes” is checked. Identify each such relationship by showing State of Illinois agency name and other descriptive information such as bid or project number (attach additional pages as necessary). SEE DISCLOSURE FORM INSTRUCTIONS:

THE FOLLOWING STATEMENT MUST BE SIGNED

Name of Authorized Representative (type or print)	

Title of Authorized Representative (type or print)	
_____	_____
Signature of Authorized Representative	Date

RETURN WITH BID

SPECIAL NOTICE TO CONTRACTORS

The following requirements of the Illinois Department of Human Rights' Rules and Regulations are applicable to bidders on all construction contracts advertised by the Illinois Department of Transportation:

CONSTRUCTION EMPLOYEE UTILIZATION PROJECTION

- (a) All bidders on construction contracts shall complete and submit, along with and as part of their bids, a Bidder's Employee Utilization Form (Form BC-1256) setting forth a projection and breakdown of the total workforce intended to be hired and/or allocated to such contract work by the bidder including a projection of minority and female employee utilization in all job classifications on the contract project.
- (b) The Department of Transportation shall review the Employee Utilization Form, and workforce projections contained therein, of the contract awardee to determine if such projections reflect an underutilization of minority persons and/or women in any job classification in accordance with the Equal Employment Opportunity Clause and Section 7.2 of the Illinois Department of Human Rights' Rules and Regulations for Public Contracts adopted as amended on September 17, 1980. If it is determined that the contract awardee's projections reflect an underutilization of minority persons and/or women in any job classification, it shall be advised in writing of the manner in which it is underutilizing and such awardee shall be considered to be in breach of the contract unless, prior to commencement of work on the contract project, it submits revised satisfactory projections or an acceptable written affirmative action plan to correct such underutilization including a specific timetable geared to the completion stages of the contract.
- (c) The Department of Transportation shall provide to the Department of Human Rights a copy of the contract awardee's Employee Utilization Form, a copy of any required written affirmative action plan, and any written correspondence related thereto. The Department of Human Rights may review and revise any action taken by the Department of Transportation with respect to these requirements.

RETURN WITH BID



PART I. IDENTIFICATION

Human Rights

Bid Number: _____ Duration of Project: _____

Name of Bidder: _____

PART II. WORKFORCE PROJECTION

A. The undersigned bidder has analyzed minority group and female populations, unemployment rates and availability of workers for the location in which this contract work is to be performed, and for the locations from which the bidder recruits employees, and hereby submits the following workforce projection including a projection for minority and female employee utilization in all job categories in the workforce to be allocated to this contract:

TABLE A

TOTAL Workforce Projection for Contract												
JOB CATEGORIES	TOTAL EMPLOYEES		MINORITY EMPLOYEES						TRAINEES			
			BLACK		HISPANIC		*OTHER MINOR.		APPRENTICES		ON THE JOB TRAINEES	
	M	F	M	F	M	F	M	F	M	F	M	F
OFFICIALS (MANAGERS)												
SUPERVISORS												
FOREMEN												
CLERICAL												
EQUIPMENT OPERATORS												
MECHANICS												
TRUCK DRIVERS												
IRONWORKERS												
CARPENTERS												
CEMENT MASONS												
ELECTRICIANS												
PIPEFITTERS, PLUMBERS												
PAINTERS												
LABORERS, SEMI-SKILLED												
LABORERS, UNSKILLED												
TOTAL												

TABLE B

CURRENT EMPLOYEES TO BE ASSIGNED TO CONTRACT					
TOTAL EMPLOYEES			MINORITY EMPLOYEES		
M	F		M	F	

TABLE C

TOTAL Training Projection for Contract								
EMPLOYEES IN TRAINING	TOTAL EMPLOYEES		BLACK		HISPANIC		*OTHER MINOR.	
	M	F	M	F	M	F	M	F
APPRENTICES								
ON THE JOB TRAINEES								

*Other minorities are defined as Asians (A) or Native Americans (N).
Please specify race of each employee shown in Other Minorities column.

Note: See instructions on page 2

FOR DEPARTMENT USE ONLY

RETURN WITH BID

PART II. WORKFORCE PROJECTION - continued

- B. Included in "Total Employees" under Table A is the total number of **new hires** that would be employed in the event the undersigned bidder is awarded this contract.

The undersigned bidder projects that: (number) _____ new hires would be recruited from the area in which the contract project is located; and/or (number) _____ new hires would be recruited from the area in which the bidder's principal office or base of operation is located.

- C. Included in "Total Employees" under Table A is a projection of numbers of persons to be employed directly by the undersigned bidder as well as a projection of numbers of persons to be employed by subcontractors.

The undersigned bidder estimates that (number) _____ persons will be directly employed by the prime contractor and that (number) _____ persons will be employed by subcontractors.

PART III. AFFIRMATIVE ACTION PLAN

- A. The undersigned bidder understands and agrees that in the event the foregoing minority and female employee utilization projection included under **PART II** is determined to be an underutilization of minority persons or women in any job category, and in the event that the undersigned bidder is awarded this contract, he/she will, prior to commencement of work, develop and submit a written Affirmative Action Plan including a specific timetable (geared to the completion stages of the contract) whereby deficiencies in minority and/or female employee utilization are corrected. Such Affirmative Action Plan will be subject to approval by the contracting agency and the **Department of Human Rights**.
- B. The undersigned bidder understands and agrees that the minority and female employee utilization projection submitted herein, and the goals and timetable included under an Affirmative Action Plan if required, are deemed to be part of the contract specifications.

Company _____ Telephone Number _____

 Address _____

NOTICE REGARDING SIGNATURE

The Bidder's signature on the Proposal Signature Sheet will constitute the signing of this form. The following signature block needs to be completed only if revisions are required.

Signature: _____ Title: _____ Date: _____

- Instructions: All tables must include subcontractor personnel in addition to prime contractor personnel.
- Table A - Include both the number of employees that would be hired to perform the contract work and the total number currently employed (Table B) that will be allocated to contract work, and include all apprentices and on-the-job trainees. The "Total Employees" column should include all employees including all minorities, apprentices and on-the-job trainees to be employed on the contract work.
 - Table B - Include all employees currently employed that will be allocated to the contract work including any apprentices and on-the-job trainees currently employed.
 - Table C - Indicate the racial breakdown of the total apprentices and on-the-job trainees shown in Table A.

RETURN WITH BID

CERTIFICATIONS REQUIRED BY STATE AND/OR FEDERAL LAW. The bidder is required by State and/or Federal law to make the below certifications and assurances as a part of the proposal and contract upon award. It is understood by the bidder that the certifications and assurances made herein are a part of the contract.

By signing the Proposal Signature Sheet, the bidder certifies that he/she has read and completed each of the following certifications and assurances, that required responses are true and correct and that the certified signature of the Proposal Signature Sheet constitutes an endorsement and execution of each certification and assurance as though each was individually signed:

A. By the execution of this proposal, the signing bidder certifies that the bidding entity has not, either directly or indirectly, entered into any agreement, participated in any collusion, or otherwise taken any action, in restraint of free competitive bidding in connection with the submitted bid. This statement made by the undersigned bidder is true and correct under penalty of perjury under the laws of the United States.

B. **CERTIFICATION, EQUAL EMPLOYMENT OPPORTUNITY:**

1. Have you participated in any previous contracts or subcontracts subject to the equal opportunity clause.
YES _____ NO _____

2. If answer to #1 is yes, have you filed with the Joint Reporting Committee, the Director of OFCC, any Federal agency, or the former President's Committee on Equal Employment Opportunity, all reports due under the applicable filing requirements of those organizations? YES _____ NO _____

C. **BUY AMERICAN - STEEL AND MANUFACTURED PRODUCTS FOR CONSTRUCTION CONTRACTS (JAN 1991)**

(a) The Aviation Safety and Capacity Expansion Act of 1990 provides that preference be given to steel and manufactured products produced in the United States when funds are expended pursuant to a grant issued under the Airport Improvement Program. The following terms apply:

1. Steel and manufactured products. As used in this clause, steel and manufactured products include (1) steel produced in the United States or (2) a manufactured product produced in the United States, if the cost of its components mined, produced or manufactured in the United States exceeds 60 percent of the cost of all its components and final assembly has taken place in the United States. Components of foreign origin of the same class or kind as the products referred to in subparagraphs (b)(1) or (2) shall be treated as domestic.

2. Components. As used in this clause, components means those articles, materials, and supplies incorporated directly into steel and manufactured products.

3. Cost of Components. This means the costs for production of the components, exclusive of final assembly labor costs.

(b) The successful bidder will be required to assure that only domestic steel and manufactured products will be used by the Contractor, subcontractors, materialmen, and suppliers in the performance of this contract, except those-

- (1) that the U.S. Department of Transportation has determined, under the Aviation Safety and Capacity Expansion Act of 1990, are not produced in the United States in sufficient and reasonably available quantities of a satisfactory quality;

- (2) that the U.S. Department of Transportation has determined, under the Aviation Safety and Capacity Expansion Act of 1990, that domestic preference would be inconsistent with the public interest; or

- (3) that inclusion of domestic material will increase the cost of the overall project contract by more than 25 percent.

(End of Clause)

RETURN WITH BID

D. BUY AMERICAN CERTIFICATE (JAN 1991)

By submitting a bid/proposal under this solicitation, except for those items listed by the offeror below or on a separate and clearly identified attachment to this bid/proposal, the offeror certifies that steel and each manufactured product, is produced in the United States (as defined in the clause Buy American - Steel and Manufactured Products or Buy American - Steel and Manufactured Products For Construction Contracts) and that components of unknown origin are considered to have been produced or manufactured outside the United States.

Offerors may obtain from (IDOT, Division of Aeronautics) lists of articles, materials, and supplies excepted from this provision.

PRODUCT

COUNTRY OF ORIGIN

E. NPDES CERTIFICATION

In accordance with the provisions of the Illinois Environmental Protection Act, the Illinois Pollution Control Board Rules and Regulations (35 Ill. Adm. Code, Subtitle C, Chapter I), and the Clean Water Act, and the regulations thereunder, this certification is required for all construction contracts that will result in the disturbance of five or more acres total land area.

The undersigned bidder certifies under penalty of law that he/she understands the terms and conditions of the general National Pollutant Discharge Elimination System (NPDES) permit (ILR100000) that authorizes the storm water discharges associated with industrial activity from the construction site identified as part of this certification.

The Airport Owner or its Agent will:

- 1) prepare, sign and submit the Notice of Intent (NOI)
- 2) conduct site inspections and complete and file the inspection reports
- 3) submit Incidence of Non-Compliance (ION) forms
- 4) submit Notice of Termination (NOT) form

Prior to the issuance of the Notice-to-Proceed, for each erosion control measure identified in the Storm Water Pollution Prevention Plan, the contractor or subcontractor responsible for the control measure(s) must sign the above certification (forms to be provided by the Department).

F. NON-APPROPRIATION CLAUSE

By submitting a bid/proposal under this solicitation the offeror certifies that he/she understands that obligations of the State will cease immediately without penalty or further payment being required in any fiscal year the Illinois General Assembly fails to appropriate or otherwise make available sufficient funds for this contract.

G. Contractor is not delinquent in the payment of any debt to the State (or if delinquent has entered into a deferred payment plan to pay the debt), and Contractor acknowledges the contracting state agency may declare the contract void if this certification is false (30 ILCS 500/50-11, effective July 1, 2002).

RETURN WITH BID

NOTICE TO BIDDERS

- 1. TIME AND PLACE OF OPENING BIDS.** Sealed proposals for the improvement described herein will be received by the Department of Transportation at the Harry R. Hanley Building, 2300 South Dirksen Parkway in Springfield, Illinois until 10:00 o'clock a.m., March 6, 2009. All bids will be gathered, sorted, publicly opened and read in the auditorium at the Department of Transportation's Harry R. Hanley Building shortly after the 10:00 a.m. cut off time.
- 2. DESCRIPTION OF WORK.** The proposed improvement, shown in detail on the plans issued by the Department includes, in general, the following described work:

Construct Southeast Quadrant Fire Protection

- 3. INSTRUCTIONS TO BIDDERS.** (a) This Notice, the invitation for bids, proposal and award shall, together with all other documents in accordance with Article 10-15 of the Illinois Standard Specifications for Construction of Airports, become part of the contract. Bidders are cautioned to read and examine carefully all documents, to make all required inspections, and to inquire or seek explanation of the same prior to submission of a bid.

(b) State law, and, if the work is to be paid wholly or in part with Federal-aid funds, Federal law requires the bidder to make various certifications as a part of the proposal and contract. By execution and submission of the proposal, the bidder makes the certification contained therein. A false or fraudulent certification shall, in addition to all other remedies provided by law, be a breach of contract and may result in termination of the contract.
- 4. AWARD CRITERIA AND REJECTION OF BIDS.** This contract will be awarded to the lowest responsive and responsible bidder considering conformity with the terms and conditions established by the Department in the proposal and contract documents. The issuance of plans and proposal forms for bidding based upon a prequalification rating shall not be the sole determinant of responsibility. The Department reserves the right to determine responsibility at the time of award, to reject any or all proposals, to readvertise the proposed improvement, and to waive technicalities.
- 5. PRE-BID CONFERENCE.** There will be a pre-bid conference held at N/A at the Greater Kankakee Airport administration building. For engineering information, contact Matt Demos of Crawford, Murphy & Tilly, Inc. at (312) 855-2540.
- 6. DISADVANTAGED BUSINESS POLICY.** The DBE goal for this contract is 12.0%.
- 7. SPECIFICATIONS AND DRAWINGS.** The work shall be done in accordance with the Illinois Standard Specifications for Construction of Airports, the Illinois Division of Aeronautics Supplemental Specifications and Recurring Special Provisions, the Special Provisions dated January 26, 2007 and the Construction Plans dated January 26, 2007 as approved by the Department of Transportation, Division of Aeronautics.

RETURN WITH BID

- 8. INSPECTION OF RECORDS.** The Contractor shall maintain an acceptable cost accounting system. The Sponsor, the FAA, and the Comptroller General of the United States shall have access to any books, documents, paper, and records of the Contractor which are directly pertinent to the specific contract for the purposes of making an audit, examination, excerpts, and transcriptions. The Contractor shall maintain all required records for three years after the Sponsor makes final payment and all other pending matters are closed.
- 9. RIGHTS TO INVENTIONS.** All rights to inventions and materials generated under this contract are subject to Illinois law and to regulations issued by the FAA and the Sponsor of the Federal grant under which this contract is executed. Information regarding these rights is available from the FAA and the Sponsor.
- 10. TERMINATION OF CONTRACT.**
1. The Sponsor may, by written notice, terminate this contract in whole or in part at any time, either for the Sponsor's convenience or because of failure to fulfill the contract obligations. Upon receipt of such notice services shall be immediately discontinued (unless the notice directs otherwise) and all materials as may have been accumulated in performing this contract, whether completed or in progress, delivered to the Sponsor.
 2. If the termination is for the convenience of the Sponsor, an equitable adjustment in the contract price shall be made, but no amount shall be allowed for anticipated profit on unperformed services.
 3. If the termination is due to failure to fulfill the Contractor's obligations, the Sponsor may take over the work and prosecute the same to completion by contract or otherwise. In such case, the Contractor shall be liable to the Sponsor for any additional cost occasioned to the Sponsor thereby.
 4. If, after notice of termination for failure to fulfill contract obligations, it is determined that the Contractor had not so failed, the termination shall be deemed to have been effected for the convenience of the Sponsor. In such event, adjustment in the contract price shall be made as provided in paragraph 2 of this clause.
 5. The rights and remedies of the sponsor provided in this clause are in addition to any other rights and remedies provided by law or under this contract.

RETURN WITH BID

11. BIDDING REQUIREMENTS AND BASIS OF AWARD. When alternates are included in the proposal, the following shall apply:

a. Additive Alternates

- (1) Bidders must submit a bid for the Base Bid and for all Additive Alternates.
- (2) Award of this contract will be made to the lowest responsible qualified bidder computed as follows:

The lowest aggregate amount of (i) the Base Bid plus (ii) any Additive Alternate(s) which the Department elects to award.

The Department may elect not to award any Additive Alternates. In that case, award will be to the lowest responsible qualified bidder of the Base Bid.

b. Optional Alternates

- (1) Bidders must submit a bid for the Base Bid and for either Alternate A or Alternate B or for both Alternate A and Alternate B.
- (2) Award of this contract will be made to the lowest responsible qualified bidder computed as follows:

The lower of the aggregate of either (i) the Base Bid plus Alternate A or (ii) the Base Bid plus Alternate B.

12. CONTRACT TIME. The Contractor shall complete all work within the specified contract time. Any calendar day extension beyond the specified contract time must be fully justified, requested by the Contractor in writing, and approved by the Engineer, or be subject to liquidated damages.

The contract time for this contract is 31 calendar days.

13. INDEPENDENT WEIGHT CHECKS. The Department reserves the right to conduct random unannounced independent weight checks on any delivery for bituminous, aggregate or other pay item for which the method of measurement for payment is based on weight. The weight checks will be accomplished by selecting, at random, a loaded truck and obtaining a loaded and empty weight on an independent scale. In addition, the department may perform random weight checks by obtaining loaded and empty truck weights on portable scales operated by department personnel.

14. GOOD FAITH COMPLIANCE. The Illinois Department of Transportation has made a good faith effort to include all statements, requirements, and other language required by federal and state law and by various offices within federal and state governments whether that language is required by law or not. If anything of this nature has been left out or if additional language etc. is later required, the bidder/contractor shall cooperate fully with the Department to modify the contract or bid documents to correct the deficiency. If the change results in increased operational costs, the Department shall reimburse the contractor for such costs as it may find to be reasonable.

RETURN WITH BID

PROPOSAL SIGNATURE SHEET

The undersigned bidder hereby makes and submits this bid on the subject Proposal, thereby assuring the Department that all requirements of the Invitation for Bids and rules of the Department have been met, that there is no misunderstanding of the requirements of paragraph 4 of this Proposal, and that the contract will be executed in accordance with the rules of the Department if an award is made on this bid.

Firm Name _____

(IF AN INDIVIDUAL)

Signature of Owner _____

Business Address _____

Firm Name _____

By _____

(IF A CO-PARTNERSHIP)

Business Address _____

Name and Address of All Members of the Firm:

Corporate Name _____

Corporate Seal

By _____

President

(IF A CORPORATION)

Attest _____

Corporate Secretary

Business Address _____

Name of Corporate Officers:

President Corporate Secretary Treasurer

NOTARY CERTIFICATION

STATE OF ILLINOIS,

ALL SIGNATURES MUST BE NOTARIZED

COUNTY OF _____

I, _____, a Notary Public in and for said county, do hereby certify that _____

AND _____

(Insert names of individual(s) signing on behalf of bidder)

who are each personally known to me to be the same persons whose names are subscribed to the foregoing instrument on behalf of the bidder, appeared before me this day in person and acknowledged that they signed, sealed, and delivered said instrument as their free and voluntary act for the uses and purposes therein set forth.

Given under my hand and notarial seal this _____ day of _____, A.D. _____

My commission expires _____ (Seal)

Notary Public



Return with Bid

Division of Aeronautics
Proposal Bid Bond
(Effective January 1, 2002)

Item No. 9A
Letting Date: March 6, 2009

Airport: Greater Kankakee Airport
Ill. Proj. No. IKK-3661
Fed. Proj. No. 3-17-0057-B13

KNOW ALL MEN BY THESE PRESENTS. that we, _____, as PRINCIPAL, and _____, as SURETY are held and

firmly bound unto the, hereinafter called the SPONSOR, in the penal sum of 5 percent of the total bid price or of the amount specified in Section 6, PROPOSAL GUARANTEE of the Proposal Document, whichever is the lesser sum, well and truly to be paid unto the said SPONSOR, for the payment of which we bind ourselves, our heirs, executors, administrators, successors, and assigns.

THE CONDITION OF THIS OBLIGATION IS SUCH, that whereas the PRINCIPAL has submitted a Bid Proposal to the SPONSOR through its AGENT, the State of Illinois, Department of Transportation, Division of Aeronautics, for the improvement designated by the Transportation Bulletin Item Number and Letting Date indicated above;

NOW, THEREFORE, if the SPONSOR through its AGENT shall accept the Bid Proposal of the PRINCIPAL; and if PRINCIPAL shall within the time and as specified in the Bidding and Contract Documents, submit the DBE Utilization Plan that is acceptable and approved by the AGENT, and if after the award, the PRINCIPAL shall enter into a contract in accordance with the terms of the Bidding and Contract Documents including evidence of insurance coverage's and providing such bond as specified with good and sufficient surety for the faithful performance of such contract and for prompt payment of labor and material furnished in the prosecution thereof; or if, in the event of the failure of the PRINCIPAL to make the required DBE submission or to enter into such contract and to give the specified bond, the PRINCIPAL pays to the SPONSOR the difference not to exceed the penalty hereof between the amount in the Bid Proposal and such larger amount for which the SPONSOR may contract with another party to perform the work covered by said Proposal Document, then, this obligation to be void; otherwise to remain in full force and effect.

IN THE EVENT the SPONSOR acting through its AGENT determines the PRINCIPAL has failed to comply with any requirement as set forth in the preceding paragraph, then the SURETY shall pay the penal sum to the SPONSOR within fifteen (15) days of written demand therefor. If the SURETY does not make full payment within such period of time, the AGENT may bring an action to collect the amount owed. The SURETY is liable to the SPONSOR and to the AGENT for all its expenses, including attorney's fees, incurred in any litigation in which SPONSOR or AGENT prevail either in whole or in part.

IN WITNESS WHEREOF, the said PRINCIPAL and the said SURETY have caused this instrument to be signed by

their respective officers this _____ day of _____ A.D., 20 ____.

PRINCIPAL

SURETY

(Company Name)

(Company Name)

By: _____ (Signature & Title)

By: _____ (Signature of Attorney-in-Fact)

Notary Certification for Principal and Surety

State of Illinois)
) ss:
County of _____)

I, _____, a Notary Public in and for said County, do hereby certify that

_____ and _____
(Insert names of individuals signing on behalf of PRINCIPAL & SURETY)

who are each personally known to me to be the same persons whose names are subscribed to the foregoing instrument on behalf of PRINCIPAL and SURETY, appeared before me this day in person and acknowledged respectively, that they signed and delivered said instrument as their free and voluntary act for uses and purposes therein set forth.

Given under my hand and notary seal this _____ day of _____ A.D., 20 ____

My commission expires _____ (Notary Public)

In lieu of completing the above section of the Proposal Bid Form, the PRINCIPAL may file an Electronic Bid Bond. By signing below, the PRINCIPAL is ensuring the identified electronic bid bond has been executed and the PRINCIPAL and SURETY are firmly bound to the SPONSOR through its AGENT under the conditions of the Bid Bond as shown above.

Electronic Bid Bond ID#

Company/Bidder Name

Signature and Title
Form D.E. (Rev. 12-2001)



PROPOSALS

for construction work advertised for bids by the
Illinois Department of Transportation

Item No.	Item No.	Item No.

Submitted By:

Name:
Address:
Phone No.

Bidders should affix this form to the front of a 10" x 13" envelope and use that envelope for the submittal of bids. If proposals are mailed, they should be enclosed in a second or outer envelope addressed to:

Engineer of Design and Environment - Room 323
Illinois Department of Transportation
2300 South Dirksen Parkway
Springfield, Illinois 62764

CONTRACTOR OFFICE COPY OF CONTRACT SPECIFICATIONS

NOTICE

None of the following material needs to be returned with the bid package unless the special provisions require documentation and/or other information to be submitted.



Illinois Department of Transportation

CONTRACT REQUIREMENTS

(1) Airport Improvement Program projects. The work in this contract is included in the federal Airport Improvement Program and is being undertaken and accomplished by the Illinois Department of Transportation, Division of Aeronautics and the Municipality, hereinafter called the Co-Sponsors, in accordance with the terms and conditions of a Grant Agreement between the Co-Sponsors and the United States, under the Airport and Airway Improvement Act of 1982 (Public Law 97-248; Title V, Section 501 et seq., September 3, 1982; 96 Stat. 671; codified at 49 U.S.C Section 2201 et seq.) and Part 152 of the Federal Aviation Regulations (14 CFR Part 152), pursuant to which the United States has agreed to pay a certain percentage of the costs of the Project that are determined to be allowable Project costs under the Act. The United States is not a party to this contract and no reference in this contract to FAA or representative thereof, or to any rights granted to the FAA or any representative thereof, or the United States, by the contract, makes the United States a party to this contract.

(2) Consent of Assignment. The Contractor shall obtain the prior written consent of the Co-Sponsors to any proposed assignment of any interest in or part of this contract.

(3) Convict Labor. No convict labor may be employed under this contract.

(4) Veterans Preference. In the employment of labor, except in executive, administrative, and supervisory positions, preference shall be given to veterans of the Vietnam era and disabled veterans as defined in Section 515(c) of the Airport and Airway Improvement Act of 1982. However, this preference shall apply only where the individuals are available and qualified to perform the work to which the employment relates.

(5) Withholding: Sponsor from Contractor. Whether or not payments or advances to the Co-Sponsors are withheld or suspended by the FAA, the Co-Sponsors may withhold or cause to be withheld from the Contractor so much of the accrued payments or advances as may be considered necessary to pay laborers and mechanics employed by the Contractor or any subcontractor on the work the full amount of wages required by this contract.

(6) Nonpayment of Wages. If the Contractor or subcontractor fails to pay any laborer or mechanic employed or working on the site of the work any of the wages required by this contract the Co-Sponsors may, after written notice to the Contractor, take such action as may be necessary to cause the suspension of any further payment or advance of funds until the violations cease.

(7) FAA Inspection and Review. The Contractor shall allow any authorized representative of the FAA to inspect and review any work or materials used in the performance of this contract.

(8) Subcontracts. The Contractor shall insert in each of his subcontracts the provisions contained in Paragraphs (1), (3), (4), (5), (6), and (7) above and also a clause requiring the subcontractors to include these provisions in any lower tier subcontracts which they may enter into, together with a clause requiring this insertion in any further subcontracts that may in turn be made.

(9) Contract Termination. A breach of Paragraph (6), (7), and (8) above may be grounds for termination of the contract.

PROVISIONS REQUIRED BY THE REGULATIONS OF THE SECRETARY OF LABOR 29 CFR 5.5

(a) Contract Provisions and Related Matters.

(1) Minimum Wages.

Revised 1/92

(i) All laborers and mechanics employed or working upon the site of the work will be paid unconditionally and not less often than once a week, and without subsequent deduction or rebate on any account (except such payroll deductions as are permitted by regulations issued by the Secretary of Labor under the Copeland Act (29 CFR Part 3)), the full amount of wages and bona fide fringe benefits (or cash equivalents thereof) due at time of payment computed at rates not less than those contained in the wage determination of the Secretary of Labor which is attached hereto and made a part hereof, regardless of any contractual relationship which may be alleged to exist between the Contractor and such laborers and mechanics. Contributions made or costs reasonably anticipated for bona fide fringe benefits under section 1(b)(2) of the Davis-Bacon Act on behalf of laborers or mechanics are considered wages paid to such laborers or mechanics, subject to the provision of paragraph (a)(1)(iv) of this section; also, regular contributions made or costs incurred for more than a weekly period (but not less often than quarterly) under plans, funds, or programs which cover the particular weekly period, are deemed to be constructively made or incurred during such weekly period. Such laborers and mechanics shall be paid the appropriate wage rate and fringe benefits on the wage determination for the classification of work actually performed, without regard to skill, except as provided in paragraph 5.5(a)(4). Laborers or mechanics performing work in more than one classification may be compensated at the rate specified for each classification for the time actually worked therein: provided, that the employer's payroll records accurately set forth the time spent in each classification in which work is performed. The wage determination (including any additional classification and wage rates conformed under paragraph (a)(1)(ii) of this section) and the Davis-Bacon poster (WH-1321) shall be posted at all times by the Contractor and its subcontractors at the site of the work in a prominent and accessible place where it can be easily seen by the workers.

(ii)(A) The contracting officer shall require that any class of laborers or mechanics which is not listed in the wage determination and which is to be employed under the contract shall be classified in conformance with the wage determination. The contracting officer shall approve an additional classification and wage rate and fringe benefits therefor only when the following criteria have been met:

- (1) The work to be performed by the classification requested is not performed by a classification in the wage determination; and
- (2) The classification is utilized in the area by the construction industry; and
- (3) The proposed wage rate, including any bona fide fringe benefits, bears a reasonable relationship to the wage rates contained in the wage determination.

(ii)(B) If the Contractor and the laborers and mechanics to be employed in the classification (if known), or their representatives, and the contracting officer agree on the classification and wage rate (including the amount designated for fringe benefits where appropriate), a report of the action taken shall be sent by the contracting officer to the Administrator of the Wage and Hour Division, Employment Standards Administration, U.S. Department of Labor, Washington, D.C. 20210. The Administrator, or an authorized representative, will approve, modify, or disapprove every additional classification action within 30 days of receipt and so advise the contracting officer or will notify the contracting officer within the 30-day period that additional time is necessary. (Approved by the Office of Management and Budget under OMB control number 1215-0140).

(ii)(C) In the event the Contractor, the laborers or mechanics to be employed in the classification or their representatives, and the contracting officer do not agree on the proposed classification and wage rate (including the amount designated for fringe benefits, where appropriate), the contracting officer shall refer the questions, including the views of all interested parties and the recommendation of the contracting officer, to the Administrator for determination. The Administrator, or an authorized representative, will issue a determination within 30 days of receipt and so advise the contracting officer or will notify the contracting officer within the 30-day period that additional time is necessary. (Approved by the Office of Management and Budget under OMB control number 1215-0140).

(ii)(D) The wage rate (including fringe benefits where appropriate) determined pursuant to subparagraphs (1)(B) or (C) of this paragraph, shall be paid to all workers performing work in the classification under this contract from the first day on which work is performed in the classification.

(iii) Whenever the minimum wage rate prescribed in the contract for a class of laborers or mechanics includes a fringe benefit which is not expressed as an hourly rate, the Contractor shall either pay the benefit as stated in the wage determination or shall pay another bona fide fringe benefit or an hourly cash equivalent thereof.

(iv) If the Contractor does not make payments to a trustee or other third person, the Contractor may consider as part of the wages of any laborer or mechanic the amount of any costs reasonably anticipated in providing bona fide fringe benefits under a plan or program, provided, that the Secretary of Labor has found, upon the written request of the Contractor, that the applicable standards of the Davis-Bacon Act have been met. The Secretary of Labor may require the Contractor to set aside in a separate account assets for the meeting of obligations under the plan or program. (Approved by the Office of Management and Budget under OMB control number 1215-0140).

(2) Withholding. The Federal Aviation Administration shall upon its own action or written request of an authorized representative of the Department of Labor withhold or cause to be withheld from the Contractor under this contract or any other Federal contract with the same prime Contractor, or any other Federally-assisted contract subject to Davis-Bacon prevailing wage requirements, which is held by the same prime Contractor, so much of the accrued payments or advances as may be considered necessary to pay laborers and mechanics, including apprentices, trainees, and helpers, employed by the Contractor or any subcontractor the full amount of wages required by the contract. In the event of failure to pay any laborer or mechanic, including any apprentice, trainee, or helper, employed or working on the site of the work, all or part of the wages required by the contract, the (Agency) may, after written notice to the Contractor, sponsor, applicant, or owner, take such action as may be necessary to cause the suspension of any further payment, advance, or guarantee of funds until such violations have ceased.

(3) Payrolls and basic records.

(i) Payrolls and basic records relating thereto shall be maintained by the Contractor during the course of the work and preserved for a period of three years thereafter for all laborers and mechanics working at the site of the work. Such records shall contain the name, address, and social security number of each such work, his or her correct classification, hourly rates of wages paid (including rates of contributions or costs anticipated for bona fide fringe benefits or cash equivalents thereof of the types described in section 1(b)(2)(B) of the Davis-Bacon Act), daily and weekly number of hours worked, deductions made and actual wages paid. Whenever the Secretary of Labor has found under 29 CFR 5.5(a)(1)(iv) that the wages of any laborer or mechanic include the amount of any costs reasonably anticipated in providing benefits under a plan or program described in section 1(b)(2)(B) of the Davis-Bacon Act, the Contractor shall maintain records which show that the commitment to provide such benefits is enforceable, that the plan or program is financially responsible, and that the plan or program has been communicated in writing to the laborers or mechanics affected, and records which show the costs anticipated or the actual cost incurred in providing such benefits. Contractors employing apprentices or trainees under approved programs shall maintain written evidence of the registration of apprenticeship programs and certification of trainee programs, the registration of the apprentices and trainees, and the ratios and wage rates prescribed in the applicable programs. (Approved by the Office Management and Budget under OMB control numbers 1215-0140 and 1215-0017).

(ii)(A) The Contractor shall submit weekly for each week in which any contract work is performed a copy of all payrolls to the Federal Aviation Administration if the agency is a party to the contract, but if the agency is not such a party, the Contractor will submit the payrolls to the applicant, sponsor, or owner, as the case may be, for transmission to the Federal Aviation Administration. The payrolls submitted shall set out accurately and completely all of the information required to be maintained under paragraph 5.5(a)(3)(i) of Regulations, 29 CFR Part 5. This information may be submitted in any form desired.

Optional Form WH-347 is available for this purpose and may be purchased from the Superintendent of Documents (Federal Stock Number 029-005-00014-1), U.S. Government Printing Office, Washington, D.C. 20402. The prime Contractor is responsible for the submission of copies of payrolls by all subcontractors. (Approved by the Office of Management and Budget under OMB control number 1215-0149).

(ii)(B) Each payroll submitted shall be accompanied by a "Statement of Compliance," signed by the Contractor, or subcontractor or his or her agent who pays or supervises the payment of the persons employed under the contract and shall certify the following:

(1) That the payroll for the payroll period contains the information required to be maintained under paragraph 5.5(a)(3)(i) of Regulations, 29 CFR Part 5 and that such information is correct and complete;

(2) That each laborer or mechanic (including each helper, apprentice, and trainee) employed on the contract during the payroll period has been paid the full weekly wages earned, without rebate, either directly or indirectly, and that no deductions have been made either directly or indirectly from the full wages earned, other than permissible deductions as set forth in Regulations, 29 CFR Part 3;

(3) That each laborer or mechanic has been paid not less than the applicable wage rates and fringe benefits or cash equivalents for the classification of work performed as specified in the applicable wage determination incorporated into the contract.

(ii)(C) The weekly submission of a properly executed certification set forth on the reverse side of Optional Form WH-347 shall satisfy the requirement for submission of the "Statement of Compliance" required by paragraph (a)(3)(ii)(B) of this section.

(ii)(D) The falsification of any of the above certifications may subject the Contractor or subcontractor to civil or criminal prosecution under Section 1001 of Title 18 and Section 231 of Title 31 of the United States Code.

(iii) The Contractor or subcontractor shall make the records required under paragraph (a)(3)(i) of this section available for inspection, copying, or transcription by authorized representatives of the (write the name of the agency) or the Department of Labor, and shall permit such representatives to interview employees during working hours on the job. If the Contractor or subcontractor fails to submit the required records or to make them available, the Federal agency may, after written notice to the Contractor, sponsor, applicant, or owner, take such action as may be necessary to cause the suspension of any further payment, advance, or guarantee of funds. Furthermore, failure to submit the required records upon request or to make such records available may be grounds for debarment action pursuant to 29 CFR 5.12.

(4) Apprentices and Trainees

(i) Apprentices. Apprentices will be permitted to work at less than the predetermined rate for the work they performed when they are employed pursuant to and individually registered in a bona fide apprenticeship program registered with the U.S. Department of Labor, Employment and Training Administration, Bureau of Apprenticeship and Training, or with a State Apprenticeship Agency recognized by the Bureau, or if a person is employed in his or her first 90 days of probationary employment as a apprentice in such an apprenticeship program, who is not individually registered in the program, but who has been certified by the Bureau of Apprenticeship and Training or a State Apprenticeship Agency (where appropriate) to be eligible for probationary employment as an apprentice. The allowable ratio of apprentices to journeymen on the job site in any craft classification shall not be greater than the ratio permitted to the Contractor as to the entire work force under the registered program. Any worker listed on a payroll at an apprentice wage rate, who is not registered or otherwise employed as stated above, shall be paid not less than the applicable wage rate on the wage determination for the classification of work actually performed. In addition, any apprentice performing work on the job site in excess of the ratio permitted under the registered program shall be paid not less than the applicable wage rate on the wage determination for the work actually performed. Where a Contractor is performing construction on a project in a locality other than that in which its program is registered, the ratios and wage rates (expressed in percentages of the journeyman's hourly rate) specified in the Contractor's or subcontractor's registered program shall be observed. Every apprentice must be paid at not less than the rate specified in the registered program for the apprentice's level of progress, expressed as a percentage of the journeymen hourly rate specified in the applicable wage determination. Apprentices shall be paid fringe benefits in accordance with the provisions of the apprenticeship program. If the apprenticeship program does not specify fringe benefits, apprentices must be paid the full amount of fringe benefits listed on the wage determination for the applicable classification. If the Administrator determines that a different practice prevails for the applicable apprentice classification, fringes shall be paid in accordance with that determination. In the event the Bureau of Apprenticeship and Training, or a State Apprenticeship Agency recognized by the Bureau, withdraws approval of an apprenticeship program, the Contractor will no longer be permitted to utilize apprentices at less than the applicable predetermined rate for the work performed until an acceptable program is approved.

(ii) Trainees. Except as provided in 29 CFR 5.16, trainees will not be permitted to work at less than the predetermined rate for the work performed unless they are employed pursuant to and individually registered in a program which has received prior approval, evidenced by formal certification by the U.S. Department of Labor, Employment and Training Administration. The ratio of trainees to journeymen on the job site shall not be greater than permitted under the plan approved by the Employment and Training Administration. Every trainee must be paid at not less than the rate specified in the approved program for the trainee's level of progress, expressed as a percentage of the journeyman hourly rate specified in the applicable wage determination. Trainees shall be paid fringe benefits in accordance with the provisions of the trainee program. If the trainee program does not mention fringe benefits, trainees shall be paid the full amount of fringe benefits listed on the wage determination unless the Administrator of the Wage and Hour Division determines that there is an apprenticeship program associated with the corresponding journeyman wage rate on the wage determination which provides for less than full fringe benefits for apprentices. Any employee listed on the payroll at a trainee rate who is not registered and participating in a training plan approved by the Employment and Training Administration shall be paid not less than the applicable wage rate on the wage determination for the classification of work actually performed. In addition, any trainee performing work on the job site in excess of the ration permitted under the registered program shall be paid not less than the applicable wage rate on the wage determination for the work actually performed. In the event the Employment and Training Administration withdraws approval of a training program, the contract will no longer be permitted to utilize trainees at less than the applicable predetermined rate for the work performed until an acceptable program is approved.

(iii) Equal employment opportunity. The utilization of apprentices, trainees and journeymen under this part shall be in conformity with the equal employment opportunity requirements of Executive Order 11246, as amended, and 29 CFR Part 30.

(5) Compliance with Copeland Act requirements. The Contractor shall comply with the requirements of 29 CFR Part 3, which are incorporated by reference in this contract.

(6) Subcontracts. The Contractor or subcontractor shall insert in any subcontracts the clauses contained in paragraph (a)(1) through (10) of this contract and such other clauses as the Federal Aviation Administration may by appropriate instructions require, and also a clause requiring the subcontractors to include these clauses in any lower tier subcontracts. The prime Contractor shall be responsible for the compliance by an subcontractor or lower tier subcontractor with all the contract clauses in 29 CFR 5.5.

(7) Contract determination: debarment. A breach of these contract clauses paragraphs (a)(1) through (10) and the 2nd clause (b)(1) through (5) below may be grounds for termination of the contract and for debarment as a Contractor and a subcontractor as provided in 29 CFR 5.12.

(8) Compliance with Davis-Bacon and Related Act requirements. All rulings and interpretations of the Davis-Bacon and Related Acts contained in 29 CFR Parts 1, 3, and 5 are herein incorporated by referenced in this contract.

(9) Disputes concerning labor standards. Disputes arising out of the labor standards provisions of this contract shall not be subject to the general disputes clause of this contract. Such disputes shall be resolved in accordance with the procedures of the Department of Labor set forth in 29 CFR Parts 5, 6, and 7. Disputes within the meaning of this clause include disputes between the Contractor (or any of its subcontractors) and the contracting agency, the U.S. Department of Labor, or the employees or their representatives.

(10) Certification of Eligibility.

(i) By entering into this contract, the Contractor certifies that neither it (nor he or she) nor any person or firm who has an interest in the Contractor's firm is a person or firm ineligible to be awarded Government contracts by virtue of section 3(a) of the Davis-Bacon Act or 29 CFR 5.12(a)(1).

(ii) No part of this contract shall be subcontracted to any person or firm ineligible for award of a Government contract by virtue of section 3(a) of the Davis-Bacon Act or 29 CFR 5.12(a)(1).

(iii) The penalty for making false statements is prescribed in the U.S. Criminal Code, 18 U.S.C. 1001.

(b) Contract Work Hours and Safety Standards Act. The Agency Head shall cause or require the contracting officer to insert the following clauses set forth in paragraphs (b)(1), (2), (3), (4) and (5) of this section in full in AIP construction contracts in excess of \$2,000. These clauses shall be inserted in addition to the clauses required by paragraph 5.5(a) or paragraph 4.6 of Part 4 of this title. As used in this paragraph, the terms "laborers" and "mechanics" include watchmen and guards.

(1) Overtime requirements: No Contractor or subcontractor contracting for any part of the contract work which may require or involve the employment of laborers, mechanics, watchmen or guards (including apprentices and trainees described in paragraphs 5 and 6 above) shall require or permit any laborer, mechanic, watchman or guard in any workweek in which he/she is employed on such work, to work in excess of 40 hours in such workweek unless such laborer, mechanic, watchman or guard receives compensation at a rate not less than one and one-half times his/her basic rate of pay for all hours worked in excess of 40 hours in such workweek.

(2) Violations: Liability for Unpaid Wages; Liquidated Damages: In the event of any violation of the clause set forth in subparagraph (1) of this paragraph, the Contractor and any subcontractor responsible therefore shall be liable to any affected employee for his/her unpaid wages. In addition, such Contractor and subcontractor shall be liable to the United States (in case of work done under contract for the District of Columbia or a territory, to such District or to such territory), for liquidated damages. Such liquidated damages shall be computed with respect to each individual laborer, mechanic, watchman or guard employed in violation of the clause set forth in subparagraph (1) of this paragraph, in the sum of \$10.00 for each calendar day on which such employee was required or permitted to work in excess of the standard workweek of 40 hours without payment of the overtime wages required by the clause set forth in subparagraph (1) of this paragraph.

(3) Withholding for unpaid wages and liquidated damages. The (write in the name of the Federal agency or the loan or grant recipient) shall upon its own action or upon written request of an authorized representative of the Department of Labor withhold or cause to be withheld, from any moneys payable on account of work performed by the Contractor or subcontractor under any such contract or any other Federal contract with the same prime Contractor, or any other Federally-assisted contract subject to the Contract Work Hours and Safety Standards Act, which is held by the same prime Contractor, such sums as may be determined to be necessary to satisfy any liabilities of such Contractor or subcontractor for unpaid wages and liquidated damages as provided in the clause set forth in subparagraph (2) of this paragraph.

(4) Subcontracts. The Contractor or subcontractor shall insert in any subcontracts the clauses set forth in subparagraph (1) through (4) of this paragraph and also a clause requiring the subcontractors to include these clauses in any lower tier subcontracts. The prime Contractor shall be responsible for compliance by any subcontractor or lower tier subcontractor with the clauses set forth in subparagraphs (1) through (4) of this paragraph.

(5) Working Conditions. No Contractor or subcontractor may require any laborer or mechanic employed in the performance of any contract to work in surroundings or under working conditions that are unsanitary, hazardous, or dangerous to his health or safety as determined under construction safety and health standards (29 CFR 1926) issued by Department of Labor.

(c) In addition to the clauses contained in paragraph (b), in any contract subject only to the Contract Work Hours and Safety Standards Act and not to any of the other statutes cited in paragraph 5.1, the Agency Head shall cause or require the contracting officer to insert a clause requiring that the Contractor or subcontractor shall maintain payrolls and basic payroll records during the course of the work and shall preserve them for a period of three years from the completion of the contract for all laborers and mechanics, including guards and watchmen, working on the contract. Such records shall contain the name and address of each such employee, social security number, correct classifications, hourly rates of wages paid, daily and weekly number of hours worked, deductions made, and actual wages paid. Further, the Agency Head shall cause or require the contracting officer to insert in any such contract a clause providing that the records to be maintained under this paragraph shall be made available by the Contractor or subcontractor for inspection, copying, or transcription by authorized representatives of the (write the name of agency) and the Department of Labor, and the Contractor or subcontractor will permit such representatives to interview employees during working hours on the job. (Approved by the Office of Management and Budget under OMB control numbers 1215-0140 and 1215-0017).

FEDERAL REGULATIONS VOL. 40, #74,
WEDNESDAY, APRIL 16, 1975, PAGE 17124,
ADMINISTRATION OF THE CLEAR AIR ACT
& WATER POLLUTION CONTROL ACT
(with respect to Federal Grants)

In connection with the administration of the Clean Air Act and the Water Pollution Control Act with respect to Federal Grants, specific requirements have been imposed of any contract which is not exempt under the provisions of 40 CFR 15.5.

(1) Any facility listed on the EPA List of Violating Facilities pursuant to Paragraph 15.20 of 40 CFR as of the date of the contract award will not be utilized in the performance of any non-exempt contract or subcontract.

(2) The Contractor shall comply with all the requirements of Section 114 of the Clean Air Act, as amended, 42 USC 1857 et seq. and Section 308 of the Federal Water Pollution Control Act, as amended, 33 USC 1251 et seq. relating to inspection, monitoring, entry, reports and information, as well as all other requirements specified in Section 114 and Section 308 of the Air Act and Water Act, respectively, and all regulations and guidelines issued thereunder after the award of the contract.

(3) Prompt notification shall be required prior to contract award to the awarding official by the Contractor who will receive the award of the receipt of any communication from the Director, Office of Federal Activities, U.S. Environmental Protection Agency, indicating that a facility to be utilized for the contract is under consideration to be listed on the EPA List of Violating Facilities.

(4) The Contractor shall include or cause to be included the criteria and requirements in paragraphs 1 through 4 in any non-exempt subcontract and will take such action as the Government may direct as a means of enforcing such provisions.

Attachment No. 1

During the performance of the contract, the Contractor agrees as follows:

- (1) The Contractor will not discriminate against any employee or applicant for employment because of race, color, religion, sex or national origin. The Contractor will take affirmative action to ensure that applicants are employed, and that employees are treated during employment without regard to their race, color, religion, sex or national origin. Such action shall include, but not be limited to the following: Employment, upgrading, demotion or transfer, recruitment or recruitment advertising, layoff or termination, rates of pay or other forms of compensation, and selection for training including apprenticeship. The Contractor agrees to post in conspicuous places, available to employees and applicants for employment, notices to be provided setting forth the provisions of this nondiscrimination clause.
- (2) The Contractor will, in all solicitations or advertisements for employees placed by or on the behalf of the Contractor, state that all qualified applicants will receive consideration for employment without regard to race, color, religion, sex or national origin.
- (3) The Contractor will send to each labor union or representative of workers with which he has a collective bargaining agreement or other contract or understanding, a notice to be provided advising the said labor union or worker's representatives of the Contractor's commitments under this section, and shall post copies of the notice in conspicuous places available to employees and applicants for employment.
- (4) The Contractor will comply with all provisions of Executive Order 11246 of September 24, 1965, and of the rules, regulations, and relevant orders of the Secretary of Labor.
- (5) The Contractor will furnish all information and reports required by Executive Order 11246 of September 24, 1965, and by rules, regulations and orders of the Secretary of Labor, or pursuant thereto, and will permit access to his books, records, and accounts by the administering agency and the Secretary of Labor for purposes of investigation to ascertain compliance with such rules, regulations, and orders.
- (6) In the event of the Contractor's noncompliance with the nondiscrimination clauses of this contract or with any of the said rules, regulations, or orders, this contract may be canceled, terminated, or suspended in whole or in part and the Contractor may be declared ineligible for further government contracts or federally assisted construction contracts in accordance with procedures authorized in Executive Order 11246 of 24 September 1965, and such other sanctions may be imposed and remedies invoked as provided in Executive Order 11246 of 24 September 1965, or by rule, regulation or order of the Secretary of Labor, or as otherwise provided by law.
- (7) The Contractor will include the portion of the sentence immediately preceding paragraph (1) and the provisions of paragraphs (1) through (7) in every subcontract or purchase order unless exempted by rules, regulations, or orders of the Secretary of Labor issued pursuant to Section 204 of Executive Order 11246 of 24 September 1965, so that such provisions will be binding upon each subcontractor or vendor. The Contractor will take such action with respect to any subcontract or purchase order as the administering agency may direct as means of enforcing such provisions, including sanctions for noncompliance; provided, however, that in the event a Contractor becomes involved in, or is threatened with, litigation with a subcontractor or vendor as a result of such direction by the administering agency, the Contractor may request the United States to enter into such litigation to protect the interests of the United States.

ATTACHMENT NO. 2

EACH PRIME CONTRACTOR SHALL INSERT IN EACH SUBCONTRACT THE CERTIFICATION IN APPENDIX B, AND FURTHER, SHALL REQUIRE ITS INCLUSION IN ANY LOWER TIER SUBCONTRACT, PURCHASE ORDER, OR TRANSACTION THAT MAY IN TURN BE MADE.

- Appendix B of 49 CFR Part 29 -

This certification applies to subcontractors, material suppliers, vendors and other lower tier participants.

Appendix B--Certification Regarding Debarment, Suspension, Ineligibility and Voluntary Exclusion--Lower Tier Covered Transactions

Instructions for Certification

1. By signing and submitting this proposal, the prospective lower tier participant is providing the certification set out below.

2. The certification in this clause is a material representation of fact upon which reliance was placed when this transaction was entered into. If it is later determined that the prospective lower tier participant knowingly rendered an erroneous certification, in addition to other remedies available to the Federal Government, the department or agency with which this transaction originated may pursue available remedies, including suspension and/or debarment.

3. The prospective lower tier participant shall provide immediate written notice to the person to which this proposal is submitted if at any time the prospective lower tier participant learns that its certification was erroneous when submitted or has become erroneous by reason of changed circumstances.

4. The terms "covered transaction," "debarred," "suspended," "ineligible," "lower tier covered transaction," "participant," "person," "primary covered transaction," "principal," "proposal," and "voluntarily excluded," as used in this clause sections of rules implementing Executive Order 12549. You may contact the person to which this proposal is submitted for assistance in obtaining a copy of those regulations.

5. The prospective lower tier participant agrees by submitting this proposal that, should the proposed covered transaction be entered into, it shall not knowingly enter into any lower tier covered transaction with a person who is debarred, suspended, declared ineligible, or voluntarily excluded from participation in this covered transaction, unless authorized by the department or agency with which this transaction originated.

6. The prospective lower tier participant further agrees by submitting this proposal that it will include this clause titled "Certification Regarding Debarment, Suspension, Ineligibility and Voluntary Exclusion--Lower Tier Covered Transaction," without modification, in all lower tier covered transactions and in all solicitations for lower tier covered transactions.

7. A participant in a covered transaction may rely upon a certification of a prospective participant in a lower tier covered transaction that it is not debarred, suspended, ineligible, or voluntarily excluded from the covered transaction, unless it knows that the certification is erroneous. A participant may decide the method and frequency by which it determines the eligibility of its principals. Each participant may, but is not required to, check the Nonprocurement List.

8. Nothing contained in the foregoing shall be construed to require establishment of a system of records in order to render in good faith the certification required by this clause. The knowledge and information of a participant is not required to exceed that which is normally possessed by a prudent person in the ordinary course of business dealings.

9. Except for transactions authorized under paragraph 5 of these instructions, if a participant in a covered transaction knowingly enters into a lower tier covered transaction with a person who is suspended, debarred, ineligible, or voluntarily excluded from participation in this transaction, in addition to other remedies available to the Federal Government, the department or agency with which this transaction originated may pursue available remedies, including suspension and/or debarment.

Certification Regarding Debarment, Suspension, Ineligibility and Voluntary Exclusion--Lower Tier Covered Transactions

(1) The prospective lower tier participant certifies, by submission of this proposal, that neither it nor its principals is presently debarred, suspended, proposed for debarment, declared ineligible, or voluntarily excluded from participation in this transaction by any Federal department or agency.

(2) Where the prospective lower tier participant is unable to certify to any of the statements in this certification, such prospective participant shall attach an explanation to this proposal.

STATE REQUIRED CONTRACT PROVISIONS
ALL FEDERAL-AID CONSTRUCTION CONTRACTS

Effective February 1, 1969
Revised January 2, 1973

The following provisions are State of Illinois requirements and are in addition to the Federal requirements.

"EQUAL EMPLOYMENT OPPORTUNITY"

In the event of the Contractor's noncompliance with any provisions of this Equal Employment Opportunity Clause, the Illinois Fair Employment Practices Act or the Fair Employment Practices Commission's Rules and Regulations for Public Contracts, the Contractor may be declared nonresponsible and therefore ineligible for future contracts or subcontracts with the State of Illinois or any of its political subdivisions or municipal corporations, and the contract may be canceled or avoided in whole or in part, and such other sanctions or penalties may be imposed or remedies invoked as provided by statute or regulation.

During the performance of this contract, the Contractor agrees as follows:

- (1) That it will not discriminate against any employee or applicant for employment because of race, color, religion, sex, national origin or ancestry; and further that it will examine all job classifications to determine if minority persons or women are underutilized and will take appropriate affirmative action to rectify any such underutilization.
- (2) That, if it hires additional employees in order to perform this contract or any portion hereof, it will determine the availability (in accordance with the Commission's Rules and Regulations for Public Contracts) of minorities and women in the area(s) from which it may reasonably recruit and it will hire for each job classification for which employees are hired in such a way that minorities and women are not underutilized.
- (3) That, in all solicitations or advertisements for employees placed by it or on its behalf, it will state that all applicants will be afforded equal opportunity without discrimination because of race, color, religion, sex, national origin or ancestry.
- (4) That it will send to each labor organization or representative of workers with which it has or is bound by a collective bargaining or other agreement or understanding, a notice advising such labor organization or representative of the Contractor's obligations under the Illinois Fair Employment Practices Act and the Commission's Rules and Regulations for Public Contracts. If any such labor organization or representative fails or refuses to cooperate with the Contractor in its efforts to comply with such Act and Rules and Regulations, the Contractor will promptly so notify the Illinois Fair Employment Practices Commission and the contracting agency and will recruit employees from other sources when necessary to fulfill its obligations thereunder.
- (5) That it will submit reports as required by the Illinois Fair Employment Practices Commission's Rules and Regulations for Public Contracts, furnish all relevant information as may from time to time be requested by the Commission or the contracting agency, and in all respects comply with the Illinois Fair Employment Practices Act and the Commission's Rules and Regulations for Public Contracts.
- (6) That it will permit access to all relevant books, records, accounts and work sites by personnel of the contracting agency and the Illinois Fair Employment Practices Commission for purposes of investigation to ascertain compliance with the Illinois Fair Employment Practices Act and the Commission's Rules and Regulations for Public Contracts.
- (7) That it will include verbatim or by reference the provisions of paragraphs 1 through 7 of this clause in every performance subcontract as defined in Section 2.10(b) of the Commission's Rules and Regulations for Public Contracts so that such provisions will be binding upon every subcontractor; and that it will also so include the provisions or paragraphs 1, 5, 6 and 7 in every supply subcontract as defined in Section 2.10(a) of the Commission's Rules and Regulations for Public Contracts so that such provisions will be binding upon every such subcontractor. In the same manner as with other provisions of this contract, the Contractor will be liable for compliance with applicable provisions of this clause by all its subcontractors; and further it will promptly notify the contracting agency and the Illinois Fair Employment Practices Commission in the event any subcontractor fails or refuses to comply therewith. In addition, no Contractor will utilize any subcontractor declared by the Commission to be nonresponsible and therefore ineligible for contracts or subcontracts with the State of Illinois or any of its political subdivisions or municipal corporations.

CONSTRUCTION CONTRACT PROCUREMENT POLICIES

TABLE OF CONTENTS

SECTION 1

Proposal Requirements and Conditions

SUB-SECTION

1-01 ADVERTISEMENT (Notice to Bidders).....	44
1-02 PREQUALIFICATION OF BIDDERS.....	44
1-03 CONTENTS OF PROPOSAL FORMS.....	45
1-04 ISSUANCE OF PROPOSAL FORMS.....	45
1-05 INTERPRETATION OF QUANTITIES IN BID SCHEDULE.....	45
1-06 EXAMINATION OF PLANS, SPECIFICATIONS, AND SITE.....	45
1-07 PREPARATION OF THE PROPOSAL.....	46
1-08 REJECTION OF PROPOSALS.....	46
1-09 PROPOSAL GUARANTY.....	46
1-10 DELIVERY OF PROPOSALS.....	46
1-11 WITHDRAWAL OF PROPOSALS.....	46
1-12 PUBLIC OPENING OF PROPOSALS.....	46
1-13 DISQUALIFICATION OF BIDDERS.....	47
1-14 WORKER'S COMPENSATION INSURANCE.....	47

SECTION 2

Award and Execution of Contract

SUB-SECTION

2-01 CONSIDERATION OF PROPOSALS.....	47
2-02 AWARD OF CONTRACT.....	47
2-03 CANCELLATION OF AWARD.....	48
2-04 RETURN OF PROPOSAL GUARANTY.....	48
2-05 REQUIREMENT OF PERFORMANCE AND PAYMENT BONDS.....	48
2-06 EXECUTION OF CONTRACT.....	48
2-07 APPROVAL OF CONTRACT.....	48
2-08 FAILURE TO EXECUTE CONTRACT.....	48

SECTION 1

PROPOSAL REQUIREMENTS AND CONDITIONS

1-01 ADVERTISEMENT (Notice to Bidders). The State of Illinois shall publish the advertisement at such places and at such times as are required by local law or ordinances. The published advertisement shall state the time and place for submitting sealed proposals; a description of the proposed work; instructions to bidders as to obtaining proposal forms, plans, and specifications; proposal guaranty required; and the Owner's right to reject any and all bids.

For Federally assisted contracts the advertisement shall conform to the requirements of local laws and ordinances pertaining to letting of contracts and, in addition, shall conform to the requirements of the appropriate parts of the Federal Aviation Regulations applicable to the particular contract being advertised.

1-02 PREQUALIFICATION OF BIDDERS.

- (a) When the awarding authority is the State of Illinois, each prospective bidder, prior to being considered for issuance of any proposal forms will be required to file, on forms furnished by the Department, an experience questionnaire and a confidential financial statement in accordance with the Department's Instructions for Prequalification of Contractors. The Statement shall include a complete report of the prospective bidder's financial resources and liabilities, equipment, past record and personnel, and must be submitted at least thirty (30) days prior to the scheduled opening of bids in which the Contractor is interested.

After the Department has analyzed the submitted "Contractor's Statement of Experience and Financial Condition" and related information and has determined appropriate ratings, the Department will issue to the Contractor a "Certificate of Eligibility". The Certificate will permit the Contractor to obtain proposal forms and plans for any Department of Transportation letting on work which is within the limits of the Contractor's potential as indicated on his "Certificate of Eligibility", subject to any limitations due to present work under contract or pending award as determined from the Contractor's submitted "Affidavit of Availability". Bidders intending to consistently submit proposals shall submit a "Contractor's Statement of Experience and Financial Condition" at least once a year. However, prequalification may be changed during that period upon the submission of additional favorable reports or upon reports of unsatisfactory performance.

Before a proposal is issued, the prospective bidder will be required to furnish an "Affidavit of Availability" indicating the location and amount of all uncompleted work under contract, or pending award, either as principal or subcontractor, as well as a listing of all subcontractors and value of work sublet to others. The prospective bidder may be requested to file a statement showing the amount and condition of equipment which will be available.

Before an award is made, the bidder may be required to furnish an outline of his plans for conducting the work.

- (b) When the awarding authority for contract construction work is the County Board of a county; the Council, the City Council, or the President and Board of Trustees of a city, village or town, each prospective bidder, in evidence of his competence, shall furnish the awarding authority as a prerequisite to the release of proposal forms by the awarding authority, a certified or photostatic copy of a "Certificate of Eligibility" issued by the Department of Transportation, in accordance with Section 1-02(a).

The two low bidders must file within 24 hours after the letting a sworn affidavit, in triplicate, showing all uncompleted contracts awarded to them and all low bids pending award for Federal, State, County, Municipal and private work, using the blank form made available for this affidavit. One copy shall be filed with the awarding authority and two copies with the District Highway Office.

1-03 CONTENTS OF PROPOSAL FORMS. Upon request, the Department will furnish the prequalified bidders a proposal form. This form will state the location and description of the contemplated construction and will show the estimate of the various quantities and kinds of work to be performed or materials to be furnished, and will have a schedule of items for which unit bid prices are invited. The proposal form will state the time in which work must be completed, the amount of the proposal guaranty, labor requirements, and date, time and place of the opening of proposals. The form will also include any special provisions or requirements which vary from or are not contained in these specifications.

All papers bound with or attached to the proposal form are considered a part thereof and must not be detached or altered when the proposal is submitted. Any addenda officially issued by the Department, will be considered a part of the proposal whether attached or not.

For Federally assisted contracts, the proposal shall conform to the requirements of local laws and ordinances pertaining to letting of contracts and, in addition, shall conform to the requirements of the appropriate parts of the Federal Aviation Regulations pertaining to the particular contract being let.

1-04 ISSUANCE OF PROPOSAL FORMS. The Department shall refuse to issue a proposal form for any of the following reasons:

- (a) Lack of competency and adequate machinery, plant and other equipment, as revealed by the financial statement and experience questionnaires required under Section 1-02(a).
- (b) Uncompleted work which, in the judgment of the Department, might hinder or prevent the prompt completion of additional work if awarded.
- (c) False information provided on a bidder's "Affidavit of Availability".
- (d) Failure to pay, or satisfactorily settle, all bills due for labor and material on former contracts in force at the time of issuance of proposal forms.
- (e) Failure to comply with any prequalification regulations of the Department.
- (f) Default under previous contracts.
- (g) Unsatisfactory performance record as shown by past work for the Department, judged from the standpoint of workmanship and progress.
- (h) When the Contractor is suspended from eligibility to bid at a public letting where the contract is awarded by, or require approval of, the Department.
- (i) When any agent, servant, or employee of the prospective bidder currently serves as a member, employee, or agent of a governmental body that is financially involved in the proposed work.
- (j) When any agent, servant, or employee of the prospective bidder has participated in the preparation of plans or specifications for the proposed work.

1-05 INTERPRETATION OF QUANTITIES IN BID SCHEDULE. An estimate of quantities of work to be done and materials to be furnished under these specifications is given in the proposal. It is the result of careful calculations and is believed to be correct. It is given only as a basis for comparison of proposals and the award of the contract. The Owner does not expressly or by implication agree that the actual quantities involved will correspond exactly therewith; nor shall the bidder plead misunderstanding or deception because of such estimates of quantities, or of the character, location, or other conditions pertaining to the work. Payment to the Contractor will be made only for the actual quantities of work performed or materials furnished in accordance with the plans and specifications. It is understood that the quantities may be increased or decreased as provided in the subsection titled ALTERATION OF WORK AND QUANTITIES of Section 20 of the Illinois Standard Specifications for Construction of Airports without in any way invalidating the unit bid prices.

1-06 EXAMINATION OF PLANS, SPECIFICATIONS, AND SITE. The bidder is expected to carefully examine the site of the proposed work, the proposal, plans, specifications, and contract forms. He shall satisfy himself as to the character, quality, and quantities of work to be performed, materials to be furnished, and as to the requirements of the proposed contract. The submission of a proposal shall be prima facie evidence that the bidder has made such examination and is satisfied as to the conditions to be encountered in performing the work and as to the requirements of the proposed contract, plans, and specifications.

Boring logs, underground utilities and other records of subsurface investigations and tests are available for inspection of bidders. It is understood and agreed that such subsurface information, whether included in the plans, specifications, or otherwise made available to the bidder, was obtained and is intended for the Owner's design and estimating purposes only. Such information has been made available for the convenience of all bidders. It is further understood and agreed that each bidder is solely responsible for all assumptions, deductions, or conclusions which he may make or obtain from his examination of the boring logs and other records of subsurface investigations and tests that are furnished by the Owner.

1-07 PREPARATION OF THE PROPOSAL. The bidder shall submit his proposal on the form furnished by the Department. The proposal shall be executed properly, and bids shall be made for all items indicated in the proposal form, except that when alternate bids are asked, a bid on more than one alternate for each item is not required, unless otherwise provided. The bidder shall indicate, in figures, a unit price for each of the separate items called for in the proposal; he shall show the products of the respective quantities and unit prices in the column provided for that purpose, and the gross sum shown in the place indicated in the proposal shall be the summation of said products. All writing shall be with ink or typewriter, except the signature of the bidder which shall be written with ink.

If the proposal is made by an individual, his name and business address shall be shown. If made by a firm or partnership, the name and business address of each member of the firm or partnership shall be shown. If made by a corporation, the proposal shall show the names, titles, and business address of the president, secretary, and treasurer, and the seal of the corporation shall be affixed and attested by the secretary.

The proposal shall be issued to a prequalified bidder in the same name and style as the financial statement used for prequalification and shall be submitted in like manner.

1-08 REJECTION OF PROPOSALS. The Department reserves the right to reject proposals for any of the conditions in Article 1-04 or for any of the following reasons:

- (a) More than one proposal for the same work from an individual, firm, partnership, or corporation under the same or different names.
- (b) Evidence of collusion among bidders.
- (c) Unbalanced proposals in which the prices for some items are obviously out of proportion to the prices for other items.
- (d) If the proposal does not contain a unit price for each pay item listed except in the case of authorized alternate pay items or lump sum pay items.
- (e) If the proposal is other than that furnished by the Department; or if the form is altered or any part thereof is detached.
- (f) If there are omissions, erasures, alterations, unauthorized additions, conditional or alternate bids, or irregularities of any kind which may tend to make the proposal incomplete, indefinite, or ambiguous as to its meaning.
- (g) If the bidder adds any provisions reserving the right to accept or reject an award, or to enter into a contract pursuant to an award.
- (h) If the proposal is not accompanied by the proper proposal guaranty.
- (i) If the proposal is prepared with other than ink or typewriter.
- (j) If the proposal is submitted in any other name other than that to whom it was issued by the Department.

1-09 PROPOSAL GUARANTY. Each Proposal shall be accompanied by either a bid bond on the Department of Transportation, Division of Aeronautics form contained in the proposal, executed by a corporate surety company satisfactory to the Department or by a bank cashier's check or a properly certified check for not less than 5 percent of the amount bid.

Bank cashier's checks, or properly certified checks accompanying proposals shall be made payable to the Treasurer, State of Illinois.

1-10 DELIVERY OF PROPOSALS. Each proposal should be submitted in a special envelope furnished by the Department. The blank spaces on the envelope shall be filled in correctly to clearly indicate its contents. When an envelope other than the special one furnished by the Department is used, it shall be of the same general size and shape and be similarly marked to clearly indicate its contents. When sent by mail, the sealed proposal shall be addressed to the Department at the address and in care of the official in whose office the bids are to be received. All proposals shall be filed prior to the time and place specified in the Notice to Bidders. Proposals received after the time for opening of bids will be returned to the bidder unopened.

1-11 WITHDRAWAL OF PROPOSALS. Permission will be given a bidder to withdraw a proposal if he makes his request in writing or by telegram before the time for opening proposals. If a proposal is withdrawn, the bidder will not be permitted to resubmit this proposal at the same letting. With the approval of the Engineer, a bidder may withdraw a proposal and substitute a new proposal prior to the time of opening bids.

1-12 PUBLIC OPENING OF PROPOSALS. Proposals will be opened and read publicly at the time and place specified in the Notice to Bidders. Bidders, their authorized agents, and other interested parties are invited to be present.

1-13 DISQUALIFICATION OF BIDDERS. A bidder shall be considered disqualified for any of the following reasons:

- (a) Submitting more than one proposal from the same partnership, firm, or corporation under the same or different name.
- (b) Evidence of collusion among bidders. Bidders participating in such collusion shall be disqualified as bidders for any future work of the Owner.
- (c) If the bidder is considered to be in "default" for any reason specified in the Subsection 1-04 titled ISSUANCE OF PROPOSAL FORMS of this section.

1-14 WORKER'S COMPENSATION INSURANCE. Prior to the approval of his contract by the Division, the Contractor shall furnish to the Division certificates of insurance covering Worker's Compensation, or satisfactory evidence that this liability is otherwise taken care of in accordance with Section 4.(a) of the "Worker's Compensation Act of the State of Illinois" as amended.

SECTION 2

AWARD AND EXECUTION OF CONTRACT

2-01 CONSIDERATION OF PROPOSALS. After the proposals are publicly opened and read, they will be compared on the basis of the summation of the products obtained by multiplying the estimated quantities shown in the proposal by the unit bid prices. In the event of a discrepancy between unit bid prices and extensions, the unit bid price shall govern.

Until the award of a contract is made, the Owner reserves the right to reject a bidder's proposal for any of the following reasons:

- (a) If the proposal is irregular as specified in the subsection titled REJECTION OF PROPOSALS of Section 1.
- (b) If the bidder is disqualified for any of the reasons specified in the subsection titled DISQUALIFICATION OF BIDDERS of Section 1.

In addition, until the award of a contract is made, the Owner reserves the right to reject any or all proposals; waive technicalities, if such waiver is in the best interest of the Owner and is in conformance with applicable State and Local laws or regulations pertaining to the letting of construction contracts; advertise for new proposals; or proceed with the work otherwise.

2-02 AWARD OF CONTRACT. The award of contract will be made within 75 calendar days after the opening of proposals to the lowest responsible and qualified bidder whose proposal complies with all the requirements prescribed. The successful bidder will be notified by letter, that his bid has been accepted, and that he has been awarded the contract.

If a contract is not awarded within 75 days after the opening of proposals, a bidder may file a written request with the Division for the withdrawal of his bid and the Division will permit such withdrawal.

The award period for this project is 75 days and expires on May 20, 2009. At that point, the contractor may request, in writing, an award extension of 16 days, which will expire on June 5, 2009. At this point, the contractor may request a second and final award extension, in writing, of 117 days which will expire on September 30, 2009. There is no guarantee that this project will be awarded. Written request for extensions should be mailed to:

**IDOT Division of Aeronautics
Abraham Lincoln Capital Airport
1 Langhorne Bond Drive
Springfield, IL 62707-8415
Attn: Contracts Section**

For Federally assisted contracts, unless otherwise specified in this subsection, no award shall be made until the FAA has concurred in the Owner's recommendation to make such award and has approved the Owner's proposal contract to the extent that such concurrence and approval are required by Federal Regulations.

2-03 CANCELLATION OF AWARD. The Division reserves the right to cancel the award without liability to the bidder at any time before a contract has been fully executed by all parties and is approved by the Owner in accordance with the subsection titled APPROVAL OF CONTRACT of this section. The Division at the time of cancellation will return the proposal guaranty.

2-04 RETURN OF PROPOSAL GUARANTY. The proposal guaranties of all except the two lowest bidders will be returned promptly after the proposals have been checked, tabulated, and the relation of the proposals established. Proposal guaranties of the two lowest bidders will be returned as soon as the Construction Contract, Performance Bonds, and Payment Bonds of the successful bidder have been properly executed and approved.

If any other form of proposal guaranty is used, other than a bid bond, a bid bond may be substituted at the Contractor's option.

2-05 REQUIREMENT OF PERFORMANCE AND PAYMENT BONDS. The successful bidder for a contract, at the time of the execution of the contract, shall deposit with the Division separate performance and payment bonds each for the full amount of the contract. The form of the bonds shall be that furnished by the Division, and the sureties shall be acceptable to the Division.

2-06 EXECUTION OF CONTRACT. The successful bidder shall sign (execute) the Contract and shall return the signed Contract to the Owner (Sponsor) for signature (execution) and subsequently return all copies to the Division. The fully executed surety bonds specified in the subsection title REQUIREMENTS OF PERFORMANCE AND PAYMENT BONDS of this section will be forwarded to the Division within 15 days of the date mailed or otherwise delivered to the successful bidder. If the Contract and Bonds are mailed, special handling is recommended.

If the bidder to whom award is to be made is a corporation organized under the laws of a State other than Illinois, the bidder shall furnish the Division a copy of the corporation's certificate of authority to do business in the State of Illinois with the return of the executed contract and bond. Failure to furnish such evidence of a certificate of authority within the time required will be considered as just cause for the annulment of the award and the forfeiture of the proposal guaranty to the State, not as a penalty, but in payment of liquidated damages sustained as a result of such failure.

2-07 APPROVAL OF CONTRACT. Upon receipt of the contract and bonds that have been executed by the successful bidder, the Owner shall complete the execution of the contract in accordance with local laws or ordinances, and return the contract to the Division for approval and execution by the Division. Delivery of the fully executed contract to the Contractor shall constitute the Department's approval to be bound by the successful bidder's proposal and the terms of the contract.

2-08 FAILURE TO EXECUTE CONTRACT. If the contract is not executed by the Division within 15 days following receipt from the bidder of the properly executed contracts and bonds, the bidder shall have the right to withdraw his bid without penalty.

Failure of the successful bidder to execute the contract and file acceptable bonds within 15 days after the contract has been mailed to him shall be just cause for the cancellation of the award and the forfeiture of the proposal guaranty which shall become the property of the State, not as a penalty, but as liquidation of damages sustained.

ILLINOIS DEPARTMENT OF TRANSPORTATION

DIVISION OF AERONAUTICS

The requirements of the following provisions written for Federally-assisted construction contracts, including all goals and timetables and affirmative action steps, shall also apply to all State-funded construction contracts awarded by the Illinois Department of Transportation.

NOTICE OF REQUIREMENT FOR AFFIRMATIVE ACTION TO ENSURE EQUAL EMPLOYMENT OPPORTUNITY (EXECUTIVE ORDER 11246)

1. The Offeror's or Bidder's attention is called to the "Equal Opportunity Clause" and the "Standard Federal Equal Employment Opportunity Construction Contract Specifications" set forth herein.

2. The goals and timetables for minority and female participation, expressed in percentage terms for the Contractor's aggregate workforce in each trade on all construction work in the covered area, are as follows:

APPENDIX A

The following goal for female utilization in each construction craft and trade shall apply to all Contractors holding Federal and federally assisted construction contracts and subcontracts in excess of \$10,000. The goal is applicable to the Contractor's total on-site construction workforce, regardless of whether or not part of that workforce is performing work on a Federal, federally assisted or nonfederally related construction contract or subcontract.

AREA COVERED (STATEWIDE)

Goals for Women apply nationwide.

GOAL

	Goal (percent)
Female Utilization.....	... 6.9

APPENDIX B

Until further notice, the following goals for minority utilization in each construction craft and trade shall apply to all Contractors holding Federal and federally-assisted construction contracts and subcontracts in excess of \$10,000. to be performed in the respective geographical areas. The goals are applicable to the Contractor's total on-site construction workforce, regardless of whether or not part of that workforce is performing work on a Federal, federally-assisted or nonfederally related construction contract or subcontract.

<u>Economic Area</u>	<u>Goal (percent)</u>
056 Paducah, KY:	
Non-SMSA Counties -	5.2
IL - Hardin, Massac, Pope	
KY - Ballard, Caldwell, Calloway, Carlisle, Crittenden,	
Fulton, Graves, Hickman, Livingston, Lyon, McCracken, Marshall	

Revised 08-31-83

<u>Economic Area</u>	<u>Goal (percent)</u>
080 Evansville, IN:	
Non-SMSA Counties -	3.5
IL - Edwards, Gallatin, Hamilton, Lawrence, Saline, Wabash, White	
IN - Dubois, Knox, Perry, Pike, Spencer	
KY - Hancock, Hopkins, McLean, Mublenberg, Ohio, Union, Webster	
081 Terre Haute, IN:	
Non-SMSA Counties -	2.5
IL - Clark, Crawford	
IN - Parke	
083 Chicago, IL:	
SMSA Counties:	19.6
1600 Chicago, IL -	
IL - Cook, DuPage, Kane, Lake, McHenry, Will	
3740 Kankakee, IL -	9.1
IL - Kankakee	
Non-SMSA Counties	18.4
IL - Bureau, DeKalb, Grundy, Iroquois, Kendall, LaSalle, Livingston, Putnam	
IN - Jasper, Laporte, Newton, Pulaski, Starke	
084 Champaign - Urbana, IL:	
SMSA Counties:	
1400 Champaign - Urbana - Rantoul, IL -	7.8
IL - Champaign	
Non-SMSA Counties -	4.8
IL - Coles, Cumberland, Douglas, Edgar, Ford, Piatt, Vermilion	
085 Springfield - Decatur, IL:	
SMSA Counties:	
2040 Decatur, IL -	7.6
IL - Macon	
7880 Springfield, IL -	4.5
IL - Mendard, Sangamon	
Non-SMSA Counties	4.0
IL - Cass, Christian, Dewitt, Logan, Morgan, Moultrie, Scott, Shelby	
086 Quincy, IL:	
Non-SMSA Counties	3.1
IL - Adams, Brown, Pike	
MO - Lewis, Marion, Pike, Ralls	
087 Peoria, IL:	
SMSA Counties:	
1040 Bloomington - Normal, IL -	2.5
IL - McLean	

Revised 08-31-83

APPENDIX B (CONTINUED)

<u>Economic Area</u>	<u>Goal (percent)</u>
6120 Peoria, IL - IL - Peoria, Tazewell, Woodford	4.4
Non-SMSA Counties - IL - Fulton, Knox, McDonough, Marshall, Mason, Schuyler, Stark, Warren	3.3
088 Rockford, IL: SMSA Counties: 6880 Rockford, IL - IL - Boone, Winnebago	6.3
Non-SMSA Counties - IL - Lee, Ogle, Stephenson	4.6
098 Dubuque, IA: Non-SMSA Counties - IL - JoDaviess IA - Atlamakee, Clayton, Delaware, Jackson, Winnesheik WI - Crawford, Grant, Lafayette	0.5
099 Davenport, Rock Island, Moline, IA - IL: SMSA Counties: 1960 Davenport, Rock Island, Moline, IA - IL - IL - Henry, Rock Island IA - Scott	4.6
Non-SMSA Counties - IL - Carroll, Hancock, Henderson, Mercer, Whiteside IA - Clinton, DesMoines, Henry, Lee, Louisa, Muscatine MO - Clark	3.4
107 St. Louis, MO: SMSA Counties: 7040 St. Louis, MO - IL - IL - Clinton, Madison, Monroe, St. Clair MO - Franklin, Jefferson, St. Charles, St. Louis, St. Louis City	14.7
Non-SMSA Counties - IL - Alexander, Bond, Calhoun, Clay, Effingham, Fayette, Franklin, Greene, Jackson, Jasper, Jefferson, Jersey, Johnson, Macoupin, Marion, Montgomery, Perry, Pulaski, Randolph, Richland, Union, Washington, Wayne, Williamson MO - Bollinger, Butler, Cape Girardeau, Carter, Crawford, Dent, Gasconade, Iron, Lincoln, Madison, Maries, Mississippi, Montgomery, Perry, Phelps, Reynolds, Ripley, St. Francois, St. Genevieve, Scott, Stoddard, Warren, Washington, Wayne	11.4

Revised 08-31-83

These goals are applicable to all the Contractor's construction work (whether or not it is Federal or federally assisted) performed in the covered area. If the Contractor performs construction work in a geographical area located outside of the covered area, it shall apply the goals established for such geographical area where the work is actually performed. With regard to this second area, the Contractor also is subject to the goals for both its federally involved and nonfederally involved construction.

The Contractor's compliance with Executive Order and the regulations in 41 CFR Part 60-4 shall be based on its implementation of the Equal Opportunity Clause, specific affirmative action obligations required by the provisions and specifications set forth in its federally assisted contracts, and its efforts to meet the goals established for the geographical area where the contract resulting from this solicitation is to be performed. The hours of minority and female employment and training must be substantially uniform throughout the length of the contract, and in each trade, and the Contractor shall make a good faith effort to employ minorities and women evenly on each of its projects. The transfer of minority or female employees or trainees from Contractor to Contractor or from project to project for the sole purpose of meeting the Contractor's goals shall be a violation of the contract, the Executive Order and the regulations in 41 CFR Part 60-4. Compliance with the goals will be measured against the total work hours performed.

3. The Illinois Division of Aeronautics will provide written notification to the Director of the Office of Federal Contract Compliance Programs within 10 working days of award of any construction contract and/or subcontract in excess of \$10,000 at any tier for construction work under the contract resulting from this solicitation. This notification will list the name, address and telephone number of the subcontractor; employer identification number; estimated dollar amount of the subcontract; estimated starting and completion dates of the subcontract; and the geographical area in which the contract is to be performed.

4. As used in this Notice, and in the contract resulting from this solicitation, the "covered area" is the entire State of Illinois for the goal set forth in APPENDIX A and the county or counties in which the work is located for the goals set forth in APPENDIX B.

STANDARD FEDERAL EQUAL EMPLOYMENT
OPPORTUNITY CONSTRUCTION CONTRACT
SPECIFICATIONS (EXECUTIVE ORDER 11246)

1. As used in these specifications:
 - a) "Covered area" means the geographical area described in the solicitation from which this contract resulted;
 - b) "Director" means Director, Office of Federal Contract Compliance Programs, United States Department of Labor, or any person to whom the Director delegates authority;
 - c) "Employer identification number" means the Federal Social Security number used on the Employer's Quarterly Federal Tax Return, U.S. Treasury Department Form 941;
 - d) "Minority" includes:
 - (i) Black (all persons having origins in any of the Black African racial groups not of Hispanic origin);
 - (ii) Hispanic (all persons of Mexican, Puerto Rican, Cuban, Central or South American or other Spanish Culture or origin, regardless of race);
 - (iii) Asian and Pacific Islander (all persons having origins in any of the original peoples of the Far East, Southeast Asia, the Indian Subcontinent, or the Pacific Islands); and
 - (iv) American Indian or Alaskan Native (all persons having origins in any of the original peoples of North America and maintaining identifiable tribal affiliations through membership and participation or community identification).
2. Whenever the Contractor, or any Subcontractor at any tier, subcontracts a portion of the work involving any construction trade, it shall physically include in each subcontract in excess of \$10,000. the provisions of these specifications and the Notice which contains the applicable goals for minority and female participation and which is set forth in the solicitations from which this contract resulted.

Revised 08-31-83

3. If the Contractor is participating (pursuant to 41 CFR 60-4.5) in a Hometown Plan approved by the U.S. Department of Labor in the covered area either individually or through an association, its affirmative action obligations on all work in the plan area (including goals and timetables) shall be in accordance with that Plan for those trades which have unions participating in the Plan. Contractors must be able to demonstrate their participation in and compliance with the provisions of any such Hometown Plan. Each Contractor or Subcontractor participating in an approved Plan is individually required to comply with its obligations under the EEO clause, and to make a good faith effort to achieve each goal under the Plan in each trade in which it has employees. The overall good faith performance by other Contractors or Subcontractors toward a goal in an approved Plan does not excuse any covered Contractor's or Subcontractor's failure to take good faith efforts to achieve the Plan goals and timetables.
4. The Contractor shall implement the specific affirmative action standards provided in paragraphs 7a through p of these specifications. The goals set forth in the solicitation from which this contract resulted are expressed as percentages of the total hours of employment and training of minority and female utilization the Contractor should reasonably be able to achieve in each construction trade in which it has employees in the covered area. Covered Construction Contractors performing construction work in geographical areas where they do not have a Federal or federally assisted construction contract shall apply the minority and female goals established for the geographical area where the work is being performed. Goals are published periodically in the Federal Register in notice form, and such notices may be obtained from any Office of Federal Contract Compliance Programs office or from Federal procurement contracting officers. The Contractor is expected to make substantially uniform progress toward its goals in each craft during the period specified.
5. Neither the provisions of any collective bargaining agreement, nor the failure by a union with whom the Contractor has a collective bargaining agreement, to refer either minorities or women shall excuse the Contractor's obligations under these specifications, Executive Order 11246, or the regulations promulgated pursuant thereto.
6. In order for the nonworking training hours of apprentices and trainees to be counted in meeting the goals, such apprentices and trainees must be employed by the Contractor during the training period, and the Contractor must have made a commitment to employ the apprentices and trainees at the completion of their training, subject to the availability of employment opportunities. Trainees must be trained pursuant to training programs approved by the U.S. Department of Labor.
7. The Contractor shall take specific affirmative actions to ensure equal employment opportunity. The evaluation of the Contractor's compliance with these specifications shall be based upon its effort to achieve maximum results from its actions. The Contractor shall document these efforts fully, and shall implement affirmative action steps at least as extensive as the following:
 - a) Ensure and maintain a working environment free of harassment, intimidation, and coercion at all sites, and in all facilities at which the Contractor's employees are assigned to work. The Contractor, where possible, will assign two or more women to each construction project. The Contractor shall specifically ensure that all foremen, superintendents, and other on-site supervisory personnel are aware of and carry out the Contractor's obligation to maintain such a working environment, with specific attention to minority or female individuals working as such sites or in such facilities.
 - b) Establish and maintain a current list of minority and female recruitment sources, provide written notification to minority and female recruitment sources and to community organizations when the Contractor or its unions have employment opportunities available, and maintain a record of the organizations' responses.
 - c) Maintain a current file of the names, addresses and telephone numbers of each minority and female off-the-street applicant and minority or female referral from a union, a recruitment source or community organization and of what action was taken with respect to each such individual. If such individual was sent to the union hiring hall for referral and was not referred back to the Contractor by the union or, if referred, not employed by the Contractor, this shall be documented in the file with the reason therefor, along with whatever additional actions the Contractors may have taken.

Revised 08-31-83

- d) Provide immediate written notification to the Director when the union or unions with which the Contractor has a collective bargaining agreement has not referred to the Contractor a minority person or woman sent by the Contractor, or when the Contractor has other information that the union referral process has impeded the Contractor's efforts to meet its obligations.
- e) Develop on-the-job training opportunities and/or participate in training programs for the area which expressly include minorities and women, including upgrading programs and apprenticeship and trainee programs relevant to the Contractor's employment needs, especially those programs funded or approved by the Department of Labor. The Contractor shall provide notice of these programs to the sources compiled under 7b above.
- f) Disseminate the Contractor's EEO policy by providing notice of the policy to unions and training programs and requesting their cooperation in assisting the Contractor in meeting its EEO obligations; by including it in any policy manual and collective bargaining agreements; by publicizing it in the company newspaper, annual report, etc.; by specific review of the policy with all management personnel and with all minority and female employees at least once a year; and by posting the company EEO policy on bulletin boards accessible to all employees at each location where construction work is performed.
- g) Review, at least annually, the company's EEO policy and affirmative action obligations under these specifications with all employees having any responsibility for hiring, assignment, layoff, termination or other employment decisions including specific review of these items with onsite supervisory personnel such as Superintendents, General Foreman, etc., prior to the initiation of construction work at any job site. A written record shall be made and maintained identifying the time and place of these meetings, persons attending, subject matter discussed, and disposition of the subject matter.
- h) Disseminate the Contractor's EEO policy externally by including it in any advertising in the news media, specifically including minority and female news media, and providing written notification to and discussing the Contractor's EEO policy with other Contractors and Subcontractors with whom the Contractor does or anticipates doing business.
- i) Direct its recruitment efforts, both oral and written, to minority, female and community organizations, to schools with minority and female students and to minority and female recruitment and training organizations serving the Contractor's recruitment area and employment needs. Not later than one month prior to the date for the acceptance of applications for apprenticeship or other training by any recruitment source, the Contractor shall send written notification to organizations such as the above, describing the openings, screening procedures, and tests to be used in the selection process.
- j) Encourage present minority and female employees to recruit other minority persons and women and, where reasonable, provide after school, summer and vacation employment to minority and female youth both on the site and in other areas of a Contractor's workforce.
- k) Validate all tests and other selection requirements where there is an obligation to do so under 41 CFR Part 60-3.
- l) Conduct, at least annually, an inventory and evaluation at least of all minority and female personnel for promotional opportunities and encourage these employees to seek or to prepare for, through appropriate training, etc., such opportunities.
- m) Ensure that seniority practices, job classifications, work assignments and other personnel practices, do not have a discriminatory effect by continually monitoring all personnel and employment related activities to ensure that the EEO policy and the Contractor's obligations under these specifications are being carried out.
- n) Ensure that all facilities and company activities are nonsegregated except that separate or single-user toilet and necessary changing facilities shall be provided to assure privacy between the sexes.
- o) Document and maintain a record of all solicitations of offers for subcontracts from minority and female construction Contractors and suppliers, including circulation of solicitations to minority and female Contractor associations and other business associations.

Revised 08-31-83

- p) Conduct a review, at least annually, of all supervisors' adherence to and performance under the Contractor's EEO policies and affirmative action obligations.
8. Contractors are encouraged to participate in voluntary associations which assist in fulfilling one or more of their affirmative action obligations (7a through p). The efforts of a Contractor association, joint Contractor-union, Contractor-community, or other similar group of which the Contractor is a member and participant, may be asserted as fulfilling any one or more of its obligations under 7a through p of these Specifications provided that the Contractor actively participates in the group, makes every effort to assure that the group has a positive impact on the employment of minorities and women in the industry, ensures that the concrete benefits of the program are reflected in the Contractor's minority and female workforce participation makes a good faith effort to meet its individual goals and timetables, and can provide access to documentation which demonstrates the effectiveness of actions taken on behalf of the Contractor. The obligation to comply, however, is the Contractor's and failure of such a group to fulfill an obligation shall not be a defense for the Contractor's noncompliance.
9. A single goal for minorities and a separate single goal for women have been established. The Contractor, however, is required to provide equal employment opportunity and to take affirmative action for all minority groups, both male and female, and all women, both minority and non-minority. Consequently, the Contractor may be in violation of the Executive Order if a particular group is employed in a substantially disparate manner (for example, even though the Contractor has achieved its goals for women generally, the Contractor may be in violation of the Executive Order if a specified minority group of women is underutilized).
10. The Contractor shall not use the goals and timetables or affirmative action standards to discriminate against any person because of race, color, religion, sex, or national origin.
11. The Contractor shall not enter into any Subcontract with any person or firm debarred from Government contracts pursuant to Executive Order 11246.
12. The Contractor shall carry out such sanctions and penalties for violation of these specifications and of the Equal Opportunity Clause, including suspension, termination and cancellation of existing subcontracts as may be imposed or ordered pursuant to Executive Order 11246, as amended, and its implementing regulations, by the Office of Federal Contract Compliance Programs. Any Contractor who fails to carry out such sanctions and penalties shall be in violation of these specifications and Executive Order 11246, as amended.
13. The Contractor, in fulfilling its obligations under these specifications, shall implement specific affirmative action steps, at least as extensive as those standards prescribed in paragraph 7 of these specifications, so as to achieve maximum results from its efforts to ensure equal opportunity. If the Contractor fails to comply with the requirements of the Executive Order, the implementing regulations, or these specifications, the Director shall proceed in accordance with 41 CFR 60-4.8.
14. The Contractor shall designate a responsible official to monitor all employment related activity to ensure that the company EEO policy is being carried out, to submit reports relating to the provisions hereof as may be required by the Government and to keep records. Records shall at least include for each employee the name, address, telephone numbers, construction trade, union affiliation if any, employee identification number when assigned, social security number, race, sex, status (e.g., mechanic, apprentice, trainee, helper, or laborer), dates of changes in status, hours worked per week in the indicated trade, rate of pay, and locations at which the work was performed. Records shall be maintained in an easily understandable and retrievable form; however, to the degree that existing records satisfy his requirement, Contractors shall not be required to maintain separate records.
15. Nothing herein provided shall be construed as a limitation upon the application of other laws which establish different standards of compliance or upon the application of requirements for the hiring of local or other area residents (e.g., those under the Public Works Employment Act of 1977 and the Community Development Block Grant Program).

Revised 08-31-83

ANNUAL EEO-1 REPORT TO JOINT REPORTING COMMITTEE AS REQUIRED AT

41 CFR 60-1.7(a)

Any Contractor having a Federal contract of \$50,000 or more and 50 or more employees is required to file annual compliance reports on Standard Form 100 (EEO-1) with the Joint Reporting Committee in accordance with the instructions provided with the form. The Contractor will provide a copy of such a report to the contracting agency within 30 days after the award of a contract.

The Contractor shall require its subcontractors to file an SF 100 within 30 days after award of the subcontract if (1) it is not exempt from the provisions of these regulations in accordance with 60-1.5, (2) has 50 or more employees, (3) first tier subcontractor, and (4) has a subcontract amounting to \$50,000 or more.

Subcontractors below the first tier which perform construction work at the site of construction shall be required to file such a report if (1) it is not exempt from the provisions of these regulations in accordance with 60-1.5, (2) has 50 or more employees and has a subcontract amounting to \$50,000 or more.

The SF 100 is available at the following address:

Joint Reports Committee
EEOC - Survey Division
1801 "L" Street N.W.
Washington, D.C. 20750

Phone (202) 663-4968

DISADVANTAGED BUSINESS POLICY

I. NOTICE

This proposal contains the special provision entitled "Required Disadvantaged Business Participation." Inclusion of this Special Provision in this contract satisfies the obligations of the Department of Transportation under federal law as implemented by 49 CFR 23 and under the Illinois "Minority and Female Business Enterprise Act."

II. POLICY

It is public policy that the businesses defined in 49 CFR Part 23 shall have the maximum opportunity to participate in the performance of contracts financed in whole or in part with State or Federal funds. Consequently, the requirements of 49 CFR Part 23 apply to this contract.

III. OBLIGATION

The Contractor agrees to ensure that the businesses defined in 49 CFR Part 23 have the maximum opportunity to participate in the performance of this contract. In this regard, the Contractor shall take all necessary and reasonable steps, in accordance with 49 CFR Part 23, to ensure that the said businesses have the maximum opportunity to compete for and perform portions of this contract. The Contractor shall not discriminate on the basis of race, color, national origin, or sex in the selection and retention of subcontractors, including procurement of materials and leases of equipment.

The Contractor shall include the above Policy and Obligation statements of this Special Provision in every subcontract, including procurement of materials and leases of equipment.

IV. DBE/WBE CONTRACTOR FINANCE PROGRAM

On contracts where a loan has been obtained through the DBE/WBE Contractor Finance Program, the Contractor shall cooperate with the Department by making all payments due to the DBE/WBE Contractor by means of a two-payee check payable to the Lender (Bank) and the Borrower (DBE/WBE Contractor).

V. BREACH OF CONTRACT

Failure to carry out the requirements set forth above and in the Special Provision shall constitute a breach of contract and may result in termination of the contract or liquidated damages as provided in the special provision.

(Rev. 9/21/92)

State of Illinois
Department of Transportation

SPECIAL PROVISION
FOR
DISADVANTAGED BUSINESS ENTERPRISE PARTICIPATION

- I. **FEDERAL OBLIGATION:** The Department of Transportation, as a recipient of federal financial assistance, is required to take all necessary and reasonable steps to ensure nondiscrimination in the award and administration of contracts. Consequently, the federal regulatory provisions of 49 CFR part 26 apply to this contract concerning the utilization of disadvantaged business enterprises. This Special Provision will also be used by the Department to satisfy the requirements of the Business Enterprise for Minorities, Females, and Persons with Disabilities Act, 30 ILCS 575. For the purposes of this Special Provision, a disadvantaged business enterprise (DBE) means a business certified by the Department in accordance with the requirements of 49 CFR part 26 and listed in the DBE Directory or most recent addendum.
- II. **CONTRACTOR ASSURANCE:** The Contractor makes the following assurance and agrees to include the assurance in each subcontract that the Contractor signs with a subcontractor:
- The contractor, subrecipient or subcontractor shall not discriminate on the basis of race, color, national origin, or sex in the performance of this contract. The contractor shall carry out applicable requirements of 49 CFR part 26 in the award and administration of federally-assisted contracts. Failure by the contractor to carry out these requirements is a material breach of this contract, which may result in the termination of this contract or such other remedy as the recipient deems appropriate.
- III. **OVERALL GOAL SET FOR THE DEPARTMENT:** As a requirement of compliance with 49 CFR part 26, the Department has set an overall goal for DBE participation in its federally assisted contracts. That goal is 22.7% of all federal-aid funds the Department will expend in its federally assisted contracts for the subject reporting fiscal year. The Department is required to make a good faith effort to achieve this goal. The dollar amount paid to all approved DBE firms performing work called for in this contract is eligible to be credited toward fulfillment of the Department's overall goal.
- IV. **CONTRACT GOAL TO BE ACHIEVED BY THE CONTRACTOR:** This contract includes a specific DBE utilization goal established by the Department. The goal has been included because the Department has determined that the work of this contract has subcontracting opportunities that may be suitable for performance by DBE companies. This determination is based on an assessment of the type of work, the location of the work, and the availability of DBE companies to do a part of the work. The assessment indicates that, in the absence of unlawful discrimination, and in an arena of fair and open competition, DBE companies can be expected to perform **12.0%** of the work. This percentage is set as the DBE participation goal for this contract. Consequently, in addition to the other award criteria established for this contract, the Department will award this contract to a bidder who makes a good faith effort to meet this goal of DBE participation in the performance of the work. A bidder makes a good faith effort for award consideration if either of the following is done in accordance with the procedures set forth in this Special Provision:
- A. The bidder documents that firmly committed DBE participation has been obtained to meet the goal; or
- B. The bidder documents that a good faith effort has been made to meet the goal, even though the effort did not succeed in obtaining enough DBE participation to meet the goal.

- V. DBE LOCATOR REFERENCES: Bidders may consult the DBE Directory as a reference source for DBE companies certified by the Department. In addition, the Department maintains a letting and item specific DBE locator information system whereby DBE companies can register their interest in providing quotes on particular bid items advertised for letting. Information concerning DBE companies willing to quote work for particular contracts may be obtained by contacting the Department's Bureau of Small Business Enterprises at telephone number (217)785-4611, or by visiting the Department's web site at www.dot.state.il.us.
- VI. BIDDING PROCEDURES: Compliance with the bidding procedures of this Special Provision is required prior to the award of the contract and the failure of the as-read low bidder to comply will render the bid nonresponsive.
- A. In order to assure the timely award of the contract, the as-read low bidder must submit a Disadvantaged Business Utilization Plan on Department form SBE 2026 within seven (7) working days after the date of letting. To meet the seven (7) day requirement, the bidder may send the Plan by certified mail or delivery service within the seven (7) working day period. If a question arises concerning the mailing date of a Plan, the mailing date will be established by the U.S. Postal Service postmark on the original certified mail receipt from the U.S. Postal Service or the receipt issued by a delivery service. It is the responsibility of the as-read low bidder to ensure that the postmark or receipt date is affixed within the seven (7) working days if the bidder intends to rely upon mailing or delivery to satisfy the submission day requirement. The Plan is to be submitted to the Department of Transportation, Bureau of Small Business Enterprises, Contract Compliance Section, 2300 South Dirksen Parkway, Room 319, Springfield, Illinois 62764 (Telefax: (217) 785-1524). It is the responsibility of the bidder to obtain confirmation of telefax delivery. The Department will not accept a Utilization Plan if it does not meet the seven (7) day submittal requirement, and the bid will be declared nonresponsive. In the event the bid is declared nonresponsive due to a failure to submit a Plan or failure to comply with the bidding procedures set forth herein, the Department may elect to cause the forfeiture of the penal sum of the bidder's proposal guaranty, and may deny authorization to bid the project if re-advertised for bids. The Department reserves the right to invite any other bidder to submit a Utilization Plan at any time for award consideration or to extend the time for award.
- B. The Utilization Plan shall indicate that the bidder either has obtained sufficient DBE participation commitments to meet the contract goal or has not obtained enough DBE participation commitments in spite of a good faith effort to meet the goal. The Utilization Plan shall further provide the name, telephone number and telefax number of a responsible official of the bidder designated for purposes of notification of plan approval or disapproval under the procedures of this Special Provision.
- C. The Utilization Plan shall include a DBE Participation Commitment Statement, Department form SBE 2025, for each DBE proposed for the performance of work to achieve the contract goal. The signatures on these forms must be original signatures. All elements of information indicated on the said form shall be provided, including but not limited to the following:
1. The name and address of each DBE to be used;
 2. A description, including pay item numbers, of the commercially useful work to be done by each DBE;
 3. The price to be paid to each DBE for the identified work specifically stating the quantity, unit price and total subcontract price for the work to be completed by the DBE. If partial pay items are to be performed by the DBE, indicate the portion of each item, a unit price where appropriate and the subcontract price amount;
 4. A commitment statement signed by the bidder and each DBE evidencing availability and intent to perform commercially useful work on the project; and
 5. If the bidder is a joint venture comprised of DBE firms and non-DBE firms, the plan must also include a clear identification of the portion of the work to be performed by the DBE partner(s).

D. The contract will not be awarded until the Utilization Plan submitted by the bidder is approved. The Utilization Plan will be approved by the Department if the Plan commits sufficient commercially useful DBE work performance to meet the contract goal. The Utilization Plan will not be approved by the Department if the Plan does not commit sufficient DBE performance to meet the contract goal unless the bidder documents that it made a good faith effort to meet the goal. The good faith procedures of Section VIII of this special provision apply. If the Utilization Plan is not approved because it is deficient in a technical matter, unless waived by the Department, the bidder will be notified and will be allowed no less than a five (5) working day period in order to cure the deficiency.

VII. CALCULATING DBE PARTICIPATION: The Utilization Plan values represent work anticipated to be performed and paid for upon satisfactory completion. The Department is only able to count toward the achievement of the overall goal and the contract goal the value of payments made for the work actually performed by DBE companies. In addition, a DBE must perform a commercially useful function on the contract to be counted. A commercially useful function is generally performed when the DBE is responsible for the work and is carrying out its responsibilities by actually performing, managing, and supervising the work involved. The Department and Contractor are governed by the provisions of 49 CFR part 26.55(c) on questions of commercially useful functions as it affects the work. Specific counting guidelines are provided in 49 CFR part 26.55, the provisions of which govern over the summary contained herein.

A. DBE as the Contractor: 100% goal credit for that portion of the work performed by the DBE's own forces, including the cost of materials and supplies. Work that a DBE subcontracts to a non-DBE firm does not count toward the DBE goals.

B. DBE as a joint venture Contractor: 100% goal credit for that portion of the total dollar value of the contract equal to the distinct, clearly defined portion of the work performed by the DBE's own forces.

C. DBE as a subcontractor: 100% goal credit for the work of the subcontract performed by the DBE's own forces, including the cost of materials and supplies. Work that a DBE subcontractor in turn subcontracts to a non-DBE firm does not count toward the DBE goal.

D. DBE as a trucker: 100% goal credit for trucking participation provided the DBE is responsible for the management and supervision of the entire trucking operation for which it is responsible. At least one truck owned, operated, licensed and insured by the DBE must be used on the contract. Credit will be given for the full value of all such DBE trucks operated using DBE employed drivers. Goal credit will be limited to the value of the reasonable fee or commission received by the DBE if trucks are leased from a non-DBE company.

E. DBE as a material supplier:

1. 60% goal credit for the cost of the materials or supplies purchased from a DBE regular dealer.
2. 100% goal credit for the cost of materials or supplies obtained from a DBE manufacturer.
3. 100% credit for the value of reasonable fees and commissions for the procurement of materials and supplies if not a regular dealer or manufacturer.

VIII. GOOD FAITH EFFORT PROCEDURES: If the bidder cannot obtain sufficient DBE commitments to meet the contract goal, the bidder must document in the Utilization Plan the good faith efforts made in the attempt to meet the goal. This means that the bidder must show that all necessary and reasonable steps were taken to achieve the contract goal. Necessary and reasonable steps are those which could reasonably be expected to obtain sufficient DBE participation. The Department will consider the quality, quantity and intensity of the kinds of efforts that the bidder has made. Mere *pro forma* efforts are not good faith efforts; rather, the bidder is expected to have taken those efforts that would be reasonably expected of a bidder actively and aggressively trying to obtain DBE participation sufficient to meet the contract goal.

- A. The following is a list of types of action that the Department will consider as part of the evaluation of the bidder's good faith efforts to obtain participation. These listed factors are not intended to be a mandatory checklist and are not intended to be exhaustive. Other factors or efforts brought to the attention of the Department may be relevant in appropriate cases, and will be considered by the Department.
1. Soliciting through all reasonable and available means (e.g. attendance at pre-bid meetings, advertising and/or written notices) the interest of all certified DBE companies that have the capability to perform the work of the contract. The bidder must solicit this interest within sufficient time to allow the DBE companies to respond to the solicitation. The bidder must determine with certainty if the DBE companies are interested by taking appropriate steps to follow up initial solicitations.
 2. Selecting portions of the work to be performed by DBE companies in order to increase the likelihood that the DBE goals will be achieved. This includes, where appropriate, breaking out contract work items into economically feasible units to facilitate DBE participation, even when the prime contractor might otherwise prefer to perform these work items with its own forces.
 3. Providing interested DBE companies with adequate information about the plans, specifications, and requirements of the contract in a timely manner to assist them in responding to a solicitation.
 4. (a) Negotiating in good faith with interested DBE companies. It is the bidder's responsibility to make a portion of the work available to DBE subcontractors and suppliers and to select those portions of the work or material needs consistent with the available DBE subcontractors and suppliers, so as to facilitate DBE participation. Evidence of such negotiation includes the names, addresses, and telephone numbers of DBE companies that were considered; a description of the information provided regarding the plans and specifications for the work selected for subcontracting; and evidence as to why additional agreements could not be reached for DBE companies to perform the work.

(b) A bidder using good business judgment would consider a number of factors in negotiating with subcontractors, including DBE subcontractors, and would take a firm's price and capabilities as well as contract goals into consideration. However, the fact that there may be some additional costs involved in finding and using DBE companies is not in itself sufficient reason for a bidder's failure to meet the contract DBE goal, as long as such costs are reasonable. Also, the ability or desire of a prime contractor to perform the work of a contract with its own organization does not relieve the bidder of the responsibility to make good faith efforts. Prime contractors are not, however, required to accept higher quotes from DBE companies if the price difference is excessive or unreasonable.
 5. Not rejecting DBE companies as being unqualified without sound reasons based on a thorough investigation of their capabilities. The contractor's standing within its industry, membership in specific groups, organizations, or associations and political or social affiliations (for example union vs. non-union employee status) are not legitimate causes for the rejection or non-solicitation of bids in the contractor's efforts to meet the project goal.
 6. Making efforts to assist interested DBE companies in obtaining bonding, lines of credit, or insurance as required by the recipient or contractor.
 7. Making efforts to assist interested DBE companies in obtaining necessary equipment, supplies, materials, or related assistance or services.
 8. Effectively using the services of available minority/women community organizations; minority/women contractors' groups; local, state, and Federal minority/women business assistance offices; and other organizations as allowed on a case-by-case basis to provide assistance in the recruitment and placement of DBE companies.
- B. If the Department determines that the Contractor has made a good faith effort to secure the work commitment of DBE companies to meet the contract goal, the Department will award the contract provided that it is otherwise eligible for award. If the Department determines that a good faith effort has not been made, the Department will notify the bidder of that preliminary determination by contacting the responsible company official designated in the Utilization Plan. The preliminary determination shall include a statement of reasons why good faith efforts have not been found, and may include additional good faith efforts that the bidder could take. The notification will

designate a five (5) working day period during which the bidder shall take additional efforts. The bidder is not limited by a statement of additional efforts, but may take other action beyond any stated additional efforts in order to obtain additional DBE commitments. The bidder shall submit an amended Utilization Plan if additional DBE commitments to meet the contract goal are secured. If additional DBE commitments sufficient to meet the contract goal are not secured, the bidder shall report the final good faith efforts made in the time allotted. All additional efforts taken by the bidder will be considered as part of the bidder's good faith efforts. If the bidder is not able to meet the goal after taking additional efforts, the Department will make a pre-final determination of the good faith efforts of the bidder and will notify the designated responsible company official of the reasons for an adverse determination.

- C. The bidder may request administrative reconsideration of a pre-final determination adverse to the bidder within the five (5) working days after the notification date of the determination by delivering the request to the Department of Transportation, Division of Aeronautics, 1 Langhorne Bond Drive, Capital Airport, Springfield, IL 62707-8415 (Telefax: 217-785-4533). Deposit of the request in the United States mail on or before the fifth business day shall not be deemed delivery. The pre-final determination shall become final if a request is not made and delivered. A request may provide additional written documentation and/or argument concerning the issue of whether an adequate good faith effort was made to meet the contract goal. In addition, the request shall be considered a consent by the bidder to extend the time for award. The request will be forwarded to the Department's Reconsideration Officer. The Reconsideration Officer will extend an opportunity to the bidder to meet in person in order to consider all issues of whether the bidder made a good faith effort to meet the goal. After the review by the Reconsideration Officer, the bidder will be sent a written decision within ten (10) working days after receipt of the request for reconsideration, explaining the basis for finding that the bidder did or did not meet the goal or make adequate good faith efforts to do so. A final decision by the Reconsideration Officer that a good faith effort was made shall approve the Utilization Plan submitted by the bidder and shall clear the contract for award. A final decision that a good faith effort was not made shall render the bid nonresponsive.

IX. CONTRACT COMPLIANCE: Compliance with this Special Provision is an essential part of the contract. The Department is prohibited by federal regulations from crediting the participation of a DBE included in the Utilization Plan toward either the contract goal or the Department's overall goal until the amount to be applied toward the goals has been paid to the DBE. The following administrative procedures and remedies govern the compliance by the Contractor with the contractual obligations established by the Utilization Plan. After approval of the Plan and award of the contract, the Utilization Plan and individual DBE Participation Statements become part of the contract. If the contractor did not succeed in obtaining enough DBE participation to achieve the advertised contract goal, and the Utilization Plan was approved and contract awarded based upon a determination of good faith, the total dollar value of DBE work calculated in the approved Utilization Plan as a percentage of the awarded contract value shall become the amended contract goal.

- A. No amendment to the Utilization Plan may be made without prior written approval from the Division of Aeronautics. All requests for amendment to the Utilization Plan shall be submitted to the Department of Transportation, Division of Aeronautics, 1 Langhorne Bond Drive, Capital Airport, Springfield, IL 62707-8415. Telephone number (217) 785-8514. Telefax number (217) 785-4533.
- B. All work indicated for performance by an approved DBE shall be performed, managed and supervised by the DBE executing the Participation Statement. The Contractor shall not terminate for convenience a DBE listed in the Utilization Plan and then perform the work of the terminated DBE with its own forces, those of an affiliate or those of another subcontractor, whether DBE or not, without first obtaining the written consent of the Bureau of Small Business Enterprises to amend the Utilization Plan. If a DBE listed in the Utilization Plan is terminated for reasons other than convenience, or fails to complete its work on the contract for any reason, the Contractor shall make good faith efforts to find another DBE to substitute for the terminated DBE. The good faith efforts shall be directed at finding another DBE to perform at least the same amount of work under the contract as the DBE that was terminated, but only to the extent needed to meet the contract goal or the amended contract goal. The Contractor shall notify the Division of Aeronautics of any termination for reasons other than convenience, and shall obtain approval for inclusion of the substitute DBE in the Utilization Plan. If good faith efforts following a termination of a DBE for cause are not successful, the Contractor shall contact the Division and provide a full accounting of the efforts undertaken to obtain substitute DBE participation. The Division will evaluate the good faith efforts in light of all circumstances surrounding the performance status of the contract, and determine whether the contract goal should be amended.

- C. The Contractor shall maintain a record of payments for work performed to the DBE participants. The records shall be made available to the Department for inspection upon request. After the performance of the final item of work or delivery of material by a DBE and final payment therefor to the DBE by the Contractor, but not later than thirty (30) calendar days after payment has been made by the Department to the Contractor for such work or material without regard to any retainage withheld by the Department, the Contractor shall submit a DBE Payment Report on Department form SBE 2115 to the Division's Chief Engineer. If full and final payment has not been made to the DBE, the Report shall indicate whether a disagreement as to the payment required exists between the Contractor and the DBE or if the Contractor believes that the work has not been satisfactorily completed. If the Contractor does not have the full amount of work indicated in the Utilization Plan performed by the DBE companies indicated in the Plan, the Department will deduct from contract payments to the Contractor the amount of the goal not achieved as liquidated and ascertained damages.

- D. The Department reserves the right to withhold payment to the Contractor to enforce the provisions of this Special Provision. Final payment shall not be made on the contract until such time as the Contractor submits sufficient documentation demonstrating achievement of the goal in accordance with this Special Provision or after liquidated damages have been determined and collected.

Certification of Nonsegregated Facilities - as Required by 41 CFR 60-1.8

(Applicable to (1) contracts, (2) subcontracts, and (3) agreements with applicants who are themselves performing federally assisted construction contracts, exceeding \$10,000.00 which are not exempt from the provisions of the Equal Opportunity clause).

By the submission of this bid, the bidder, offeror, applicant, or subcontractor certifies that he does not maintain or provide for his employees any segregated facilities at any of his establishments and that that he does not permit his employees to perform their services at any location, under his control, where segregated facilities are maintained. He certifies further that he will not maintain or provide for his employees any segregated facilities at any of his establishments and that he will not permit his employees to perform their services at any location, under his control, where segregated facilities are maintained. The bidder, offeror, applicant, or subcontractor agrees that a breach of his certification is a violation of the Equal opportunity clause in this contract. As used in this certification, the term "segregated facilities" means any waiting rooms, work areas, rest rooms and wash rooms, restaurants and other eating areas, time clocks, locker rooms and other storage or dressing areas, parking lots, drinking fountains, recreation or entertainment areas, transportation, and housing facilities provided for employees which are segregated by explicit directive or are in fact segregated on the basis of race, color, religion, or national origin, because of habit, local custom, or otherwise. He further agrees that (except where he has obtained identical certifications from proposed subcontractors for specific time periods) he will obtain identical certifications from proposed subcontractors prior to the award of subcontracts exceeding \$10,000.00 which are not exempt from the provisions of the Equal Opportunity clause; that he will retain such certifications in his files and that he will forward the following notice to such proposed subcontractors (except where the proposed subcontractors have submitted identical certifications for specific time periods):

**NOTICE TO PROSPECTIVE SUBCONTRACTORS OF REQUIREMENT FOR
CERTIFICATIONS OF NONSEGREGATED FACILITIES**

A certification of Nonsegregated Facilities must be submitted prior to the award of a subcontract exceeding \$10,000.00 which is not exempt from the provisions of the Equal Opportunity clause. The certification may be submitted either for each subcontract or for all subcontracts during a period (i.e., quarterly, semiannually or annually).

NOTE: The penalty for making false statements in offers is prescribed in 18 U.S.C 1001.

CERTIFICATION REGARDING DEBARMENT, SUSPENSION, AND OTHER RESPONSIBILITY MATTERS
Instructions for Certification

1. By signing and submitting this proposal, the prospective primary participant is providing the certification set out below.
2. The inability of a person to provide the certification required below will not necessarily result in denial of participation in this covered transaction. The prospective participant shall submit an explanation of why it cannot provide the certification set out below. The certification or explanation will be considered in connection with the department or agency's determination whether to enter into this transaction. However, failure of the prospective primary participant to furnish a certification or an explanation shall disqualify such person from participation in this transaction.
3. The certification in this clause is a material representation of fact upon which reliance was placed when the department or agency determined to enter into this transaction. If it is later determined that the prospective primary participant knowingly rendered an erroneous certification in addition to other remedies available to the Federal Government, the department or agency may terminate this transaction for cause of default.
4. The prospective primary participant shall provide immediate written notice to the department or agency to whom this proposal is submitted if at any time the prospective primary participant learns that its certification was erroneous when submitted or has become erroneous by reason of changed circumstances.
5. The terms "covered transaction" "debarred" "suspended" "ineligible" "lower tier covered transaction" "participant" "person" "primary covered transaction" "principal" "proposal" and "voluntarily excluded" as used in this clause have the meaning set out in the Definitions and Coverage sections of the rules implementing Executive Order 12540. You may contact the department or agency to which this proposal is being submitted for assistance in obtaining a copy of those regulations.
6. The prospective primary participant agrees by submitting this proposal that should the proposed covered transaction be entered into, it shall not knowingly enter into any lower tier covered transaction with a person who is debarred, suspended, declared ineligible, or voluntarily excluded from participation in this covered transaction unless authorized by the department or agency entering into this transaction.
7. The prospective primary participant further agrees by submitting this proposal that it will include the clause titled "Certification Regarding Debarment, Suspension, Ineligibility and Voluntary Exclusion - Lower Tier Transaction", provided by the department or agency entering into this covered transaction without modification in all lower covered transactions and in all solicitations for lower covered transactions.
8. A participant in a covered transaction may rely upon a certification of a prospective participant in a lower tier covered transaction that it is not debarred, suspended, ineligible, or voluntarily excluded from the covered transaction unless it knows that the certification is erroneous. A participant may decide the method and frequency by which it determines the eligibility of its principals. Each participant may, but is not required to check the Nonprocurement List (Tel. #).
9. Nothing contained in the foregoing shall be construed to require establishment of a system of records in order to render in good faith the certification required by this clause. The knowledge and information of a participant is not required to exceed that which is normally possessed by a prudent person in the ordinary course of business dealings.
10. Except for transactions authorized under paragraph 8 of these instructions, if a participant in a covered transaction knowingly enters into a lower tier covered transaction with a person who is suspended, debarred, ineligible, or voluntarily excluded from participation in this transaction, in addition to other remedies available to the Federal Government, the department or agency may terminate this transaction for cause or default.

Certification Regarding Debarment, Suspension, and
Other Responsibility Matters - Primary Covered Transactions

1. The prospective primary participant certifies to the best of its knowledge and belief that it and its principals:
 - a. Are not presently debarred, suspended, proposed for debarment, declared ineligible, or voluntarily excluded from covered transactions by an Federal department or agency;
 - b. Have not within a three-year period preceding this proposal been convicted of or had a civil judgment rendered against them for commission of fraud or a criminal offense in connection with obtaining, attempting to obtain or performing a public (Federal, State or Local) transaction or contract under a public transaction: violation of Federal or State antitrust statutes or commission of embezzlement, theft, forgery, bribery, falsification or destruction or destruction of records, making false statements, or receiving stolen property;
 - c. Are not presently indicted for or otherwise criminally or civilly charged by a governmental entity (Federal, State or local) with commission of any of the offenses enumerated in paragraph (1)(b) of this certification; and
 - d. Have not within a three-period preceding this application/proposal had one or more public transactions (Federal, State or local) terminated for cause or default.
2. Where the prospective primary participant is unable to certify to any of the statements in this certification, such prospective participant shall attach an explanation to this proposal.

CERTIFICATION REGARDING LOBBYING (Applicable to contracts in excess of \$100,000):

Certification for Contracts, Grants, Loans and Cooperative Agreements.

The undersigned bidder certifies, to the best of his or her knowledge and belief, that:

- (1) No Federal appropriated funds have paid or will be paid, by or behalf of the undersigned, to any person for influencing or attempting to influence an officer or employee of any agency, a Member of Congress, an Officer or employee of Congress, or an employee of a Member of Congress in connection with the awarding of any Federal contract, the making of any Federal grant, the making of any Federal loan, the entering into of any cooperative agreement, and the extension, continuation, renewal, amendment, or modification of any Federal contract, grant, loan, or cooperative agreement.
- (2) If any funds other than Federal appropriated funds have been paid or will be paid to any person for influencing or attempting to influence an officer or employee of any agency, a Member of Congress, an officer or employee of Congress, or an employee of a Member of Congress in connection with this Federal contract, grant, loan, or cooperative agreement, the undersigned shall complete and submit Standard Form-LLL, "Disclosure Form to Report Lobbying", in accordance with its instructions.
- (3) The undersigned shall require that the language of this certification be included in the award documents for all subawards at all tiers (including subcontracts, subgrants, and contracts under grants, loans, and cooperative agreements) and that all subrecipients shall certify and disclose accordingly.

This certification is a material representation of fact upon which reliance was placed when this transaction was made or entered into. Submission of this certification is a prerequisite for making or entering into this transaction imposed by Section 1352, title 31, U.S. Code. Any person who fails to file the required certification shall be subject to a civil penalty of not less than \$10,000 and not more than \$100,000 for each such failure.

WORKERS' COMPENSATION INSURANCE

Prior to the execution of his construction contract by the Illinois Department of Transportation, Division of Aeronautics, hereinafter referred to as "Division", the Contractor shall furnish to the Division certificates of insurance covering Workers' Compensation, or satisfactory evidence that this liability is otherwise taken care of in accordance with Section 4.(a) of the "Workers' Compensation Act of the State of Illinois" as amended.

Such insurance, or other means of protection as herein provided, shall be kept in force until all work to be performed under the terms of the contract has been completed and accepted in accordance with the specifications, and it is hereby understood and agreed that the maintenance of such insurance or other protection, until acceptance of the work by the Division is a part of the contract. Failure to maintain such insurance, cancellation by the Industrial Commission of its approval of such other means of protection as might have been elected, or any other act which results in lack of protection under the said "Workers' Compensation Act" may be considered as a breach of the contract.

SPECIAL PROVISION FOR DOMESTIC SOURCE FOR STEEL

Control of Materials: All steel products, as defined by the Illinois Steel Products Procurement Act, incorporated into this project shall be manufactured or produced in the United States and, in addition, shall be domestically fabricated. The Contractor shall obtain from the steel producer and/or fabricator, in addition to the mill analysis, a certification that all steel products meet these domestic source requirements.

CLAUSE TO BE INCLUDED IN ALL SOLICITATIONS,
CONTRACTS, AND SUBCONTRACTS RESULTING FROM PROJECTS FUNDED UNDER THE AIP

The Contractor or subcontractor, by submission of an offer and/or execution of a contract, certifies that it:

- a. is not owned or controlled by one or more citizens or nationals of a foreign country included in the list of countries that discriminate against U.S. firms published by the Office of the United States Trade Representative (USTR);
- b. has not knowingly entered into any contract or subcontract for this project with a Contractor that is a citizen or national of a foreign country on said list, or is owned or controlled directly or indirectly by one or more citizens or nationals of a foreign country on said list.
- c. has not procured any product nor subcontracted for the supply of any product for use on the project that is produced in a foreign country on said list.

Unless the restrictions of this clause are waived by the Secretary of Transportation in accordance with 49 CFR 30.17, no contract shall be awarded to a Contractor or subcontractor who is unable to certify to the above. If the Contractor knowingly procures or subcontracts for the supply of any product or service of a foreign country on the said list for use on the project, the Federal Aviation Administration may direct, through the sponsor, cancellation of the contract at no cost to the Government.

Further, the Contractor agrees that, if awarded a contract resulting from this solicitation, it will incorporate this provision for certification without modification in each contract and in all lower tier subcontracts. The Contractor may rely upon the certification of a prospective subcontractor unless it has knowledge that the certification is erroneous.

The Contractor shall provide immediate written notice to the sponsor if the Contractor learns that its certification or that of a subcontractor was erroneous when submitted or has become erroneous by reason of changed circumstances. The subcontractor agrees to provide immediate written notice to the Contractor, if at any time it learns that its certification was erroneous by reason of changed circumstances.

This certification is a material representation of fact upon which reliance was placed when making the award. If it is later determined that the Contractor or subcontractor knowingly rendered an erroneous certification, the Federal Aviation Administration may direct, through this sponsor, cancellation of the contract or subcontract for default at no cost to the Government.

Nothing contained in the foregoing shall be construed to require establishment of a system of records in order to render, in good faith, the certification required by this provision. The knowledge and information of a Contractor is not required to exceed that which is normally possessed by a prudent person in the ordinary course of business dealings.

This certification concerns a matter within the jurisdiction of an agency of the United States of America and the making of false, fictitious, or fraudulent certification may render the maker subject to prosecution under Title 18, United States Code, Section 1001.

**MINIMUM WAGES FOR FEDERAL AND FEDERALLY
ASSISTED CONSTRUCTION CONTRACTS**

This project is funded, in part, with Federal-aid funds and, as such, is subject to the provisions of the Davis-Bacon Act of March 3, 1931, as amended (46 Sta. 1494, as amended, 40 U.S.C. 276a) and of other Federal statutes referred to in a 29 CFR Part 1, Appendix A, as well as such additional statutes as may from time to time be enacted containing provisions for the payment of wages determined to be prevailing by the Secretary of Labor in accordance with the Davis-Bacon Act and pursuant to the provisions of 29 CFR Part 1. The prevailing rates and fringe benefits shown in the General Wage Determination Decisions issued by the U.S. Department of Labor shall, in accordance with the provisions of the foregoing statutes, constitute the minimum wages payable on Federal and federally assisted construction projects to laborers and mechanics of the specified classes engaged on contract work of the character and in the localities described therein.

General Wage Determination Decisions, modifications and supersedes decisions thereto are to be used in accordance with the provisions of 29 CFR Parts 1 and 5. Accordingly, the applicable decision, together with any modifications issued, must be made a part of every contract for performance of the described work within the geographic area indicated as required by an applicable DBRA Federal prevailing wage law and 29 CFR Part 5. The wage rates and fringe benefits contained in the General Wage Determination Decision shall be the minimum paid by contractors and subcontractors to laborers and mechanics.

NOTICE

The most current **General Wage Determination Decisions** (wage rates) are available on the IDOT web site. They are located on the Letting and Bidding page at <http://www.dot.state.il.us/desenv/delett.html>.

In addition, ten (10) days prior to the letting, the applicable Federal wage rates will be e-mailed to subscribers. It is recommended that all contractors subscribe to the Federal Wage Rates List or the Contractor's Packet through IDOT's subscription service.

PLEASE NOTE: if you have already subscribed to the Contractor's Packet you will automatically receive the Federal Wage Rates.

The instructions for subscribing are at <http://www.dot.state.il.us/desenv/subsc.html>.

If you have any questions concerning the wage rates, please contact IDOT's Chief Contract Official at 217-782-7806.

SECTION III
SPECIAL PROVISIONS
FOR
**CONSTRUCT SOUTHEAST QUADRANT FIRE
PROTECTION**

ILLINOIS PROJECT: IKK-3661
AIP PROJECT: 3-17-0057-B13

AT

GREATER KANKAKEE AIRPORT
KANKAKEE, ILLINOIS

January 26, 2007

Prepared by:

CRAWFORD, MURPHY & TILLY, INC.
CONSULTING ENGINEERS
600 NORTH COMMONS DRIVE, SUITE 107
AURORA, ILLINOIS 60504
(630) 820-1022
(630) 820-0350
<http://www.cmtengr.com>

06075-02-00



2/12/09
Exp: 11/30/09

GENERAL

These Special Provisions, together with applicable Standard Specifications, Supplemental Specifications, Recurring Special Provisions, Rules and Regulations, Contract Requirements for Airport Improvement Projects, Payroll Requirements and Minimum Wage Rates which are hereto attached or which by reference are herein incorporated, cover the requirements of the State of Illinois, Department of Transportation, Division of Aeronautics for the construction of the subject project at the Greater Kankakee Airport, Kankakee, Illinois.

GOVERNING SPECIFICATIONS AND RULES AND REGULATIONS

The "Standard Specifications for Construction of Airports", dated January 1985, State of Illinois Department of Transportation, Division of Aeronautics, and the "Supplemental Specifications and Recurring Special Provisions", dated July 1, 2004 (or latest edition), State of Illinois Department of Transportation, Division of Aeronautics, indicated on the Check Sheet included herein shall govern the project except as otherwise noted in these Special Provisions. In cases of conflict with any part or parts of said specifications, the said Special Provisions shall take precedence and shall govern. As noted within the Special Provisions the Illinois Department of Transportation "Standard Specifications for Road and Bridge Construction" dated January 1, 2007 shall apply.

INDEX TO SPECIAL PROVISIONS

<u>ITEM</u>	<u>DESCRIPTION</u>	<u>STARTING PAGE NUMBER</u>
DIVISION I GENERAL PROVISIONS		1
DIVISION II PAVING CONSTRUCTION DETAILS		5
208	Aggregate Base Course	5
401	Remove and Replace Bituminous Pavement	5
602	Bituminous Prime Coat	7
603	Bituminous Tack Coat	8
610	Structural Portland Cement Concrete	8
DIVISION III FENCING		9
162	Chain Link Fences	9
DIVISION IV DRAINAGE PIPE		11
701	Pipe For Storm Sewers and Culverts	11
DIVISION V TURFING		13
901	Seeding	13
905	Topsoiling	15
DIVISION VIII MISCELLANEOUS		16
156000	Erosion Control	16
760	Water Main	17
770	Sanitary Sewer	23
800019	Freshwater Well Abandonment	25

IDOT STANDARDS

664001-01 Chain Link Fence

IDOT DIVISION OF AERONAUTICS POLICY MEMORANDUMS

96-1 Item 610 Structural Portland Cement Concrete: Job
Mix Formula Approval & Production Testing

APPENDIX

Aqua Illinois Standard Specifications for the Construction of Water
Main

DIVISION I - GENERAL PROVISIONS

10-23 ENGINEER

DELETE: Paragraph (b).

20-05 MAINTENANCE OF TRAFFIC

ADD:

The Contractor shall be responsible for cleaning and maintaining all haul roads and use a pick-up type sweeper on all pavements and adjacent roadways utilized in hauling operations when material is tracked onto said pavement. The Contractor shall have a sweeper on site and maintain all pavements clear of dirt and debris at all times or as requested by the Resident Engineer. If the Contractor fails to comply with the Standard Specifications, Contract Plans or these Special Provisions concerning traffic control, the Resident Engineer shall execute such work as may be deemed necessary to correct deficiencies, and the cost thereof shall be deducted from compensation due or which may become due the Contractor under the contract. The Contractor shall be responsible for supplying, maintaining and moving all barricades required for construction. The cost thereof shall not be paid for separately, but shall be considered incidental to the contract unit prices.

The Airport Manager, following consultation with the Resident Engineer, will give proper notice to the nearest Flight Service Station and the Airways Facilities Chief of the Federal Aviation Administration prior to the beginning of construction. The Contractor shall furnish a flagger in radio control with the Air Traffic Control Tower at any time the active taxiways or airfield pavement are crossed or used for a haul road. The Contractor shall supply his own radios. The cost thereof shall not be paid for separately, but shall be considered incidental to the contract unit prices.

20-09 AIRPORT OPERATIONS DURING CONSTRUCTION

a. Construction Activity and Aircraft Movements

For construction activity to be performed in other areas than active operational areas, the storage and parking of equipment and materials, when not in use or about to be installed, shall not encroach upon active operational areas. In protecting operational areas, the minimum clearances maintained for runways shall be in conformance with Part 77 of the Federal Aviation Regulations.

All construction operations shall conform to the plans and in accordance with AC 150/5370-2e (Latest Edition) Operational Safety on Airports During Construction.

b. Limitations On Construction

- (1) Open flame welding or torch cutting operations shall be prohibited, unless adequate fire and safety precautions are provided.
- (2) Open trenches, excavations and stockpiled material near any pavements shall be prominently marked with red flags and lighted by light units during hours of restricted visibility and/or darkness.
- (3) Stockpiled material shall be constrained in a manner to prevent movement resulting from aircraft blast or wind conditions.
- (4) The use of explosives shall be prohibited.
- (5) Burning shall not be allowed.

c. Debris

Waste and loose material capable of causing damage to aircraft landing gears, propellers, or being ingested in jet engines shall not be placed on active aircraft movement areas. Material tracked on these areas shall be removed continuously during the work project. The Contractor shall provide garbage cans in employee parking areas and storage areas for debris.

30-18 PLANS AND WORK DRAWINGS

REVISE the second paragraph of the Supplemental Specifications to read:

Shop drawings submitted by the Contractor for materials and/or equipment to be provided as a part of the contract shall be reviewed by the Project Engineer for substantial conformance of said materials and/or equipment, to contract requirements. Shop drawings shall be full descriptive, complete and of sufficient detail for ready determination of compliance.

REVISE the last paragraph of the Supplemental Specifications to read:

The following information shall be clearly marked on each shop, working, and layout drawing, catalog cut, pamphlet specifications sheet, etc., submitted.

PROJECT LOCATION: Greater Kankakee Airport

PROJECT TITLE: Construct Southeast Quadrant Fire Protection

PROJECT NUMBERS IL Project: IKK-XXX

CONTRACT ITEM: (i.e. AR 156510 Silt Fence)

SUBMITTED BY: (Contractor/Subcontractor Name)

DATE: (Date Submitted)

40-03 CERTIFICATION OF COMPLIANCE

ADD:
Additional requirements are specified in Section 40-11 Certification of Materials.

40-11 CERTIFICATION OF MATERIALS

ADD:
The Contractor shall certify all materials incorporated into the contract. Certification documentation shall be submitted to the Resident Engineer. **It shall be the sole responsibility of the Contractor to ensure the submittal of adequate and accurate documentation in order to satisfy the contract material certification requirements prior to the delivery of the materials. Materials without certification or those with certification that demonstrates the materials do not meet the requirements of the plans and specifications shall be considered nonconforming and subject to the provisions of Section 30-02 of the Standard Specifications.**

As a guide to the certification process and requirements, the Contractor shall use the Illinois Department of Transportation/Division of Aeronautics MANUAL FOR DOCUMENTATION OF AIRPORT MATERIALS dated February 2002 or latest edition including any addendums. Copies of this manual are available by contacting Mr. Rick Borus-Division of Aeronautics at (217) 785-0056.

The cost of providing the required material documentation and certifications shall not be paid for separately, but shall be considered incidental to the associated item.

All submittals shall contain the following information:

- Airport Name
- Project Title
- IL Project No.
- AIP Project No.
- Pay Item No.
- Quantity

50-17 CONTRACTOR'S RESPONSIBILITY FOR UTILITY SERVICE AND FACILITIES OF OTHERS

ADD:

Special care shall be taken on all operations to avoid damage to all underground facilities on the construction site. The approximate location of existing facilities shown on drawings will be made available to the Contractor upon request of the Resident Engineer to the extent that they are available. Any facilities which are damaged during construction and which require replacement shall be done by the Contractor at no additional cost to the Owner. Should the Contractor fail to respond to notification received from the Resident Engineer or his authorized representative to repair or replace damaged facilities within two hours, the Resident Engineer shall execute such work as may be deemed necessary to repair the damage, and the cost thereof shall be deducted from the compensation due or which may become due the Contractor under the contract.

It shall be the Contractor's responsibility to locate and protect all airport owned utilities within the construction limits. This includes all electrical airfield cables, storm sewer, drain tile, sanitary sewer and watermain.

Should any utilities or cables require location, the following people should be contacted:

<u>Utility Service or Facility</u>	<u>Contact (Person)</u>	<u>Contact (Phone)</u>
AT&T, Commonwealth Edison, NICOR Gas, Comcast	J.U.L.I.E. (Joint Utility Locating Information for Excavators)	1-800-892-0123
Aqua Illinois – Watermain	Supervisor of Construction	(815) 935-6538
City of Kankakee – Sanitary Sewer	Randy Collins	(815) 933-0445
Airfield Lighting Cables and Water Lines	Kankakee Valley Airport Authority Jason Licon	(815) 939-1422

60-03 NOTICE TO PROCEED

ADD:

The Notice to Proceed will not be given until all materials are certified by the Contractor to be available and on hand.

60-05 LIMITATION OF OPERATIONS

The Contractor shall not have access to any part of the active airfield (runways or taxiways) for any equipment or personnel without approval of the Airport Manager.

60-07 TEMPORARY SUSPENSION OF THE WORK

Replace references to "Resident Engineer" with "Engineer" throughout this section.

60-09 FAILURE TO COMPLETE ON TIME

DELETE: Entire Section.

ADD: See contract documents for liquidated damages schedule.

60-10 DEFAULT AND TERMINATION OF CONTRACT

Replace references to "Project Engineer" with "Engineer" throughout this section.

70-05 PAYMENT FOR EXTRA AND FORCE ACCOUNT WORK

DELETE: Entire Section.

ADD:

Article 109.4 Payment for Extra Work from the Illinois Department of Transportation, *Standard Specifications for Road and Bridge Construction*, Adopted January 1, 2002.

Revise Article 109.04 (b) (1) to read as follows:

- (1) Labor. For all labor and foreman in direct charge of the specific operations, the Contractor shall receive the actual normal rate of wage (in conformance with the county's prevailing wage rate) paid for each and every hour that said labor and foremen are **actually engaged** in such work.

An amount equal to 35 percent of the sum of the above items will also be paid the Contractor.

DIVISION II PAVING CONSTRUCTION DETAILS

ITEM 208 AGGREGATE BASE COURSE

DESCRIPTION

208-1.1

ADD:

This item shall include all aggregates used in trench backfill and other miscellaneous aggregate.

MATERIALS

208-2.1 PARTIALLY CRUSHED COARSE AGGREGATE

DELETE: This paragraph of the Supplemental Specifications.

208-2.5 AGGREGATE MATERIAL CONTRACTOR'S RESPONSIBILITY

Samples of the aggregate that the Contractor proposes to use along with a statement of their source and character shall be submitted to the Resident Engineer 10 working days prior to the Contractor starting work on this item.

CONSTRUCTION METHODS

208-3.4 METHODS OF PRODUCTION

ADD:

When materials from several sources must be blended and mixed, the aggregate material shall be processed in a central or travel mixing plant. After the mixing is complete, the material shall be transported to and spread on the underlying course.

Mixing of materials in place will not be allowed.

METHOD OF MEASUREMENT

208-4.1

DELETE: Entire section of the Standard and Supplemental Specifications.

BASIS OF PAYMENT

208-5.1

DELETE: Entire section of the Standard and Supplemental Specifications.

ADD: No direct payment will be made for the aggregate base course. The cost of furnishing and installing aggregate base course shall be considered incidental to the contract unit prices for the respective pay items utilizing the aggregate. These prices shall be full compensation for furnishing all materials and for all preparation, delivering and installation of these materials, and for all labor, tools and incidentals necessary to complete this item.

ITEM 401910 - REMOVE AND REPLACE BITUMINOUS PAVEMENT

DESCRIPTION

401910-1.1

This item shall consist of bituminous pavement removal and replacement for various utility crossings and patches as shown on the plans. The pavement shall be compacted in accordance with these specifications and shall conform to the lines, grades, thicknesses and typical sections as shown on the plans or as directed by the Engineer.

Bituminous pavement replacement shall consist of a maximum lift thickness of 2". All lifts shall be of bituminous surface course (401) material. **All proposed patch depths must match the adjacent pavement thickness when the existing pavement structure is 4" or greater in depth. When the existing pavement structure is four inches or less, the proposed pavement patch shall be a minimum of four inches of bituminous surface course.**

Each course shall be constructed to the depth, section or elevation required by the plans and shall be rolled, finished and approved prior to the placement of the next course.

MATERIALS

401910-2.1 BITUMINOUS SURFACE COURSE

This material shall be in accordance with "Under 60,000 lb. in Table 2 of ITEM 401001 – Bituminous Surface Course – Method 1 of the State of Illinois Department of Transportation, Division of Aeronautics "Supplemental Specifications and Recurring Special Provisions", dated July 1, 2004 (or latest edition). Alternate IDOT-approved mix designs may be submitted to the Engineer for consideration.

401910-2.2 BITUMINOUS PRIME COAT

The bituminous prime coat shall conform to the specifications of Section 602.

401910-2.3 BITUMINOUS TACK COAT

The bituminous tack coat shall conform to the specifications of Section 603.

CONSTRUCTION METHODS

401910-3.1

The type of material to be removed along with approximate typical pavement section is shown on the plans. Pavement structure information was taken from airport records and data supplied by airport personnel. The Contractor shall verify the type and thickness of material to be removed. **No extra compensation will be allowed for any variations in the pavement sections actually encountered.**

401910-3.2

The proposed pavement replacement section shall be as specified herein. Prime coat shall be applied to the aggregate base. Tack coat shall be applied between each lift of asphalt or as determined by the Resident Engineer.

401910-3.3

The existing pavement areas to be removed shall be done in such a manner as to prevent damage to the adjacent pavements. All edges adjacent to existing pavements shall be saw-cut full depth prior to removal, as directed by the Engineer.

401910-3.4

Pavement replacement will be as detailed on the plans and constructed in accordance to the applicable Sections 401, 602 & 603. The various materials required for pavement replacement shall be in accordance with the applicable portions of the Standard Specifications and these Special Provisions. Any damage to pavement beyond the limits as shown on the plans **shall be removed and replaced by the Contractor at his expense. These areas shall be saw cut to a uniform width.**

401910-3.5

Pavement Removal and Replacement shall be the removal of the existing pavements as shown on the plans and the replacement pavement shall match the existing pavement. Aggregate base course/trench backfill for the water main pipe shall be paid for separately under trench backfill, as appropriate, but should not be considered part of this pay item.

METHOD OF MEASUREMENT

401910-4.1

The area of pavement removal and replacement shall be measured by the number of square yards, satisfactorily removed, disposed of and replaced and as shown on the plans or as directed by the Engineer.

401910-4.2

If additional pavement or subgrade material is removed due to negligence on the part of the Contractor, the additional quantity of pavement removal and replacement of subgrade material will not be measured for payment.

401910-4.3

The bituminous surface course, bituminous prime coat and bituminous tack coat will not be measured separately for payment, but will be considered incidental to REMOVE & REPLACE BIT. PAVEMENT per square yard.

BASIS OF PAYMENT

401910-5.1

Payment for REMOVE & REPLACE BIT. PAVEMENT shall be made at the contract unit price per square yard. This price shall include full compensation for sawing, removal, disposal, replacement of asphalt materials, compaction, prime coat, tack coat, including furnishing all materials, labor, tools, equipment and incidentals necessary to complete this item of work.

Any grading and recompacting of existing granular base course to proper grade shall not be paid for separately but shall be considered incidental to Remove & Replace Bituminous Pavement.

Payment will be made under:

ITEM AR401910 REMOVE & REPLACE BIT. PAVEMENT - PER SQUARE YARD.

ITEM 602-BITUMINOUS PRIME COAT

DESCRIPTION

602-1.2 QUANTITIES OF BITUMINOUS MATERIAL

REVISE: This section of the Supplemental Specifications to read:

After the base has been prepared, and when in dry condition, the bituminous material shall be applied uniformly at a rate of 0.30 gal/sy.

BASIS OF PAYMENT

602-5.1

DELETE: Entire section of the Standard and Supplemental Specifications.

ADD: No payment will be made for this item. It will be considered incidental to the removal and replacement of the bituminous pavement.

ITEM 603 - BITUMINOUS TACK COAT

BASIS OF PAYMENT

603-5.1

DELETE: Entire section of the Standard and Supplemental Specifications.

ADD: No payment will be made for this item. It will be considered incidental to the removal and replacement of the bituminous pavement.

ITEM 610 - STRUCTURAL PORTLAND CEMENT CONCRETE

CONSTRUCTION METHODS

610-3.2 CONCRETE PROPORTIONS

REPLACE: the last sentence of the sixth paragraph of Standard Specifications with "The air content of the concrete shall be between 5% and 8%, by volume."

DIVISION III - FENCING

ITEM 162-CHAIN LINK FENCES

DESCRIPTION

162-1.1

This item shall consist of removing and replacing the existing fence to facilitate the construction of the water main. The item shall consist of utilizing the existing fence components with the exception of the line posts and foundations. These components shall be furnished under this item.

MATERIALS

162-2.1 FABRIC

ADD:

The chain link fence shall be zinc coated steel fabric or aluminum coated steel fabric.

162-2.2 BARBED WIRE

DELETE: Entire Section. No barbed wire required.

162-2.3 FENCE POSTS, POST TOPS AND EXTENSIONS, RAIL, GATES, BRACES, STRETCHER BARS AND CLIPS

ADD:

Line Posts. The posts shall be Type A or B. The posts shall have a nominal O.D. of 1.90 inches and weigh at least 2.72 pounds per foot for Type A and 2.28 pounds per foot for Type B.

Terminal Posts (End, Corner, or Pull). Terminal post shall be Type A or B. Terminal posts shall be 2-3/8" O.D. weighing at least 3.65 pounds per foot for Type A or 3.11 pounds per foot for Type B.

162-2.4 WIRE TIES AND TENSION WIRE

ADD:

Coiled spring tension wire of at least 7 gauge O.D. aluminum coated steel wire shall be stretched along the bottom of the fence and securely fastened to the fabric with hog rings at 2 foot intervals. Fabric ties shall not be less than a 9-gauge aluminum wire.

162-2.10 CERTIFICATION AND SHOP DRAWINGS

ADD:

The Contractor shall provide written certification that all materials meet specification requirements prior to start of the work. Shop drawings shall be submitted to the Engineer for review prior to the construction of fence.

CONSTRUCTION METHODS

162-3.10 FENCE AND GATE REMOVAL

ADD:

The Contractor shall remove, without regard to the type, the existing fence, rails, post, foundations, miscellaneous hardware, at the locations shown on the plans. The Contractor shall salvage the fence fabric, rails, posts and miscellaneous hardware for reuse. The remaining fence materials, fence post, foundations, and miscellaneous materials not salvaged shall become the property of the Contractor and shall be disposed of off Airport Property. Any items needed to reinstall the fence that could not be salvaged during its removal shall be furnished by the Contractor.

BASIS OF PAYMENT

162-5.1

ADD:

Fence removal and replacement, disposal of all posts, hardware, foundations, furnishing new materials when necessary, for all transporting and disposal cost and for all labor, equipment, tools and incidentals necessary to complete this item to the satisfaction of the Engineer shall not be paid for separately, but shall be considered incidental to the proposed fence removal and replacement.

Payment will be made under:

ITEM AR800054 REMOVE AND REPLACE FENCE – PER LINEAL FEET.

DIVISION IV - DRAINAGE PIPE

ITEM 701 – PIPE FOR STORM SEWERS AND CULVERTS

DESCRIPTION

701-1.1

ADD:

This item shall also consist of the removal of the existing storm sewer, sanitary sewer, field tile and drain pipe as shown on the plans or as directed by the Engineer.

MATERIALS

701-2.1

DELETE: Entire Section.

ADD:

Pipe shall be of the class, type and diameter indicated and installed at the location shown on the plans. Reinforced concrete pipe shall conform to ASTM C-76 (with joints meeting ASTM C 361).

701-2.6

DELETE: This section.

CONSTRUCTION METHODS

701-3.3 CRADLE

REPLACE all references to "Item 208-2.3" with "Item 208-2.2" in this section.

701-3.7 BACKFILLING

ADD:

At the locations shown on the plans (existing, proposed and future paved areas), the trench excavation shall be backfilled with select granular backfill materials. The material shall meet the requirements set forth for granular cradle for dry trench conditions as set forth in Section 701-3.3 "CRADLE". Selected granular backfill materials shall be compacted in lifts no greater than 6" thick to 95% of the maximum density in accordance with ASTM D-698, Method C or D (Standard Proctor). Pipe replacement must be visually inspected before backfilling.

701-3.12 SEQUENCING OPERATIONS AND MAINTAINING DRAINAGE

ADD:

A minimum separation of 18" shall be observed when crossing proposed watermain with the existing utility. Replacement of the existing utility pipe is to be made to establish an integral connection and provide protection between the existing utility and proposed watermain.

701-3.13 PIPE REMOVAL

ADD:

The Contractor shall remove the existing pipe and dispose off of Airport property. Pipe removal under proposed pavement areas shall be backfilled per Section 701-3.7. Openings due to pipe removals at existing drainage structures to remain shall be patched with brick and mortar as directed by the Engineer.

METHOD OF MEASUREMENT

701-4.4

The volume of selected granular backfill shall be measured for payment. Measurement shall be computed by multiplying the actual length by actual width, up to the maximum trench width shown on the plans. Deductions for the installed pipe area will be made as well. Granular cradle for the pipe will not be measured for payment.

BASIS OF PAYMENT

701-5.1

ADD:

Payment will be made under:

ITEM AR701512 12" RCP, CLASS IV – PER LINEAL FOOT.

ITEM AR701830 TRENCH BACKFILL – PER CUBIC YARD.

ITEM AR701900 REMOVE PIPE – PER LINEAL FOOT.

DIVISION V - TURFING

ITEM 901 - SEEDING

DESCRIPTION

901-1.1

DELETE: This section in the Supplemental Specifications.

ADD:

This item shall consist of seeding and fertilizing the proposed improvement areas as designated on the plans, miscellaneous grading areas and any areas disturbed as a result of the Contractor's operations

MATERIALS

901-2.1 SEED

REVISE: The second sentence in the second paragraph in the Standard Specifications to read:

The contractor shall furnish the Resident Engineer duplicate signed copies of a statement by a recognized laboratory for seed testing within one year of the date of delivery.

DELETE: This section in the Supplemental Specifications.

ADD:

The seed mixtures shall be as follows:

SEEDING CLASS 1 – LAWN MIXTURES

<u>SEEDS</u>	<u>LBS/ACRE</u>
KY Bluegrass	100
Perennial Ryegrass	60
Creeping Red Fescue	40
TOTAL	<u>200</u>

Alternate seed mixtures may be submitted for consideration by the Engineer.

901-2.2 LIME

DELETE: This Section in the Standard and Supplemental Specifications.

901-2.3 FERTILIZER

DELETE: This section in the Supplemental Specifications.

REVISE last paragraph to read as follows:

Fertilizer shall be applied at rates that supply the following amounts of nutrients per acre to the distributed areas of seeding:

<u>NUTRIENTS</u>	<u>POUNDS PER ACRE</u>
Nitrogen	90
Phosphorus (P ₂ O ₅)	90
Potassium (K ₂ O)	90
TOTAL	<u>270</u>

CONSTRUCTION METHODS

901-3.2 DRY APPLICATION METHOD

DELETE: Entire Section

ADD:

(a) Description: This work shall consist of furnishing, transporting and installing all seeds, plant or other materials required for:

1. Any remedial operations in conformance with the plans as specified in these special provisions or as directed by the Engineer.

(b) General Requirements: The site will be in the following condition:

1. The grade will be shaped to the elevation shown on the plans.
2. The topsoil will be free of clods, stones, roots, sticks, rivulets, gullies, crusting, caking and have a soil particle size of no larger than 1".

(c) Seeding Equipment: Seeding equipment shall meet the following requirements. Any other equipment deemed necessary shall be subject to the approval of the Engineer.

1. Disc: Any disc proposed for the use shall be in a good state of repair with sound, unbroken blades. The disc shall be weighted if necessary to achieve the required tillage depth.
2. No-Till Planters and Drills: Rangeland type drills and no-till planters shall be designed specifically for the seeding of native grasses and forbs with depth control bands set at 1/4" - 1/8".
3. Seedbed Preparation: Seedbed preparation methods shall be approved by the Engineer. Cultivation shall be accomplished at such a time that seeding may occur immediately and without delay. No seeds shall be sown until the Seedbed has been approved by the Engineer.

(d) Seeding Methods: The Contractor shall submit for approval by the Engineer and schedule for seeding and/or planting at least two weeks prior to the scheduled commencement of work. Broadcast seeders will not be allowed. Seeder will be a drill type planters. The Engineer shall examine and then approve any equipment to be used. Prior to starting work, all seeding equipment shall be calibrated and adjusted to sow seeds at the proper seeding rate. Equipment shall be operated in a manner to insure complete coverage of the entire area to be seeded. The Engineer shall be notified 48 hours prior to beginning the seeding operations. Any gaps between areas of growth greater than eight square feet shall be resown and/or replanted.

1. No-till or Drill Method: Rolling of the Seedbed will not be required with the use of rangeland type grass drill or no-till planters.

METHOD OF MEASUREMENT

901-4.1

ADD:

Areas of seeding not showing a uniform stand of grass in density and color shall not be approved for payment. Such areas shall be reseeded to the Owner's satisfaction at the Contractor's cost.

ITEM 905 - TOPSOILING

DELETE the SUPPLEMENTAL SPECIFICATION and REPLACE with the following:

DESCRIPTION

905-1.1

ADD:

This item shall consist of a 4" layer of topsoil placed throughout the site as shown on the plans. In addition, the surface of all disturbed areas shall be covered with a layer of topsoil, as needed, to facilitate drainage and the growth of turf.

Topsoil shall be supplied by the Contractor from outside the boundaries of the Airport property. It shall be the Contractor's responsibility to locate and obtain the supply, subject to the approval of the Engineer. The Contractor shall notify the Resident Engineer sufficiently in advance of the beginning of excavation, so necessary tests can be made.

CONSTRUCTION METHODS

905-3.4 PLACING TOPSOIL

Rutted or damaged areas due to construction and other areas graded as a part of this contract shall have topsoil spread as required to facilitate drainage and turfing. Thickness of the topsoil shall be as shown on the plans.

METHOD OF MEASUREMENT

905-4.1

DELETE: This section.

ADD:

Topsoiling paid for shall be the number of square yards measured at the locations shown in the plans or as directed by the Engineer. No Measurement for payment shall be made for supplying topsoil from offsite source, spreading and excavation associated with this item.

Areas that required topsoiling due to the Contractor rutting and disturbing the areas outside of the limits shown on the plans will not be measured for payment, but shall be considered incidental.

BASIS OF PAYMENT

905-5.3

Payment shall be made at the contract unit price per square yard for TOPSOILING. This price shall be full compensation for topsoil stripping, stockpiling and spreading, excavation and for furnishing all materials, labor, equipment, tools and incidentals necessary to complete the item

Payment will be made under:

ITEM AR905530 TOPSOILING – PER SQUARE YARD.

DIVISION VIII - MISCELLANEOUS

ITEM 156000 - EROSION CONTROL

MATERIALS

156-2.6 EROSION CONTROL BLANKET

Excelsior blanket shall consist of a machine produced mat of wood excelsior of 80 percent 6 inches or longer fiber length. The wood from which the excelsior is cut shall be properly cured to achieve adequately curled and barbed fibers.

The blanket shall be of consistent thickness, with the fiber evenly distributed over the entire area of the blanket. The excelsior blanket shall be covered on the top side with a 90 day biodegradable extruded plastic mesh netting having an approximate minimum opening of 16 x 16 mm (5/8 x 5/8") to an approximate maximum opening of 50 x 25 mm (2 x 1"). The netting shall be entwined with the excelsior mat for maximum strength and ease of handling.

The excelsior blanket shall comply with the following Specifications:

Minimum width, inches, minus 1 inch	24
Minimum weight per square yard, pounds, minus 10 percent	0.8
Minimum length of roll, feet, approximately	150

The excelsior blanket shall be smolder resistant and shall withstand the following test. The excelsior blanket specimen shall not flame or smolder for more than a distance of 12 inches from a spot where a lighted cigarette is placed on the surface of the blanket.

Certification. The manufacturer shall furnish a certification with each shipment of blanket stating the number of rolls furnished and that the material complies with the requirements of the Specifications.

156-2.7 STAKES FOR EROSION CONTROL BLANKET

The blanket shall be secured with biodegradable stakes acceptable to the Engineer. Metal staples will not be allowed.

CONSTRUCTION METHODS

156-3.10

In the event that temporary erosion and pollution control measures are ordered by the Engineer due to the Contractor's negligence or carelessness, the work shall be performed by the Contractor at no additional cost to the Owner.

156-3.11 EROSION CONTROL BLANKET

Within 24 hours from the time seeding has been performed, the blanket shall be placed. Prior to placing the mat or blanket, the areas to be covered shall be relatively free of all rocks or clods over 1-½ inches in diameter, and all sticks or other foreign material, which will prevent the close contact of the mat or blanket with the seedbed. If as a result of a rain, the prepared seed bed becomes crusted or eroded, or if the eroded places, ruts or depressions exist for any reason, the Contractor will be required to rework the soil until it is smooth and to reseed such areas which are reworked. After the area has been properly shaped, fertilized and seeded, the mat or blanket shall be laid out flat, evenly and smoothly, without stretching the material.

The blanket shall be laid in accordance with the manufacturer's recommendations. All ends and edges shall be tightly butted together.

The blanket shall be held in place by means of stakes. The stakes shall be driven at a 90 degree angle to the plane of the soil. Stakes shall be spaced not more than 3 feet apart in 3 rows for each strip, with a row along each edge

and one row alternately spaced in the middle. All ends shall be fastened by stakes spaced 6 inches apart across the width.

Once turf growth has been established, all non-biodegradable components shall be removed by the contractor. This would include any item that would interfere with the mowing of the new turf or which might damage mowing equipment. Furthermore, the contractor shall fill with topsoil or smoothly grade any ruts or gullies which developed during the turf grow in period to the satisfaction of the Owner. This work shall be considered incidental to this item.

METHOD OF MEASUREMENT

156-4.2

REVISE This section to read as follows:

Erosion control blanket shall be the number of square yards satisfactorily completed.

BASIS OF PAYMENT

156-5.1

DELETE: This section.

ADD:

Payment shall be made at the contract unit prices of respective erosion control devices installed on the project. These prices shall be full compensation for furnishing all materials, labor, equipment and any incidentals necessary to install and **maintain** the erosion control devices shown on the plans and specified herein.

156-5.2

This price shall be full compensation for furnishing all materials, for all preparation and installation of these materials, including excavation, placement, tie-down stakes, maintenance and removal and for all labor equipment, tools and incidentals necessary to complete this item.

Payment will be made under:

ITEM AR156531 EROSION CONTROL BLANKET – PER SQUARE YARD.

ITEM 760 - WATERMAIN

DESCRIPTION

760-1.1

The Contractor shall furnish and install the proposed ductile iron pipe of the diameter specified at the locations shown on the plans. The ductile iron pipe shall include excavation, granular bedding, installation of the ductile iron pipe, polyethylene wrap, cement lined ductile iron fittings, testing and chlorination of the ductile iron pipe and all incidental work required for a complete and operational piping system.

Trench backfill will not be incidental to this item but shall be measured for payment under the Item AR701830 TRENCH BACKFILL.

Polyethylene encasement and taping of all joints shall be installed for all buried and cased ductile iron pipe piping, fittings and valves as shown on the plans.

This item shall consist of furnishing fire hydrants and auxiliary valves with valve boxes and installing them at the locations shown on the drawings and in accordance with the Aqua Illinois Standard Notes and Details shown in the plans and the Standard Specifications for Water and Sewer Main Construction in Illinois, Fifth Edition.

This item shall consist of furnishing gate valves with valve boxes and installing them at the locations shown on the drawings and in accordance with the Standard Specifications for Water and Sewer Main Construction in Illinois, Fifth Edition.

MATERIALS

760-2.1 DUCTILE IRON PIPE

Ductile iron pipe shall be cement-mortar lined per ANSI A21.4 (AWWA C-104), ductile iron pipe, push-on type, conforming to the requirements of ANSI specification A21.51 (AWWA C-151) Class 52 (pressure class of 350 psi). Nominal thickness for Class 52 8" pipe: T=0.33 and for 6" pipe: T=0.31.

Sections of ductile iron pipe shall be connected by means of push-on joints consisting of bells cast integrally with the pipe, which have interior angular recesses conforming to the shape and dimension of a rubber sealed gasket. The interior dimensions of which is such that it will admit the insertion of the spigot end of the joining pipe in a manner that will compress the gasket tightly between the bell of the pipe and the inserted spigot, thus securing the gasket and sealing the joint. Joints shall conform to the requirements of AWWA C-153.

The lubricant used in conjunction with the push-on joints shall be of material that is recommended by the suppliers, or an acceptable commercially processed animal fat or vegetable shortening.

Megalug glands shall be installed at mechanical joints and shall be incidental to the cost of the pipe.

760-2.2 BEDDING

Bedding shall meet the IDOT CA-11 gradation unless otherwise approved by the Engineer. The bedding shall be mechanically tamped into place.

760-2.3 BACKFILL

The material used for trench backfill shall be aggregate meeting the requirements of IDOT CA-6 gradation set forth in Item 208 and 701.

760-2.4 FIRE HYDRANT

Fire hydrants shall be Mueller Super Centurion 200, U.S. Pipe. Each hydrant shall be compression type, open with pressure in a counterclockwise direction with rising stem, have a traffic flange and meet or exceed AWWA specification C502.

Each hydrant shall be provided with a drain that will leave no water standing in the barrel of the hydrant when the hydrant is closed. This drain shall close tightly before the hydrant begins to open. The hose and pumper connections shall be securely leaded and locked into the hydrant and each shall be provided with a suitable cast iron threaded cover securely attached to the hydrant by a steel chain.

Fire hydrants shall be designed to withstand, without leaking or damage to the hydrant, a hydraulic pressure of 300 pounds per square inch and an operating pressure of 200 pounds per square inch.

All fire hydrants shall be supplied painted with two coats of Tnemec brand Tnemec Gloss Federal Safety Yellow Enamel #2016 (OSHA 1910.44-ANSI 53.1).

Mechanical joint anchoring tees shall be used for the auxiliary connection to the water main. The auxiliary valve shall be manufactured from US Pipe, Clow, Waterous, American Flow Control or equal. The valve shall meet AWWA C509 standards for resilient seated wedge gate valves. The valves shall be 6" in size, open to the left (counter clockwise) and shall have mechanical joint ends with Mega-Lug restrained joints or equal. Gate valves installed in fire hydrant leads shall have "O" ring stuffing box. Stem, indicators, and all working parts shall be fully protected from moisture or weather damage by complete enclosure. Operating stem shall be bronze and nuts shall be two inches square.

Connection of the auxiliary valve to the fire hydrant shall be completed utilizing a 6" diameter Clow MJ Anchoring coupling or equal for laying distances of 12" to 18". For longer distances, use Class 52 ductile iron pipe with Megalug or equal retainer glands. Cover for the auxiliary valve shall be painted with Tnemec brand Tnemec Gloss

Federal Safety Blue #2045 (OSHA 1910.144-ANSI 53.1).

A cast iron adjustable valve box shall be furnished with each valve along with an extension stem to allow the operating nut to be within 12" of the surface. Provide one tee wrench for each three valves. Valve boxes shall be Tyler Cast Iron Valve Box 6645 or equal. Valve boxes shall be provided with Polycarbonate Rigid Valve Box Stabilizers as manufactured by Valve Box Stabilizer Co., Joliet, IL or equal.

760-2.5 IRON FITTINGS

Fittings shall be cement lined, tar coated ductile iron with mechanical rubber gasketed joints rated 350 psi per AWWA C-110/ANSI 21.20. (American, U.S. Pipe, Tyler, Griffen or equal). All fittings shall incorporate retainer glands. All Retainer Glands shall be Tyler or Mueller Class 350 Mechanical Joints with Megalugs or equal.

760-2.6 POLYETHYLENE WRAP

The water main shall be wrapped in 8 mil. thick (minimum) polyethylene wrap in accordance with AWWA C105/A21.55-82 suitable for the appropriate diameter of pipe.

760-2.7 GATE VALVES

Gate valves shall meet the latest revision of AWWA C509. Gate valves shall open to the left (counter clockwise) and shall have mechanical joints. Gate valves shall have resilient seats. Gate valves shall be Clow MJ Resilient Wedge or Mueller MJ Resilient Seat.

A cast iron adjustable valve box shall be furnished with each valve along with an extension stem to allow the operating nut to be within 12" of the surface. Provide one tee wrench for each three valves. Valve boxes shall be Tyler Cast Iron Valve Box 6645 or equal. Valve boxes shall be provided with Polycarbonate Rigid Valve Box Stabilizers as manufactured by Valve Box Stabilizer Co., Joliet, IL or equal.

760-2.8 VALVE VAULT

Vaults shall be precast concrete manufactured in conformance with ASTM C478 with concentric cones and joints sealed with Rubber-NEC or approved butyl based material. Cement grouting of the seams and joints will not be allowed. Concrete adjustment rings cannot exceed 8" in height. Manhole casting shall be IDOT Type 1 closed lid with the words "Water" printed on it. Lid shall be Neenah Foundry Type B self sealing lid or equal.

A flexible union between the pipe and the manhole wall, meeting ASTM C923, cast integrally into the manhole wall shall be provided for each pipe connection to the manhole. Flexible boots shall be Interpace Lock Joint Flexible Manhole Sleeve, A-Lok Manhole Pipe Connector, Link Seal or equal and shall be installed in accordance with the manufacturer's recommendations.

CONSTRUCTION METHODS

760-3.1 DUCTILE IRON PIPE INSTALLATION

The ductile iron pipe shall be installed as detailed on the plans and in accordance with the Aqua Illinois Standard Notes and Details shown in the plans and the applicable provisions of the "Standard Specifications for Water and Sewer Main Construction in Illinois" (latest edition). The ductile iron pipe shall be installed to the grades shown on the plans and shall have a nominal minimum depth of cover of five feet six inches (5'-6") from proposed, future or existing grades.

The Contractor shall excavate under the ductile iron pipe bells to assure uniform bearing of the pipe on the bottom of the trench. Granular bedding shall be placed along the entire length of all ductile iron pipe from six (6) inches below ductile iron pipe to the spring line of the pipe. The bedding material shall be incidental to the ductile iron pipe.

If the excavation has been made deeper than necessary, the ductile iron pipe shall be laid at the lower depth, and no additional cost shall be charged to the OWNER for the extra excavation, or for subsequent adjustments to fire hydrants, valve vaults or services. All excavated materials not needed for backfilling the trenches shall be disposed of by the Contractor.

Water in the trench shall be removed during pipe laying and jointing operations. This cost shall be considered incidental to the water main. Provisions shall be made to prevent floating of the pipe. Trench water shall not be allowed to enter the pipe at any time.

Adequate provisions shall be made for safely storing and protecting all water pipe prior to the actual installation in the trench. Care shall be taken to prevent damage to the pipe castings, both inside and out. Provisions shall be made to keep the inside of the pipe clean throughout its storage period and to keep mud and/or debris from being deposited therein.

All water main crossings shall be in accordance with IEPA separation requirements. Where a water main must cross above an existing sanitary or storm sewer, the invert of the water main shall be a minimum of 18" above the crown of the sewer for at least 10 feet each side of the crossing. Where proper vertical separation is not obtainable the water main shall be encased in steel casing pipe to 10 feet either side of the sewer crossing. The casing pipe shall be 6" greater than the bell diameter of the water main. In lieu of casing the water main, the Contractor could replace the sewer line at least 10' on either side of the crossing with prestressed concrete pipe in conformance with Section AR701.

Where a water main must cross below an existing sanitary or storm sewer, the crown of the water main shall be a minimum of 18" below the invert of the sewer or the sewer shall be replaced with watermain-quality pipe.

All pipe shall be thoroughly cleaned on the inside before laying. Proper equipment shall be used for the safe handling, conveying and laying of the pipe. All pipe shall be carefully lowered into the trench, piece by piece, by means of suitable tools or equipment, in such a manner as to prevent damage to water main materials and protective coatings and linings. Under no circumstances shall water main material be dropped or dumped into the trench.

The pipe shall be inspected for defects. All lumps, blisters and excess coal tar coating shall be removed from the ends of each pipe, and the inside of the bell.

When connecting joints, all portions of the joining materials and the socket and spigot ends of the joining pipe shall be wiped clean of all foreign materials. The actual assembly of the joint shall be in accordance with the manufacturer's installation instructions. During the construction and until joining operations are complete, the open ends of all pipes shall be at all times protected and sealed with temporary water tight plugs.

The entire section of the pipe shall be pushed forward to seat the spigot end into the bell. After the section of pipe is inserted into the bell (when joining pipe to mechanical joint fittings) the gasket shall then be pressed into place within the bell, being careful to have the gasket evenly located around the entire joint.

760-3.2 BACKFILL

All trenches in the locations described above shall be backfilled with trench backfill to a point not less than two (2) feet from the outside edges of existing and proposed pavement and one (1) foot from the outside edges of existing and proposed sidewalk.

Non-paved areas shall be backfilled from the springline with originally excavated material free from rocks, frozen material or large clods and shall be carefully placed and compacted to prevent damage to or the dislodging of the ductile iron pipe. The trench shall be mechanically compacted to 90% of the Standard Proctor in accordance with ASTM D698 (maximum of 6" lifts).

In paved areas, trench backfill (from the springline of the pipe to the proposed subgrade) shall be constructed in accordance with the applicable sections of the Specification and paid for under Item AR701830 TRENCH BACKFILL. Backfilling of all trenches in paved areas shall be compacted by mechanical compaction in no greater than 6" lifts to a minimum of 95% of the Standard Proctor Density in accordance with ASTM D698.

760-3.3 TESTING

The Contractor shall notify Aqua Illinois and the Resident Engineer 5 working days in advance of the testing. An Aqua Illinois representative along with the Resident Engineer shall be present at all testing.

Contractor shall pressure test by filling the pipe with clean water under a minimum hydrostatic pressure of two hundred (200) pounds per square inch for two (2) hours. The testing shall be in conformance with Section 41-2.13 of the "Standard Specifications for Water and Sewer Main Construction in Illinois," Latest Edition.

After completion of the pressure test the Contractor shall conduct a leakage test to determine the quantity of water lost by leakage under the specified test pressure. The leakage test shall be in conformance with Section 41-2.13C of the "Standard Specifications for Water and Sewer Main Construction in Illinois," Latest.

When pressure and leakage tests are completed, accepted and prior to being placed into service, the ductile iron pipe and appurtenances shall be disinfected by a method of chlorination approved by the Aqua Illinois and the Resident Engineer.

Disinfection of the ductile iron pipe shall conform to Section 41-2.14 of the "Standard Specifications for Water and Sewer Main Construction in Illinois," Latest Edition and per the requirements of Aqua Illinois.

Any defects, cracks or leakage that may develop or may be discovered, either in the joints or in the body of the castings, shall be promptly repaired by the Contractor at his own expense.

All watermains shall be satisfactorily disinfected prior to use. In accordance with the requirements of AWWA C651-99, at least one set of samples shall be collected from every 1,200 feet of new watermain, plus one set from the end of the line and at least one set from each branch. Satisfactory disinfectant shall be demonstrated in accordance with the requirements of 35 Ill. Adm. Code 652.203.

760-3.4 FIRE HYDRANTS AND AUXILIARY VALVES

Each hydrant shall be set on a flat stone not less than 24 inches by 24 inches by 4 inches in thickness. A minimum of 3/4 cubic yard of gravel shall be placed around the base of the hydrant in order to provide drainage for the hydrant drain.

All hydrants shall be set plumb and shall have their nozzles parallel with edge of pavement, the pumper connection shall be facing the edge of pavement. Hydrants shall be set to the established grade, with nozzles eighteen (18") inches above the ground or as directed by the OWNER.

All excavation around the fire hydrant and auxiliary valve shall be backfilled to the natural line or finished grade as rapidly as possible. The backfill material shall consist of the excavated material or trench backfill as herein specified. All backfill material shall be deposited in the excavation in a manner that will not cause damage to the fire hydrant or auxiliary valve. Any depressions which may develop within the area involved in a construction operation due to settlement of backfill material shall be filled in a manner consistent with standard practice.

The fittings, piping and valves for the hydrant shall be provided with restrained joints in addition to a thrust block behind the base elbow.

Valve shall be installed plumb and on solid bearing. Set valve box cover flush with finish grade.

760-3.5 IRON FITTINGS

The Contractor shall install ductile iron pipe fittings in accordance with the drawings, the requirements stated herein, and the applicable construction requirements of Division IV of the "Standard Specifications for Water and Sewer Main Construction in Illinois", as follows:

DIVISION IV WATER DISTRIBUTION

Section 40 Pipe for Water Main and Service Connections

Section 41 Pipe for Installation for Water Mains

All fittings which deflect the flow 11-1/4 degrees or greater shall have a thrust block. Thrust blocks shall be poured concrete of the dimensions shown on the drawings and in accordance with the provisions of the "Standard Specifications for Water and Sewer Main Construction in Illinois". Fittings shall be installed with "Megalug" brand retaining glands or equal.

760-3.6 POLYETHYLENE WRAP

The pipe shall be installed in polyethylene encasement in accordance with the installation guidelines in AWWA specifications C105/A21.5-93 and as detailed on the plans.

All fittings shall be wrapped with two layers of polyethylene film which shall be clean and free of soil and aggregates. The film shall not be punctured, streaked or damaged during installation and backfilling otherwise the Contractor shall replace the two layers of film at his own expense.

760-3.8 GATE VALVES

Valves shall be installed at the location shown on the plans, as stated herein and in accordance with the manufacturer's recommendations. Valve shall be installed plumb and on solid bearing. Set valve box cover flush with finish grade.

760-3.9 VALVE VAULT

Vaults shall be constructed with a precast base section or monolithic base structure as shown on the plans on a compacted 6" sand cushion. All lift holes on precast elements shall be thoroughly wetted and filled with non shrink grout, smoothed inside and out. The first barrel section shall be uniformly supported by the base concrete and shall not bear directly on any of the pipes. Castings shall be set in butyl rope. The space between the pipe and the wall shall be completely filled with non-shrink grout and sealed watertight.

No more than 8" maximum concrete adjusting rings may be utilized to meet the grades specified.

METHOD OF MEASUREMENT

760-4.1

Ductile iron pipe will be measured per lineal foot along the centerline of the water main from the center of the valve to the center of the valve, fittings or end of pipe; installed, ready for use and accepted by the Engineer.

Fire hydrants and auxiliary valves and valve boxes will be measured per each installed, ready for use and accepted by the Engineer. No direct measurement for fittings and 6" lead water main shall be made.

The polyethylene wrap, fittings and bedding shall not be measured separately, but shall be considered incidental to the construction of the water main pipe.

The volume of trench backfill shall be measured for payment. Measurement shall be computed by multiplying the actual length by actual width, up to the maximum trench width shown on the plans. Deductions for the installed pipe area will be made as well. Granular cradle for the pipe will not be measured for payment.

Gate Valve and Box shall be measured per each WATER VALVE installed and approved by the Resident Engineer.

Valve Vault shall be measured per each VALVE VAULT installed and approved by the Resident Engineer.

BASIS FOR PAYMENT

760-5.1

Excavation, bedding, installation of ductile iron pipe, connections, compaction, pressure testing, chlorination shall be included and paid for on a water main per lineal foot basis. Said price shall include all labor materials, equipment and incidentals as shown on the plans and as specified herein to construct a complete and operational piping system.

Payment for iron fittings shall be considered incidental to the proposed water main. This item shall also include all work associated with construction of the thrust blocks and connections to existing water main.

No direct payment will be made for Polyethylene Wrap. The cost of furnishing and installing Polyethylene Wrap shall be considered incidental to the contract unit prices for the respective pay items utilizing the Polyethylene Wrap. These prices shall be full compensation for furnishing all materials and for all preparation, delivering and installation of these materials, and for all labor, equipment and incidentals necessary to complete the item.

Trench backfill will not be incidental to this item but shall be measured for payment under Item AR701830 TRENCH BACKFILL. The bedding material shall be incidental to the water main.

Fire hydrants and auxiliary valves and valve boxes shall be paid for on a per each basis installed as a complete operational unit including any granular backfill, 6" water main, rods, valves, restrained joints, thrust blocks, flat stone and concrete used to complete the item.

Payment for gate valves and box shall be made at the contract unit price per each bid for AR760830 WATER VALVE. Payment shall be full compensation for excavation, bedding, installation and all labor, materials, equipment and incidentals as shown on the plans and as specified herein.

Payment for valve vaults shall be made at the contract unit price per each bid for AR760850 VALVE VAULT. Payment shall be full compensation for excavation, bedding, installation and all labor, materials, equipment and incidentals as shown on the plans and as specified herein.

Payment will be made under:

- ITEM AR760504 4" DUCTILE IRON WATER MAIN – PER LINEAL FOOT.
- ITEM AR760508 8" DUCTILE IRON WATER MAIN – PER LINEAL FOOT.
- ITEM AR760800 FIRE HYDRANT – PER EACH.
- ITEM AR760830 WATER VALVE – PER EACH.
- ITEM AR760850 VALVE VAULT – PER EACH.

ITEM 770 SANITARY SEWER

DESCRIPTION

770-1.1

Under this item, the Contractor shall provide all labor, equipment and materials necessary to construct the sanitary sewer as shown on the plans.

Select granular backfill will not be incidental to this item but shall be measured for payment under the Item AR701830 TRENCH BACKFILL.

MATERIALS

770-2.1 PIPE

PVC sanitary sewer pipe 6" - 15" diameter shall meet ASTM D-1784 or AWWA C900 with a minimum SDR of 26. Joints shall meet ASTM F-477 and ASTM D-3139.

770-2.2 BEDDING

The material for bedding shall be crushed stone and shall meet the IDOT CA-11 gradation.

770-2.3 BACKFILL

If installed beneath future, existing or proposed pavement, the material used for select granular backfill shall be aggregate meeting the requirements of IDOT CA-6 gradation set forth in Items 208 and 701. If installed beneath turf, backfill shall consist of original excavated material.

CONSTRUCTION METHODS

770-3.1 PIPE

Pipe shall be installed to the line and grades shown on the plans. Mud, silt, gravel and other foreign material shall be kept out of the pipe and off the jointing surfaces.

All pipe laid shall be retained in position so as to maintain alignment and joint closure until sufficient backfill has been completed to adequately hold the pipe in place. All pipe shall be laid to conform to the prescribed line and grade shown on the plans, with the limits that follow. At least three batterboards shall be maintained in position

during all pipe laying operations, unless a laser beam is used.

Variance from established line and grade shall not be greater than one thirty-second (1/32) of an inch per inch of pipe diameter and not to exceed one-half (1/2) inch, provided that any such variation does not result in a level or reverse sloping invert; provided also, that variation in the invert elevation between adjoining ends of pipe, due to non-concentricity of joining surface and pipe interior surfaces, does not exceed one sixty-fourth (1/64) per inch of pipe diameter, or one-half (1/2) inch maximum.

The sewer pipe, shall be laid up grade from point of connection on the existing sewer. The sewer pipe shall be installed with the bell end forward or up-grade. When pipe laying is not in progress the forward end of the pipe shall be kept tightly closed with a temporary plug.

Pipe handling after the gasket has been affixed shall be carefully controlled to avoid disturbing the gasket and knocking it out of position or loading it with dirt or other foreign material. Any gaskets so disturbed shall be removed and replaced, cleaned and relubricated if required, before the jointing is attempted.

Care shall be taken to properly align the pipe before the joints are entirely forced home. During insertion of the tongue or spigot, the pipe shall be partially supported by hand, sling or crane to minimize unequal lateral pressure on the gasket and to maintain concentricity until the gasket is properly positioned.

Sufficient pressure shall be applied in making the joint to assure that it is home, as described in the installation instructions provided by the pipe manufacturer. Sufficient restraint shall be applied to the line to assure that joints once home are held so, until fill material under and alongside the pipe has been sufficiently compacted. At the end of the work day, the last pipe laid shall be blocked in an effective way to prevent creep "down time."

770-3.2 BEDDING

The pipe bedding shall be placed so that the entire length of the pipe will have full bearing. No blocking of any kind shall be used to adjust the pipe to grade except when used with concrete encasement.

770-3.2 BACKFILL

All trenches in the locations described above shall be backfilled with selected granular backfill to a point not less than two (2) feet from the outside edges of existing and proposed pavement and one (1) foot from the outside edges of existing and proposed sidewalk.

Non-paved areas shall be backfilled from the springline with originally excavated material free from rocks, frozen material or large clods and shall be carefully placed and compacted to prevent damage to or the dislodging of the ductile iron pipe. The trench shall be mechanically compacted to 90% of the Standard Proctor in accordance with ASTM D698 (maximum of 6" lifts). Backfilling with the originally excavated material shall be incidental to the sewer.

In paved areas, select granular backfill (from the springline of the pipe to the proposed subgrade) shall be constructed in accordance with the applicable sections of the Specification and paid for under Item AR701830 TRENCH BACKFILL. Backfilling of all trenches in paved areas shall be compacted by mechanical compaction in no greater than 6" lifts to a minimum of 95% of the Standard Proctor Density in accordance with ASTM 698.

770-3.4 LAYOUT

The Contractor shall constantly check line and grade of the laser beam and the pipe and in the event they do not meet specified limits described hereinafter, the work shall be immediately stopped, the Engineer notified, and the cause remedied before proceeding with the work.

770-3.5 DEWATERING

Dewatering - Dewatering sufficient to maintain the water level 12 inches below the surface of the trench bottom or base of the bedding course, shall be accomplished prior to pipe laying and jointing, if not prior to excavation and placing of the bedding as called for in other sections of the specifications or Special Provisions. The dewatering operation, however accomplished, shall be carried out so that it does not destroy or weaken the strength of the soil under or alongside the trench. The normal water table shall be restored to its natural level in such a manner as to not disturb the pipe and its foundation.

METHOD OF MEASUREMENT

770-4.1

Sanitary sewer will be measured by the lineal foot in place for the diameter and type of pipe indicated. Sanitary sewer shall be measured along the centerline of the pipe to the center of the wall of each manhole or connection. All bedding shall be incidental to this item.

BASIS OF PAYMENT

770-5.1

Payment for sanitary sewer shall be made at the contract unit price per lineal foot bid for SANITARY SEWER of the appropriate diameter and depth. Payment shall be full compensation for excavation, bedding, installation of sewer, testing and televising, and all labor, materials, equipment as shown on the plans and as specified herein to provide a complete and operational sanitary sewer.

Select granular backfill will be incidental to this item and shall not be measured for payment. Bedding material shall also be incidental to the sanitary sewer.

Select granular backfill will not be incidental to this item but shall be measured for payment under Item AR701830 TRENCH BACKFILL. Backfilling with the originally excavated material shall be incidental to the sewer. The bedding material shall be incidental to the sewer.

Payment will be made under:

ITEM AR770506 6" SANITARY SEWER – PER LINEAL FOOT.

ITEM 800019 – FRESH WATER WELL ABANDONMENT

DESCRIPTION

800019-1.1

This work shall consist of the location, abandonment and/or plugging of any fresh water well located on the demolition site, as shown on the plans in accordance with all federal, state and local rules and regulations. **This work shall conform to Section 920.120 Abandoned Wells of the Illinois Water Well Construction Code by the Illinois Department of Health.**

800019-1.2

This work shall also include the Contractor's filing for and subsequent obtaining of all permits required for the said well abandonment.

MATERIALS

800019-2.1

All materials used in the performance of this work shall comply with all federal, state and local rules and regulations. Plugging material shall be neat cement containing bentonite, aquagel, or similar materials from 2% to 6%. Bentonite will also be allowed as a suitable plug material. For the porous zone of the well the material shall be a sterile porous material such as pea-gravel.

CONSTRUCTION METHODS

800019-3.1

The Contractor shall locate and abandon all fresh water wells as specified herein. All connecting water lines and electrical facilities shall be disconnected, sealed or removed in conformance with applicable local ordinances and to the satisfaction of the Engineer. All adjacent concrete structures or pads shall be removed. No additional payment shall be made for concrete removal associated with the abandonment of a well. The plug shall begin at the top of the water bearing formation and be a minimum of 10'. A bentonite slurry, or impervious material shall be used to fill the upper part of the well. The casing shall be removed to at least 3 feet below final grade.

METHOD OF MEASUREMENT

800019-4.1

The number of abandoned wells shall be counted and measured by the completed unit.

BASIS OF PAYMENT

800019-5.1

Payment shall be made at the contract unit price per each for ABANDONMENT OF FRESH WATER WELLS. This price shall be full compensation for furnishing all materials, labor, equipment and for any preparation including any excavation and backfill, as well as any incidentals necessary to complete the item as shown on the plans and as specified herein.

Payment will be made under:

ITEM AR800019 FRESH WATER WELL ABANDONMENT

PER EACH

IDOT STANDARD DETAILS

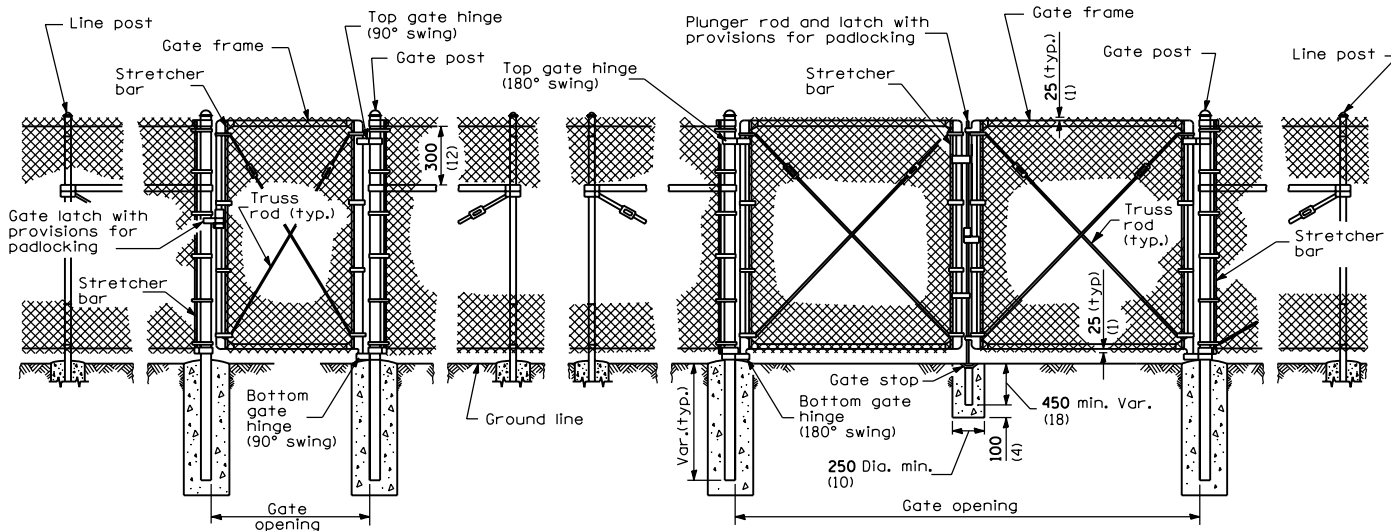

PEDESTRIAN GATE ARRANGEMENT

VEHICLE GATE ARRANGEMENT

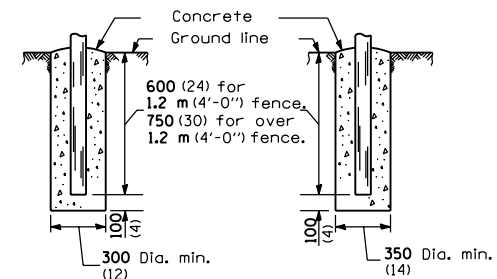

FOOTING FOR LINE POST

FOOTING FOR GATE & TERMINAL POST

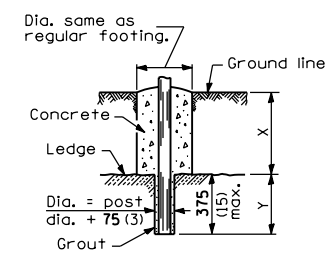

FOOTING FOR POST IN ROCK LEDGE

GENERAL NOTES

Pull posts shall be placed at locations determined by the Engineer. They shall be placed at 200 m (660') intervals between posts to which the ends of the fabric are clamped or midway between such posts when the distance is less than 400 m (1320') and greater than 200 m (660').

X + Y shall not exceed 600 mm (24"), 750 mm (30") or 900 mm (36"), as applicable. When X is 0 (0) to 225 mm (9"), 380 mm (15"), or 525 mm (21"), Y = 375 mm (15"), and the post shall be shortened as required. When X exceeds 225 mm (9"), 380 mm (15"), or 525 mm (21"), Y shall be decreased correspondingly.

All dimensions are in millimeters (inches) unless otherwise shown.

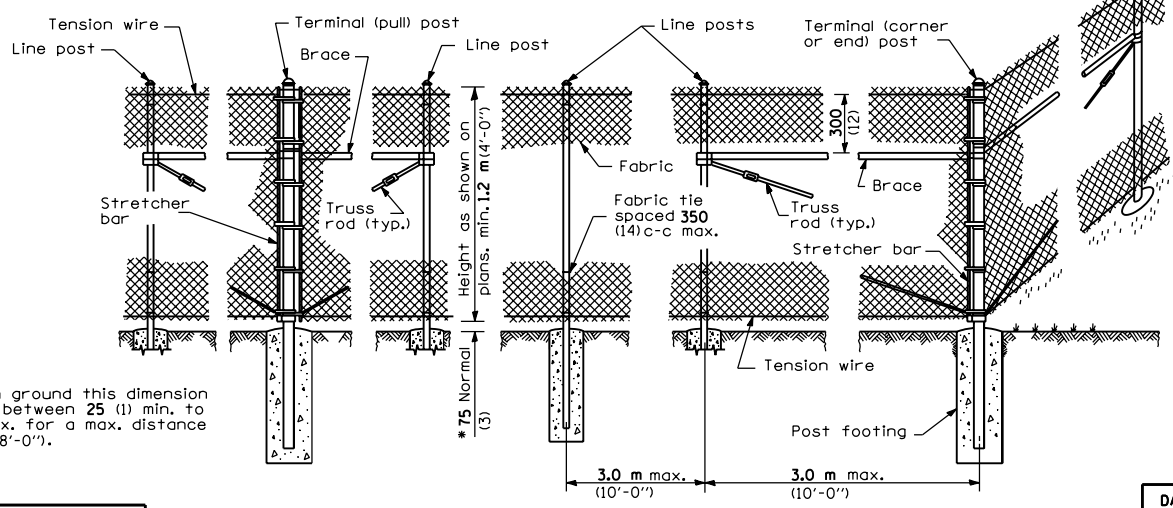

PULL POST ARRANGEMENT

LINE POST ARRANGEMENT

CORNER OR END POST ARRANGEMENT

* On uneven ground this dimension may vary between 25 (1) min. to 125 (5) max. for a max. distance of 2.4 m (8'-0").

Illinois Department of Transportation
 PASSED January 1, 1999
Charles Kolb
 ENGINEER OF POLICY AND PROCEDURES
 APPROVED January 1, 1999
Bill Swinley
 ENGINEER OF DESIGN AND ENVIRONMENT

DATE	REVISIONS
1-1-99	Rev. "pans" to "plans" in LINE POST ARRANGEMENT.
1-1-97	Renum. Standard 2168-12. Rev. top and bottom selvage type.

CHAIN LINK FENCE
 (Sheet 1 of 3)
STANDARD 664001-01

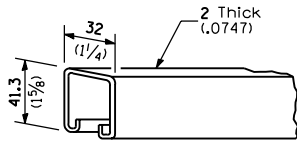

ROLL FORMED SECTION OF BRACE

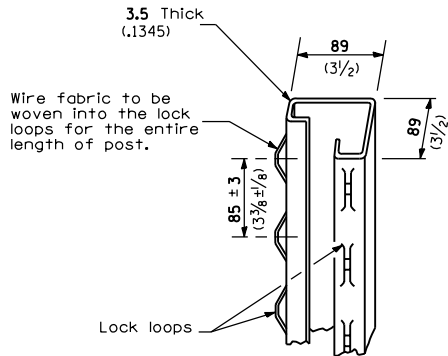

ROLL FORMED SECTION OF TERMINAL & GATE POST

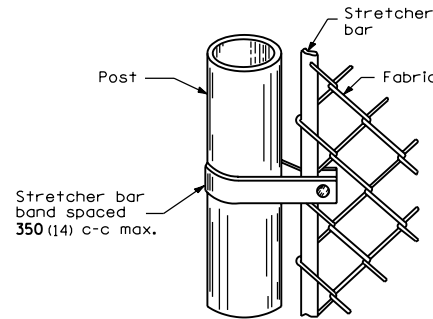

METHOD OF FASTENING STRETCHER BAR TO POST

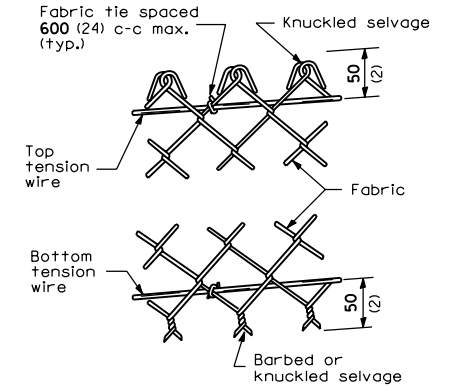

METHOD OF TYING FABRIC TO TENSION WIRES

LINE POST	
Section	kg/m (lbs./ft.)
Pipe Type A 48.3 O.D. (1.90)	4.05 (2.72)
Pipe Type B 48.3 O.D. (1.90)	3.39 (2.28)
Pipe Type C 48.3 O.D. (1.90)	3.36 (2.26)
H 47.6x41.3 (1.875x1.625)	4.05 (2.72)
□	2.38 (1.60)
I	3.42 (2.30)

TERMINAL POST	
Section	kg/m (lbs./ft.)
Pipe Type A 60.3 O.D. (2.375)	5.43 (3.65)
Pipe Type B 60.3 O.D. (2.375)	4.63 (3.11)
Pipe Type C 60.3 O.D. (2.375)	4.60 (3.09)
Roll Formed 89.0x89.0 (3 1/2 x 3 1/2)	See detail
Sq. Tubing 63.5x63.5 (2 1/2 x 2 1/2)	6.43 (4.32)

HORIZONTAL BRACES	
Section	kg/m (lbs./ft.)
Pipe Type A 42.2 O.D. (1.66)	3.38 (2.27)
Pipe Type B 42.2 O.D. (1.66)	2.72 (1.83)
Pipe Type C 42.2 O.D. (1.66)	2.71 (1.82)
H 33.3x38.1 (1.31x1.5)	3.35 (2.25)
Roll Formed 41.3x31.8 (1 5/8 x 1 1/4)	See detail

GRATE FRAMES	
Section	kg/m (lbs./ft.)
Pipe Type A 42.2 O.D. (1.66)	3.38 (2.27)
Pipe Type B 42.2 O.D. (1.66)	2.72 (1.83)
Pipe Type C 42.2 O.D. (1.66)	2.71 (1.82)

GATE POSTS *							
Gate Opening * m (ft.)		Pipe Type A		Sq. Tubing		Pipe Type B	
Single	Double	Size (O.D.)	kg/m (lbs./ft.)	Size	kg/m (lbs./ft.)	Size (O.D.)	kg/m (lbs./ft.)
Up to 1.2 (4)	Up to 2.5 (8)	60.3 (2.375)	5.43 (3.65)	63.5 (2 1/2)	6.43 (4.32)	60.3 (2.375)	4.63 (3.11)
Over 1.2 to 2.5 (4) (8)	Over 2.5 to 5.0 (8) (16)	73.0 (2.875)	8.62 (5.79)	76.2 (3)	8.60 (5.78)	73.0 (2.875)	6.91 (4.64)
Over 2.5 to 3.6 (8) (12)	Over 5.0 to 7.4 (16) (24)	89.0 (3.5)	11.28 (7.58)	76.2 (3)	13.10 (8.80)	89.0 (3.5)	8.49 (5.707)

* The 89.0 x 89.0 (3 1/2 x 3 1/2) roll formed section as detailed may be used as gate posts for single gate up to 1.8 m (6') and double gate up to 3.6 m (12').

All dimensions are in millimeters (inches) unless otherwise shown.

Illinois Department of Transportation

PASSED January 1, 1999
Charles Kelly
 ENGINEER OF POLICY AND PROCEDURES

APPROVED January 1, 1999
Bill Swales
 ENGINEER OF DESIGN AND ENVIRONMENT

ISSUED 1-1-97

CHAIN LINK FENCE

(Sheet 2 of 3)

STANDARD 664001-01

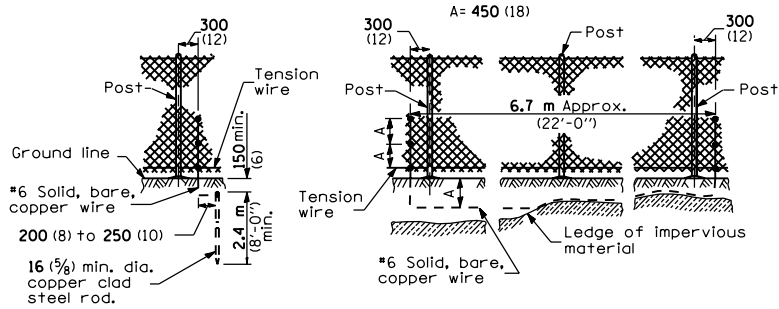

STANDARD GROUND

COUNTERPOISE GROUND (ALTERNATE)

PROTECTIVE ELECTRICAL GROUNDS

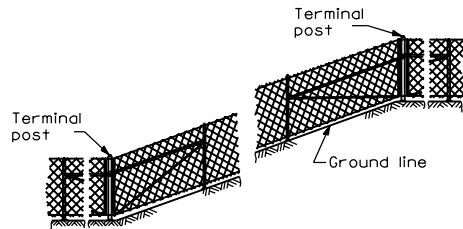

INSTALLATION ON SLOPES

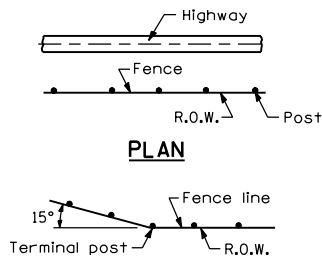

When fence line has a change in direction of 15° or more, a terminal post shall be placed as shown above.

Where angle is less than 15° and existing conditions require a terminal post, they shall be placed as directed by the Engineer.

INSTALLATION AT CORNERS

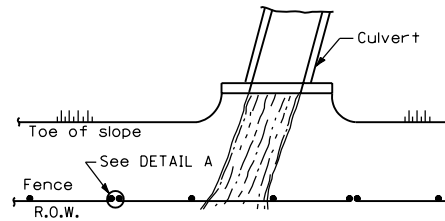

PLAN AT STREAM CROSSING

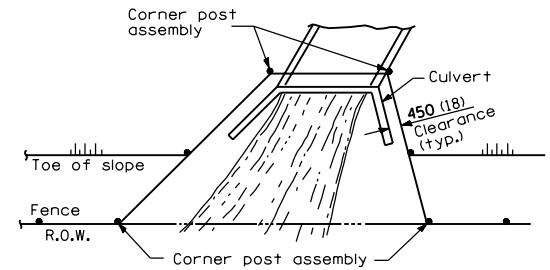

PLAN AT HEADWALL

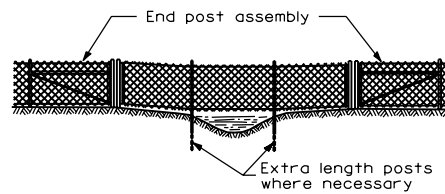

ELEVATION INSTALLATION OVER STREAM

The chain link fabric shall be replaced by barbed wire strands at 300 (12) maximum centers between the double posts shown on DETAIL A when shown on the plans.

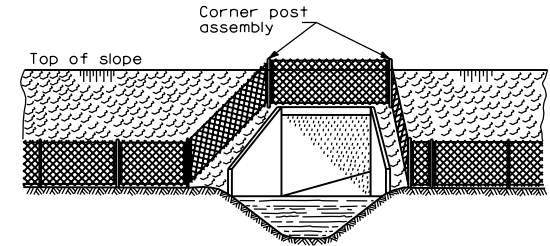

ELEVATION INSTALLATION AROUND HEADWALL

When the width of the culvert makes it necessary to anchor a post to the top of the culvert, a cast iron shoe or other device approved by the Engineer shall be used.

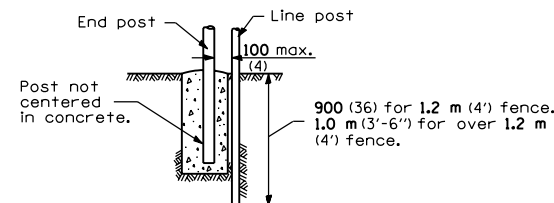

DETAIL A

All dimensions are in millimeters (inches) unless otherwise shown.

Illinois Department of Transportation

PASSED January 1, 1999
Charles Kelliford
ENGINEER OF POLICY AND PROCEDURES

APPROVED January 1, 1999
Bill Swinley
ENGINEER OF DESIGN AND ENVIRONMENT

ISSUED 0-1-1-97

CHAIN LINK FENCE

(Sheet 3 of 3)

STANDARD 664001-01

IDOT DIVISION OF AERONAUTICS POLICY MEMORANDUMS

State of Illinois
Department of Transportation
Division of Aeronautics

POLICY MEMORANDUM

January 1, 2004

Springfield

Number 96-1

TO: CONSULTING ENGINEERS

SUBJECT: ITEM 610, STRUCTURAL PORTLAND CEMENT CONCRETE:
JOB MIX FORMULA APPROVAL & PRODUCTION TESTING.

- I. This policy memorandum addresses the Job Mix Formula (JMF) approval process and production testing requirements when Item 610 is specified for an airport construction contract.
- II. PROCESS
 - a. The contractor may submit a mix design with recent substantiating test data or he may submit a mix design generated by the Illinois Division of Highways with recent substantiating test data for approval consideration. The mix design should be submitted to the Resident Engineer.
 - b. The Resident Engineer should verify that each component of the proposed mix meets the requirements set forth under Item 610 of the *Standard Specifications for Construction of Airports* and/or the contract special provisions.
 - c. The mix design should also indicate the following information:
 1. The name, address, and producer/supplier number for the concrete.
 2. The source, producer/supplier number, gradation, quality, and SSD weight for the proposed coarse and fine aggregates.
 3. The source, producer/supplier number, type, and weight of the proposed flyash and/or cement.
 4. The source, producer/supplier number, dosage rate or dosage of all admixtures.
 - d. After completion of Items b and c above, the mix with substantiating test data shall be forwarded to the Division of Aeronautics for approval. Once the mix has been approved the production testing shall be at the rate in Section III as specified herein.

III. PRODUCTION TESTING

- a. One set of cylinders or beams, depending on the strength specified, shall be cast for acceptance testing for each day the mix is used. In addition, at least one slump and one air test shall be conducted for each day the mix is used. If more than 100 c.y. of the mix is placed in a given day, additional tests at a frequency of 1 per 100 c.y. shall be taken for strength, slump, and air. In **no** case will concrete with a slump greater than 4 inches be allowed for use on the project.
- b. If the total proposed amount of Item 610 Structural Portland Cement Concrete as calculated by the Resident Engineer is less than 50 c.y. for the entire project, the following shall apply:
 - The Resident Engineer shall provide a copy of the calculations of the quantity of Item 610 to the Division of Aeronautics.
 - One set of cylinders or beams, depending the strength specified, shall be cast for acceptance testing.
 - One air content and one slump test shall be taken for acceptance testing.
 - In no case will concrete with a slump greater than 4 inches be allowed for use on the project.
- c. The Resident Engineer shall collect actual batch weight tickets for every batch of Item 610 concrete used for the project. The actual batch weight tickets shall be kept with the project records and shall be available upon request of the Department of Transportation.

Steven J. Long, P.E.
Acting Chief Engineer

Supersedes Policy Memorandum 96-1 dated January 1, 2003

APPENDIX

STANDARD SPECIFICATIONS FOR THE CONSTRUCTION OF WATER MAIN

AQUA ILLINOIS INC.

DIVISION II

SECTION 20

TABLE OF CONTENTS

<u>REFERENCE NO.</u>	<u>DESCRIPTION</u>	<u>PAGE NO.</u>	
PART 1 - GENERAL			
1.1	Description.....	3	
1.2	Work & materials.....	3	
1.3	Reference specifications.....	3	
1.4	Safety.....	4	
1.5	Coordination of work.....	4	
1.6	Payment items.....	5	
1.7	Change orders.....	5	
PART 2 - PRODUCTS.			5
PART 3 - EXECUTION OF THE WORK			
3.1	Site preparation.....	8	
3.2	Soil excavation.....	9	
3.3	Rock excavation.....	9	
3.4	Pipelaying.....	10	
3.5	Backfilling.....	10	
3.6	Trench maintenance.....	11	
3.7	Pavement restoration.....	11	
3.8	Flushing.....	12	
3.9	Disinfecting.....	12	
3.10	Testing.....	13	
3.11	Horizontal & vertical separation-water mains and sewers.....	13	

SECTION 20

STANDARD SPECIFICATIONS FOR THE CONSTRUCTION OF WATER MAIN

AQUA ILLINOIS INC.

PART 1 - GENERAL

1.1 DESCRIPTION

A. Work included:

1. The purpose of these specifications is to provide the main framework for the construction of water main for the Aqua Illinois Inc. (Owner). The content of this document is therefore by necessity of a general nature, which applies, to all projects. A Special Provisions Section shall accompany these Standard Specifications for each project and shall include the work and pay items, which are unique to the particular project. In the event a conflict between the Special Provisions and these Standard Specifications shall occur, the Special Provisions shall rule.

1.2 WORK AND MATERIALS TO BE PROVIDED BY THE CONTRACTOR

- A. All work and materials described in these Specifications shall be provided by the Contractor.
- B. In addition, the Contractor shall purchase and provide all chemicals, necessary to disinfect the water main prior to placing it into service.
- C. The Owner is not exempt from sales tax for the materials used for water main construction. When tie-ins to the existing system are made, the Contractor shall advise the Engineer at least one week in advance of when the connection will be needed. The Contractor shall assert no claims due to delays allegedly caused by the Owner.
- D. The Contractor shall obtain and pay for all temporary office facilities, utilities, and material or equipment storage areas, which the Contractor desires and are not shown on the drawings to be provided by the Owner.

1.3 REFERENCE SPECIFICATIONS

- A. These specifications make reference and incorporate other standard specifications. The referenced specifications

include latest versions of:

1. "AWWA Standards" (AWWA).
 2. "Standard Specifications for Water and Sewer Main Construction in Illinois" (ISPE, CECI, IML, and AGCI).
 3. "Standard Specifications for Road and Bridge Construction" (IDOT).
- B. All bidding Contractors are advised to obtain a copy of each specification for their review during bidding and construction.
- C. A copy of each specification is available at the office of the Engineer for review.
- D. In case of a conflict between these specifications prepared by the Engineer and the reference specifications, the Engineer's specifications shall rule.
- E. When reference is made to a reference specification, that specification shall be followed as if it were an integral part of the Engineer's specifications.

1.4 SAFETY

- A. The Contractor is responsible for the protection of persons from injury and prevention of property damage at the project site.
1. All OSHA regulations regarding proper working practices shall be used.
 2. All IDOT safety requirements on the marking and performance of construction in roadways shall apply whether the construction is along IDOT roadways or not.
 3. The Contractor shall take whatever steps necessary to protect the public from open trenches, material piles, and all other site obstructions.

1.5 COORDINATION OF WORK

- A. The Contractor shall coordinate all subcontractors, affected utilities, and governmental agencies that have an involvement in the construction of the project.
1. Roadways shall remain open to the degree satisfactory with the affected governmental agency.

2. Utility service shall remain in near continuous operation to the satisfaction of the utility. During bidding, the Contractor should determine if nighttime or other off-time work will be necessary to maintain the desired level of service.
3. All subcontractors shall coordinate their work and arrangements directly through the Contractor.

1.6 PAYMENT ITEMS

- A. Payment items shall be as described in the Special Provisions.
- B. Unless specifically identified as a pay item, the cost of all other items are considered incidental and shall be included in the pay items set forth.

1.7 CHANGE ORDERS

- A. Any significant physical deviation from the Specifications and Drawings or any deviation which affects the completion time or cost of the project shall be considered a change and shall be performed only after the proper completion of a Change Order acknowledged by the Engineer, Owner, and Contractor. The Change Order shall address the reason for the change, the effect on completion time, and the effect on project cost. Any deviation from the Specifications and Drawings performed without a properly completed Change Order shall be performed at the Contractor's risk of payment and acceptance by the Owner.

PART 2 - PRODUCTS

2.1 Ductile Iron Pipe

- A. AWWA C151 materials and details
- B. AWWA C150 class 350 thickness except if shown differently on the Drawings
- C. AWWA C104 cement lined interior, bituminous coated exterior
- D. AWWA C111 slip on or mechanical joints, rubber gaskets
- E. Approved Manufacturers:
 1. U.S. Pipe

2. Clow

F. Of the sizes shown on the Drawings

2.2 Polyvinyl Chloride (PVC) Pipe

A. Certa-Lok DR 18 C900/RJ, restrained joint PVC pipe for directional boring.

2.3 Cast and Compact Ductile Iron Fittings

A. AWWA C110 or AWWA C153 for materials and details

B. Bituminous interior lining and exterior coating

C. Slip or mechanical joint

D. Of the sizes shown on the Drawings

2.4 Joint Restraint

A. U.S. Pipe "Field Lok" gasket system for "Tyton Joints."

B. For mechanical joints "Megalug" Series 1100 for ductile iron pipe or Series 2000 PV for PVC pipe.

2.5 Polyethylene Encasement

A. AWWA C105 for the encasement of pipe in polyethylene tubes using plastic tape or twine to secure the wrap in place.

B. 8 MIL thick polyethylene sheets for the wrapping of all other metallic fittings, bolts, hydrants, thrust rods, and valves to be buried beneath ground level. Plastic tape or twine to secure the wrap in place.

2.6 Butterfly Valves

A. AWWA C504 for buried service

B. Class 150

C. Cast iron disc, resilient seat

D. Manual operator

E. Mechanical joint

F. With cast iron valve box and lid

G. Of the size shown on the Drawings

H. Approved manufacturer: Mueller, U.S. Pipe

2.7 Gate Valves

- A. AWWA C509 for buried service
- B. Manual operating nut and resilient seat
- C. Slip-on joint
- D. With cast iron valve box and lid
- E. Of the size shown on the Drawings
- F. Approved manufacturer: Mueller, U.S. Pipe

2.8 Hydrants

- A. AWWA C502 for dry barrel fire hydrants
- B. National standard hose and pumper connections: three-way, 2 1/2 in. X 2 1/2 in. X 4 1/2 in.
- C. 6 In. slip joint inlet connection
- D. 5 1/4 In. valve opening. Open CCW, with 1 1/2 in. pentagon nut
- E. 5 ft. depth of bury.
- F. Break away design. Color - yellow.
- G. Approved manufacturer and model: Mueller Super Centurion 200, U.S. Pipe.

2.9 Casing Pipe

- A. New grade B seamless steel
- B. Welded connections
- C. 3/8 In. thickness minimum
- C. Of the size and length shown on the Drawings

2.10 Casing Spacers and End Seals

- A. 14 Ga. Stainless steel band, 8 in. wide, with PVC liner and low friction runners. Rubber end seals with stainless steel bands. All by Cascade Waterworks Mfg.

Co.

PART 3 - EXECUTION

3.1 Site Preparation

A. Work included:

1. The Special Provisions shall note any special considerations such as separating topsoil or removing trees and shrubs from the project site.
2. The path of the water main shall be cleared of obstructions to the equipment used to construct the main to the extent possible and leveled if necessary to facilitate the installation of the pipe. Caution should be exercised when leveling is performed to assure the fire hydrant settings, pipe cover, etc... is consistent with the restored grades.
3. Sites for material and spoil storage should be planned to not interfere with the construction.
4. When construction is in built-up areas, the Contractor shall make photos or video tape of the proposed trench path for himself and present a copy to the Engineer. Existing defects in the sidewalks, driveways, etc... shall be noted on the photos.
5. All physical features that will be affected by the Construction shall be carefully identified, marked, and reviewed with the Engineer prior to commencing the construction activity. These items include but are not limited to: sidewalks, driveways, trees, and shrubs. Except as noted in the Special Provisions, these items shall be restored to as good or better condition by the Contractor at the conclusion of the project.

3.2 Soil Excavation

- A. Soil excavation shall be performed by backhoe or trencher.
- B. Soil shall be excavated to the level necessary to accommodate any special bedding required and achieve a minimum of 4 ft.6 in. and a maximum of 6 ft. 0 in. of cover over the top surface of the pipe barrel. In trenches with rock excavation, 3 ft. 6 in. of cover over

the top of the pipe shall be achieved.

- C. The variation of trench bottom elevation shall generally conform to the existing ground surface except it shall not change drastically nor more than 3 ft. in 100 ft. of trench length except as shown on the Drawings. Changes in grade which form an upward loop that could trap air shall be avoided.
- D. Soil spoil from the trench excavation shall be deposited no closer than 2 ft. from the edge of the trench and in such a manner that allows traffic to pass. Spoil that will not be returned to the trench because of unsuitability or displacement due to special bedding or backfill shall be immediately hauled from the site to an approved disposal area.
- D. Over-excavated areas shall be brought up to grade level with no more than 6 in. lifts of compacted IDOT CA6 stone.
- E. The trench shall be excavated in accordance with all applicable regulatory and OSHA standards. The maximum trench bottom width measured at the top of the pipe shall not exceed 3 ft. plus the Outside diameter of the pipe.

If these trench widths are exceeded, the Engineer shall evaluate if additional pipe thickness or special bedding and backfilling procedures are necessary. The cost of the additional thickness, bedding, and backfilling shall be paid by the Contractor at no expense to the Owner.

- F. When the trench crosses a previous excavation, IDOT CA6 shall be used as bedding and backfill to the extent necessary to produce a stable trench for the water main and other buried facility.
- G. The excavation shall be maintained in a relatively dry and workable condition by the Contractor who shall employ whatever methods necessary to dewater the trench.

3.3 Rock Excavation

- A. For the purposes of this specification and payment, rock shall be classified as hard, non-soil materials in excess of 0.5 cy. in size which must be removed from the excavation or continuous materials which, in the sole opinion of the Engineer, cannot be excavated from the trench by back hoe buckets or trenchers in good condition, without extraordinary effort.
- B. All other portions of Section 3.2 Soil Excavation apply.

- C. Rock materials taken from the trench which weigh in excess of 5 lb. shall be removed from the site and disposed by the Contractor. Rock materials less than 5 lb. each may only be used in backfill material in the layer 2 ft. above the top of the pipe and 1 ft. below the final ground surface. In this case, the rock materials must be well mixed with soils and can make up no more than 25% of the backfill mixture.
- D. Rock materials shall be removed a minimum of 8 in. on the sides of the pipe and 4 in. below the pipe in accordance with the detail on the plans. The trench shall then be brought up to grade using IDOT CA6 and shall be well compacted.

3.4 Pipelaying

- A. Pipe shall be laid in strict accordance with AWWA C600.
- B. Pipe shall be carefully handled to protect the inner and outer coatings. The Contractor shall use slings or special pipe clamps to handle the pipe. Rolling the pipe off trucks or into the trench is forbidden.
- C. The Owner shall provide pipe plugs for use by the Contractor to protect the pipe from intrusion by trench water or other foreign objects. The pipe plugs shall be immediately installed whenever pipelaying is not in progress.
- D. Cast in place concrete thrust blocks shall be used at every fitting and hydrant as shown on the Drawings. Alternatively, approved joint restraint system may be used for fitting restraint instead of the cast in place thrust blocks. If this alternative is used, the joint restraint will be installed at each fitting, and at other pipe joints adjacent to the fitting, as directed by the Engineer.
- E. All ductile iron pipe shall be encased in polyethylene tubes in accordance with AWWA C105. All buried fittings, valves, etc., shall be encased similarly in 8 mil polyethylene sheets.

3.5 Backfilling

- A. Backfilling shall be as specified in AWWA C600.
- B. For unpaved areas, soft soil crumbles taken from the side of the trench, clean excavated soils free from large

pieces, or specified select backfill shall be used to bring the backfill up to the center of the pipe. This material shall be tamped under the haunch of the pipe. The same materials shall then be carefully placed to a point at least 6 in. above the top of the pipe. At this point, machine backfilling can commence. The trench shall be finished by mounding the excavated soils over the trench.

- C. For paved areas, all excavated materials shall be hauled from the site and disposed by the Contractor. The entire trench shall be filled with granular material, as specified in the Special Provisions, and compacted.

3.6 Trench Maintenance

- A. In unpaved areas, the trench mound shall be maintained by the Contractor for a period of one year following the completion of the backfilling.
- B. The mound shall be shaped to allow traffic to pass if applicable and be of a round shape if pedestrian traffic is anticipated. The Contractor shall immediately add soil or reshape the mound if more than a 6 in. settlement below the existing ground surface occurs.
- C. If the Special Provisions call for seeding or sodding of the site area, it shall be done in accordance with "Standard Specifications for Water and Sewer Main Construction in Illinois" Section 21-2.05 for Class 1 Seeding mixtures.
- D. If the Special Provisions call for tree or shrub replacement, trees or shrubs shall be replaced by the Contractor with units at least as good as those removed.
- E. The Contractor shall be responsible for the complete care of all grass, trees, shrubs, and other vegetation disturbed or destroyed during the construction for a period of at least one year after replanting.

3.7 Pavement Restoration

- A. All backfill to be under pavement including sidewalks, curbs, gutters, and driveways, shall be thoroughly compacted prior to the placement of the permanent surface. Compaction methods shall be approved by the Engineer and shall be thorough and effective.
- B. The pavement shall be restored to original or better condition. Details for the restoration are shown on the Drawings.

- C. Materials used in the restoration shall be approved in the latest edition of the "Standard Specifications for Road and Bridge Construction," by the Illinois Department of Transportation.
- D. Roadways may be temporarily repaired to the satisfaction of the Engineer and governmental agency controlling the roadway. Such temporary surfacing shall include IDOT CA6 or CA10 and cold patch asphalt. The Contractor shall be responsible for the performance of the temporary repair and shall promptly maintain the repair if necessary. All temporary repairs should be replaced with permanent repairs as soon as practical to do so.

3.8 Flushing

- A. Following completion of the water main, the pipe shall be flushed using water from the existing potable water system by the Owner.
- B. The flushing rate shall be at a minimum velocity of 2 1/2 fps.
- C. The water from the flushing operation shall be discharged from a hydrant or hydrants located at the end of the pipe opposite the water addition point to assure all parts of the main are flushed. In addition, hydrants located near or at high elevations of the main shall be opened when initially filling the pipe to expel trapped air.
- D. All water from the flushing operation shall be directed to storm, sanitary sewers, or waterways to minimize public inconvenience.

3.9 Disinfection

- A. The main shall be disinfected in accordance with "Standard Specifications for Water and Sewer Main Construction in Illinois," Section 41-2.14 and AWWA C651.
- B. Following flushing, the mains shall be disinfected using the gas chlorination method.
- C. Following the required detention time, the system shall be flushed until a normal chlorine residual (approximately 1 mg/l) is achieved. Two samples shall then be taken at 24 hr. intervals. Should either sample fail coliform testing, a check sample shall be taken. If the check sample fails, the disinfection procedure shall be repeated again, and so on until the main passes two consecutive coliform tests.

- D. If the check sample fails the main shall be rechlorinated by the Contractor until the main passes the testing procedure.

3.10 Pressure and Leakage Testing

- A. Following satisfactory coliform testing, the main shall be subjected to the pressure and leakage tests described in "Standard Specifications for Water and Sewer Main Construction in Illinois" Section 41-2.13 and AWWA C600 by the Owner.
- B. All work and repairs necessary to obtain satisfactory tests shall be borne by the Contractor.

3.11 Horizontal & Vertical Separation-Water Mains and Sewers.

A. Horizontal

1. Water mains shall be located at least 10 feet horizontally from any existing or proposed drain, storm sewer, sanitary sewer, combined sewer or sewer service connection.
2. Water mains may be located closer than 10 feet to a sewer line when
 - a. Local conditions prevent a lateral separation of 10 feet; and
 - b. The water main invert is at least 18 inches above the crown of the sewer; and
 - c. The water main is either in a separate trench or in the same trench on an undisturbed earth shelf located to one side of the sewer.
3. When it is impossible to meet 1 and 2 above, both the water main and drain or sewer shall be constructed of slip-on or mechanical joint cast or ductile iron pipe, pre-stressed concrete pipe, or PVC pipe equivalent to water main standards of construction. The drain or sewer shall be pressure tested to the maximum expected surcharge head before backfilling.

B. Vertical

1. A water main shall be separated from a sewer so that its invert is a minimum of 18 inches above the crown of the drain or sewer whenever water mains cross storm sewers, sanitary sewers or sewer

service connections. The vertical separation shall be maintained for that portion of the water main located within 10 feet horizontally of any sewer or drain crossed. A length of water main pipe shall be centered over the sewer to be crossed with joints equidistant from the sewer or drain.

2. Both the water main and sewer shall be constructed of slip-on or mechanical joint cast or ductile iron pipe, pre-stressed concrete pipe, or PVC pipe equivalent to water main standards of construction when:
 - a. It is impossible to obtain the proper vertical separation as described in 1 above; or
 - b. The water main passes under a sewer or drain.
3. A vertical separation of 18 inches between the invert of the sewer or drain and the crown of the water main shall be maintained where a water main crosses under a sewer. Support the sewer or drain lines to prevent settling and breaking the water main, as shown on the Drawings or as approved by the Engineer.
4. Construction shall extend on each side of the crossing until the perpendicular distance from the water main to the sewer or drain line is at least 10 feet.