

F.A.U. RTE.	SECTION	COUNTY	TOTAL SHEETS	SHEET NO.
3549	19-00121-00-R5	DUPAGE	35	1
ILLINOIS CONTRACT NO. 61G23				

FOR INDEX OF SHEETS AND
HIGHWAY STANDARDS
SEE SHEET 2

03-06-2020 LETTING ITEM 009

STATE OF ILLINOIS DEPARTMENT OF TRANSPORTATION PLANS FOR PROPOSED FEDERAL AID HIGHWAY

FAU ROUTE 3549 (MANCHESTER RD)
COUNTY FARM RD TO GABLES BLVD
RESURFACING, CURB AND SIDEWALK
SECTION NO.: 19-00121-00-RS
PROJECT NO.: YDJE(743)
CITY OF WHEATON
DUPAGE COUNTY
JOB NO.: C-91-391-19



LOCATION OF SECTION INDICATED THIS: -

STATE OF ILLINOIS
DEPARTMENT OF TRANSPORTATION

APPROVED 11-21-19 *Paul Redner*
CITY OF WHEATON, DIRECTOR OF ENGINEERING

PASSED 12-9-19 *G.A. Friel*
DISTRICT 1 ENGINEER OF LOCAL ROADS & STREETS

RELEASING FOR
LIMITED REVIEW 12-9-19 *Anthony J. Dwyer*
REGIONAL ENGINEER

PRINTED BY THE AUTHORITY
OF THE STATE OF ILLINOIS

PROFESSIONAL ENGINEER'S CERTIFICATION

I HEREBY CERTIFY THAT THIS SUBMISSION WAS PREPARED
UNDER MY PERSONAL DIRECTION. THIS TECHNICAL
SUBMISSION IS INTENDED TO BE USED AS AN INTEGRAL
PART OF AND IN CONJUNCTION WITH THE PROJECT
SPECIFICATIONS AND CONTRACT DOCUMENTS.

DATED THIS 25TH DAY OF NOVEMBER, 2019

James M. Yuratovac
JAMES M. YURATOVAC
ILLINOIS REG. PROF. ENGINEER NO 062-060059 EXPIRATION DATE 11-30-2021



PROGRAM AND OFFICE ENGINEER: CARMEN E. RAMOS, P.E., SCHAUMBURG, IL 847-705-4021

MANCHESTER RD

DESIGN DESIGNATION: LOCAL
SPEED LIMIT = 30 MPH
TRAFFIC = 4800 ADT (2016)
5400 ADT (2040)

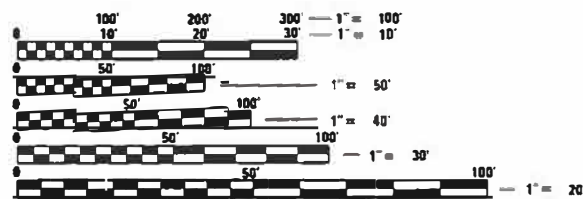

FULL SIZE PLANS HAVE BEEN PREPARED USING STANDARD
ENGINEERING SCALES. REDUCED SIZED PLANS WILL NOT
CONFORM TO STANDARD SCALES. IN MAKING MEASUREMENTS
ON REDUCED PLANS, THE ABOVE SCALES MAY BE USED.

J.U.L.I.E.
JOINT UTILITY LOCATION INFORMATION FOR EXCAVATION
1-800-892-0123
OR 811



PROJECT MANAGER: JIM YURATOVAC

CONTRACT NO. 61G23

R 10 E 3RD P.M.

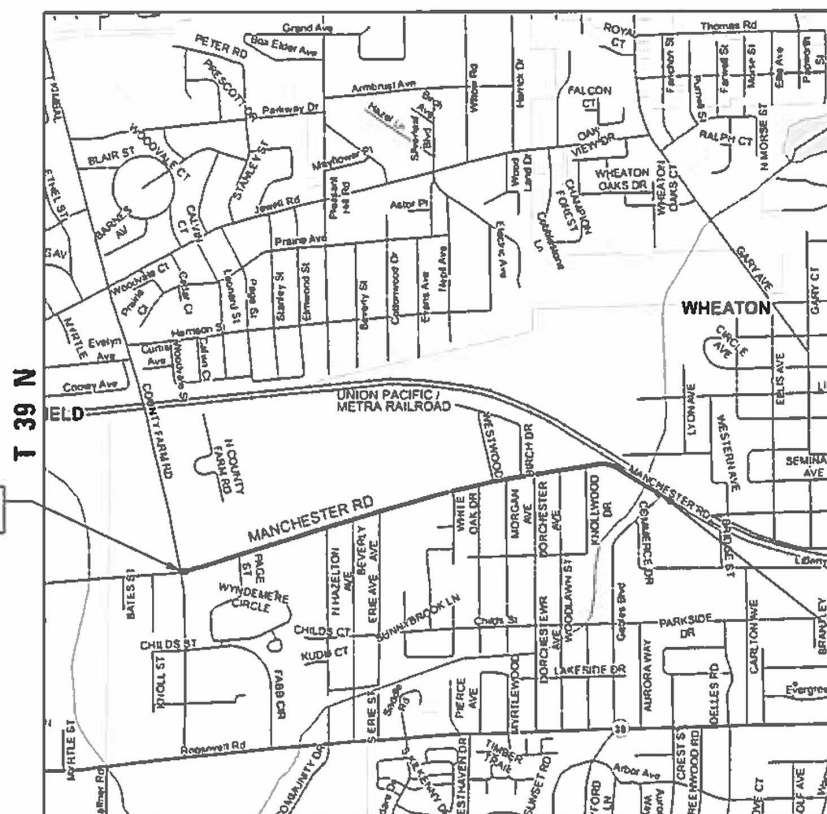

PROJECT BEGINS
STA. 10+30

PROJECT ENDS
STA. 73+80

MILTON TOWNSHIP
LOCATION MAP

N.T.S.

GROSS LENGTH = 6350 FT. = 1.20 MILES

NET LENGTH = 6350 FT. = 1.20 MILES



INDEX OF SHEETS

1	TITLE SHEET
2	GENERAL NOTES
3-4	SUMMARY OF QUANTITIES
5-6	TYPICAL SECTIONS
7-12	ROADWAY PLANS
13-18	PAVEMENT MARKING PLANS
19-23	SIDEWALK/ADA PLANS
24	DETECTOR LOOP PLANS
25-26	WHEATON DETAILS
27-35	DISTRICT ONE DETAILS

DISTRICT 1 DETAILS

BD-03	OUTLET FOR CONCRETE CURB AND GUTTER
BD-22	PAVEMENT PATCHING FOR HMA SURFACED PAVEMENT
BD-24	CURB OR CURB AND GUTTER REMOVAL AND REPLACEMENT
BD-32	BUTT JOINT AND HMA TAPER DETAILS
TC-10	TRAFFIC CONTROL AND PROTECTION FOR SIDE ROADS, INTERSECTIONS AND DRIVEWAYS
TC-13	TYPICAL PAVEMENT MARKINGS
TC-16	PAVEMENT MARKING LETTERS AND SYMBOLS FOR TRAFFIC STAGING

HIGHWAY STANDARDS

000001-07	STANDARD SYMBOLS, ABBREVIATIONS, AND PATTERNS
424001-11	PERPENDICULAR CURB RAMPS FOR SIDEWALKS
424006-04	DIAGONAL CURB RAMPS FOR SIDEWALKS
424011-04	CORNER PARALLEL CURB RAMPS FOR SIDEWALKS
424016-05	MID-BLOCK CURB RAMPS FOR SIDEWALKS
424021-05	DEPRESSED CORNER FOR SIDEWALKS
424026-03	ENTRANCE / ALLEY PEDESTRIAN CROSSINGS
442201-03	CLASS C AND D PATCHES
606001-07	CONCRETE CURB TYPE B AND COMBINATION CONCRETE CURB AND GUTTER
701006-05	OFF-ROAD OPERATIONS, 2L, 2W, 15' TO 24" FROM PAVEMENT EDGE
701301-04	LANE CLOSURE, 2L, 2W, SHORT TIME OPERATIONS
701311-03	LANE CLOSURE, 2L, 2W, MOVING OPERATIONS- DAY ONLY
701501-06	URBAN LANE CLOSURE, 2L, 2W, UNDIVIDED
701701-10	URBAN LANE CLOSURE, MULTILANE INTERSECTION
701801-06	SIDEWALK, CORNER OR CROSSWALK CLOSURE
701901-08	TRAFFIC CONTROL DEVICES
780001-05	TYPICAL PAVEMENT MARKINGS

GENERAL NOTES:

- 1 ALL REFERENCES TO "STANDARD SPECIFICATIONS" IN THESE GENERAL NOTES SHALL BE INTERPRETED TO MEAN "STANDARD SPECIFICATIONS FOR ROAD AND BRIDGE CONSTRUCTION" ADOPTED BY THE ILLINOIS DEPARTMENT OF TRANSPORTATION, APRIL 1, 2016 AND SUPPLEMENTAL SPECIFICATIONS AND RECURRING SPECIAL PROVISIONS
- 2 THE CONTRACTOR SHALL PROTECT AND CAREFULLY PRESERVE ALL SECTION OR SUBSECTION MONUMENTS, PROPERTY CORNERS, AND REFERENCE MARKERS UNTIL THE OWNER, THEIR AGENT, OR AN AUTHORIZED SURVEYOR HAS WITNESSED OR OTHERWISE REFERENCED THEIR LOCATIONS.
- 3 THE CONTRACTOR SHALL COORDINATE PAVING OPERATIONS FOR BOTH HMA LEVEL BINDER AND SURFACE COURSES SO THAT THE LONGITUDINAL JOINTS ARE CLOSED AND COMPACTED AT THE END OF EACH DAY. PAVING OPERATIONS SHALL BE SCHEDULED SO THAT ADJACENT LANES ARE PAVED IN THE SAME DIRECTION AS THE INITIAL LANE MINIMIZING THE TIME THE EDGE OF A PAVEMENT MAT IS ALLOWED TO COOL.
- 4 THE CONTRACTOR SHALL USE 2 CHANGEABLE MESSAGE SIGNS AT LOCATIONS TO BE DETERMINED BY THE ENGINEER FOR A PERIOD FROM ONE WEEK PRIOR TO THE START OF CONSTRUCTION TO THE CONCLUSION OF THE
- 5 THE CONTRACTOR SHALL ENSURE ALL WATER SYSTEM VALVES, VALVE VAULTS, AND SANITARY SEWER MANHOLES REMAIN READILY ACCESSIBLE FOR EMERGENCY OPERATIONS. THE LOCATIONS OF ALL WATER AND SANITARY FACILITIES SHALL BE MARKED AND READILY VISIBLE AT ALL TIMES.
- 6 THE INDISCRIMINATE USE OF FIRE HYDRANTS, EXISTING STREAMS, CREEKS, WETLANDS, OR PONDS IS STRICTLY PROHIBITED. THE CONTRACTOR SHALL PROVIDE A WATER TRUCK AND DRIVER AS REQUIRED TO OBTAIN AND TRANSPORT THIS WATER. THE CONTRACTOR SHALL BE RESPONSIBLE FOR OBTAINING WATER FROM AN APPROVED SOURCE. IF THIS WATER IS FROM A JURISDICTION FOR THE SOURCE OF THE WATER MUST BE RECEIVED BY THE CONTRACTOR PRIOR TO THE USE OF WATER.
- 7 IT SHALL BE THE CONTRACTOR'S RESPONSIBILITY TO SELECT DUMPING SITES. HE/SHE SHALL PROVIDE A LIST OF THESE SITES TO THE ENGINEER FOR HIS/HER EXAMINATION AND GENERAL INFORMATION.
- 8 ALL EXCESS MATERIAL (BROKEN CONCRETE, ASPHALT, CULVERT PIPE, WASTE ROADWAY EXCAVATION, AND SURPLUS MATERIALS FROM UTILITY TRENCHES) SHALL BE WASTED OUTSIDE THE LIMITS OF THE RIGHT-OF-WAY.
- 9 ALL PROPERTY AND SURFACE STRUCTURES WITHIN THE RIGHT-OF-WAY SHALL BE PROTECTED DURING CONSTRUCTION OPERATIONS UNLESS THE ENGINEER DIRECTS REMOVAL FOR PURPOSES RELATED TO CONSTRUCTION UNDER THIS CONTRACT. ANY FENCES, POLES, FLAGSTONE, DECORATIVE STONE, SPECIAL LANDSCAPING, OR OTHER MAN MADE SURFACE IMPROVEMENT WHICH IS REMOVED OR DISTURBED BY THE CONTRACTOR SHALL BE RESTORED BY HIM TO ITS ORIGINAL CONDITION AFTER THE CONSTRUCTION ACTIVITIES
- 10 ALL FRAMES, GRATES, LIDS, FIRE HYDRANTS, AND VALVE BOXES WHICH ARE REMOVED AND ARE TO BE ABANDONED SHALL REMAIN THE PROPERTY OF THE CITY OF WHEATON. UPON REMOVAL FROM THEIR WORKING LOCATIONS, THEY ARE TO BE STOCKPILED AT AN ON-SITE LOCATION DETERMINED BY THE ENGINEER WHERE THEY WILL BE PICKED UP BY CITY PERSONNEL AT THE CONCLUSION OF WORK ON THAT STREET.
- 11 WHEN EXISTING DRAINAGE FACILITIES ARE DISTURBED, THE CONTRACTOR SHALL PROVIDE AND MAINTAIN TEMPORARY OUTLETS AND CONNECTIONS FOR ALL PRIVATE AND PUBLIC DRAINS, SEWERS, AND CATCH BASINS. THE CONTRACTOR SHALL PROVIDE FACILITIES TO ACCEPT ALL STORM WATER THAT WILL BE DELIVERED BY THESE DRAINS AND BASINS AND SHALL DISCHARGE THE SAME. IF NECESSARY, THE CONTRACTOR SHALL PROVIDE AND MAINTAIN AN EFFICIENT PUMPING PLANT AND TEMPORARY OUTLET AND BE PREPARED AT ALL TIMES TO DISPOSE OF WATER WHICH IS RECEIVED FROM ALL TEMPORARY CONNECTIONS. THESE TEMPORARY FACILITIES SHALL BE MAINTAINED UNTIL ALL PERMANENT CONNECTIONS ARE COMPLETED.
- 12 EROSION AND SEDIMENT CONTROL MEASURES SHALL BE FOLLOWED WHEN EXISTING CURB AND GUTTER IS REMOVED AND EXISTING DRAINAGE STRUCTURES ARE TO REMAIN ACTIVE. THIS WORK SHALL BE PERFORMED IN ACCORDANCE WITH THE DETAIL PROVIDED IN THE CONTRACT DOCUMENTS.
- 13 THE THICKNESS OF THE HMA SHOWN ON THE PLANS IS NOMINAL. DEVIATIONS MAY OCCUR IN THE FIELD DUE TO IRREGULARITIES IN THE EXISTING SURFACE OR BASE UPON WHICH THE HMA IS BEING PLACED.
- 14 THE LOCATIONS AND ELEVATIONS OF THE VARIOUS UNDERGROUND UTILITIES SHOWN ON THE PLANS ARE NOT TO BE TAKEN AS EXACT. THE CONTRACTOR SHALL EXERCISE CARE WHEN CONDUCTING CONSTRUCTION OPERATIONS NEAR UTILITIES TO PREVENT DAMAGE. THE FAILURE OF A UTILITY COMPANY TO ACCURATELY LOCATE THEIR UTILITY DOES NOT FREE THE CONTRACTOR FROM RESPONSIBILITY. THE MAJOR CONCERN OF THE
- 15 THE CONTRACTOR SHALL COOPERATE WITH THE CITY IN ANY UNDERGROUND UTILITY CONSTRUCTION WHICH THE CITY MAY WANT TO PERFORM DURING THE CONTRACTOR'S OPERATIONS.
- 16 THE CONTRACTOR SHALL HAVE LINE AND/OR FORMS SET A MINIMUM OF FOUR WORKING HOURS PRIOR TO THE SCHEDULED ARRIVAL OF CONCRETE ON SITE FOR THE PLACEMENT OF CURB AND GUTTER, DRIVEWAYS, AND SIDEWALK TO ALLOW THE ENGINEER TIME TO CHECK LINE AND GRADE.
- 17 ALL RADII FOR PROPOSED COMBINATION CONCRETE CURB AND GUTTER SHALL BE PLACED AT THE EXISTING DIMENSION UNLESS OTHERWISE INDICATED ON THE PROJECT PLANS OR AS DIRECTED BY THE ENGINEER. ELEVATIONS SHOWN AT POINT ON THE CURB INDICATED FLOW LINE ELEVATIONS UNLESS NOTED OTHERWISE.

- 18 WHEN WATER SERVICE BOXES FALL WITHIN THE LIMITS OF CONCRETE FLATWORK, THE CONTRACTOR SHALL PROVIDE EITHER A SECTION OF 4" POLY VINYL CHLORIDE (PVC) PIPE OR 4" HIGH DENSITY POLYETHYLENE (HDPE) PIPE TO SLEEVE THE BOX. THE SLEEVE SHALL EITHER BE REMOVED OR TRIMMED TO MATCH THE FINISHED CONCRETE GRADE LEVEL. THE FINAL RESULT SHALL BE A SMOOTH FINISHED "BOX-OUT" AROUND THE SERVICE BOX WHICH SHALL FACILITATE EASY REMOVAL OF THE CAP AT MEET THE FINISHED GRADE. ALL WATER SERVICE BOXES WITHIN PAVEMENT RESURFACING SHALL BE ADJUSTED TO MEET THE FINISHED GRADE LEVEL.
- 19 WHEN A SEWER STRUCTURE FALLS WITHIN THE LIMITS OF A CONCRETE DRIVEWAY, THE CONTRACTOR SHALL PLACE EXPANSION MATERIAL IN A BOX APPROXIMATELY EIGHTEEN (18") INCHES FROM THE CENTER OF THE LID FORMING A SQUARE "BOX-OUT" AROUND THE FRAME. THE RESULT SHALL BE A CONDITION THAT WILL ALLOW FOR THE REMOVAL OF THE SQUARE OF CONCRETE FROM THE DRIVEWAY FOR THE PURPOSE OF REPLACING THE FRAME WITHOUT DAMAGING THE REMAINDER OF THE DRIVEWAY PAVEMENT.
- 20 ALL CONSTRUCTION PERSONNEL SHALL BE REQUIRED TO WEAR AN ANSI/ISEA 107-2015 COMPLIANT SAFETY VEST AT ALL TIMES WHILE ON THE CONSTRUCTION SITE.
- 21 WHEN MILLED PAVEMENT IS OPEN TO TRAFFIC THE MAXIMUM GRADE DIFFERENTIAL BETWEEN PASSES OF THE MILLING MACHINE SHALL NOT EXCEED 1-1/2 INCHES WHERE THE SPEED LIMIT IS 45 MPH OR LESS AND 1 INCH WHERE THE SPEED LIMIT IS GREATER THAN 45 MPH. WITH WRITTEN APPROVAL FROM THE ENGINEER, A MAXIMUM GRADE DIFFERENTIAL OF 3 INCHES MAY BE ALLOWED IF THE EDGE OF THE MILLING IS SLOPED A MINIMUM 1:3
- 22 BEFORE BEGINNING ANY WORK, THE CONTRACTOR SHALL RETAIN AND RECORD THE LOCATIONS OF ALL EXISTING PAVEMENT MARKING LINES (AND RAISED REFLECTIVE PAVEMENT MARKERS) IN ORDER THAT THESE LOCATIONS CAN BE REESTABLISHED FOR STRIPING. EXACT LOCATIONS OF ALL PAVEMENT MARKINGS SHALL BE AS DIRECTED
- 23 IT SHALL BE THE CONTRACTOR'S RESPONSIBILITY TO VERIFY ALL DIMENSIONS AND CONDITIONS EXISTING IN THE FIELD PRIOR TO CONSTRUCTION AND ORDERING OF MATERIALS.
- 24 THE CONTRACTOR SHALL PROVIDE SAFE AND ORDERLY PASSAGE FOR TRAFFIC AND PEDESTRIANS WHERE CONSTRUCTION OPERATIONS IMPACT PUBLIC THOROUGHFARES AND ADJACENT PROPERTY. THE CONTRACTOR SHALL PROVIDE ACCESS TO ABUTTING PROPERTY AT ALL TIMES DURING THE CONSTRUCTION OF THIS PROJECT.
- 25 ALL SIDEWALK CURB RAMPS SHALL BE COMPLIANT WITH ALL APPLICABLE ADA STANDARDS AND INCLUDED DETAILS. INDIVIDUAL DESIGN DETAILS HAVE BEEN PROVIDED FOR ALL LOCATIONS WITH AN EXISTING SLOPE
- 26 A NOMINAL QUANTITY HAS BEEN INCLUDED FOR THE FOLLOWING PAY ITEMS:
- EARTH EXCAVATION
- REMOVAL AND DISPOSAL OF UNSUITABLE MATERIAL
- AGGREGATE SUBGRADE IMPROVEMENT
- CLASS D PATCHES
- 27 ALL UTILITY STRUCTURES SHALL REMAIN ACCESSIBLE DURING CONSTRUCTION. WHEN UTILITY STRUCTURES ARE TO BE ADJUSTED UNDER TRAFFIC, TEMPORARY RAMPS SHALL BE CONSTRUCTED AND MAINTAINED AT BOTH UPSTREAM AND DOWNSTREAM ENDS OF THE UTILITY CASTING IN ACCORDANCE WITH ARTICLE 406.08.

GENERAL NOTES - SEWERS:

- 28 ALL FRAMES WITH CLOSED LIDS BEING FURNISHED FOR THIS PROJECT AS CONSTRUCTION, ADJUSTMENT, OR RECONSTRUCTION OF ANY MANHOLE, CATCH BASIN, INLET, OR WATER VALVE VAULT SHALL HAVE CAST INTO THE LID ONE OR MORE OF THE FOLLOWING WORDS:
- "STORM" - FOR STORM SEWER MANHOLE LIDS
- "SANITARY" - FOR SANITARY MANHOLE LIDS
- "WATER" - FOR WATER SYSTEM STRUCTURE LIDS
- "FISH" SYMBOL DIRECTLY ON THE CURB BACK - FOR CURB INLET FRAMES
- 29 IF AT ANY TIME DURING THE CONSTRUCTION OF THIS PROJECT LOOSE MATERIAL IS DEPOSITED INTO THE FLOW LINE OF A SEWER STRUCTURE IN SUCH A WAY AS TO RESTRICT OR OBSTRUCT THE NATURAL FLOW OF WATER IN THE STRUCTURE, THE MATERIAL SHALL BE REMOVED BEFORE THE CLOSE OF THE WORKING DAY DURING WHICH IT WAS DEPOSITED. AT THE CONCLUSION OF CONSTRUCTION ACTIVITIES, AND BEFORE THE ENGINEER ACCEPTS THE PROJECT, ALL SEWERS AND SEWER STRUCTURES THAT FALL WITHIN THE LIMITS OF THE PROJECT SHALL BE FREE OF CONSTRUCTION DEBRIS AND LOOSE MATERIAL.

GENERAL NOTES - UTILITIES:

- 30 PRIOR TO ADJUSTMENT OF ANY NICOR GAS VALVE BOXES THAT REQUIRE ADJUSTMENT, THE CONTRACTOR SHALL CONTACT SUSANNA KNAUTZ, SCHEDULER AT 630-918-0897 A MINIMUM OF TWO WEEKS PRIOR TO FIELD WORK.



thomas engineering group, llc 762 shoreline drive suite 200 aurora, illinois 60504 phone: 855-533-1700	USER NAME = jamesy	DESIGNED -	REVISED
		DRAWN -	REVISED -
	PLOT SCALE = 2.0000' / in.	CHECKED -	REVISED -
	PLOT DATE = 12/27/2019	DATE -	REVISED -

STATE OF ILLINOIS DEPARTMENT OF TRANSPORTATION

GENERAL NOTES

SCALE: SHEET OF SHEETS STA. TO STA.

F.A.U. RTE.	SECTION	COUNTY	TOTAL SHEETS	SHEET NO.
3549	19-00121-00-R5	DuPAGE	35	2
CONTRACT:			61G23	
ILLINOIS FED. AID PROJECT				

SUMMARY OF QUANTITIES

CODE NO.	ITEM	UNIT	TOTAL QTY.
			CONSTR. CODE 0005 STU 70/30
20101200	TREE ROOT PRUNING	EACH	8
20200100	EARTH EXCAVATION	CU YD	20
20201200	REMOVAL AND DISPOSAL OF UNSUITABLE MATERIAL	CU YD	20
21101615	TOPSOIL FURNISH AND PLACE, 4"	SQ YD	305
25200110	SODDING, SALT TOLERANT	SQ YD	305
25200200	SUPPLEMENTAL WATERING	UNIT	2
28000510	INLET FILTERS	EACH	68
30300001	AGGREGATE SUBGRADE IMPROVEMENT	CU YD	20
40600290	BITUMINOUS MATERIALS (TACK COAT)	POUND	15414
40600400	MIXTURE FOR CRACKS, JOINTS, AND FLANGWAYS	TON	11
40600982	HOT-MIX ASPHALT SURFACE REMOVAL - BUTT JOINT	SQ YD	368
40603200	POLYMERIZED HOT-MIX ASPHALT BINDER COURSE, IL-4.75, N50	TON	1279
40604060	HOT-MIX ASPHALT SURFACE COURSE, IL-9.5, MIX "D", N50	TON	2558
42400200	PORTLAND CEMENT CONCRETE SIDEWALK 5 INCH	SQ FT	5288
42400800	DETECTABLE WARNINGS	SQ FT	352
44000161	HOT-MIX ASPHALT SURFACE REMOVAL, 3"	SQ YD	22835
44000500	COMBINATION CURB AND GUTTER REMOVAL	FOOT	1353
44000600	SIDEWALK REMOVAL	SQ FT	5705

CODE NO.	ITEM	UNIT	TOTAL QTY.
			CONSTR. CODE 0005 STU 70/30
44201725	CLASS D PATCHES, TYPE I, 7 INCH	SQ YD	114
44201729	CLASS D PATCHES, TYPE II, 7 INCH	SQ YD	228
44201733	CLASS D PATCHES, TYPE III, 7 INCH	SQ YD	343
44201735	CLASS D PATCHES, TYPE IV, 7 INCH	SQ YD	457
60250400	CATCH BASINS TO BE ADJUSTED WITH NEW TYPE 1 FRAME, OPEN LID	EACH	2
60255500	MANHOLES TO BE ADJUSTED	EACH	9
60255700	MANHOLES TO BE ADJUSTED WITH NEW TYPE 1 FRAME, OPEN LID	EACH	4
60255800	MANHOLES TO BE ADJUSTED WITH NEW TYPE 1 FRAME, CLOSED LID	EACH	15
60261325	INLETS TO BE ADJUSTED WITH NEW TYPE 11 GRATE	EACH	3
60266600	VALVE BOXES TO BE ADJUSTED	EACH	20
60603800	COMBINATION CONCRETE CURB AND GUTTER, TYPE B-6.12	FOOT	1353
67100100	MOBILIZATION	L SUM	1
70102620	TRAFFIC CONTROL AND PROTECTION, STANDARD 701501	L SUM	1
70102635	TRAFFIC CONTROL AND PROTECTION, STANDARD 701701	L SUM	1
70102640	TRAFFIC CONTROL AND PROTECTION, STANDARD 701801	L SUM	1
70107025	CHANGEABLE MESSAGE SIGN	CAL DA	120
70300100	SHORT TERM PAVEMENT MARKING	FOOT	1173
70300150	SHORT TERM PAVEMENT MARKING REMOVAL	SQ FT	391

△ SPECIAL PROVISION
* SPECIALTY ITEMS

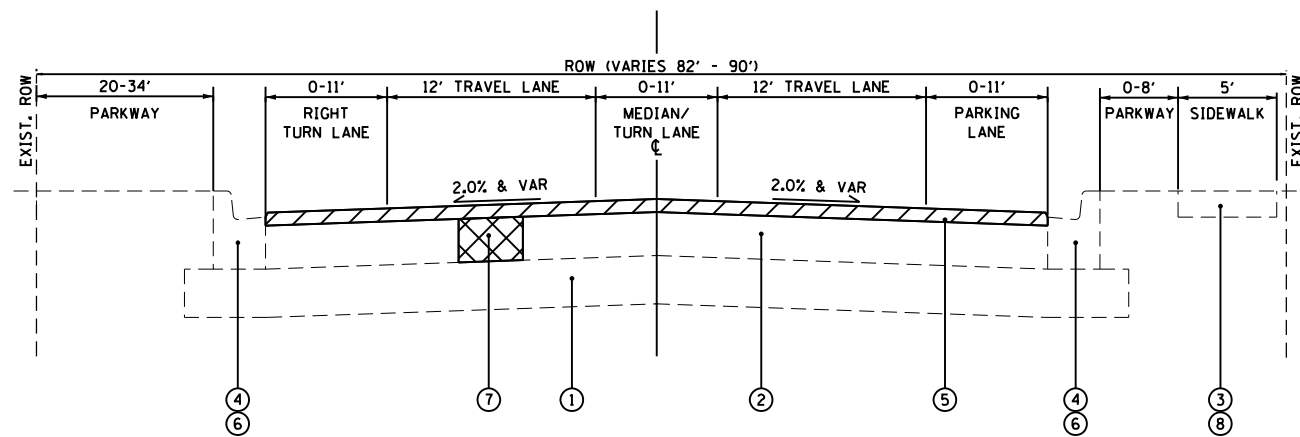

**EXISTING TYPICAL SECTION
STA. 10+30 TO STA. 29+81**

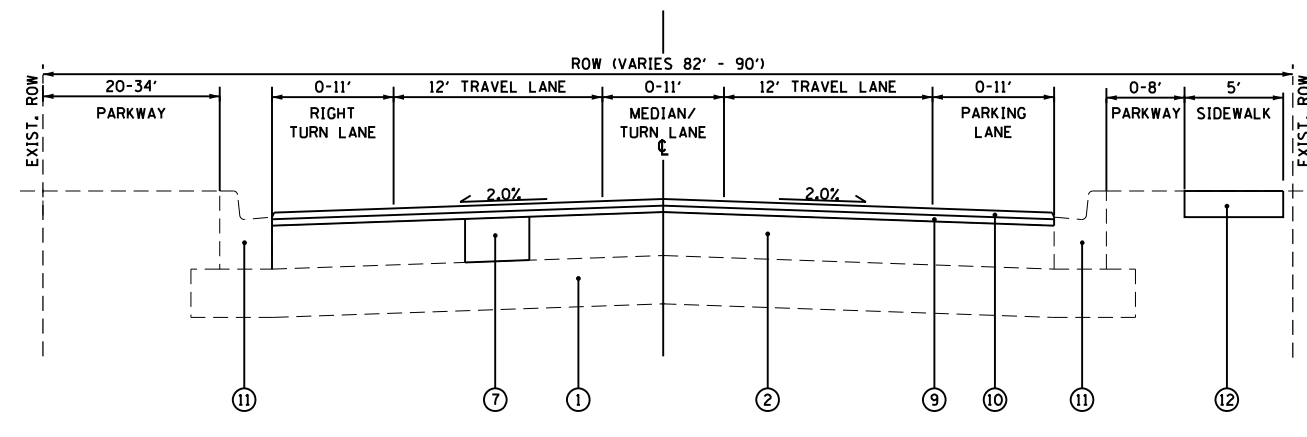

**PROPOSED TYPICAL SECTION
STA. 10+30 TO STA. 29+81**

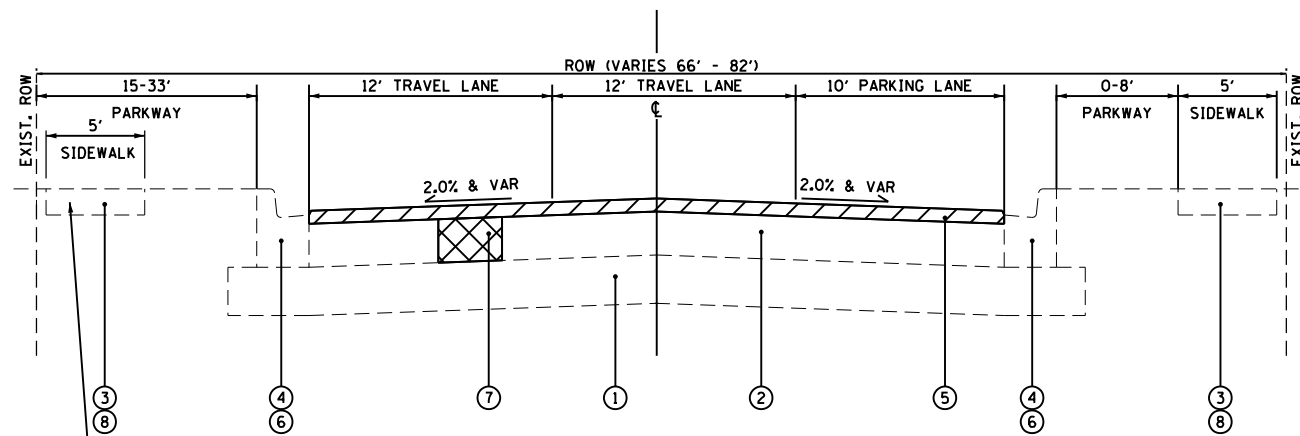

**EXISTING TYPICAL SECTION
STA. 29+81 TO STA. 46+16**

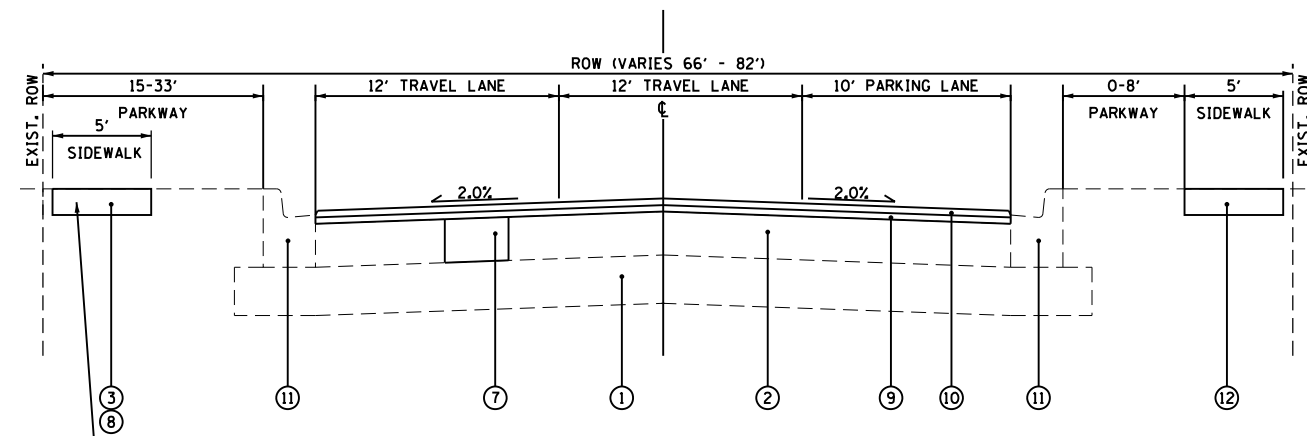

**PROPOSED TYPICAL SECTION
STA. 29+81 TO STA. 46+16**

LEGEND

- ① EX SUB-BASE GRAN MATL. THICKNESS VARIES
- ② EX HMA PAVEMENT
- ③ EX PCC SIDEWALK
- ④ EX COMB. CONC. CURB AND GUTTER
- ⑤ HMA SURFACE REMOVAL, 3"
- ⑥ COMB. CURB AND GUTTER REMOVAL (SEE NOTE 1)
- ⑦ PR CLASS D PATCHES, 7" (SEE NOTE 1)
- ⑧ PR SIDEWALK REMOVAL (SEE NOTE 1)
- ⑨ PR POLY. HMA BINDER COURSE, IL-4.75, N50, 1.0"
- ⑩ PR HMA SURFACE CRS, MIX "D", IL-9.5, N50, 2.0"
- ⑪ PR COMB. CONC. CURB AND GUTTER, TY B-6.12 (SEE NOTE 1)
- ⑫ PR P.C.C. SIDEWALK, 5" (SEE NOTE 1)

NOTES

1. LOCATIONS WILL BE SPECIFIED BY THE ENGINEER IN THE FIELD DURING CONSTRUCTION
2. PR AGG BASE COURSE IS INCLUDED IN THE PCC SIDEWALK PAY ITEM. SEE PROJECT SPECIFICATIONS FOR DETAILS

- REMOVAL ITEMS

HOT-MIX ASPHALT MIXTURE REQUIREMENTS

MIXTURE TYPE	AIR VOIDS @ Ndes
ROADWAY RESURFACING	
HOT-MIX ASPHALT SURFACE COURSE, MIX "D", IL-9.5, N50	4% @ 50 Gyr.
POLYMERIZED HOT-MIX ASPHALT BINDER COURSE, IL-4.75, N50	3.5% @ 50 Gyr.
CLASS D PATCHING	
HOT-MIX ASPHALT BINDER COURSE, IL-19.0, N70	4% @ 70 Gyr.
DRIVEWAYS	
HOT-MIX ASPHALT SURFACE COURSE, MIX "D", IL-9.5, N50; 1.5"	4% @ 50 Gyr.

1. THE UNIT WEIGHT USED TO CALCULATE ALL HMA SURFACE MIXTURE QUANTITIES IS 112 LBS/SQ YD/IN.
2. THE "AC TYPE" FOR POLYMERIZED HMA MIXES SHALL BE "SBS/SBR PG 76-22" AND FOR NON-POLYMERIZED HMA THE "AC TYPE" SHALL "PG 64-22" UNLESS MODIFIED BY DISTRICT ONE SPECIALS PROVISIONS.
3. FOR USE OF RECYCLED MATERIALS SEE SPECIAL PROVISIONS.

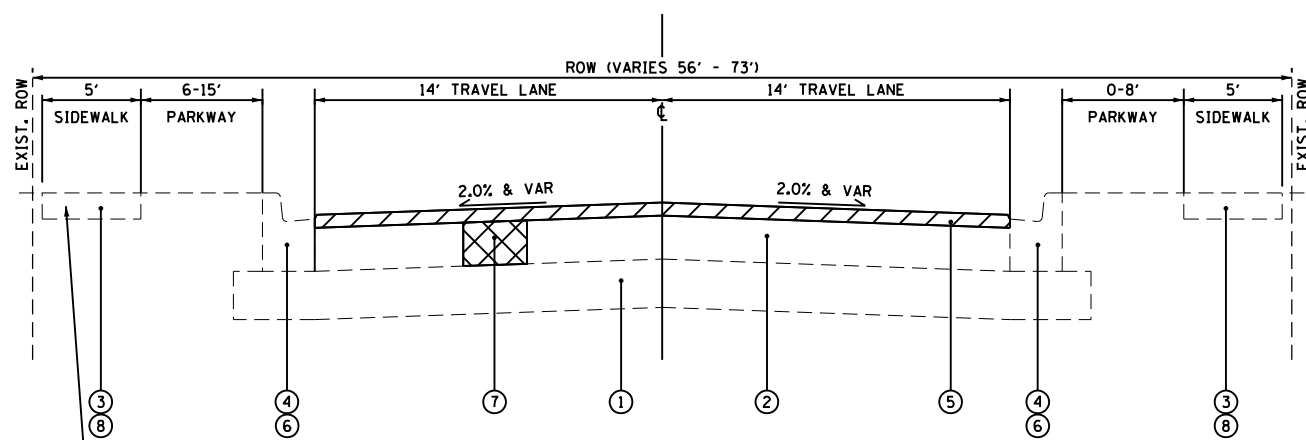

**EXISTING TYPICAL SECTION
STA. 46+16 TO STA. 73+80**

SIDEWALK BEGINS AT
STA. 43+86 AND
ENDS AT STA. 65+26

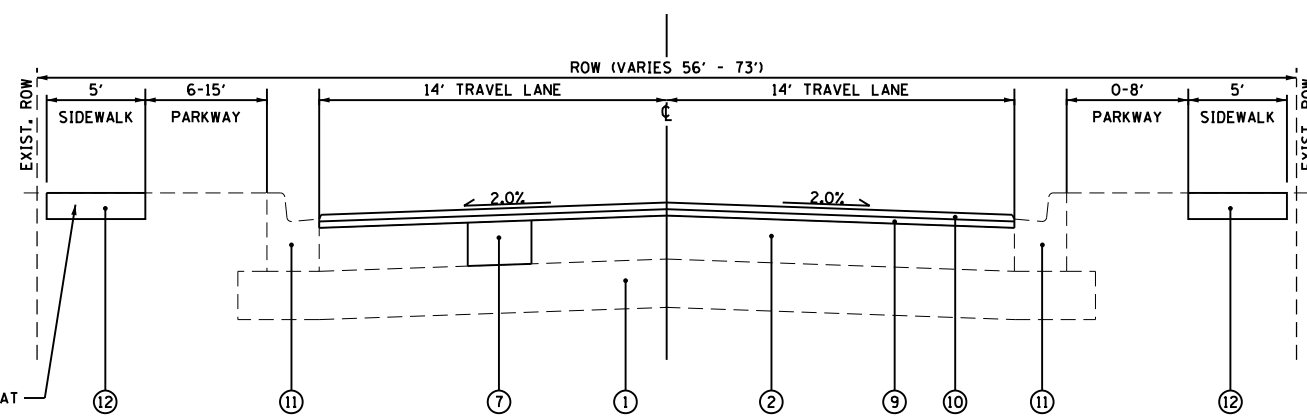

**PROPOSED TYPICAL SECTION
STA. 46+16 TO STA. 73+80**

SIDEWALK BEGINS AT
STA. 43+86 AND
ENDS AT STA. 65+26

LEGEND

- ① EX SUB-BASE GRAN MATL, THICKNESS VARIES
- ② EX HMA PAVEMENT
- ③ EX PCC SIDEWALK
- ④ EX COMB. CONC. CURB AND GUTTER
- ⑤ HMA SURFACE REMOVAL, 3"
- ⑥ COMB. CURB AND GUTTER REMOVAL (SEE NOTE 1)
- ⑦ PR CLASS D PATCHES, 7" (SEE NOTE 1)
- ⑧ PR SIDEWALK REMOVAL (SEE NOTE 1)
- ⑨ PR POLY. HMA BINDER COURSE, IL-4.75, N50, 1.0"
- ⑩ PR HMA SURFACE CRS, MIX "D", IL-9.5, N50, 2.0"
- ⑪ PR COMB. CONC. CURB AND GUTTER, TY B-6.12 (SEE NOTE 1)
- ⑫ PR P.C.C. SIDEWALK, 5" (SEE NOTE 1)

NOTES

1. LOCATIONS WILL BE SPECIFIED BY THE ENGINEER IN THE FIELD DURING CONSTRUCTION
2. PR AGG BASE COURSE IS INCLUDED IN THE PCC SIDEWALK PAY ITEM. SEE PROJECT SPECIFICATIONS FOR DETAILS

- REMOVAL ITEMS

USER NAME = maciej.k	DESIGNED -	REVISED -
PLOT SCALE = 2.0000' / 1" =	DRAWN -	REVISED -
PLOT DATE = 12/19/2019	CHECKED -	REVISED -
	DATE -	REVISED -

F.A.U. RTE.	SECTION	COUNTY	TOTAL SHEETS	SHEET NO.
3549	19-00121-00-RS	DuPAGE	35	6
CONTRACT:			61G23	
ILLINOIS FED. AID PROJECT				

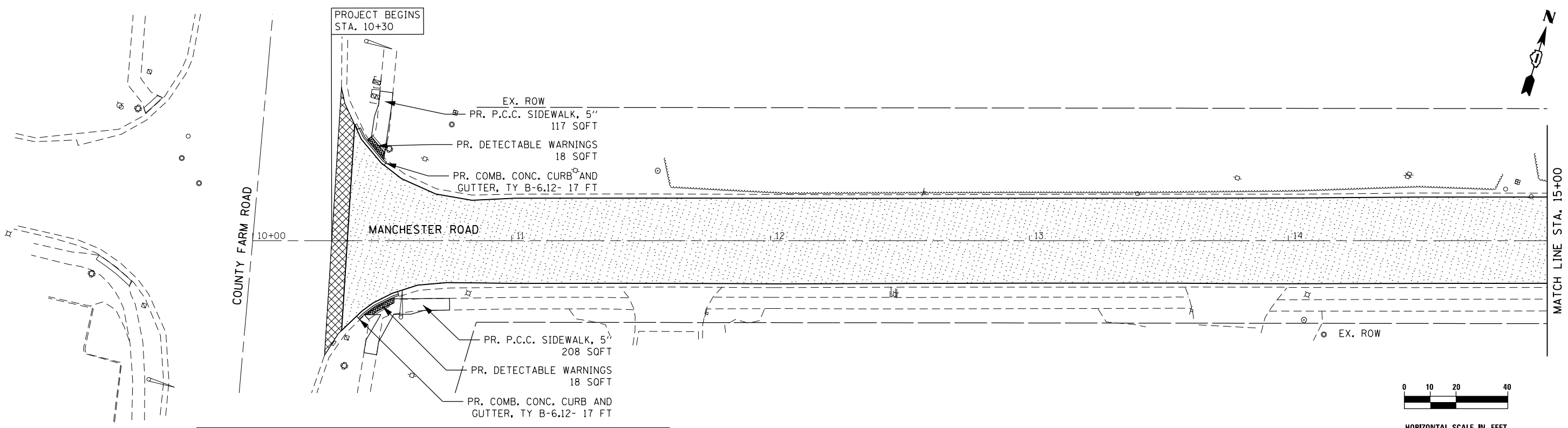

- NOTES:**
- FOR SIDEWALK DETAILS, SEE SHEETS 19-23
 - ANY NECESSARY TYPE B CURB FOR MEETING ADA RAMP GRADES AT THE BACK OF SIDEWALK SHALL BE POURED MONOLITHICALLY WITH THE SIDEWALK AND INCLUDED IN THE COST OF THE SIDEWALK.
 - A MINIMUM TRANSITION OF 18" WILL BE USED FROM DEPRESSED CURB TO FULL CURB HEIGHT (TYP).
 - FOR PRIVATE UTILITY ADJUSTMENTS, SEE GENERAL NOTES SHEET 2

LEGEND

	HMA SURFACE REMOVAL, 3"		PR. STRUCTURE TO BE ADJUSTED
	PR. POLY. HMA BINDER COURSE, IL-4.75, N50, 1.0"	A	SANITARY MH
	PR. HMA SURFACE COURSE, MIX "D", IL-9.5, N50, 2.0"	B	STORM MH
	PR. HMA SURFACE REMOVAL- BUTT JOINT	C	STORM INLET
	EX. PCC SIDEWALK REMOVAL, PR. TOPSOIL AND SOD	D	STORM CB
			PR. STRUCTURE TO BE ADJUSTED WITH NEW FRAME AND GRATE OR LID (OF TYPE SPECIFIED)
		TY XX	

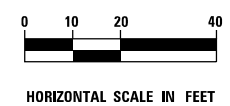
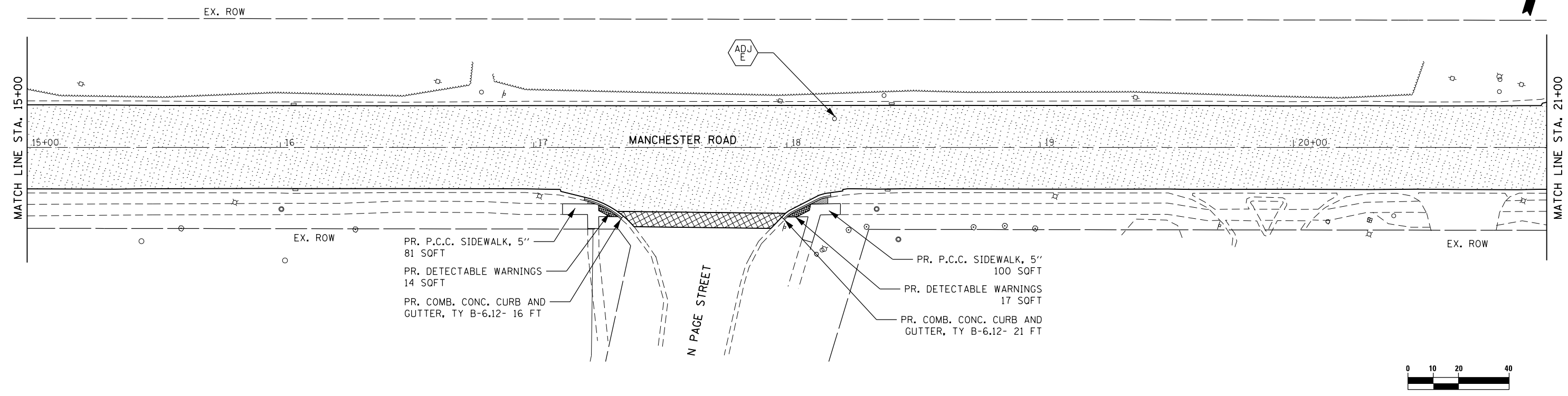
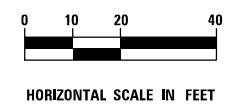

thomas
 thomas engineering group, llc
 762 shoreline drive
 suite 200
 aurora, illinois 60504
 phone: 855-533-1700

USER NAME = maciejk	DESIGNED -	REVISED -
PLOT SCALE = 40.0000' / in.	DRAWN -	REVISED -
PLOT DATE = 12/19/2019	CHECKED -	REVISED -
	DATE -	REVISED -

**STATE OF ILLINOIS
 DEPARTMENT OF TRANSPORTATION**

ROADWAY PLANS

SCALE: SHEET OF SHEETS STA. TO STA.

F.A.U. RTE.	SECTION	COUNTY	TOTAL SHEETS	SHEET NO.
3549	19-00121-00-RS	DuPAGE	35	7
CONTRACT:			61G23	
ILLINOIS FED. AID PROJECT				

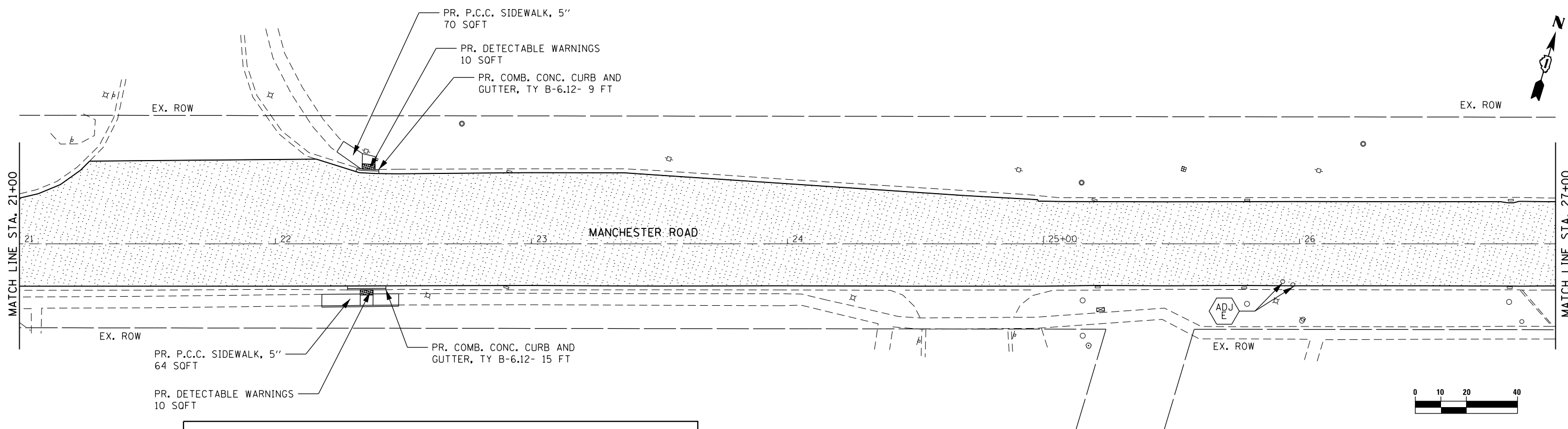

- NOTES:**
- FOR SIDEWALK DETAILS, SEE SHEETS 19-23
 - ANY NECESSARY TYPE B CURB FOR MEETING ADA RAMP GRADES AT THE BACK OF SIDEWALK SHALL BE POURED MONOLITHICALLY WITH THE SIDEWALK AND INCLUDED IN THE COST OF THE SIDEWALK.
 - A MINIMUM TRANSITION OF 18" WILL BE USED FROM DEPRESSED CURB TO FULL CURB HEIGHT (TYP).
 - FOR PRIVATE UTILITY ADJUSTMENTS, SEE GENERAL NOTES SHEET 2

LEGEND

	HMA SURFACE REMOVAL, 3"		PR. STRUCTURE TO BE ADJUSTED
	PR. POLY. HMA BINDER COURSE, IL-4.75, N50, 1.0"	A -	SANITARY MH
	PR. HMA SURFACE COURSE, MIX "D", IL-9.5 N50, 2.0"	B -	STORM MH
	PR. HMA SURFACE REMOVAL- BUTT JOINT	C -	STORM INLET
	EX. PCC SIDEWALK REMOVAL, PR. TOPSOIL AND SOD	D -	STORM CB
			PR. STRUCTURE TO BE ADJUSTED WITH NEW FRAME AND GRATE OR LID (OF TYPE SPECIFIED)

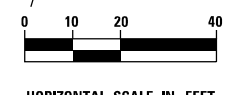
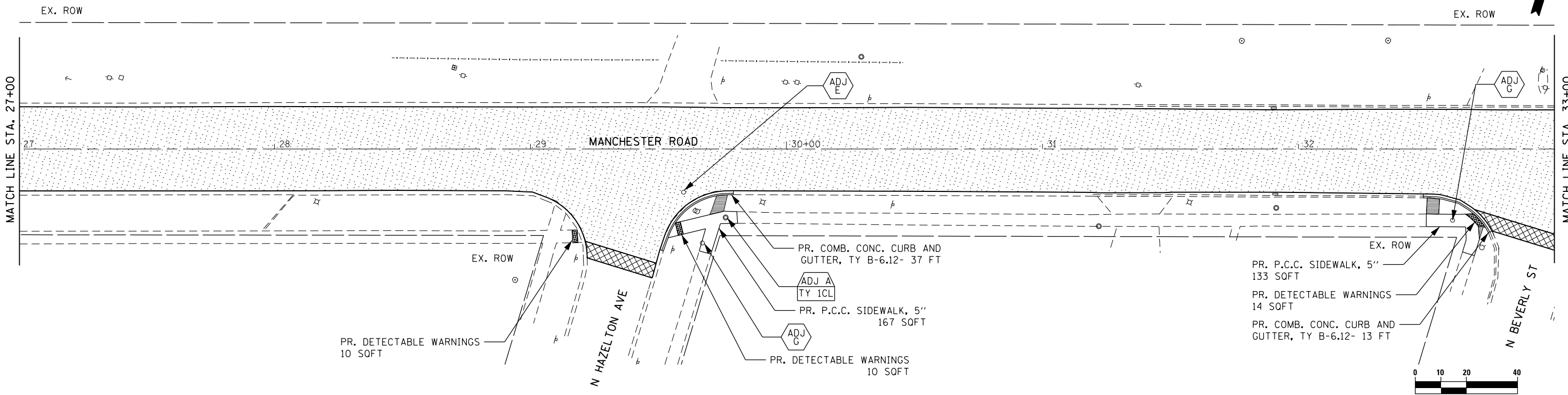
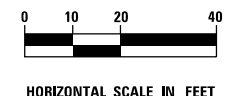

thomas
 thomas engineering group, llc
 762 shoreline drive
 suite 200
 aurora, illinois 60504
 phone: 855-533-1700

USER NAME = maciej.k	DESIGNED -	REVISED -
PLOT SCALE = 40.0000' / in.	DRAWN -	REVISED -
PLOT DATE = 12/20/2019	CHECKED -	REVISED -
	DATE -	REVISED -

**STATE OF ILLINOIS
 DEPARTMENT OF TRANSPORTATION**

ROADWAY PLANS

SCALE: SHEET OF SHEETS STA. TO STA.

F.A.U. RTE.	SECTION	COUNTY	TOTAL SHEETS	SHEET NO.
3549	19-00121-00-RS	DuPAGE	35	8
CONTRACT:			61G23	
ILLINOIS FED. AID PROJECT				

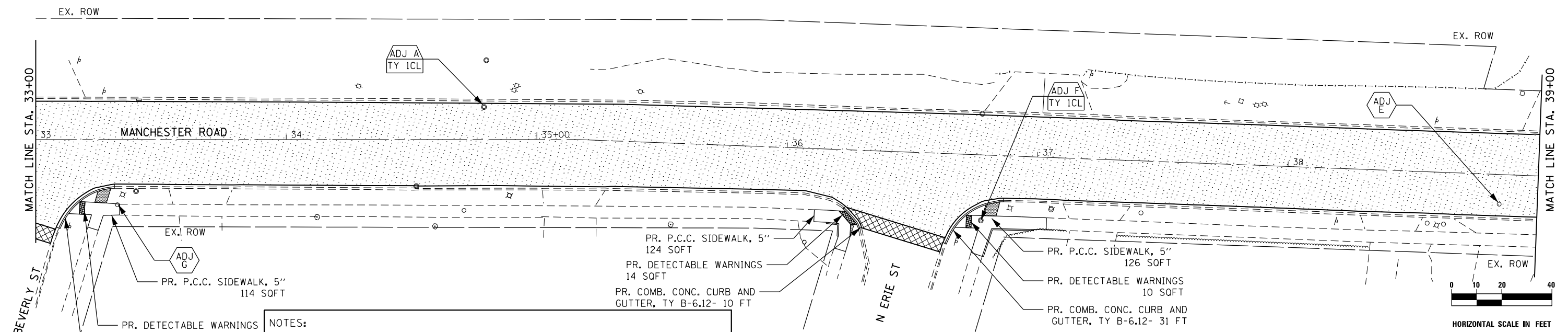

PR. P.C.C. SIDEWALK, 5"
114 SQFT

PR. DETECTABLE WARNINGS
10 SQFT

PR. COMB. CONC. CURB AND
GUTTER, TY B-6.12- 28 FT

- NOTES:**
- FOR SIDEWALK DETAILS, SEE SHEETS 19-23
 - ANY NECESSARY TYPE B CURB FOR MEETING ADA RAMP GRADES AT THE BACK OF SIDEWALK SHALL BE POURED MONOLITHICALLY WITH THE SIDEWALK AND INCLUDED IN THE COST OF THE SIDEWALK.
 - A MINIMUM TRANSITION OF 18" WILL BE USED FROM DEPRESSED CURB TO FULL CURB HEIGHT (TYP).
 - FOR PRIVATE UTILITY ADJUSTMENTS, SEE GENERAL NOTES SHEET 2

PR. P.C.C. SIDEWALK, 5"
124 SQFT

PR. DETECTABLE WARNINGS
14 SQFT

PR. COMB. CONC. CURB AND
GUTTER, TY B-6.12- 10 FT

PR. P.C.C. SIDEWALK, 5"
126 SQFT

PR. DETECTABLE WARNINGS
10 SQFT

PR. COMB. CONC. CURB AND
GUTTER, TY B-6.12- 31 FT

LEGEND

	HMA SURFACE REMOVAL, 3" PR. POLY. HMA BINDER COURSE, IL-4.75, N50, 1.0" PR. HMA SURFACE COURSE, MIX "D", IL-9.5, N50, 2.0"		PR. STRUCTURE TO BE ADJUSTED A - SANITARY MH E - WATER VALVE B - STORM MH F - WATER MH C - STORM INLET G - GAS VALVE D - STORM CB
	PR. HMA SURFACE REMOVAL- BUTT JOINT		PR. STRUCTURE TO BE ADJUSTED WITH NEW FRAME AND GRATE OR LID (OF TYPE SPECIFIED)
	EX. PCC SIDEWALK REMOVAL, PR. TOPSOIL AND SOD		

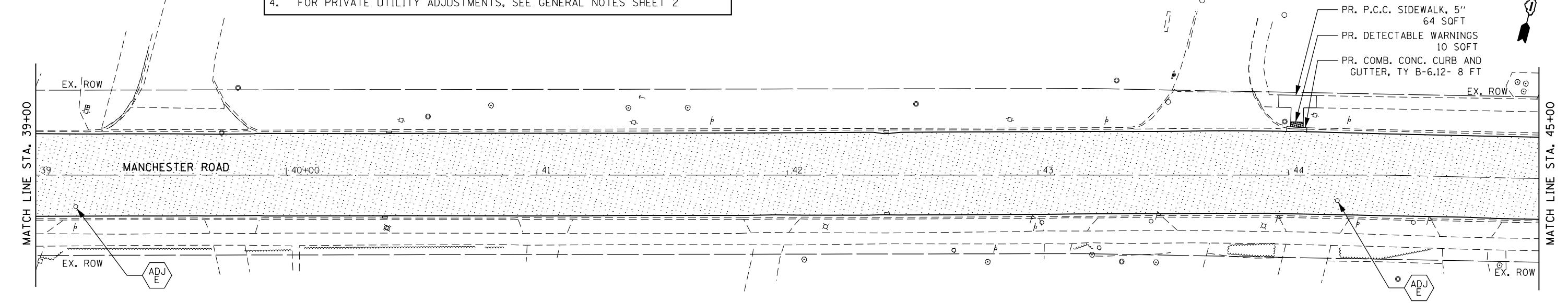

PR. P.C.C. SIDEWALK, 5"
64 SQFT

PR. DETECTABLE WARNINGS
10 SQFT

PR. COMB. CONC. CURB AND
GUTTER, TY B-6.12- 8 FT

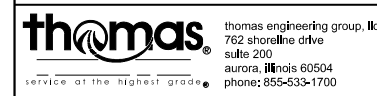

USER NAME = maciej	DESIGNED -	REVISED -
PLOT SCALE = 40.0000' / in.	DRAWN -	REVISED -
PLOT DATE = 12/19/2019	CHECKED -	REVISED -
	DATE -	REVISED -

**STATE OF ILLINOIS
DEPARTMENT OF TRANSPORTATION**

ROADWAY PLANS

SCALE:	SHEET	OF	SHEETS	STA.	TO	STA.
--------	-------	----	--------	------	----	------

F.A.U. RTE.	SECTION	COUNTY	TOTAL SHEETS	SHEET NO.
3549	19-00121-00-RS	DuPAGE	35	9
CONTRACT:			61G23	
ILLINOIS FED. AID PROJECT				

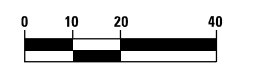

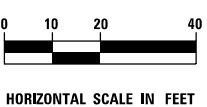
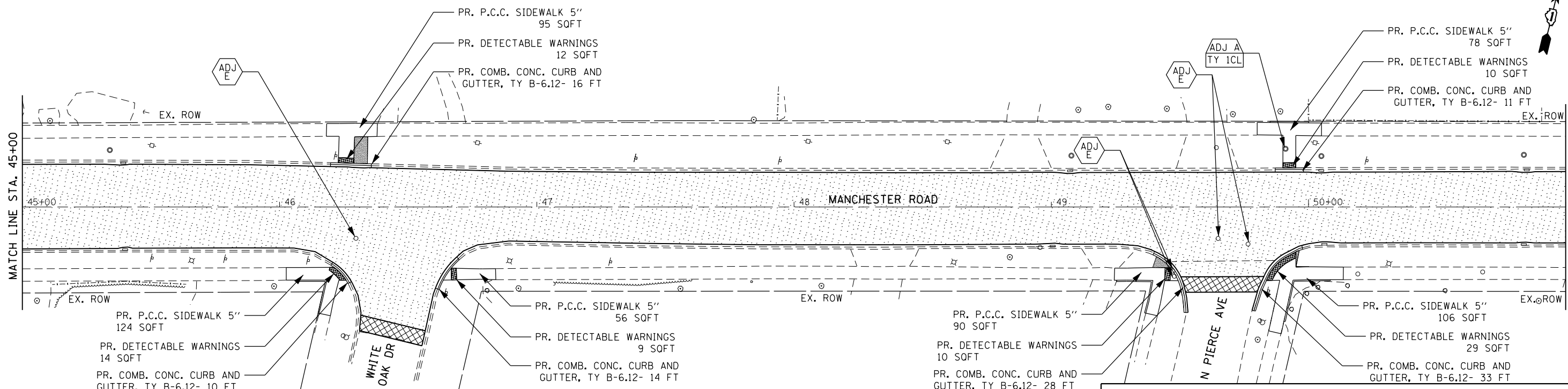

LEGEND

	HMA SURFACE REMOVAL, 3"		PR. STRUCTURE TO BE ADJUSTED
	PR. POLY. HMA BINDER COURSE, IL-4.75, N50, 1.0"	A - SANITARY MH	E - WATER VALVE
	PR. HMA SURFACE COURSE, MIX "D", IL-9.5, N50, 2.0"	B - STORM MH	F - WATER MH
	PR. HMA SURFACE REMOVAL- BUTT JOINT	C - STORM INLET	G - GAS VALVE
	EX. PCC SIDEWALK REMOVAL, PR. TOPSOIL AND SOD	D - STORM CB	
			PR. STRUCTURE TO BE ADJUSTED WITH NEW FRAME AND GRATE OR LID (OF TYPE SPECIFIED)

- NOTES:**
- FOR SIDEWALK DETAILS, SEE SHEETS 19-23
 - ANY NECESSARY TYPE B CURB FOR MEETING ADA RAMP GRADES AT THE BACK OF SIDEWALK SHALL BE POURED MONOLITHICALLY WITH THE SIDEWALK AND INCLUDED IN THE COST OF THE SIDEWALK.
 - A MINIMUM TRANSITION OF 18" WILL BE USED FROM DEPRESSED CURB TO FULL CURB HEIGHT (TYP).
 - FOR PRIVATE UTILITY ADJUSTMENTS, SEE GENERAL NOTES SHEET 2

HORIZONTAL SCALE IN FEET

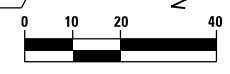
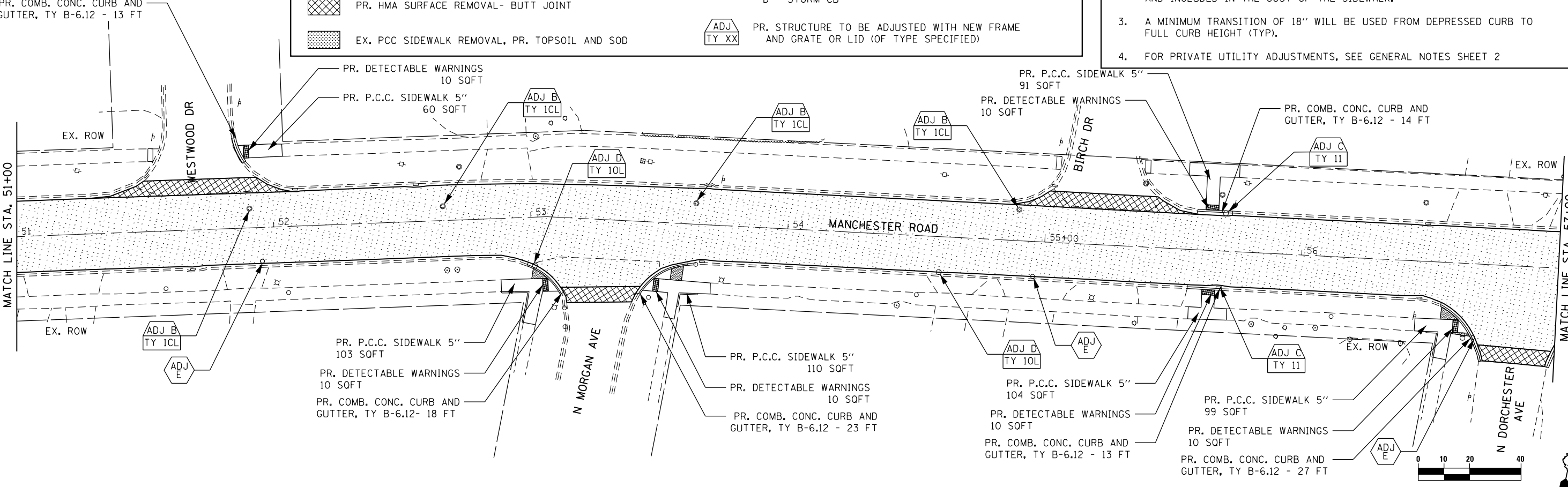

thomas engineering group, llc
 762 shoreline drive
 suite 200
 aurora, illinois 60504
 phone: 855-533-1700

USER NAME = maciej.k	DESIGNED -	REVISED -
PLOT SCALE = 40.0000' / in.	DRAWN -	REVISED -
PLOT DATE = 12/19/2019	CHECKED -	REVISED -
	DATE -	REVISED -

**STATE OF ILLINOIS
 DEPARTMENT OF TRANSPORTATION**

ROADWAY PLANS

SCALE: SHEET OF SHEETS STA. TO STA.

F.A.U. RTÉ.	SECTION	COUNTY	TOTAL SHEETS	SHEET NO.
3549	19-00121-00-R5	DuPAGE	35	10
CONTRACT:			61G23	
ILLINOIS FED. AID PROJECT				

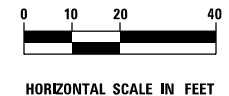
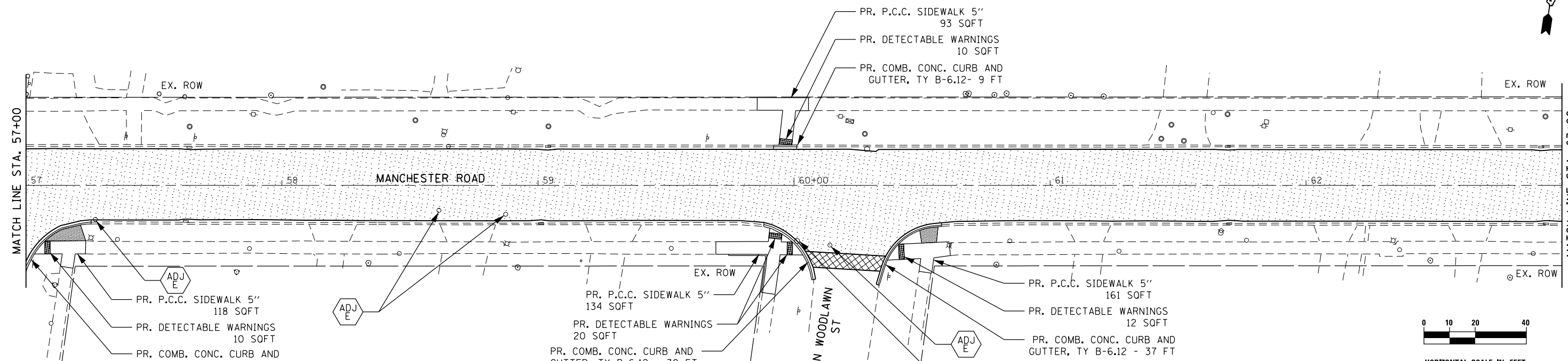

LEGEND

	HMA SURFACE REMOVAL, 3"		PR. STRUCTURE TO BE ADJUSTED
	PR. POLY. HMA BINDER COURSE, IL-4.75, N50, 1.0"	A	SANITARY MH
	PR. HMA SURFACE COURSE, MIX "D", IL-9.5, N50, 2.0"	B	STORM MH
	PR. HMA SURFACE REMOVAL- BUTT JOINT	C	STORM INLET
	EX. PCC SIDEWALK REMOVAL, PR. TOPSOIL AND SOD	D	STORM CB
			PR. STRUCTURE TO BE ADJUSTED WITH NEW FRAME AND GRATE OR LID (OF TYPE SPECIFIED)

- NOTES:**
- FOR SIDEWALK DETAILS, SEE SHEETS 19-23
 - ANY NECESSARY TYPE B CURB FOR MEETING ADA RAMP GRADES AT THE BACK OF SIDEWALK SHALL BE POURED MONOLITHICALLY WITH THE SIDEWALK AND INCLUDED IN THE COST OF THE SIDEWALK.
 - A MINIMUM TRANSITION OF 18" WILL BE USED FROM DEPRESSED CURB TO FULL CURB HEIGHT (TYP).
 - FOR PRIVATE UTILITY ADJUSTMENTS, SEE GENERAL NOTES SHEET 2

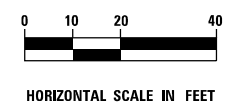
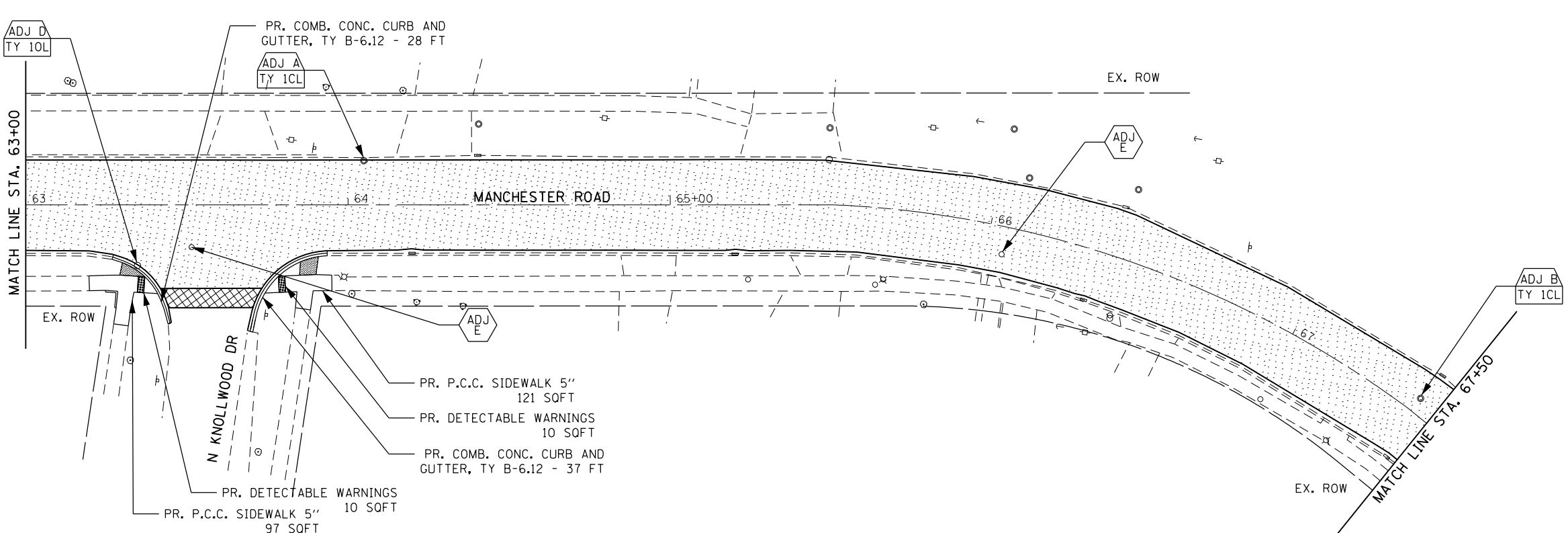

thomas thomas engineering group, llc
 762 shoreline drive
 suite 200
 aurora, illinois 60504
 phone: 855-533-1700

USER NAME = maciejk	DESIGNED -	REVISED -
PLOT SCALE = 40.0000' / in.	DRAWN -	REVISED -
PLOT DATE = 12/19/2019	CHECKED -	REVISED -
	DATE -	REVISED -

**STATE OF ILLINOIS
 DEPARTMENT OF TRANSPORTATION**

ROADWAY PLANS

SCALE: SHEET OF SHEETS STA. TO STA.

F.A.U. RTE.	SECTION	COUNTY	TOTAL SHEETS	SHEET NO.
3549	19-00121-00-RS	DuPAGE	35	11
CONTRACT:			61G23	
ILLINOIS FED. AID PROJECT				

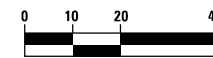
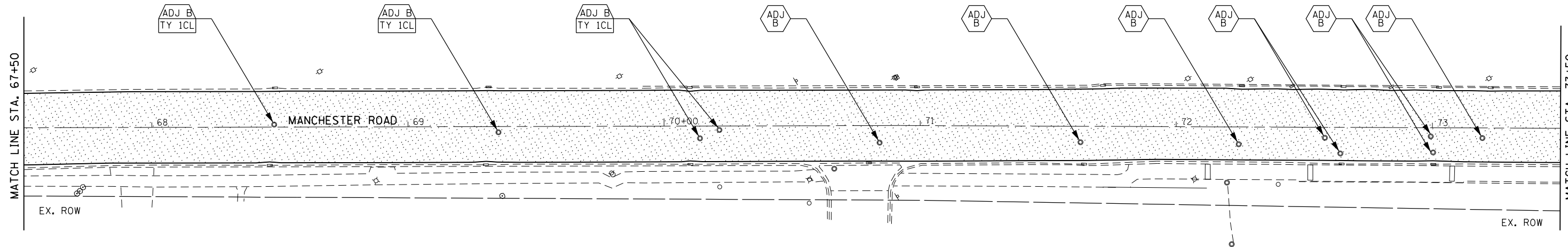

HORIZONTAL SCALE IN FEET

- NOTES:
- FOR SIDEWALK DETAILS, SEE SHEETS 19-23
 - ANY NECESSARY TYPE B CURB FOR MEETING ADA RAMP GRADES AT THE BACK OF SIDEWALK SHALL BE POURED MONOLITHICALLY WITH THE SIDEWALK AND INCLUDED IN THE COST OF THE SIDEWALK.
 - A MINIMUM TRANSITION OF 18" WILL BE USED FROM DEPRESSED CURB TO FULL CURB HEIGHT (TYP).
 - FOR PRIVATE UTILITY ADJUSTMENTS, SEE GENERAL NOTES SHEET 2

LEGEND

	HMA SURFACE REMOVAL, 3" PR. POLY. HMA BINDER COURSE, IL-4.75, N50, 1.0" PR. HMA SURFACE COURSE, MIX "D", IL-9.5, N50, 2.0"		PR. STRUCTURE TO BE ADJUSTED A - SANITARY MH E - WATER VALVE B - STORM MH F - WATER MH C - STORM INLET G - GAS VALVE D - STORM CB
	PR. HMA SURFACE REMOVAL- BUTT JOINT		PR. STRUCTURE TO BE ADJUSTED WITH NEW FRAME AND GRATE OR LID (OF TYPE SPECIFIED)
	EX. PCC SIDEWALK REMOVAL, PR. TOPSOIL AND SOD		

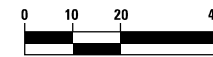
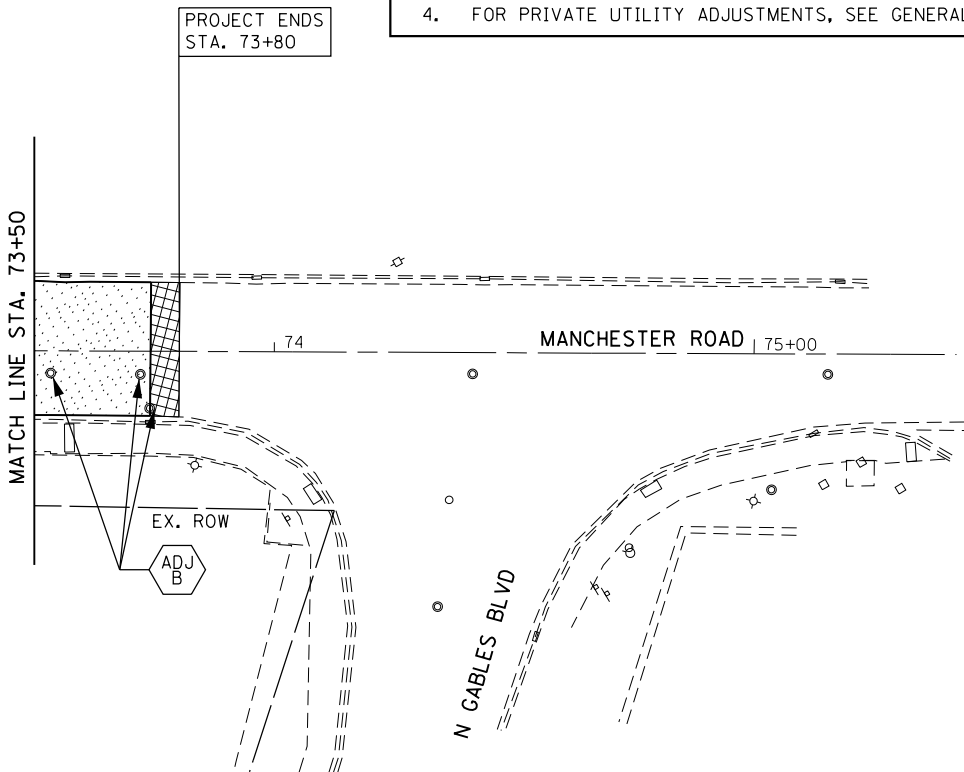

HORIZONTAL SCALE IN FEET

USER NAME = maciej.k	DESIGNED -	REVISED -
PLOT SCALE = 40.0000' / in.	DRAWN -	REVISED -
PLOT DATE = 12/19/2019	CHECKED -	REVISED -
	DATE -	REVISED -

F.A.U. RTE.	SECTION	COUNTY	TOTAL SHEETS	SHEET NO.
3549	19-00121-00-RS	DuPAGE	35	12
CONTRACT:			61G23	
ILLINOIS FED. AID PROJECT				

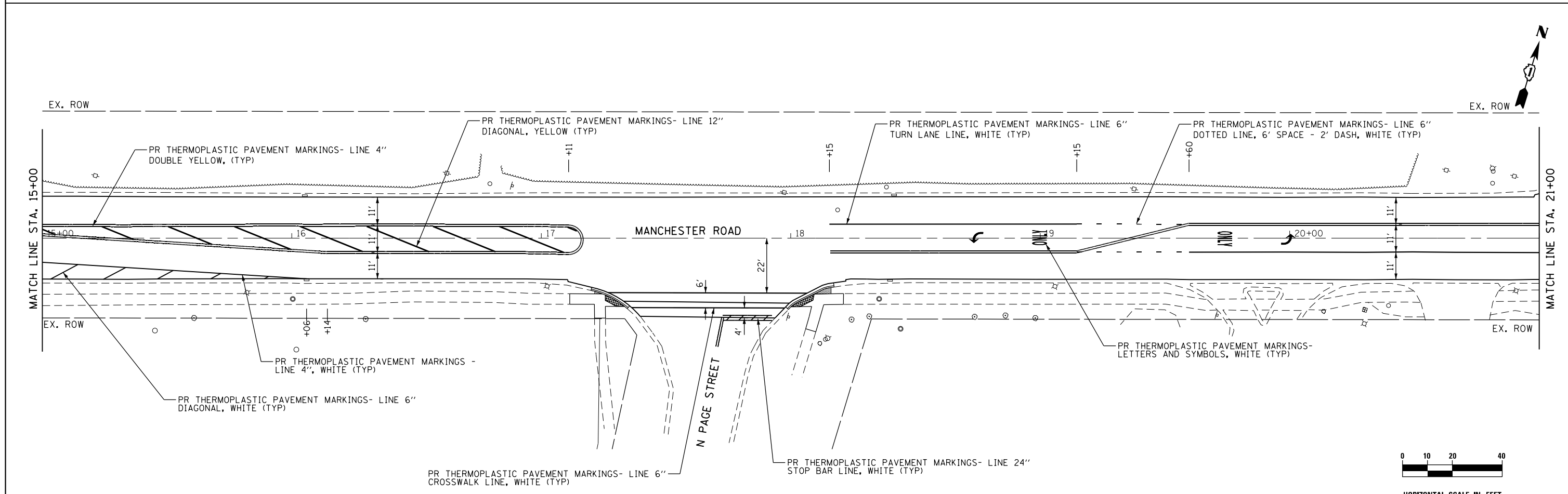
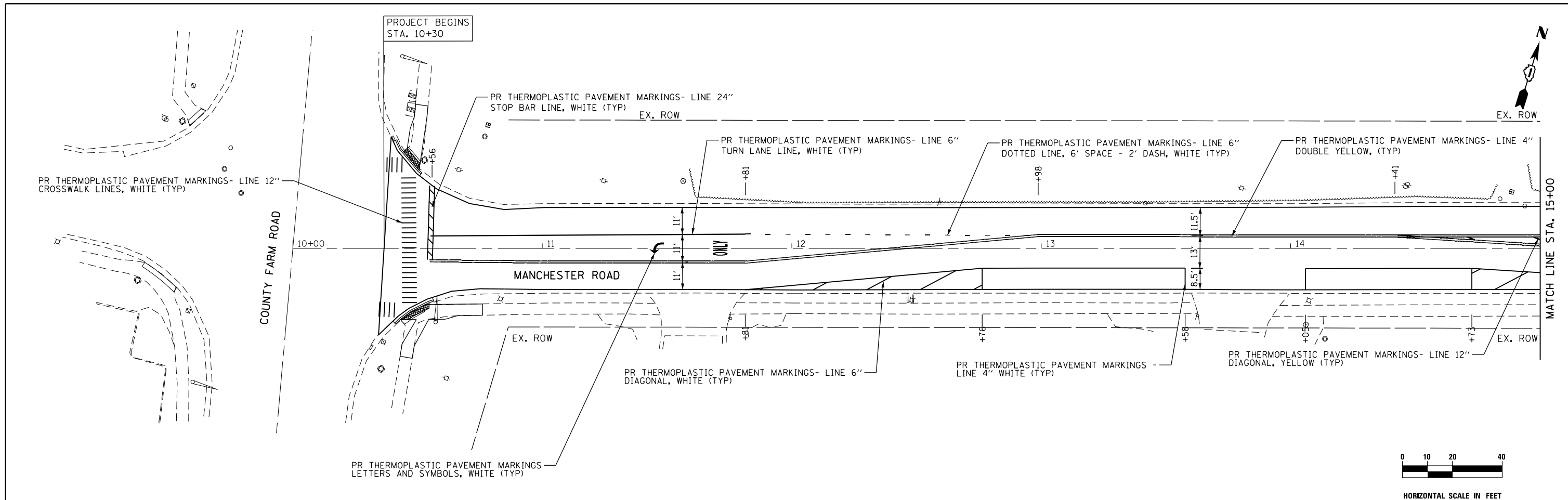

thomas engineering group, llc 762 shoreline drive suite 200 aurora, illinois 60504 phone: 855-533-1700	USER NAME = maciej.k	DESIGNED -	REVISED -	STATE OF ILLINOIS DEPARTMENT OF TRANSPORTATION	PAVEMENT MARKING PLANS			F.A.U. RTE.	SECTION	COUNTY	TOTAL SHEETS	SHEET NO.				
	PLOT SCALE = 40.0000' / in.	CHECKED -	REVISED -		SCALE:	SHEET	OF	SHEETS	STA.	TO	STA.	3549	19-00121-00-RS	DuPAGE	35	13
	PLOT DATE = 12/19/2019	DATE -	REVISED -											CONTRACT:	61G23	
														ILLINOIS FED. AID PROJECT		

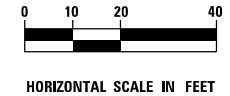
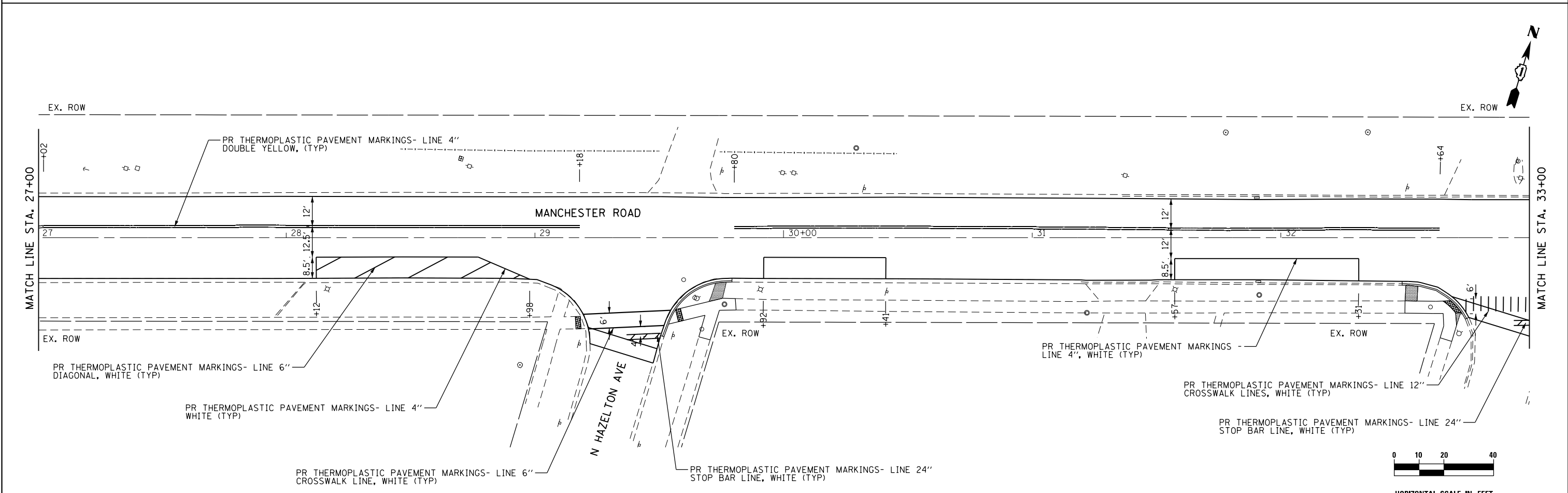
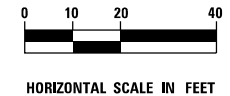
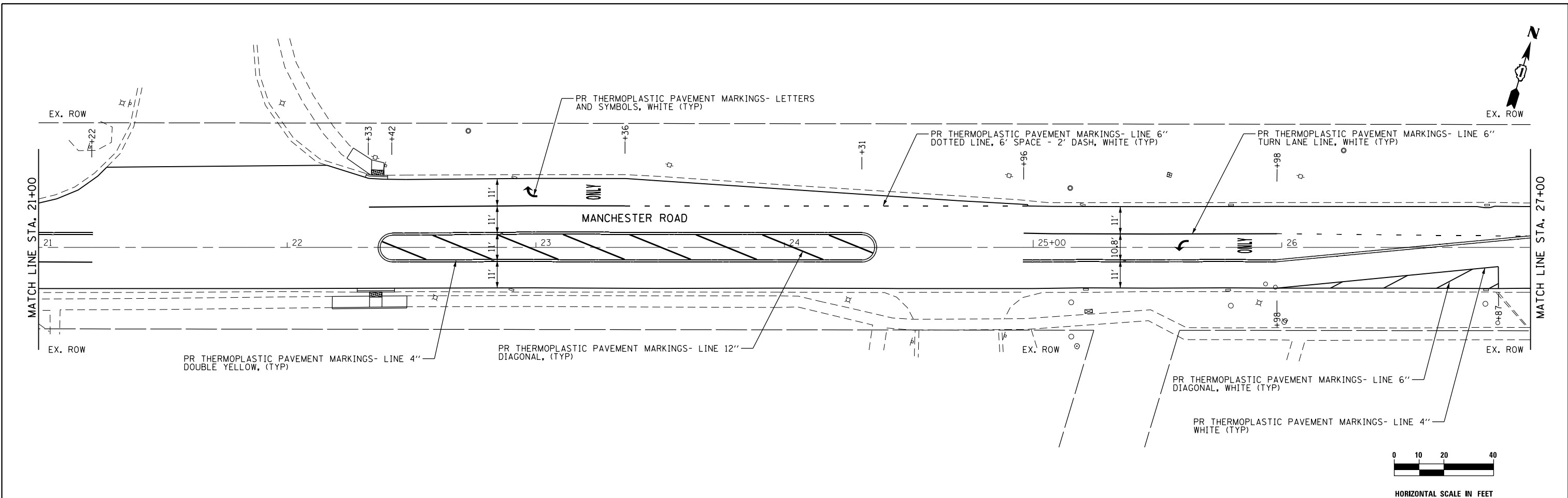

thomas
 thomas engineering group, llc
 762 shoreline drive
 suite 200
 aurora, illinois 60504
 phone: 855-533-1700

USER NAME = maciej.k	DESIGNED -	REVISED -
DRAWN -	REVISOR -	
PLOT SCALE = 40.0000' / in.	CHECKED -	REVISOR -
PLOT DATE = 12/19/2019	DATE -	REVISOR -

**STATE OF ILLINOIS
 DEPARTMENT OF TRANSPORTATION**

PAVEMENT MARKING PLANS	
SCALE:	SHEET OF SHEETS STA. TO STA.

F.A.U. RTE.	SECTION	COUNTY	TOTAL SHEETS	SHEET NO.
3549	19-00121-00-RS	DuPAGE	35	14
CONTRACT:			61G23	
ILLINOIS FED. AID PROJECT				

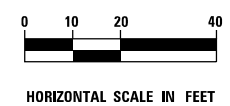
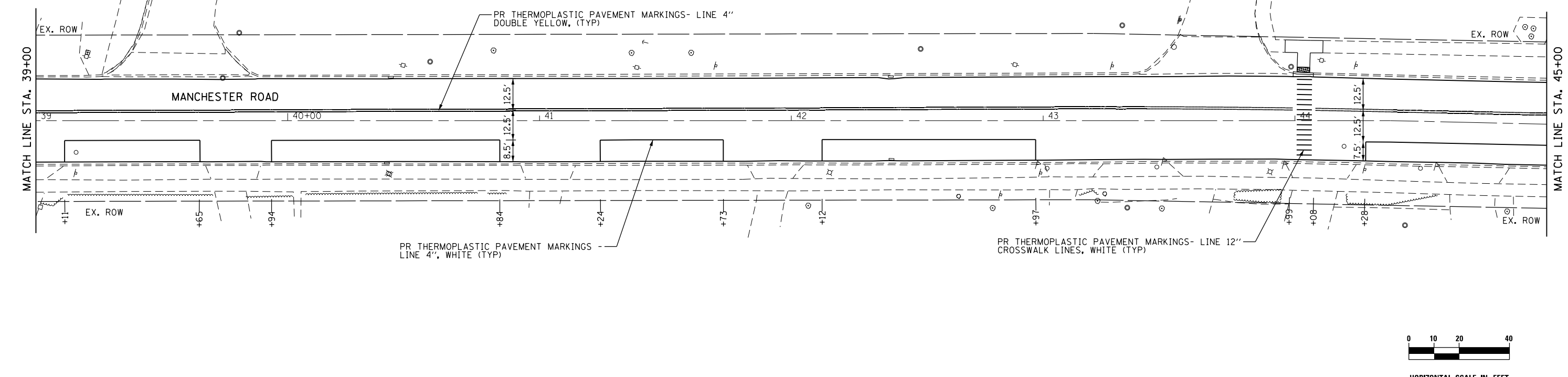
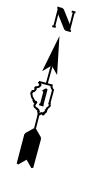
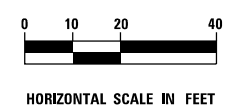
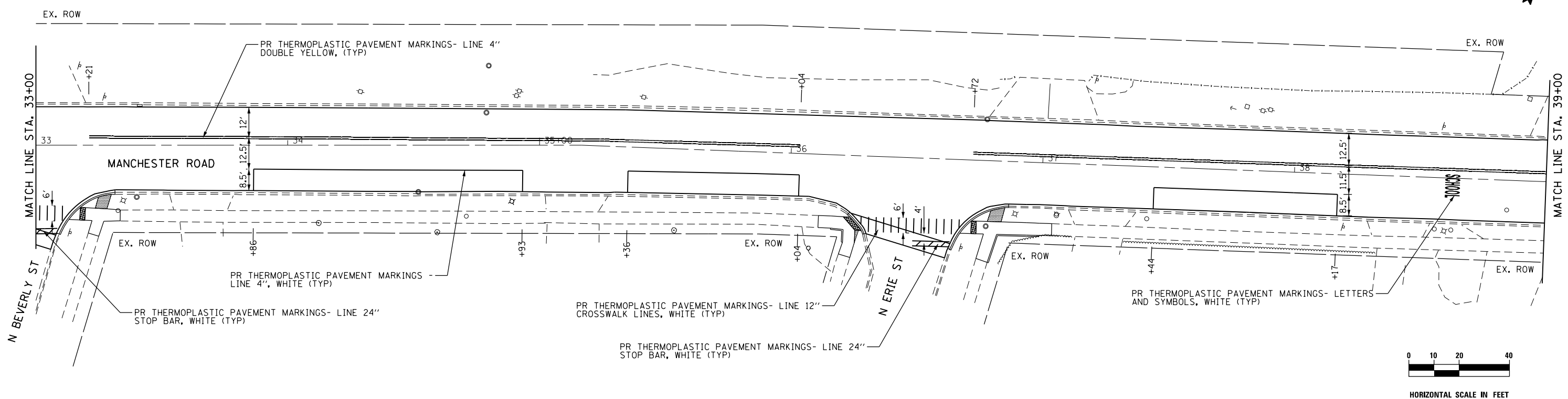

thomas
 thomas engineering group, llc
 762 shoreline drive
 suite 200
 aurora, illinois 60504
 phone: 855-533-1700

USER NAME = maciej.k	DESIGNED -	REVISED
PLOT SCALE = 40.0000' / in.	DRAWN -	REVISED -
PLOT DATE = 12/19/2019	CHECKED -	REVISED -
	DATE -	REVISED -

**STATE OF ILLINOIS
 DEPARTMENT OF TRANSPORTATION**

PAVEMENT MARKING PLANS	
SCALE:	SHEET OF SHEETS STA. TO STA.

F.A.U. RTE.	SECTION	COUNTY	TOTAL SHEETS	SHEET NO.
3549	19-00121-00-RS	DuPAGE	35	15
CONTRACT:			61G23	
ILLINOIS FED. AID PROJECT				

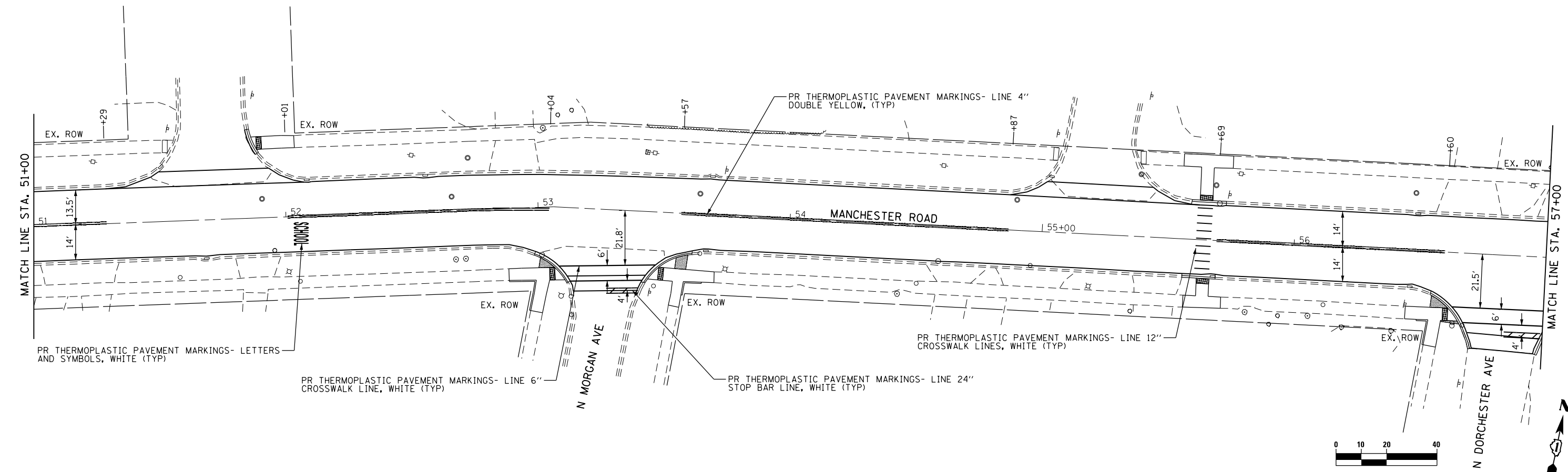
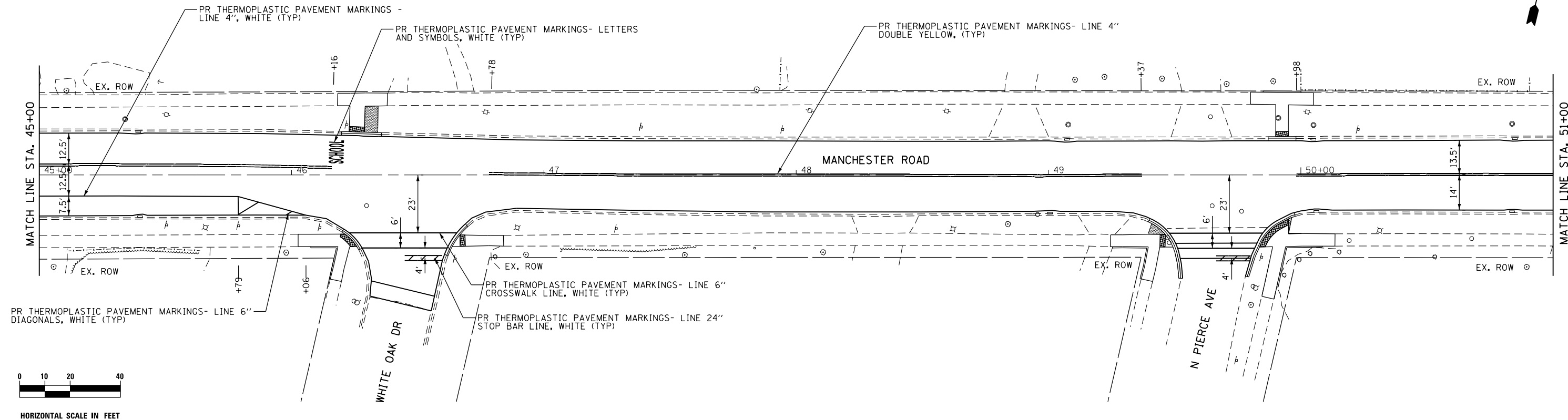

thomas
 thomas engineering group, llc
 762 shoreline drive
 suite 200
 aurora, illinois 60504
 phone: 855-533-1700

USER NAME = maciej.k	DESIGNED -	REVISED -
PLOT SCALE = 40.0000' / in.	DRAWN -	REVISED -
PLOT DATE = 12/19/2019	CHECKED -	REVISED -
	DATE -	REVISED -

**STATE OF ILLINOIS
 DEPARTMENT OF TRANSPORTATION**

PAVEMENT MARKING PLANS

SCALE: SHEET OF SHEETS STA. TO STA.

HORIZONTAL SCALE IN FEET

F.A.U. RTE.	SECTION	COUNTY	TOTAL SHEETS	SHEET NO.
3549	19-00121-00-RS	DuPAGE	35	16
CONTRACT:			61G23	
ILLINOIS FED. AID PROJECT				

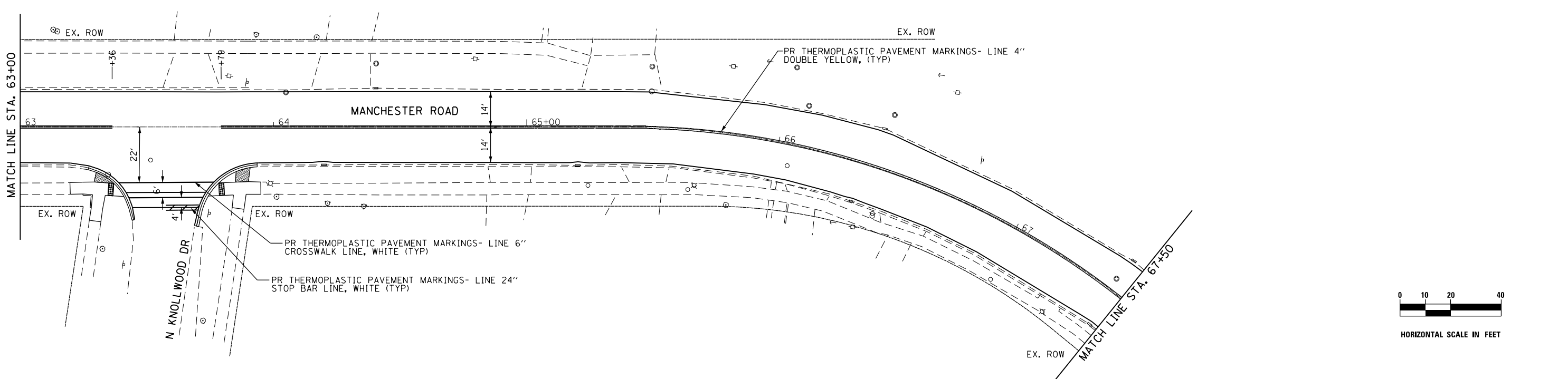
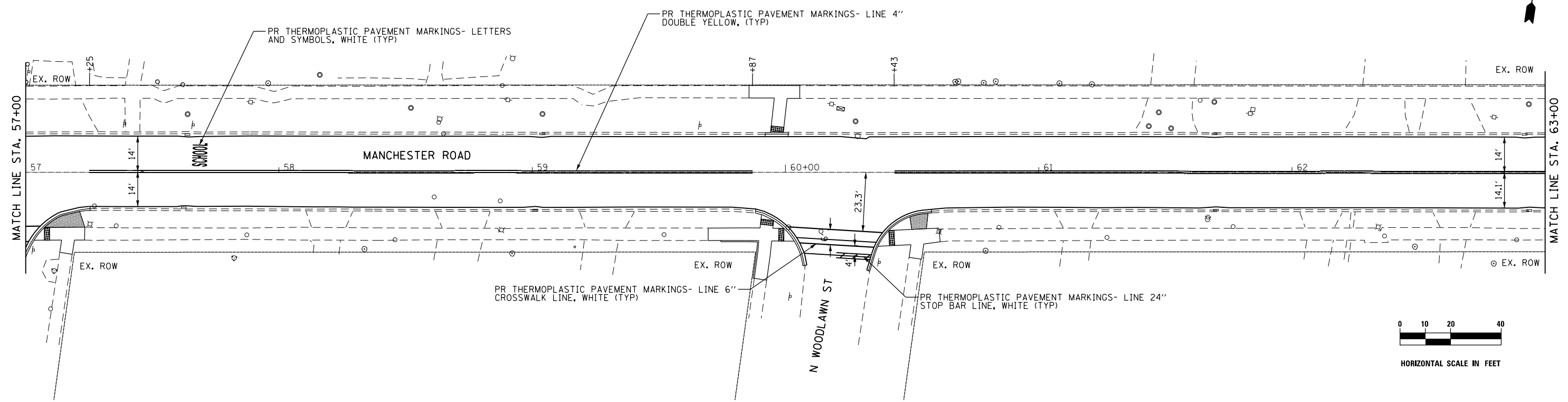

thomas
 thomas engineering group, llc
 762 shoreline drive
 suite 200
 aurora, illinois 60504
 phone: 855-533-1700

USER NAME = maciej.k	DESIGNED -	REVISED -
DRAWN -	REVISED -	
PLOT SCALE = 40.0000' / in.	CHECKED -	REVISED -
PLOT DATE = 12/19/2019	DATE -	REVISED -

**STATE OF ILLINOIS
 DEPARTMENT OF TRANSPORTATION**

PAVEMENT MARKING PLANS

SCALE: SHEET OF SHEETS STA. TO STA.

F.A.U. RTE.	SECTION	COUNTY	TOTAL SHEETS	SHEET NO.
3549	19-00121-00-RS	DuPAGE	35	17
CONTRACT:			61G23	

ILLINOIS FED. AID PROJECT

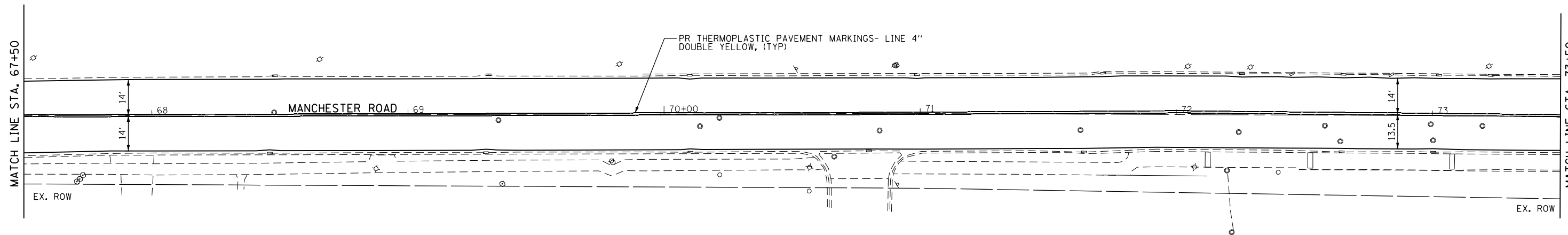

HORIZONTAL SCALE IN FEET

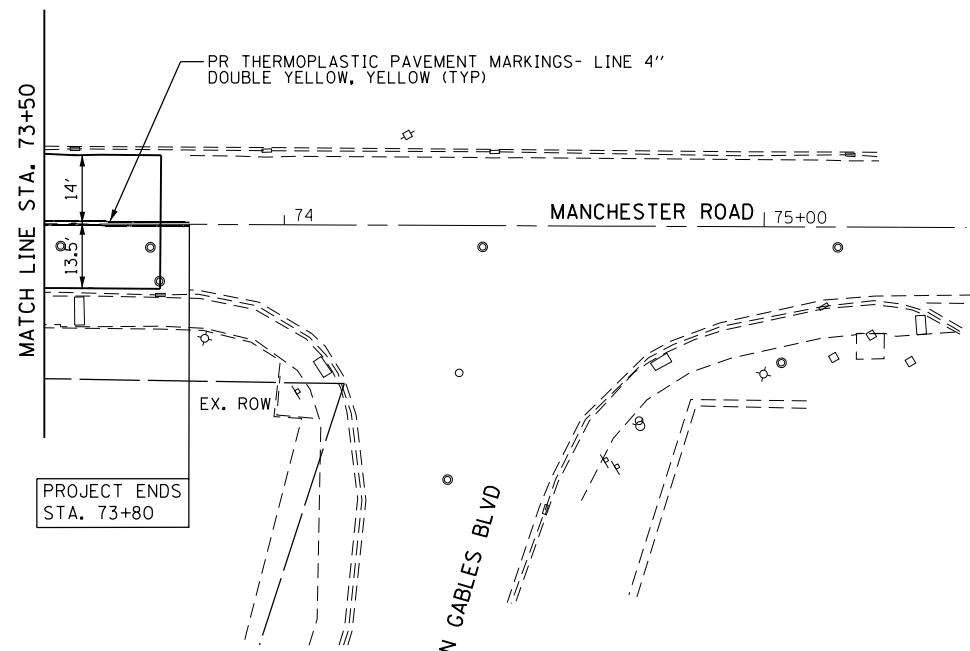
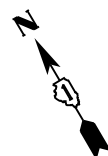

HORIZONTAL SCALE IN FEET

thomas
 thomas engineering group, llc
 762 shoreline drive
 suite 200
 aurora, illinois 60504
 phone: 855-533-1700

USER NAME = maciej.k	DESIGNED -	REVISED -
PLOT SCALE = 40.0000' / in.	DRAWN -	REVISED -
PLOT DATE = 12/19/2019	CHECKED -	REVISED -
	DATE -	REVISED -

**STATE OF ILLINOIS
 DEPARTMENT OF TRANSPORTATION**

PAVEMENT MARKING PLANS

SCALE: SHEET OF SHEETS STA. TO STA.

F.A.U. RTE.	SECTION	COUNTY	TOTAL SHEETS	SHEET NO.
3549	19-00121-00-RS		35	18
CONTRACT:			61G23	
ILLINOIS FED. AID PROJECT				

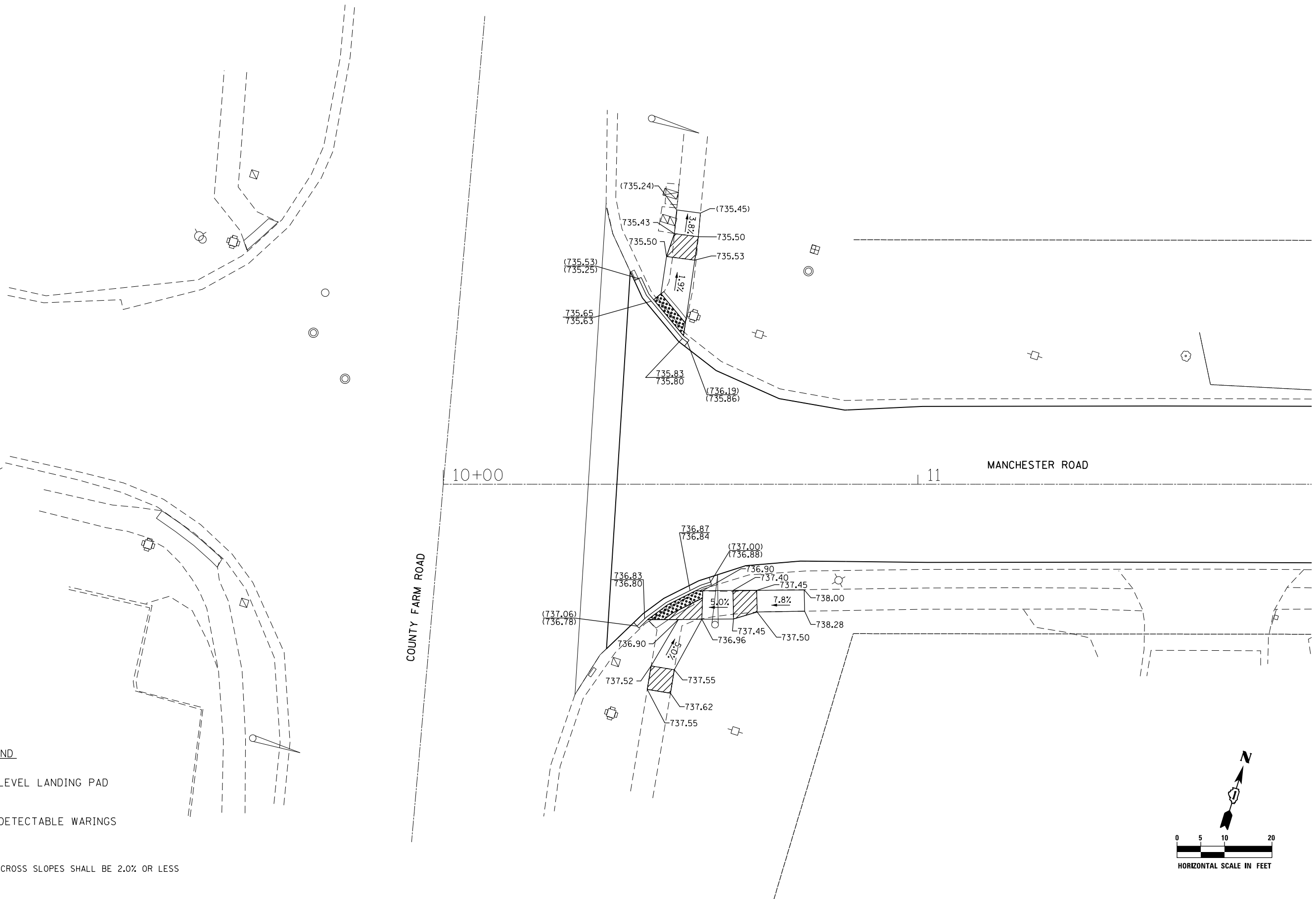

LEGEND



PR. LEVEL LANDING PAD



PR. DETECTABLE WARINGS

NOTE:

1. ALL SIDEWALK CROSS SLOPES SHALL BE 2.0% OR LESS

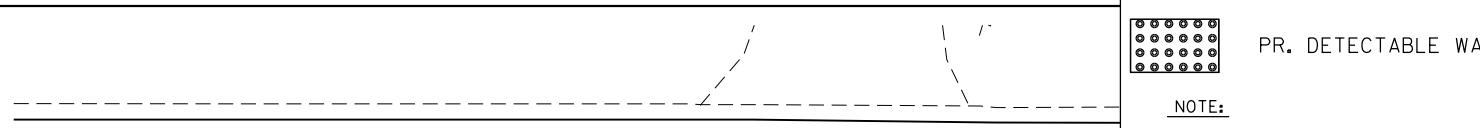
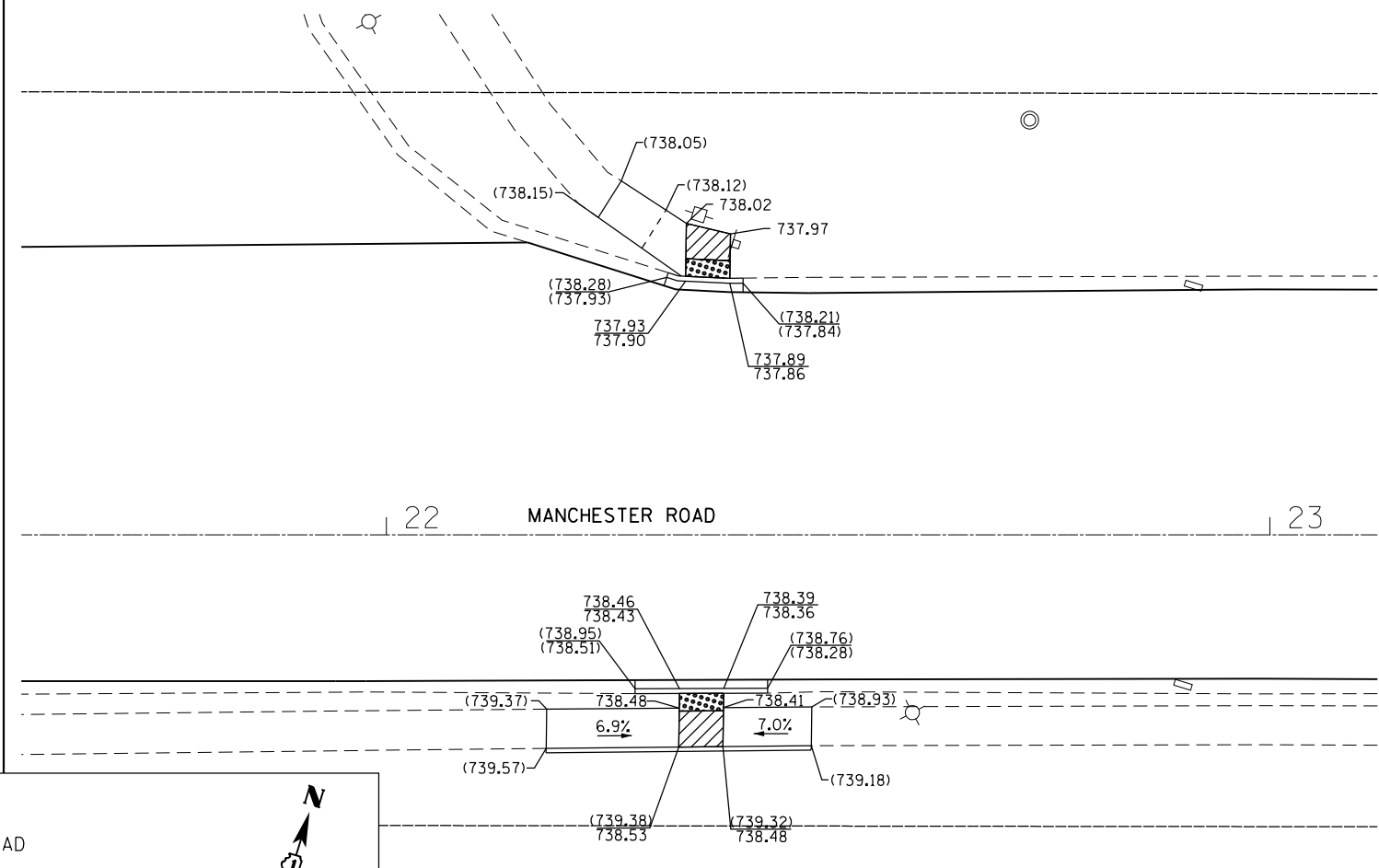
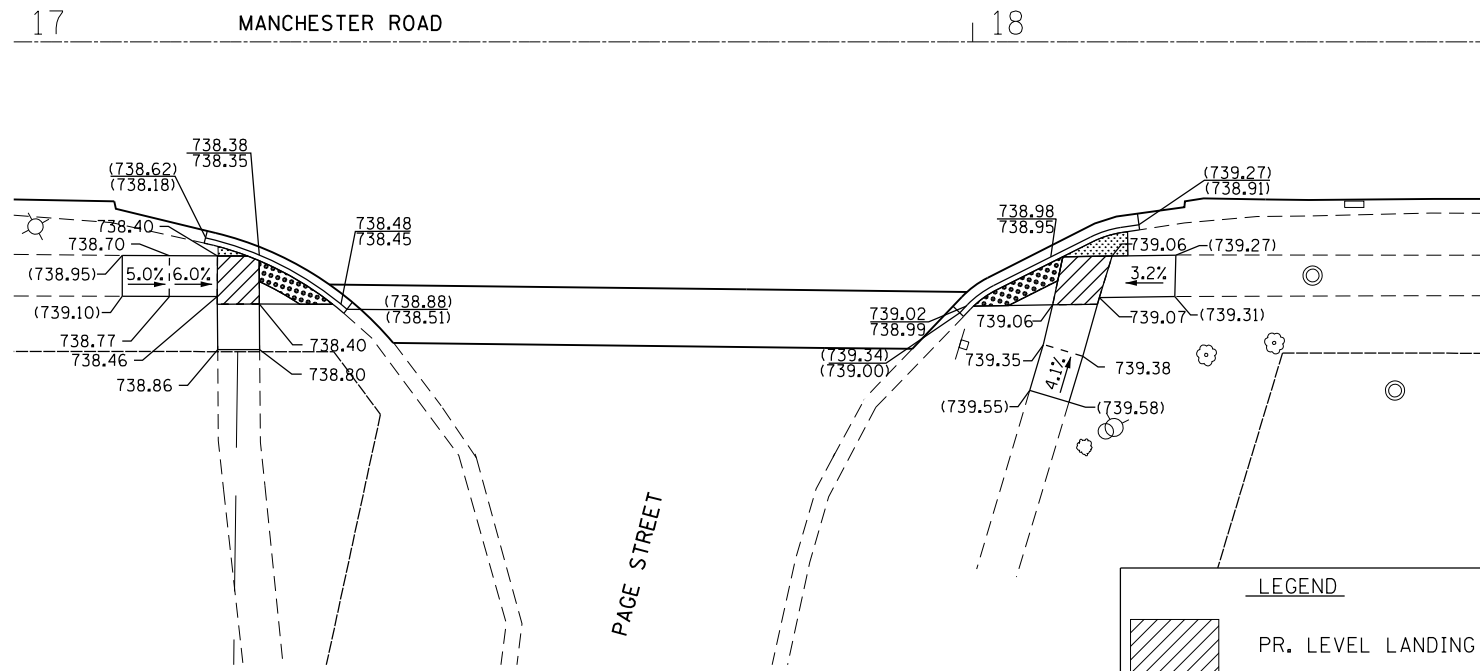

LEGEND

 PR. LEVEL LANDING PAD

 PR. DETECTABLE WARINGS

NOTE:

1. ALL SIDEWALK CROSS SLOPES SHALL BE 2.0% OR LESS

HORIZONTAL SCALE IN FEET

0 5 10 20



USER NAME = maciej	DESIGNED -	REVISED -
PLOT SCALE = 20.0000' / in.	DRAWN -	REVISED -
PLOT DATE = 12/19/2019	CHECKED -	REVISED -
	DATE -	REVISED -

F.A.U. RE.	SECTION	COUNTY	TOTAL SHEETS	SHEET NO.
3549	19-00121-00-RS	DuPAGE	35	20
CONTRACT:			61G23	
ILLINOIS FED. AID PROJECT				

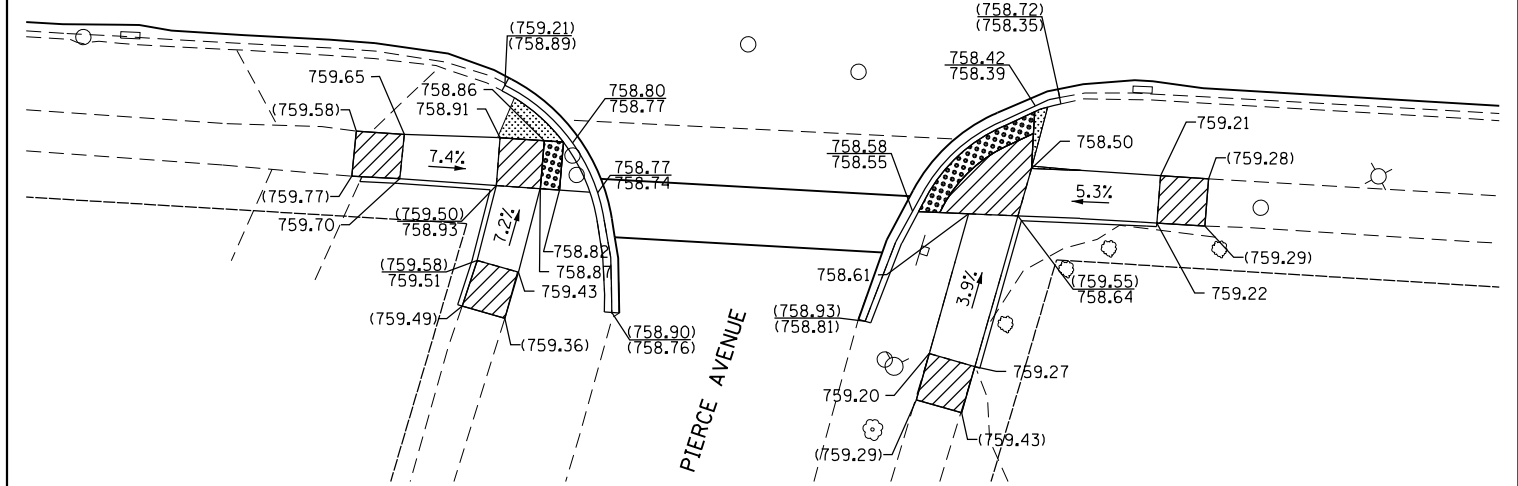
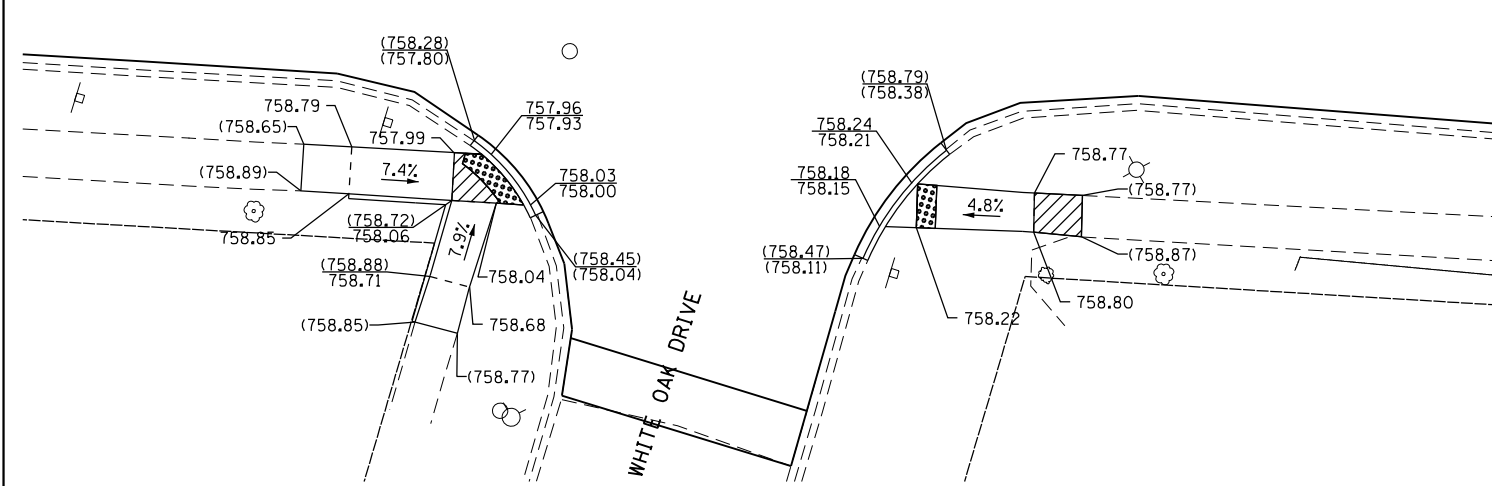
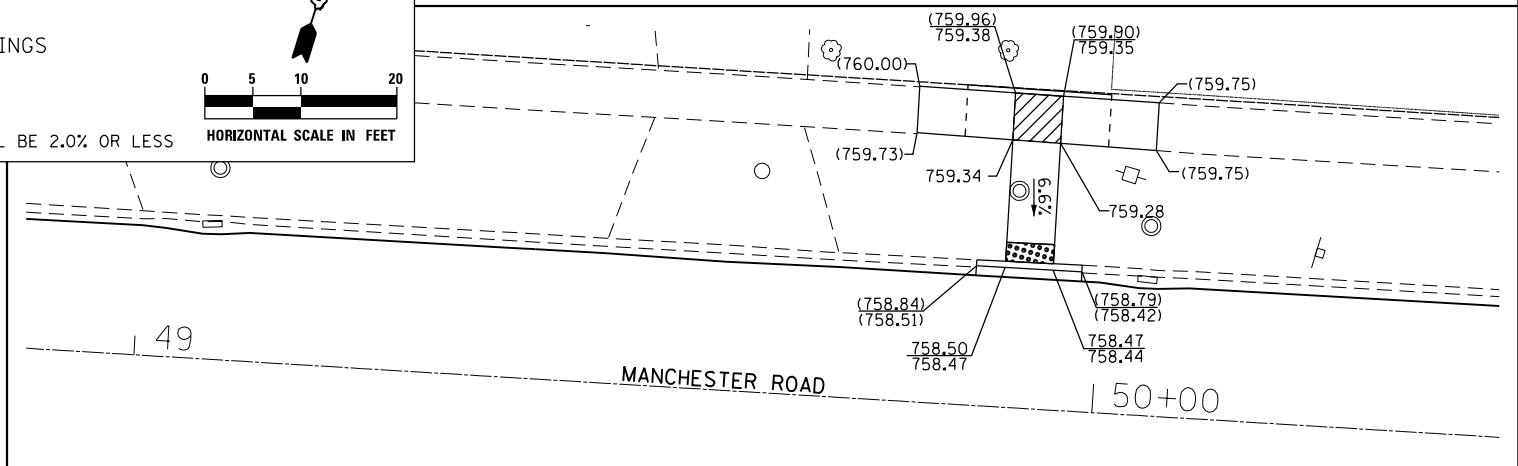
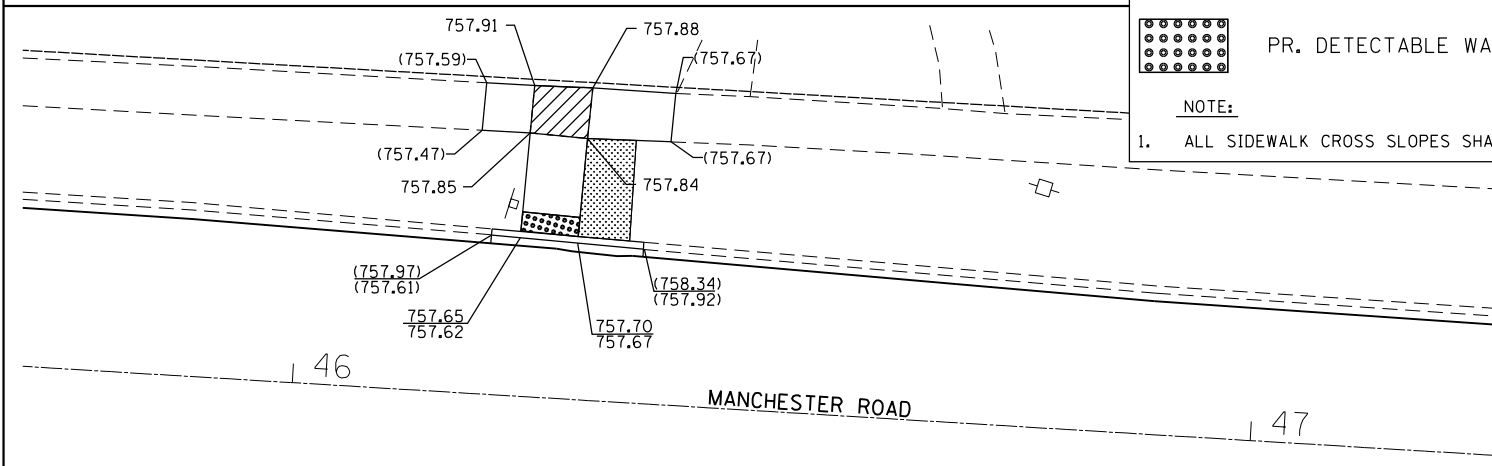
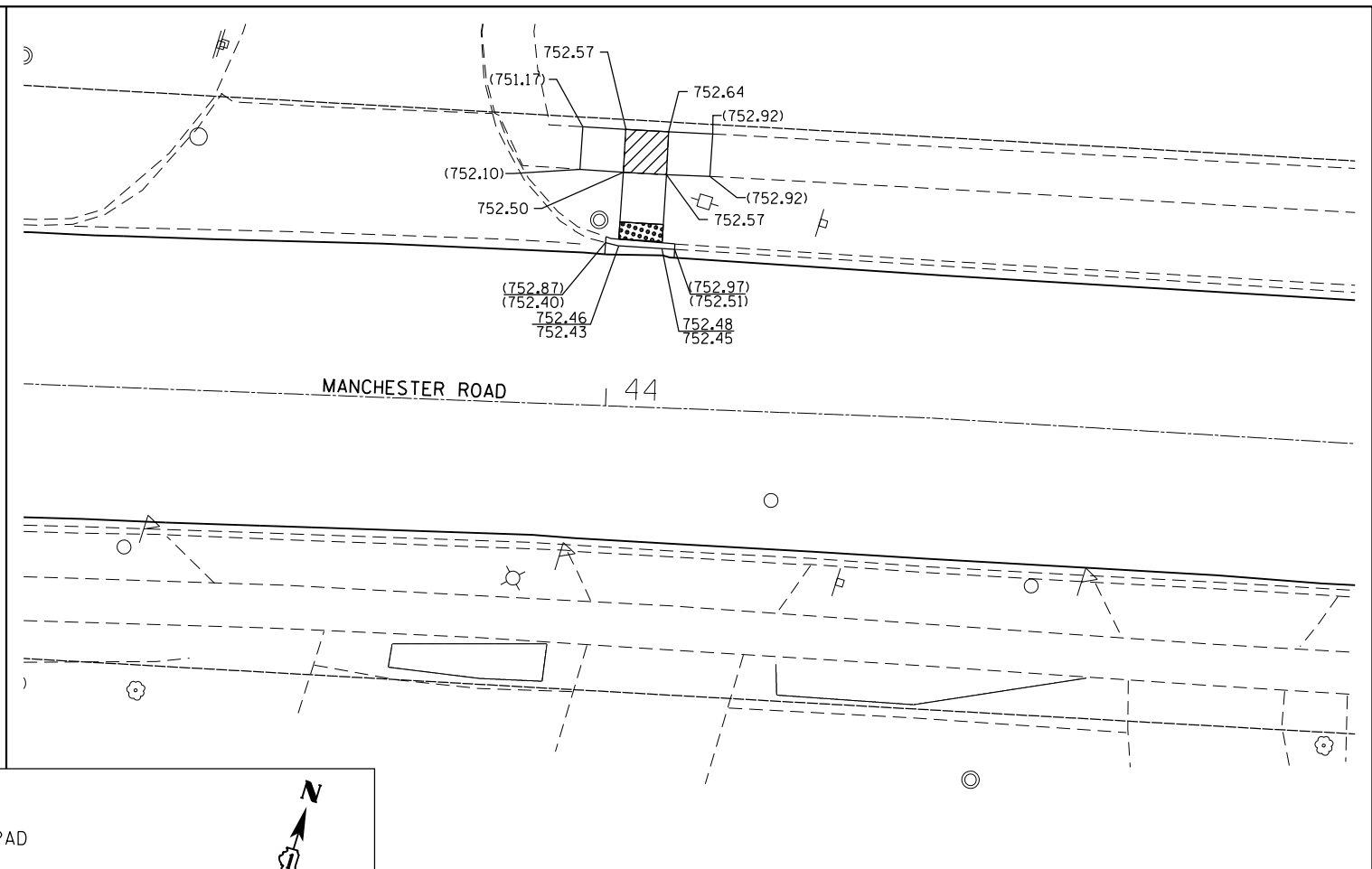
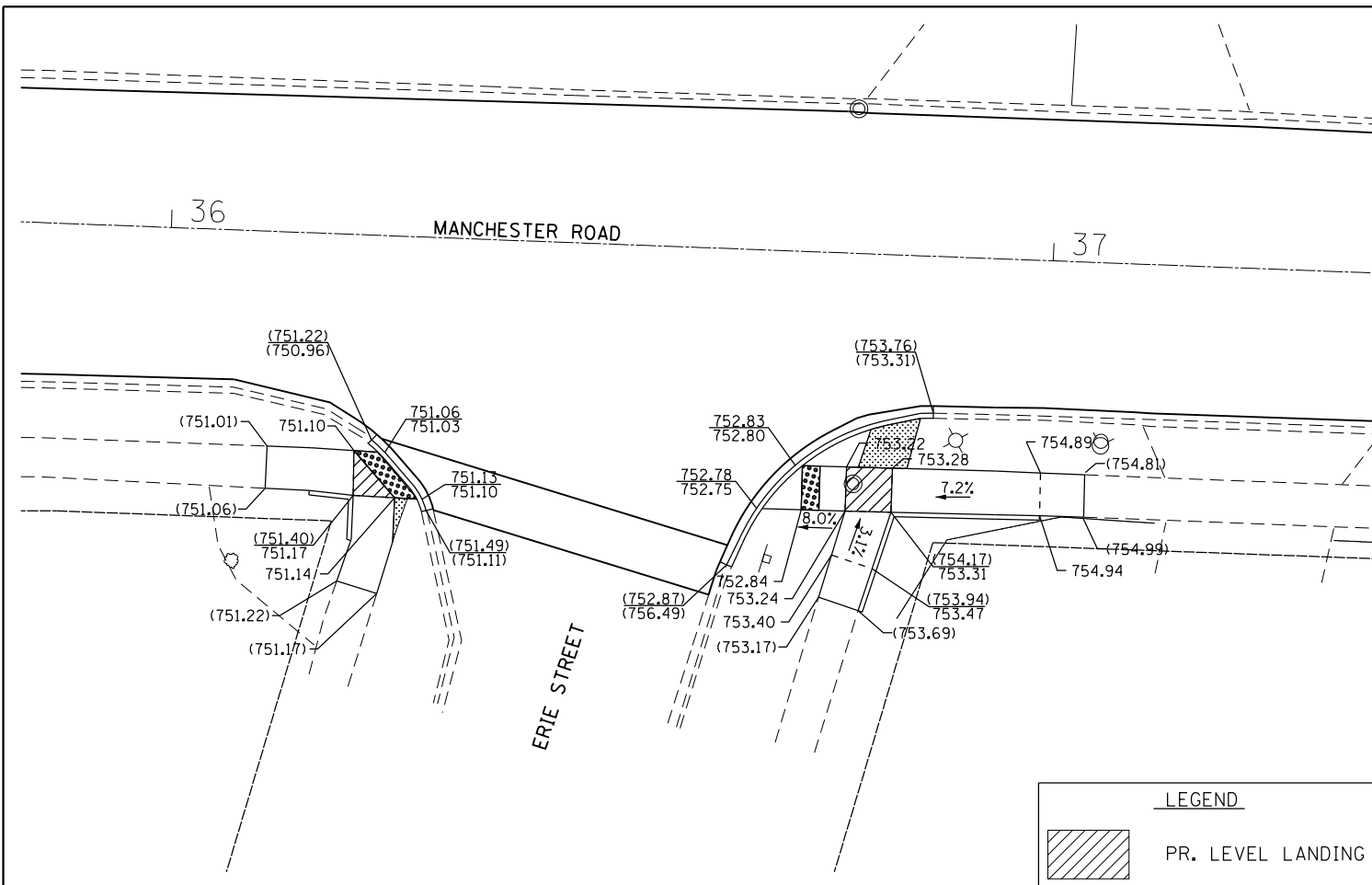

LEGEND

PR. LEVEL LANDING PAD

PR. DETECTABLE WARINGS

NOTE:

1. ALL SIDEWALK CROSS SLOPES SHALL BE 2.0% OR LESS

N

HORIZONTAL SCALE IN FEET

thomas engineering group, llc
 762 shoreline drive
 suite 200
 aurora, illinois 60504
 phone: 855-533-1700

USER NAME = maciej.k	DESIGNED -	REVISED -
PLOT SCALE = 20.0000' / in.	DRAWN -	REVISED -
PLOT DATE = 12/19/2019	CHECKED -	REVISED -
	DATE -	REVISED -

**STATE OF ILLINOIS
 DEPARTMENT OF TRANSPORTATION**

SIDEWALK /ADA PLANS

SCALE:	SHEET	OF	SHEETS	STA.	TO	STA.
--------	-------	----	--------	------	----	------

F.A.U. R.E.	SECTION	COUNTY	TOTAL SHEETS	SHEET NO.
3549	19-00121-00-R5	DuPAGE	35	21
CONTRACT:			61G23	
ILLINOIS FED. AID PROJECT				

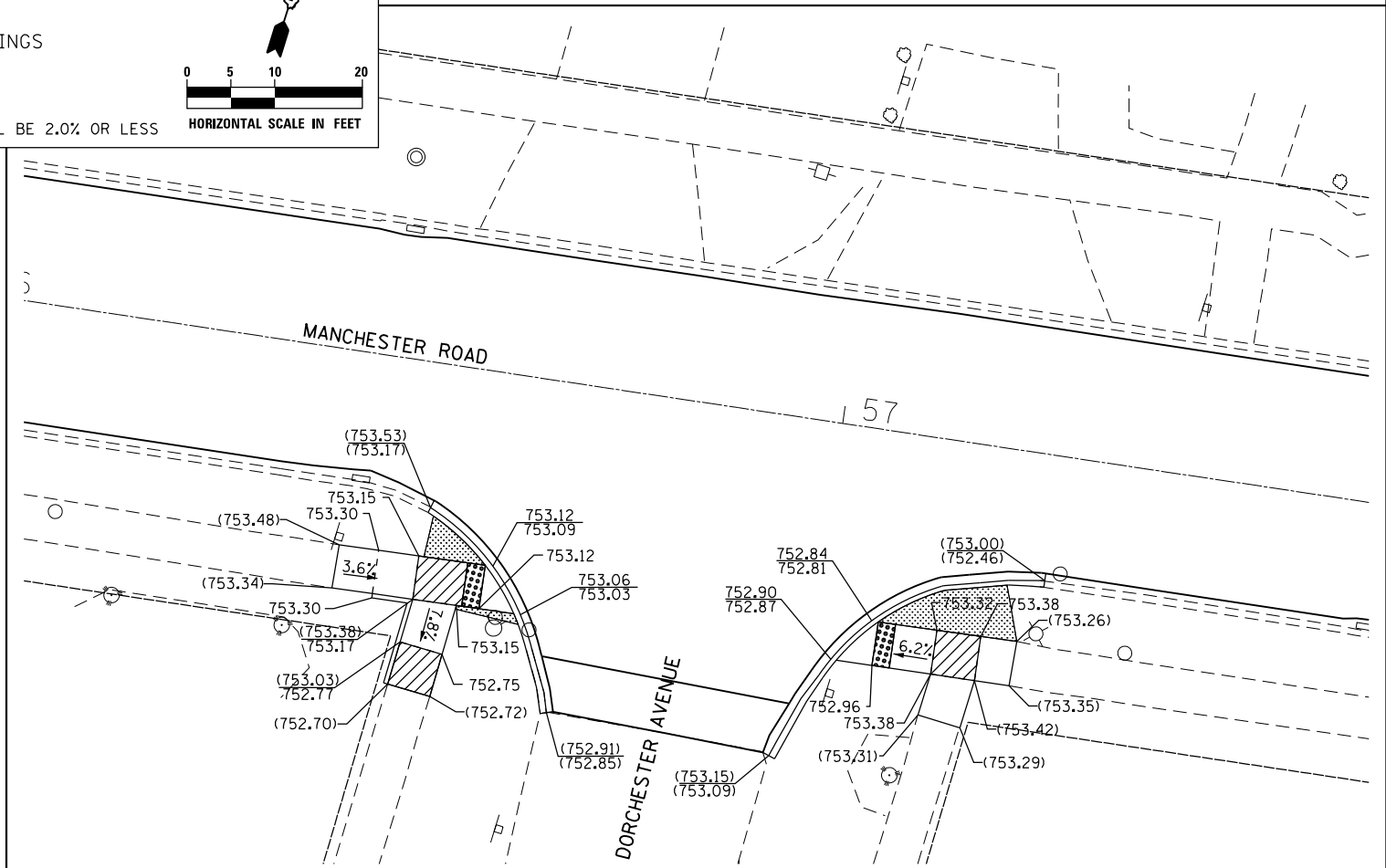
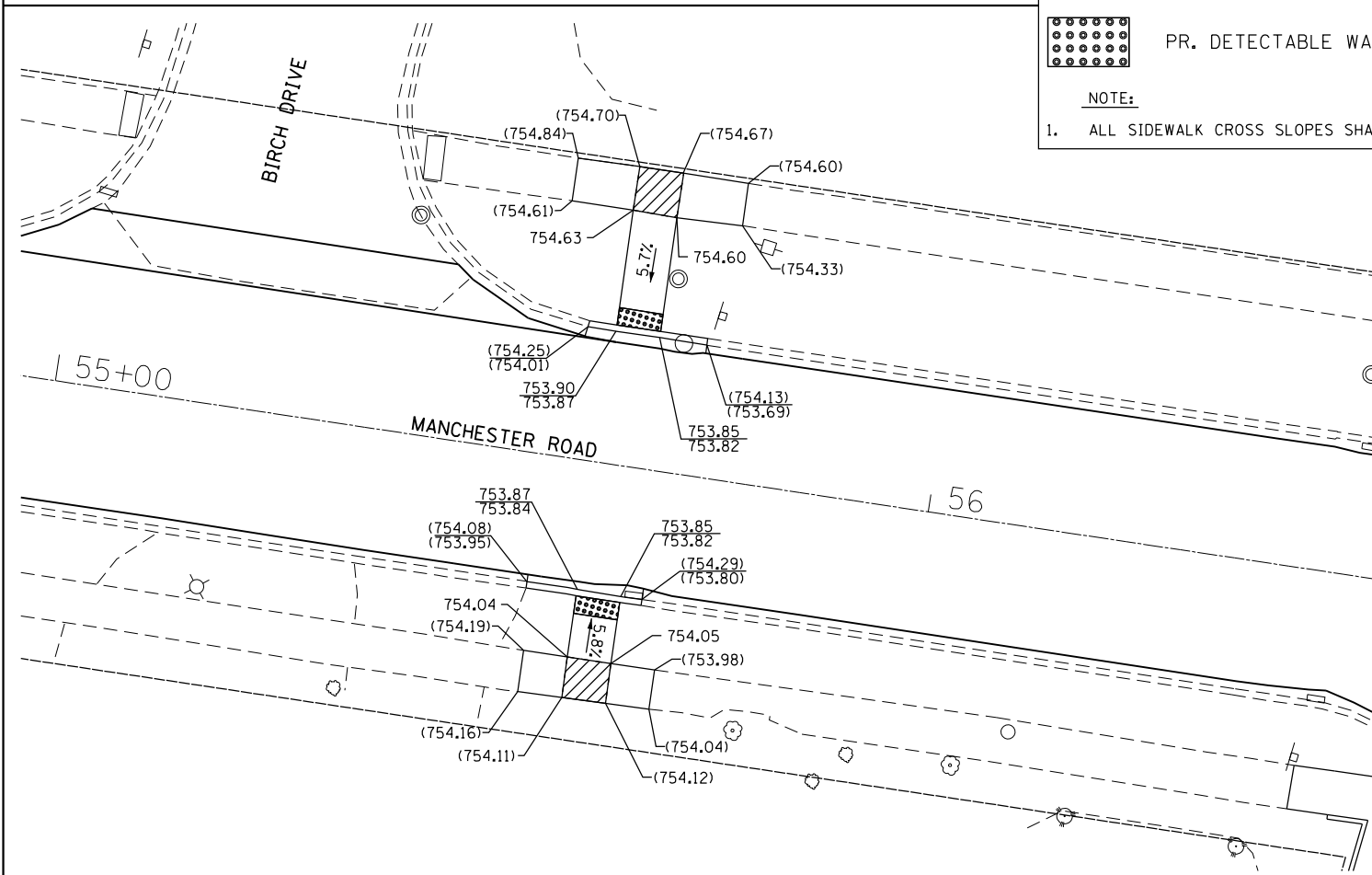
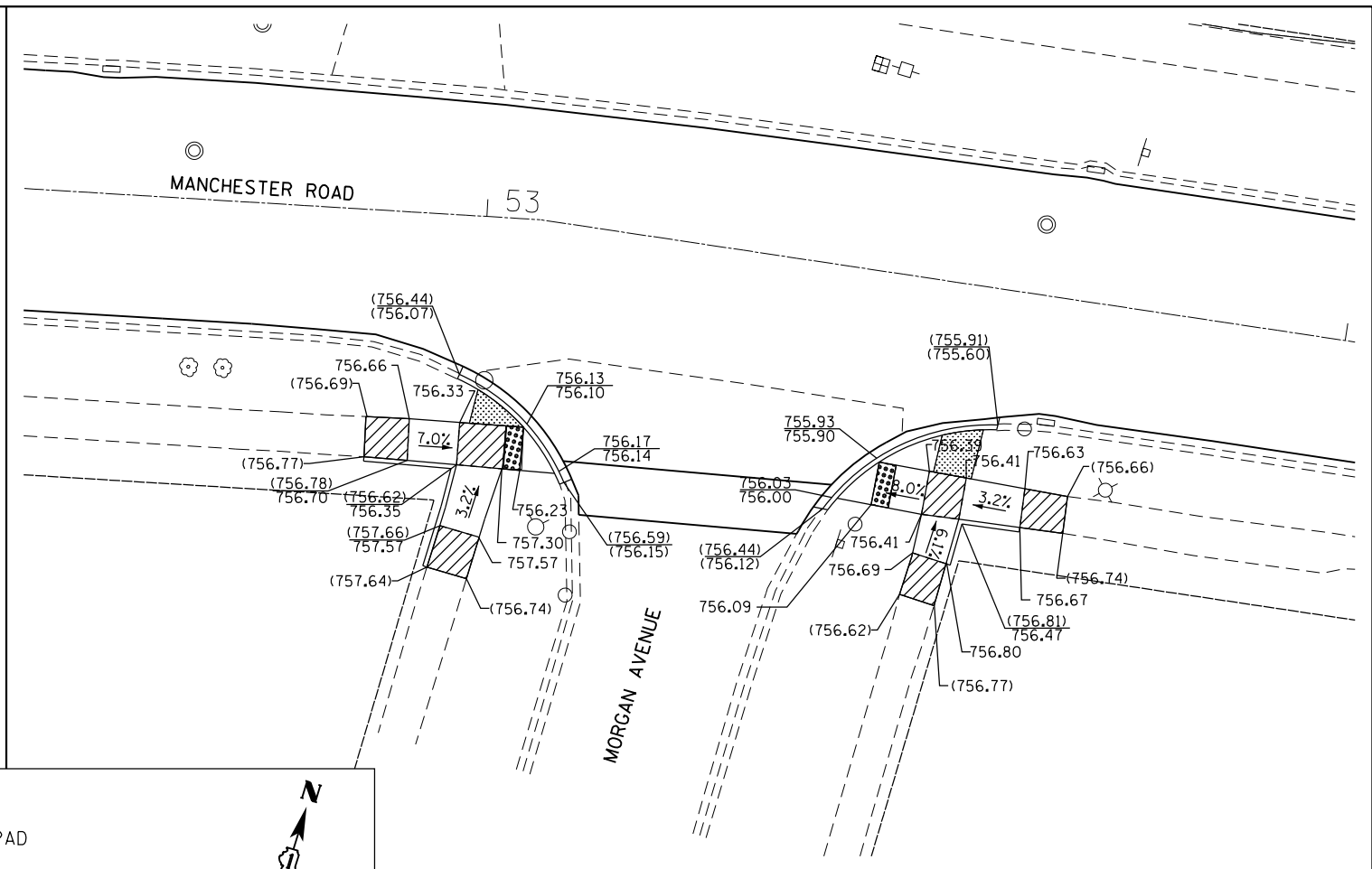
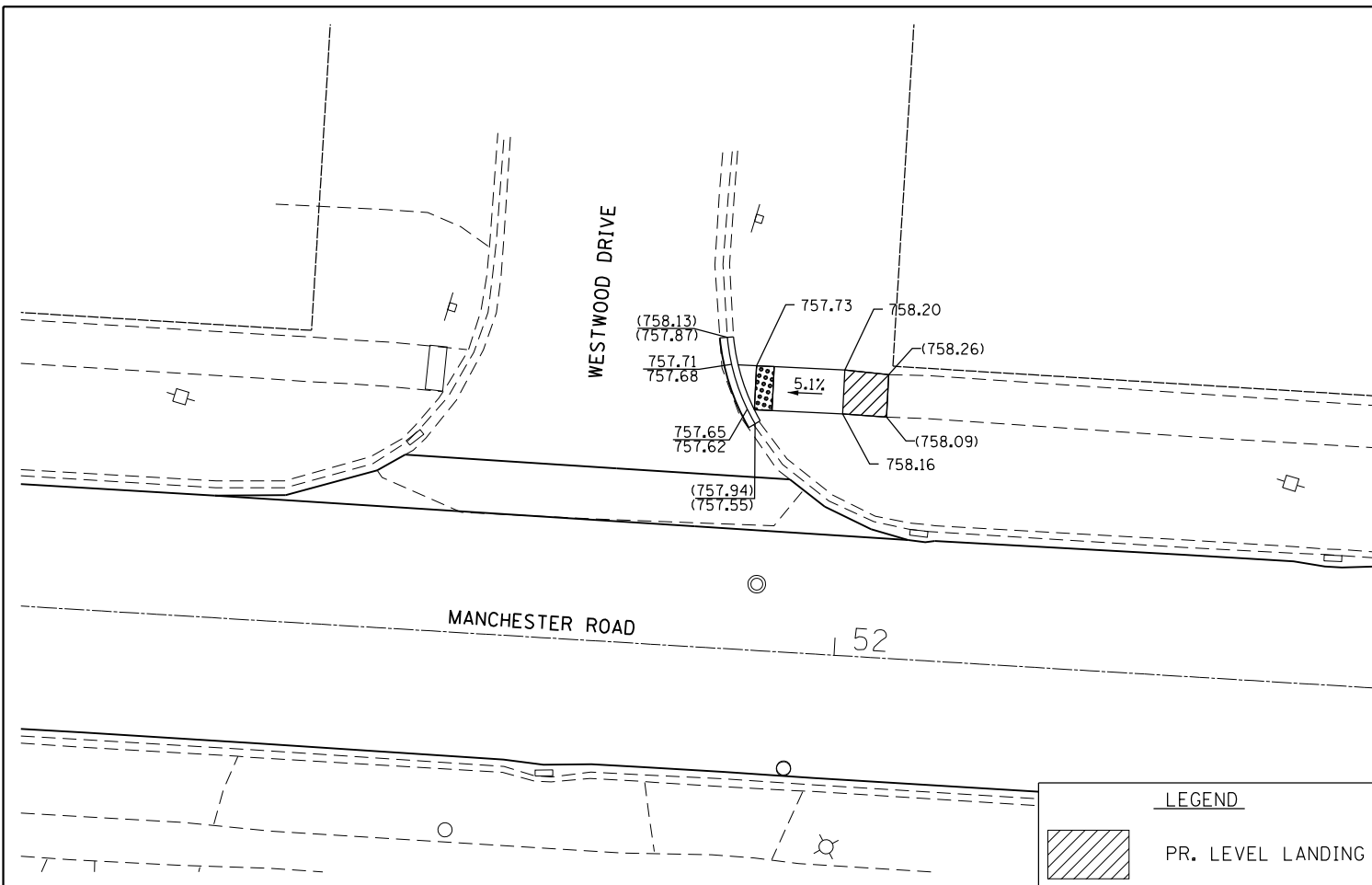

LEGEND

 PR. LEVEL LANDING PAD

 PR. DETECTABLE WARINGS

NOTE:

1. ALL SIDEWALK CROSS SLOPES SHALL BE 2.0% OR LESS

HORIZONTAL SCALE IN FEET

0 5 10 20



thomas thomas engineering group, llc
762 shoreline drive
suite 200
aurora, illinois 60504
phone: 855-533-1700

USER NAME = maciej.k	DESIGNED -	REVISD -
PLOT SCALE = 20.0000' / in.	DRAWN -	REVISD -
PLOT DATE = 12/19/2019	CHECKED -	REVISD -
	DATE -	REVISD -

**STATE OF ILLINOIS
DEPARTMENT OF TRANSPORTATION**

SIDEWALK /ADA PLANS

SCALE:	SHEET	OF	SHEETS	STA.	TO	STA.
--------	-------	----	--------	------	----	------

F.A.U. R.E.	SECTION	COUNTY	TOTAL SHEETS	SHEET NO.
3549	19-00121-00-R5	DUPAGE	35	22
CONTRACT:			61G23	
ILLINOIS FED. AID PROJECT				

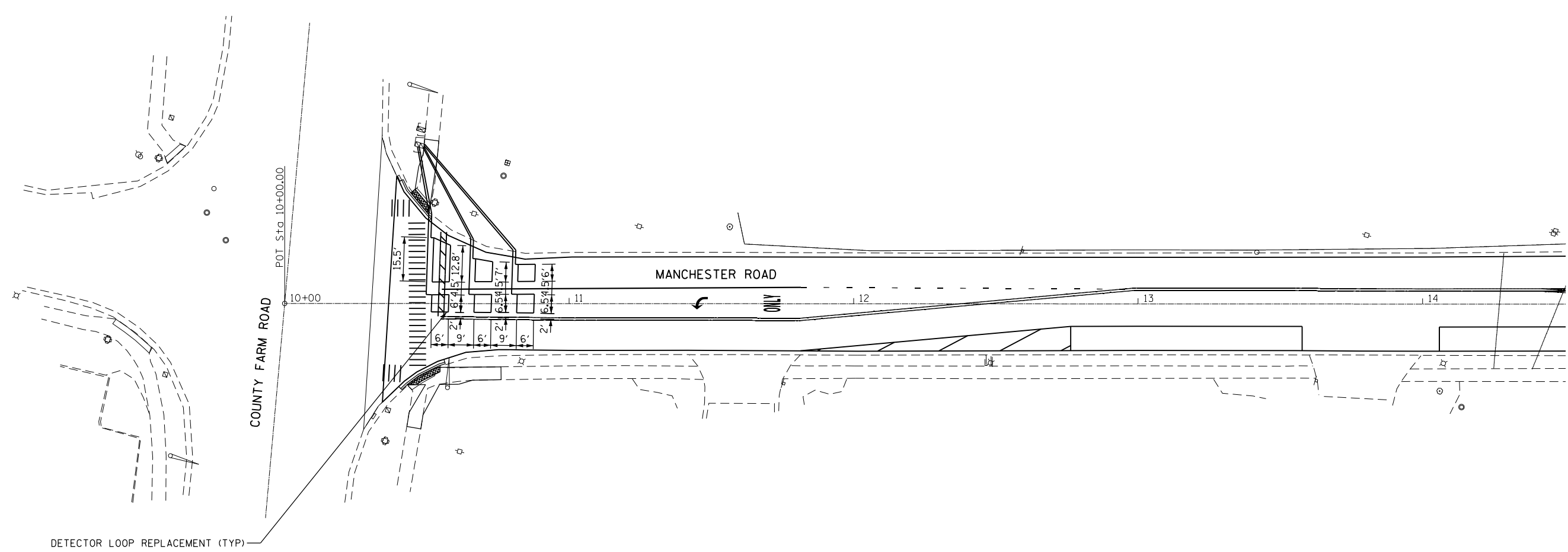

NOTES:

1. PROPOSED DETECTOR LOOPS ARE SHOWN TO MATCH EXISTING CONDITIONS. CONTRACTOR SHALL VERIFY ALL DETECTOR LOOP LOCATIONS AND CONFIRM ROUTING BACK TO HANHOLE.
2. ANY PROPOSED CHANGES TO THE DETECTOR LOOPS SHALL BE APPROVED BY THE ENGINEER PRIOR TO PLACEMENT.
3. EXISTING LOOPS BEYOND RESURFACING LIMITS SHALL REMAIN IN PLACE FOR USE IN THE PROPOSED CONDITION. CONTRACTOR SHALL TAKE CARE TO AVOID DAMAGING EXISTING LOOPS OUTSIDE OF RESURFACED AREAS.

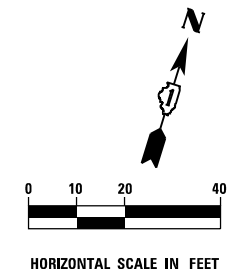

DRIVE APPROACH & SIDEWALK

GENERAL STANDARDS

- All Portland Cement Concrete shall conform to Illinois Department of Transportation Class SI mix.
- Where new concrete work meets or abuts any existing concrete structures, the existing concrete shall be saw cut to a straight and clean edge and expansion material placed between the new and existing work.
- Expansion material is also required between new curb and new concrete approaches; new sidewalk and new concrete driveways; and new curb and new sidewalk.
- A culvert will be required where the street does not have curb and gutter.
- Replacement of barrier curb and gutter with depressed curb and gutter to be with a single pour. Gutter shall be a minimum of 8" thick.
- Wire mesh is not required.
- Pea gravel is not allowed as fill or base material.
- All curb replacements shall be a minimum of 5' in length.

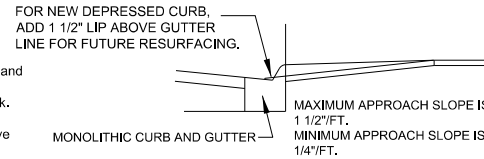

** See Note 6

- COVER OVER CULVERT SHALL BE A MINIMUM OF 5" OR 1/2 CULVERT DIAMETER, OR WHICHEVER IS LARGER.
- MINIMUM CULVERT SIZE: 10" DIAMETER.

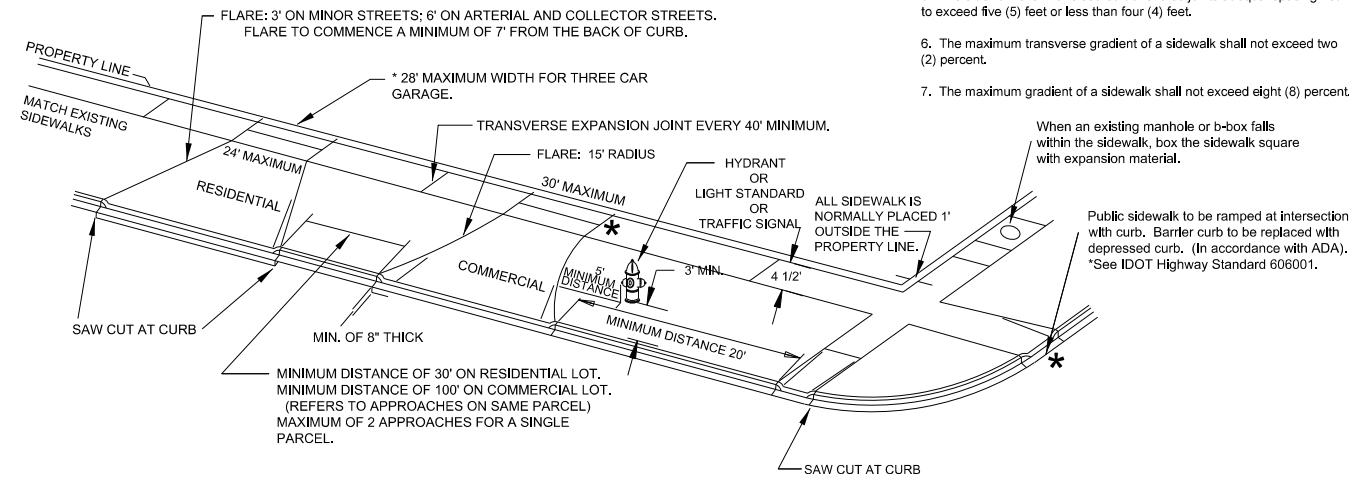

RESIDENTIAL APPROACH

- Shall be 5" thick, Portland Cement Concrete, Class SI
- 1 1/2" Bituminous Concrete, on an 8" thick aggregate base
- Brick pavers shall be constructed in accordance with the manufacturer's specifications. Manufacturer's specifications must be submitted as part of the permit application.

COMMERCIAL APPROACH

- 6" thick, Portland Cement Concrete, Class SI (Bituminous is not permitted)

SIDEWALK

- 4" thick, Portland Cement Concrete on a compacted crushed aggregate or bank run gravel base.
- 5" thick through Residential Approaches
- 6" thick through Commercial Approaches
- Walk shall be no lower than the centerline of the street.
- The sidewalk shall have scored transverse joints at equal spacing not to exceed five (5) feet or less than four (4) feet.
- The maximum transverse gradient of a sidewalk shall not exceed two (2) percent.
- The maximum gradient of a sidewalk shall not exceed eight (8) percent.

TRANSITION CURB AT INLET OR C.B.

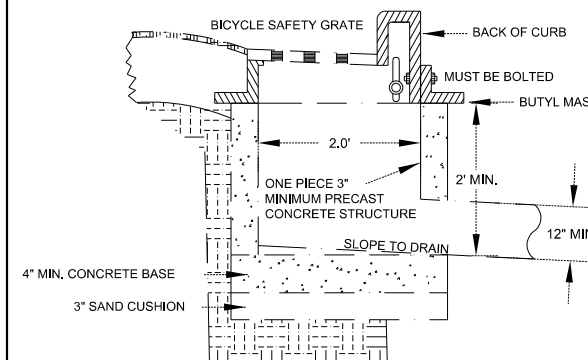

- A MAXIMUM ADJUSTMENT OF 8" USING 2 (TWO) RUBBER RINGS IS ALLOWED. A MINIMUM OF 1 (ONE) RUBBER RING SHOULD BE INSTALLED BETWEEN THE FRAME AND STRUCTURE
- BRICKS ARE NOT PERMITTED FOR ADJUSTMENTS.
- FOR ROLLED AND/OR BARRIER CURB USE NEENAH R-3010 OR EJIW 7045Z FRAME, 7040M1 GRATE AND 7050T1 CURB BACK OR US FOUNDRY 5132.
- ALL JOINTS BETWEEN BARREL SECTION, RISER, AND CASTING SHALL BE SEALED WITH FLEXIBLE BUTYL MASTIC MATERIAL 2-1/4" WIDE AND 3/8" THICK OR ENGINEER APPROVED SUBSTITUTE. MORTAR IS NOT ALLOWED.
- THE GRATE SHALL BE A BICYCLE SAFETY GRATE.
- REFERENCE: STANDARD SPECIFICATIONS FOR WATER AND SEWER MAIN CONSTRUCTION IN ILLINOIS, MAY 1996, SECTION 33.
- ANY SUBSTITUTIONS MUST BE APPROVED BY THE ENGINEER.
- 2' INSIDE DIAMETER TO BE USED AT END OF PIPE RUN ONLY. IN ALL INSTANCES WHERE 2 OR MORE PIPES ENTER OR EXIT C.B., 4' INSIDE DIAMETER STRUCTURE MUST BE USED.
- MINIMUM PIPE DIAMETER IS 12" ON 2' STRUCTURE.
- ANY NEW FRAME BACKS MUST HAVE STAMPED FISH SYMBOL PER NPDES REQUIREMENTS.

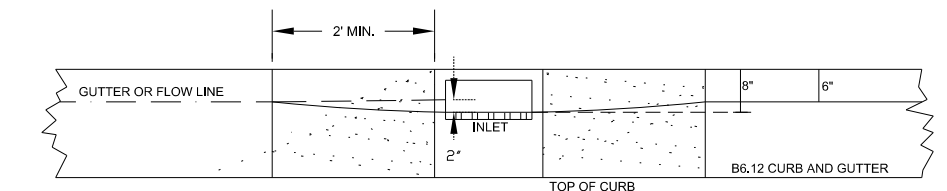
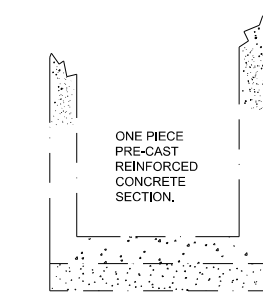

BARRIER CURB AND GUTTER TYPE B 6.12

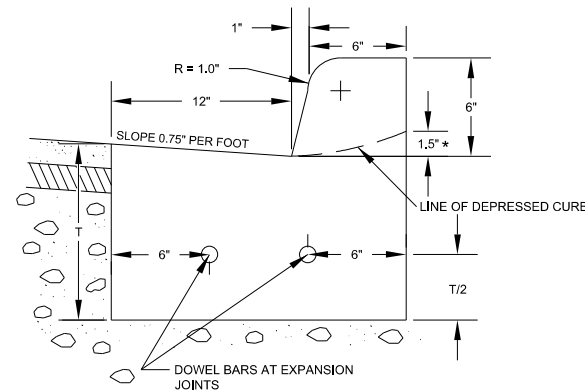

TYPE M 3.12

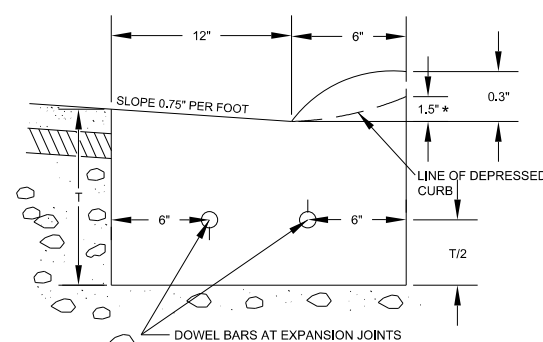

T = THICKNESS OF PAVEMENT
* = 1/2" AT ADA RAMP LOCATIONS

- NOTE:
- TWO NO.6 STEEL DOWEL BARS WITH CAPS TO BE USED AT ALL EXPANSION JOINTS 100 ft. INTERVALS.
 - CONSTRUCTION JOINTS AT 25 ft. INTERVALS.
 - THREE 3/8" RE-BARS AT ALL TRENCH CROSSINGS. BARS TO EXTEND TWO FEET BEYOND EDGE OF TRENCH AND HAVE A MINIMUM LENGTH OF 10 FT.
 - THE BASE COURSE WILL BE OF A DEPTH SUFFICIENT TO BRING THE CURB AND GUTTER TO THE PROPOSED GRADE.
 - THE BASE COURSE LOCATED UNDER THE CURB AND GUTTER WILL NOT BE MEASURED FOR PAYMENT, BUT SHALL BE INCLUDED IN THE UNIT PRICE BID FOR COMBINATION CONCRETE CURB AND GUTTER OF THE TYPE SPECIFIED.
 - THE HEIGHT OF DEPRESSED CURB ADJACENT TO ADA RAMP LOCATIONS SHALL BE 1/2'.
 - SEE STANDARD 606001-06.

USER NAME = maciej.k	DESIGNED -	REVISED
PLOT SCALE = 2.0000' / in.	DRAWN -	REVISED -
PLOT DATE = 12/19/2019	CHECKED -	REVISED -
	DATE -	REVISED -

F.A.U. RTE.	SECTION	COUNTY	TOTAL SHEETS	SHEET NO.
3549	19-00121-00-R5	DuPAGE	35	25
CONTRACT:			61G23	
ILLINOIS FED. AID PROJECT				

FRAMES AND LIDS ADJUSTMENT WITH MILLING

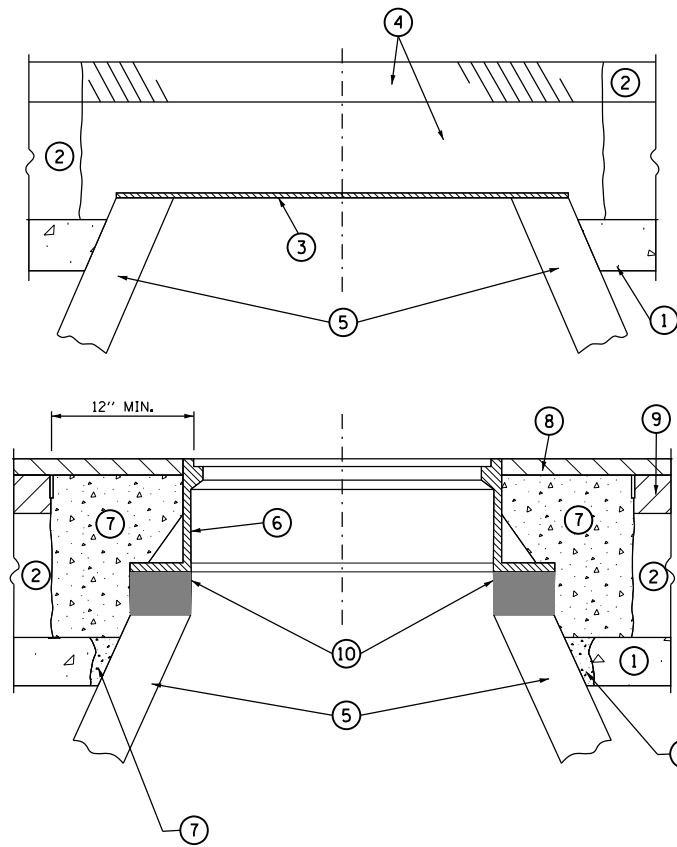

- ① SUB-BASE GRANULAR MATERIAL
- ② EXISTING PAVEMENT
- ③ 36" DIAMETER METAL PLATE
- ④ PROPOSED CRUSHED STONE AND HMA SURFACE MIX
- ⑤ EXISTING STRUCTURE
- ⑥ FRAME AND LID (SEE NOTES)
- ⑦ CLASS PP-1* CONCRETE
- ⑧ PROPOSED HMA SURFACE COURSE
- ⑨ PROPOSED HMA BINDER COURSE
- ⑩ PROPOSED RUBBER ADJUSTMENT RISER RING

STAGE 1 (BEFORE PAVEMENT MILLING)

- A) REMOVE A MINIMUM OF 12" OF THE PAVEMENT FROM AROUND THE STRUCTURE.
- B) REMOVE THE EXISTING FRAME AND LID FROM THE STRUCTURE.
- C) COVER THE STRUCTURE OPENING WITH A 36" DIAMETER METAL PLATE.
- D) BACKFILL WITH CRUSHED STONE AND A MINIMUM 1 1/2" THICK HMA SURFACE MIX APPROVED BY THE ENGINEER.

STAGE 2 (AFTER PAVEMENT MILLING)

- A) REMOVE THE HMA SURFACE MIX AND CRUSHED STONE.
- B) INSTALL THE FRAME AND LID; ADJUST THE FRAME TO ITS FINAL SURFACE ELEVATION. A MINIMUM OF ONE RUBBER ADJUSTMENT RISER RING SHALL BE USED.
- C) THE SURROUNDING SPACE SHALL BE FILLED WITH CLASS PP-1* CONCRETE TO THE ELEVATION OF THE SURFACE OF THE EXISTING BASE COURSE OR THE BINDER COURSE.

• UNLESS OTHERWISE SPECIFIED IN THE PLANS.

THE PROCEDURE EXPLAINED ABOVE SHALL CONFORM TO THE APPLICABLE PORTIONS OF SECTIONS 353, 406, 602, AND 603 OF THE STANDARD SPECIFICATIONS EXCEPT THAT "THE CONTRACTOR SHALL ADJUST THE STRUCTURES TO THE FINISHED PAVEMENT ELEVATION NO MORE THAN 5 CALENDAR DAYS PRIOR TO PLACEMENT OF THE FINAL LIFT OF SURFACE UNLESS APPROVED BY THE ENGINEER."

LOCATION OF STRUCTURES:

THE CONTRACTOR WILL BE REQUIRED TO KEEP A RECORD OF THE LOCATIONS OF THE BURIED STRUCTURES ACCORDING TO THE STATION AND DISTANCE LEFT OR RIGHT OF THE CENTERLINE OF PAVEMENT. UPON COMPLETION OF THE WORK, THE CONTRACTOR WILL DELIVER THE RECORD TO THE ENGINEER.

BASIS OF PAYMENT:

REMOVING FRAMES AND LIDS ON DRAINAGE AND UTILITY STRUCTURES IN THE PAVEMENT PRIOR TO MILLING, AND ADJUSTING TO FINAL GRADE PRIOR TO PLACING THE SURFACE COURSE, WILL BE PAID FOR AT THE CONTRACT UNIT PRICE EACH FOR AS "STRUCTURE TO BE ADJUSTED," OF THE TYPE OF STRUCTURE SPECIFIED.

THIS WORK WILL NOT BE PAID FOR WHEN DRAINAGE AND UTILITY STRUCTURES ARE SPECIFIED FOR PAYMENT AS STRUCTURE RECONSTRUCTION.

NEW FRAMES AND LIDS, WHEN SPECIFIED, WILL BE PAID FOR SEPARATELY.

NOTES:

EXISTING BROKEN FRAMES AND LIDS SHALL BE REMOVED AND DISPOSED OF BY THE CONTRACTOR AND SHALL BE REPLACED AS DIRECTED BY THE ENGINEER. REPLACEMENT FRAMES AND LIDS WILL BE PAID FOR IN ACCORDANCE WITH ARTICLE 109.04 OF THE STANDARD SPECIFICATIONS UNLESS A SEPARATE PAY ITEM HAS BEEN PROVIDED.

IF THE EXISTING LIDS ARE OPEN, THE FRAME WILL BE ADJUSTED TO THE ELEVATION OF THE MILLED PAVEMENT SURFACE PRIOR TO THE MILLING OPERATION. THE FRAME WILL NOT BE REMOVED AND COVERED BY THE METAL PLATE.

THE METAL PLATE USED TO COVER THE STRUCTURE SHALL REMAIN THE PROPERTY OF THE CONTRACTOR.

WHEN STRUCTURES ARE TO BE ADJUSTED OR RECONSTRUCTED, THE LOWERING AND RAISING OF THE FRAMES AND LIDS WILL NOT BE PAID FOR SEPARATELY BUT WILL BE INCLUDED IN THE COST OF THE CORRESPONDING PAY ITEM.

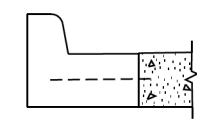
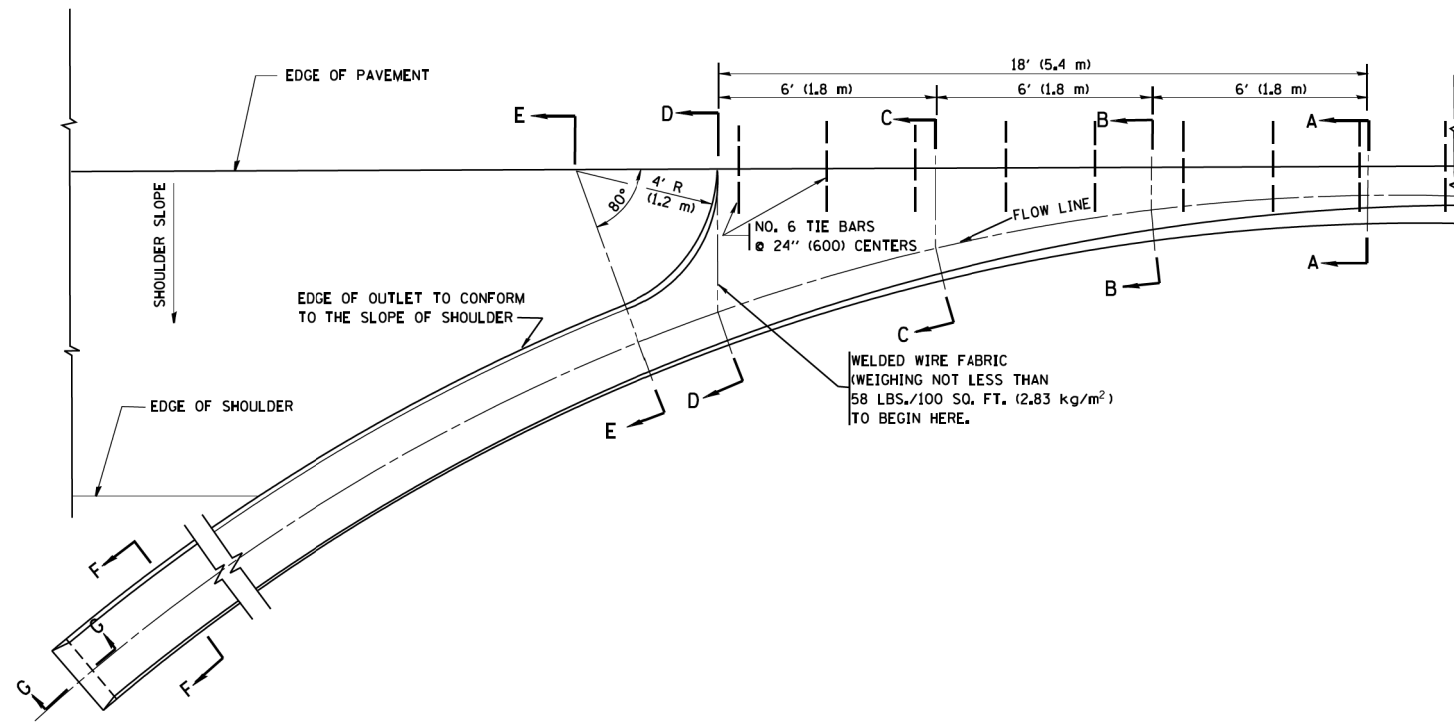

A-A *

* DIMENSIONS OF THE CURB & GUTTER AT SECTION A-A ARE SHOWN ON STATE STANDARD 606001. FOR DETAILS OF OUTLET FOR CONCRETE CURB & GUTTER, TYPE B-6.24 (B-15.60) SEE STATE STANDARD 606006.

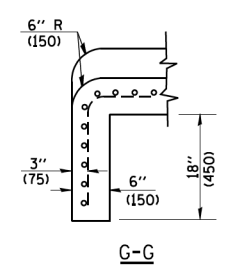
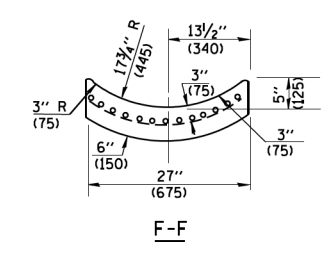
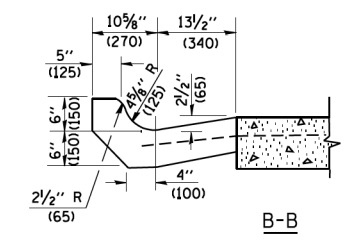
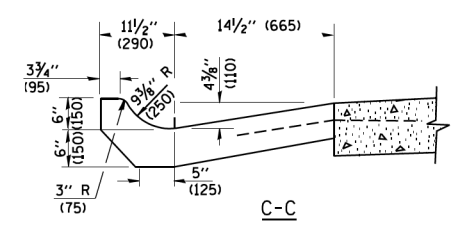
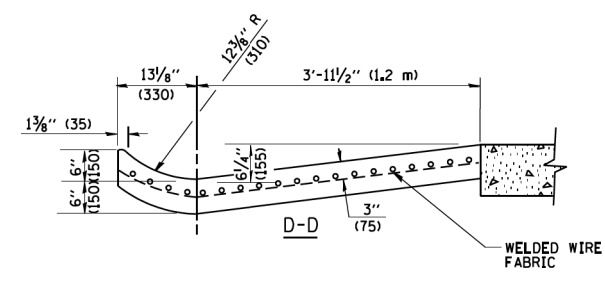
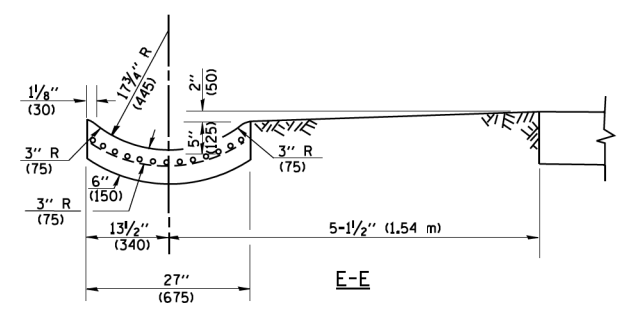

GENERAL NOTES

GUTTER OUTLET SHALL BE TIED TO THE PAVEMENT IN ACCORDANCE WITH DETAILS FOR LONGITUDINAL CONSTRUCTION JOINT SHOWN ON STANDARD 420001.

TIE BARS SHALL BE NO. 20 (NO.6) AT 24\" (600) CENTERS UNLESS OTHERWISE SHOWN.

IF THE AVERAGE GRADE OF PAVEMENT FOR THE DISTANCE FROM SECTION A-A TO D-D EXCEEDS 2%, THIS DISTANCE SHALL BE INCREASED 6\" (1.8 m) FOR EACH 1% INCREASE IN GRADE.

QUANTITIES

FOR SECTION A-A TO E-E AND CURTAIN WALL =
 1.25 CU. YDS. (0.96 m³) CLASS SI CONCRETE (OUTLET) FOR 9\" (225) PAV'T.
 1.27 CU. YDS. (0.96 m³) CLASS SI CONCRETE (OUTLET) FOR 10\" (250) PAV'T.
 FOR SECTION F-F =
 0.045 CU. YDS. (0.03 m³) CLASS SI CONCRETE PER FT. (M).

ALL DIMENSIONS ARE IN INCHES (MILLIMETERS) UNLESS OTHERWISE SHOWN.

FILE NAME = W:\diststa\22x34\bd03.dgn	USER NAME = gegl1enobt	DESIGNED - M. DE YONG	REVISED - R. SHAH 09-09-94	STATE OF ILLINOIS DEPARTMENT OF TRANSPORTATION	OUTLET FOR CONCRETE CURB AND GUTTER			F.A.U. RTE. = 3549	SECTION = 19-00121-00-RS	COUNTY = DuPAGE	TOTAL SHEETS = 35	SHEET NO. = 27
	PLOT SCALE = 50.0000' / IN.	CHECKED -	REVISED - E. GOMEZ 12-21-00					SCALE: NONE	SHEET NO. 1 OF 1 SHEETS	STA. TO STA.	BD600-01 (BD-03)	
PLOT DATE = 1/4/2008	DATE = 08-04-86	REVISED -	REVISED -	FED. ROAD DIST. NO. 1 ILLINOIS FED. AID PROJECT								

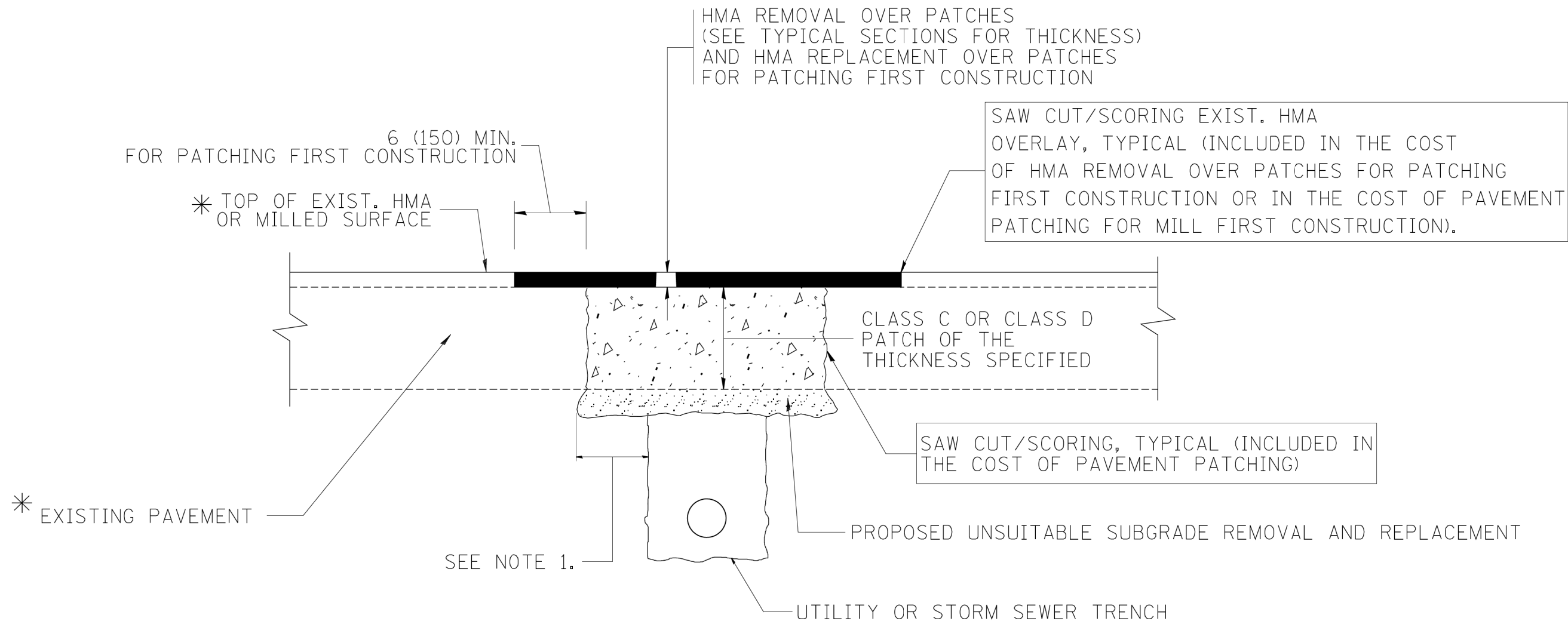

* SEE TYPICAL SECTIONS FOR THICKNESS AND MATERIALS

NOTES:

1. THE WIDTH OF THE FULL DEPTH PATCH OVER A TRENCH SHALL BE 12 (300) WIDER ON EACH SIDE OF THE TRENCH.
2. FOR METHOD OF MEASUREMENT AND BASIS OF PAYMENT, SEE RECURRING SPECIAL PROVISION "PATCHING WITH HOT-MIX ASPHALT OVERLAY REMOVAL".

SEQUENCE OF CONSTRUCTION (PATCHING FIRST)

1. REMOVE THE EXISTING HMA MATERIAL OVER THE AREA TO BE PATCHED.
2. REMOVE AND REPLACE WITH CLASS C OR D PATCH.
3. REPLACE HMA MATERIAL OVER THE AREA TO BE PATCHED.

SEQUENCE OF CONSTRUCTION (MILLING FIRST)

1. MILL HMA FIRST IF THERE IS AT LEAST 4 1/2 INCHES OR MORE OF HMA MATERIAL ON TOP OF THE EXISTING PAVEMENT OR IF THE PAVEMENT IS FULL DEPTH HMA. A MINIMUM OF 2 INCHES OF HMA MATERIAL SHALL BE IN PLACE AFTER MILLING.
2. REMOVE AND REPLACE WITH FULL DEPTH CLASS D PATCHES TO TOP OF MILLED SURFACE.

ALL DIMENSIONS ARE IN INCHES (MILLIMETERS) UNLESS OTHERWISE SHOWN.

FILE NAME = c:\projects\diststd22x34\bd22.dgn	USER NAME = bauerdl	DESIGNED - R. SHAH	REVISED - A. ABBAS 04-27-98	STATE OF ILLINOIS DEPARTMENT OF TRANSPORTATION	PAVEMENT PATCHING FOR HMA SURFACED PAVEMENT			F.A.U. RTE. 3549	SECTION 19-00121-00-RS	COUNTY DuPAGE	TOTAL SHEETS 35	SHEET NO. 28
	PLOT SCALE = 50.000' / IN.	CHECKED -	REVISED - R. BORO 01-01-07		SCALE: NONE	SHEET NO. 1 OF 1 SHEETS	STA.	TO STA.	BD400-04 (BD-22)		CONTRACT NO. 61G23	
	PLOT DATE = 10/27/2008	DATE - 10-25-94	REVISED - K. ENG 10-27-08		FED. ROAD DIST. NO. 1 ILLINOIS FED. AID PROJECT							

VARIABLE - TO MEET EXISTING DIMENSIONS AND FIELD CONDITIONS (SEE NOTE ②)

PROP. CONC. CURB OR CURB AND GUTTER REPLACEMENT IN ACCORDANCE WITH STATE STANDARD 606001. (SEE NOTE ②)

SAW CUT FULL DEPTH - INCLUDED IN THE COST OF SIDEWALK, DRIVEWAY OR MEDIAN SURFACE REMOVAL PAY ITEM.

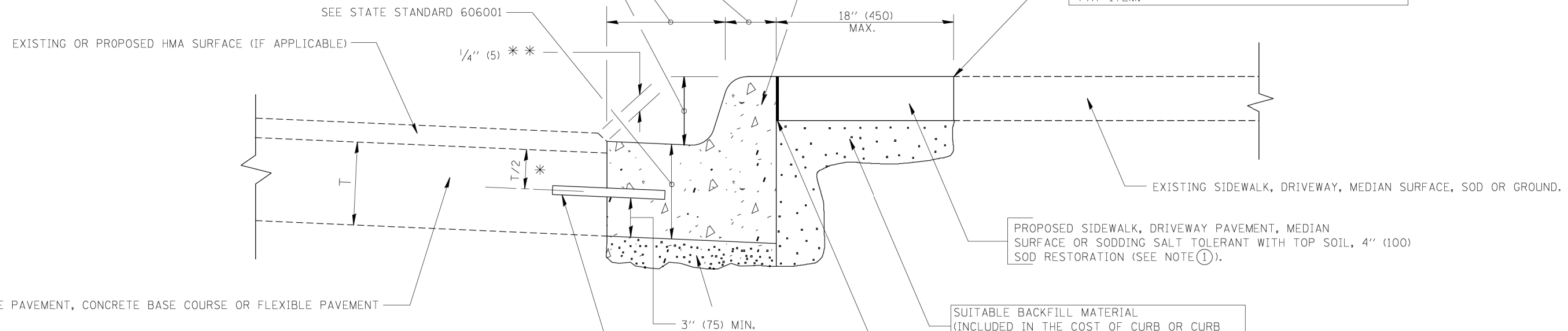

PROPOSED SIDEWALK, DRIVEWAY PAVEMENT, MEDIAN SURFACE OR SODDING SALT TOLERANT WITH TOP SOIL, 4" (100) SOD RESTORATION (SEE NOTE ①).

SUITABLE BACKFILL MATERIAL (INCLUDED IN THE COST OF CURB OR CURB AND GUTTER REMOVAL AND REPLACEMENT)

PROPOSED 3/4" (20) PREFORMED EXPANSION JOINT AT CONCRETE SIDEWALKS, DRIVEWAYS, AND MEDIANS. (INCLUDED IN THE COST OF CURB OR CURB AND GUTTER REMOVAL AND REPLACEMENT.)

UNSUITABLE SUB-BASE MATERIAL TO BE REMOVED, IF DIRECTED BY THE ENGINEER, SHALL BE REPLACED WITH EITHER SUB-BASE GRANULAR MATERIAL, TYPE B OR ADDITIONAL THICKNESS OF CONCRETE.

REMOVAL AND REPLACEMENT 4" (100) OR LESS IS INCLUDED IN THE COST OF CURB OR CURB AND GUTTER REMOVAL AND REPLACEMENT.

REMOVAL AND REPLACEMENT IN EXCESS OF 4" (100) WILL BE PAID FOR IN ACCORDANCE WITH ARTICLE 109.04 OF THE STANDARD SPECIFICATIONS.

PROPOSED #6 (20) EPOXY COATED TIE BARS 24" (600) LONG AT 24" (600) CENTERS WILL NOT BE PAID FOR SEPARATELY. DELETE EPOXY COATED TIE BARS IF EXISTING TIE BARS ARE USABLE AS DETERMINED BY THE ENGINEER. (SEE NOTE ③).

BASIS OF PAYMENT:
THIS WORK WILL BE PAID FOR AT THE CONTRACT UNIT PRICE PER FOOT (METER) FOR "CURB REMOVAL AND REPLACEMENT" OR "COMBINATION CONCRETE CURB AND GUTTER REMOVAL AND REPLACEMENT".

* 3" (75) MINIMUM FROM TOP AND BOTTOM OF THE CONCRETE PAVEMENT OR BASE COURSE.

** IF THE FINAL SURFACE OF THE PAVEMENT IS CONCRETE, THE GUTTER IS TO BE FLUSH WITH THE PAVEMENT.

NOTE: ① SIDEWALK, DRIVEWAY PAVEMENT OR MEDIAN SURFACE SHALL BE SIMILAR TO THE MATERIAL BEING REMOVED AND WILL BE PAID FOR SEPARATELY. SODDING, SALT TOLERANT AND TOP SOIL, FURNISH AND PLACE 4" WILL BE PAID FOR SEPARATELY,

② FERTILIZER FOR THE PLACEMENT OF THE SOD IS NOT REQUIRED

③ CURB OR CURB AND GUTTER REPLACEMENT SHALL MATCH THE SHAPE OF THE EXISTING CURB OR CURB AND GUTTER UNLESS OTHERWISE SPECIFIED.

④ FOR CURB OR CURB AND GUTTER REMOVAL AND REPLACEMENT ADJACENT TO FLEXIBLE PAVEMENT DELETE EPOXY COATED TIE BARS.

⑤ LONGITUDINAL BARS, IF ENCOUNTERED IN THE EXISTING CURB OR CURB AND GUTTER, ARE NOT TO BE REPLACED. CUTTING AND REMOVING LONGITUDINAL BARS SHALL BE INCLUDED IN THE COST OF CURB OR CURB AND GUTTER REMOVAL AND REPLACEMENT.

⑥ THE COST OF HMA SURFACE REMOVAL IN THE EXISTING GUTTER FLAG SHALL BE INCLUDED IN THE COST OF THE CURB AND GUTTER REMOVAL AND REPLACEMENT.

⑦ THE REMOVAL AND REPLACEMENT OF THE EXISTING CURB OR CURB AND GUTTER SHALL BE DONE IN ACCORDANCE WITH THE APPLICABLE PORTIONS OF SECTION 440 AND 606 OF THE STANDARD SPECIFICATIONS.

⑧ THE LOCATIONS OF REMOVAL AND REPLACEMENT OF EXISTING CURB OR CURB AND GUTTER SHALL BE DETERMINED BY THE RESIDENT ENGINEER AT THE TIME OF CONSTRUCTION.

CURB OR CURB AND GUTTER REMOVAL AND REPLACEMENT

ALL DIMENSIONS ARE IN INCHES (MILLIMETERS) UNLESS OTHERWISE SHOWN.

FILE NAME =	USER NAME = drivkasgn	DESIGNED - A. HOUSEH	REVISED - R. SHAH 10-03-96	STATE OF ILLINOIS DEPARTMENT OF TRANSPORTATION	CURB OR CURB AND GUTTER REMOVAL AND REPLACEMENT	F.A.U. RTE.	SECTION	COUNTY	TOTAL SHEETS	SHEET NO.
c:\p\work\p\dot\drivkasgn\d0108315\bc24.dgn		DRAWN -	REVISED - A. ABBAS 03-21-97			3549	19-00121-00-RS	DuPAGE	35	29
	PLOT SCALE = 50.000' / IN.	CHECKED -	REVISED - M. GOMEZ 01-22-01			BD600-06 (BD-24)		CONTRACT NO. 61G23		
	PLOT DATE = 12/15/2009	DATE - 03-11-94	REVISED - R. BORO 12-15-09			SCALE: NONE	SHEET NO. 1 OF 1 SHEETS	STA.	TO STA.	FED. ROAD DIST. NO. 1 ILLINOIS FED. AID PROJECT

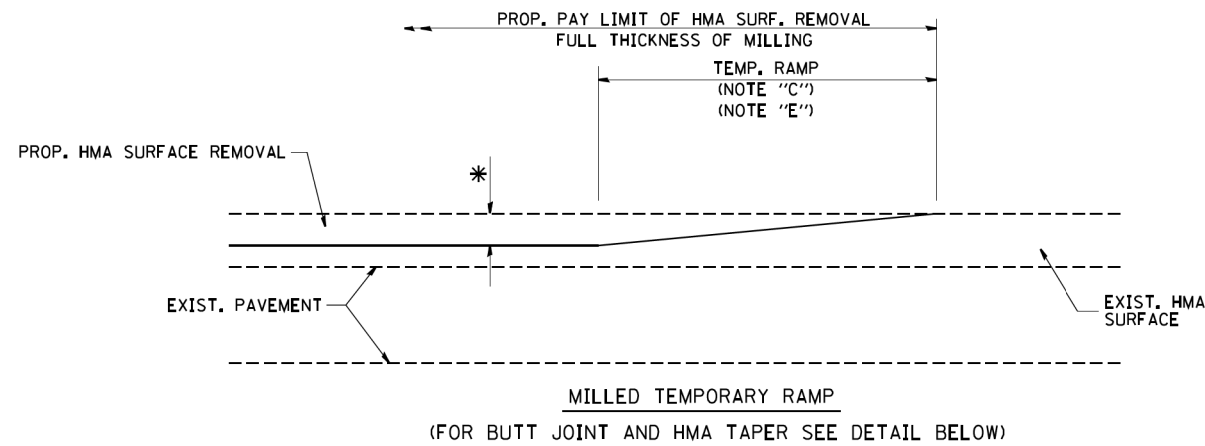

OPTION 1

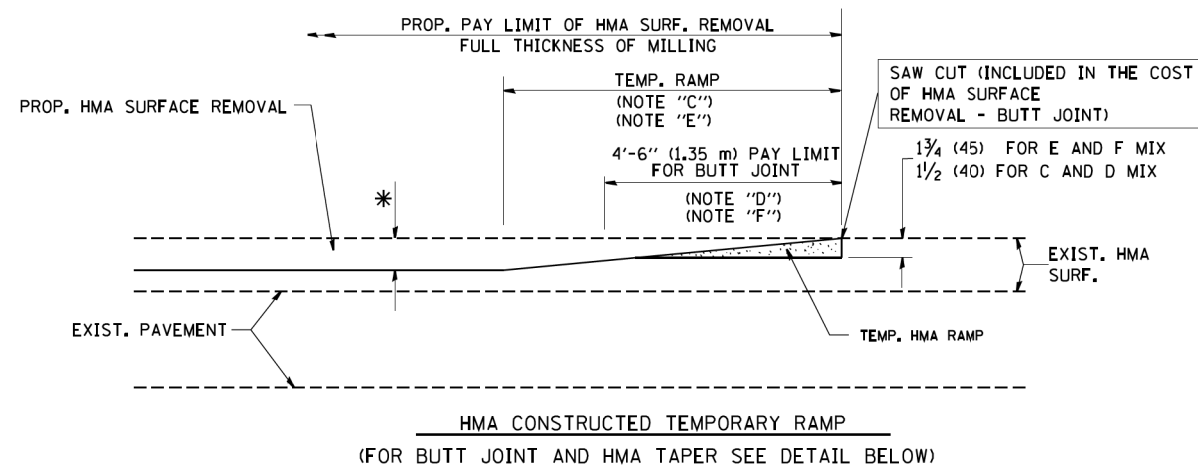

OPTION 2

TYPICAL TEMPORARY RAMP

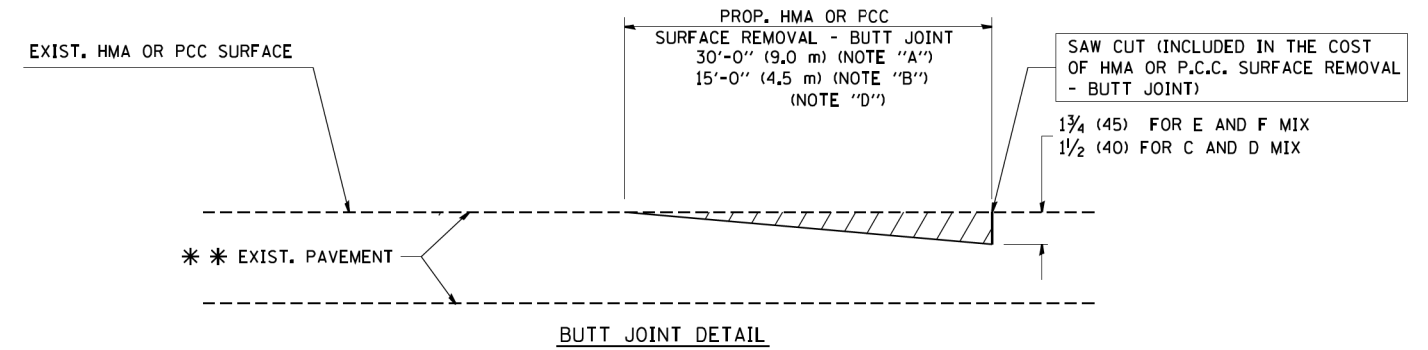

BUTT JOINT DETAIL

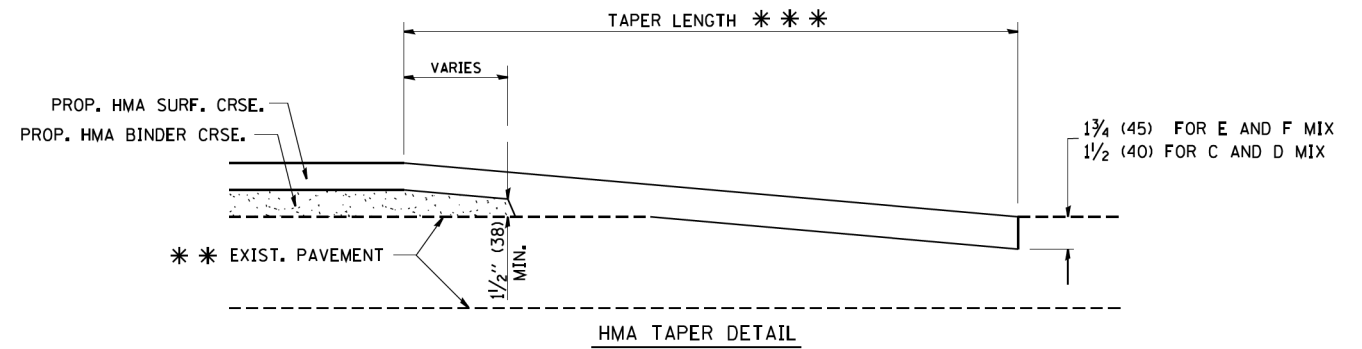

HMA TAPER DETAIL

TYPICAL BUTT JOINT AND HMA TAPER FOR RESURFACING ONLY

* * * PC CONCRETE, HMA OR HMA RESURFACED PAVEMENT.

NOTES

- A: MAINLINE ROADWAYS AND MAJOR SIDE ROADS.
 - B: MINOR SIDE ROADS.
 - C: THE TEMP. RAMP SHALL BE CONSTRUCTED IMMEDIATELY UPON REMOVAL OF THE EXISTING HMA SURFACE.
 - D: THE BUTT JOINT SHALL BE CONSTRUCTED IMMEDIATELY PRIOR TO PLACING THE PROPOSED HMA COURSES.
 - E: TAPER THE TEMP. RAMP AT A RATE OF 3'-0" (900 mm) PER 1 INCH (25 mm) OF MILLING THICKNESS.
 - F: INSTALLATION AND REMOVAL OF THE 4'-6" (1.35 m) TEMP. RAMP IS INCLUDED IN COST OF HMA SURFACE REMOVAL - BUTT JOINT
 - G: SEE ARTICLE 406.08 AND 406.14 OF THE STANDARD SPECIFICATIONS FOR "HMA AND/OR PCC SURFACE REMOVAL, BUTT JOINT".
- * SEE TYPICAL SECTIONS FOR MILLING THICKNESS.
- * * * 20'-0" (6.1 m) PER 1 (25) RESURFACING (NOTE "A")
10'-0" (3.0 m) PER 1 (25) RESURFACING (NOTE "B")

BASIS OF PAYMENT:

THE BUTT JOINT WILL BE PAID FOR AT THE CONTRACT UNIT PRICE PER SQUARE YARD (SQUARE METER) FOR "HOT-MIX ASPHALT SURFACE REMOVAL - BUTT JOINT" OR FOR "PORTLAND CEMENT CONCRETE SURFACE REMOVAL - BUTT JOINT".

ALL DIMENSIONS ARE IN INCHES (MILLIMETERS) UNLESS OTHERWISE SHOWN.

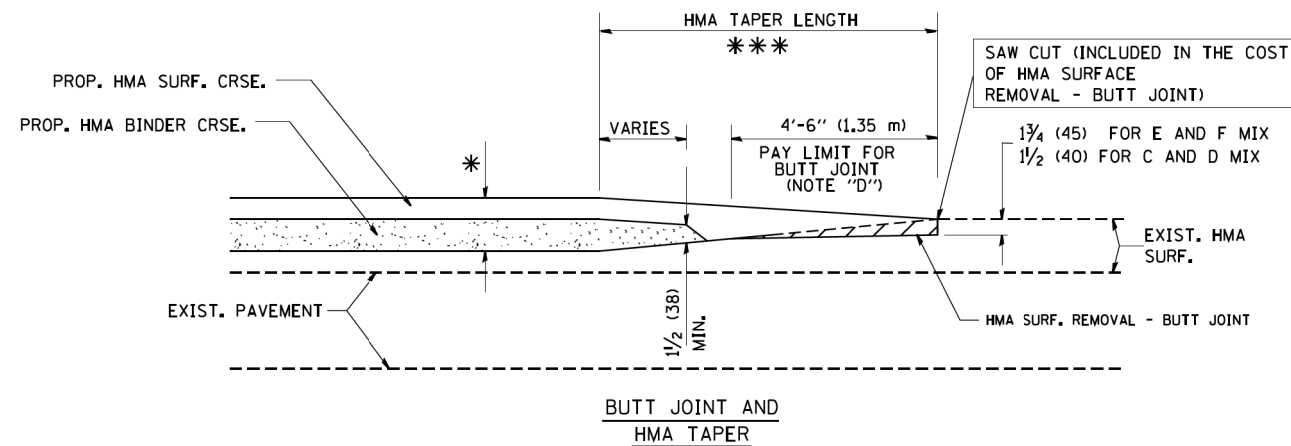

TYPICAL BUTT JOINT AND HMA TAPER FOR MILLING AND RESURFACING

FILE NAME = W:\distata\22x34\bd32.dgn	USER NAME = gegl1enobt	DESIGNED - M. DE YONG	REVISED - R. SHAH 10-25-94
		DRAWN -	REVISED - A. ABBAS 03-21-97
	PLOT SCALE = 50.0000' / IN.	CHECKED -	REVISED - M. GOMEZ 04-06-01
	PLOT DATE = 1/4/2008	DATE - 06-13-90	REVISED - R. BORO 01-01-07

**STATE OF ILLINOIS
DEPARTMENT OF TRANSPORTATION**

BUTT JOINT AND HMA TAPER DETAILS	
SCALE: NONE	SHEET NO. 1 OF 1 SHEETS STA. TO STA.

F.A.U. RTE. 3549	SECTION 19-00121-00-RS	COUNTY DuPAGE	TOTAL SHEETS 35	SHEET NO. 30
BD400-05 BD32		CONTRACT NO. 61G23		
FED. ROAD DIST. NO. 1 ILLINOIS FED. AID PROJECT				

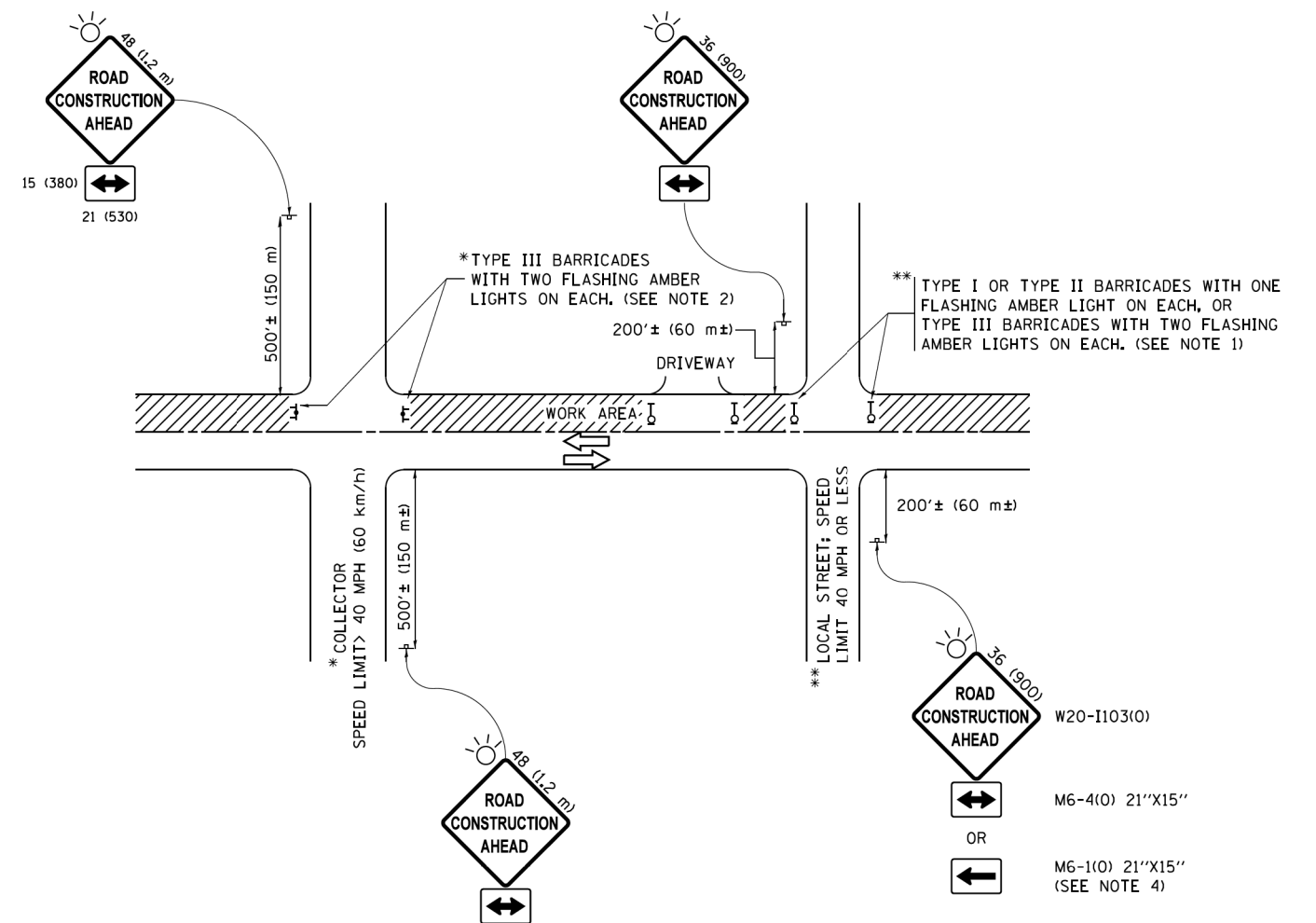

NOTES:

1. SIDE ROAD WITH A SPEED LIMIT OF 40 MPH (60 km/h) OR LESS AS SHOWN ON THE DRAWING AND AS DIRECTED BY THE ENGINEER:
 - a) ONE "ROAD CONSTRUCTION AHEAD" SIGN 36 x 36 (900x900) WITH A FLASHER MOUNTED ON IT APPROXIMATELY 200' (60 m) IN ADVANCE OF THE MAIN ROUTE.
 - b) THE CLOSED PORTION OF THE MAIN ROUTE SHALL BE PROTECTED BY BLOCKING WITH TYPE I, TYPE II OR TYPE III BARRICADES, 1/3 OF THE CROSS SECTION OF THE CLOSED PORTION.
2. SIDE ROAD WITH A SPEED LIMIT GREATER THAN 40 MPH (60 km/h) AS SHOWN ON THE DRAWING AND AS DIRECTED BY THE ENGINEER:
 - a) ONE "ROAD CONSTRUCTION AHEAD" SIGN 48 x 48 (1.2 m x 1.2 m) WITH A FLASHER MOUNTED ON IT APPROXIMATELY 500' (150 m) IN ADVANCE OF THE MAIN ROUTE.
 - b) THE CLOSED PORTION OF THE MAIN ROUTE SHALL BE PROTECTED BY BLOCKING WITH TYPE III BARRICADES, 1/2 OF THE CROSS SECTION OF THE CLOSED PORTION.
3. CONES MAY BE SUBSTITUTED FOR BARRICADES OR DRUMS AT HALF THE SPACING DURING DAY OPERATIONS. CONES SHALL BE A MINIMUM OF 28 (710) IN HEIGHT.
4. WHEN THE SIDE ROAD LIES BETWEEN THE BEGINNING OF THE MAINLINE SIGNING AND THE WORK ZONE, A SINGLE HEADED ARROW (M6-1) SHALL BE USED IN LIEU OF THE DOUBLE HEADED ARROW (M6-4).
5. WHEN WORK IS BEING PERFORMED ON A SIDE ROAD OR DRIVEWAY, FOLLOW THE APPLICABLE STANDARD(S). THE DIRECTIONAL ARROW (M6-1 OR M6-4) SHALL BE COVERED OR REMOVED WHEN NO LONGER CONSISTENT WITH THE TRAFFIC CONTROL SET-UP.
6. ADVANCE WARNING SIGNS ARE TO BE OMITTED ON DRIVEWAYS UNLESS OTHERWISE SPECIFIED IN THE PLANS OR BY THE ENGINEER.
7. THE TRAFFIC CONTROL AND PROTECTION FOR SIDE ROADS, INTERSECTIONS, AND DRIVEWAYS SHALL BE INCLUDED IN THE COST OF SPECIFIED TRAFFIC CONTROL STANDARDS OR ITEMS.

All dimensions are in inches (millimeters) unless otherwise shown.

FILE NAME =	USER NAME = footemj	DESIGNED - L.H.A.	REVISED - A. HOUSEH 10-15-96
pwt\11084EBID\INTEG\illinois.gov\FWIDOT\Documents\IDOT Offices\District 1\Projects\Dist		DRAWN	REVISED - T. RAMMACHER 01-06-00
Default	PLOT SCALE = 50,000' / 1" =	CHECKED -	REVISED - A. SCHUETZE 07-01-13
	PLOT DATE = 9/15/2016	DATE - 06-89	REVISED - A. SCHUETZE 09-15-16

**STATE OF ILLINOIS
DEPARTMENT OF TRANSPORTATION**

TRAFFIC CONTROL AND PROTECTION FOR SIDE ROADS, INTERSECTIONS, AND DRIVEWAYS			
SCALE: NONE	SHEET 1	OF 1 SHEETS	STA. TO STA.

F.A.U. RTE.	SECTION	COUNTY	TOTAL SHEETS	SHEET NO.
3549	19-00121-00-RS	DuPAGE	35	31
TC-10			CONTRACT NO. 61G23	
ILLINOIS FED. AID PROJECT				

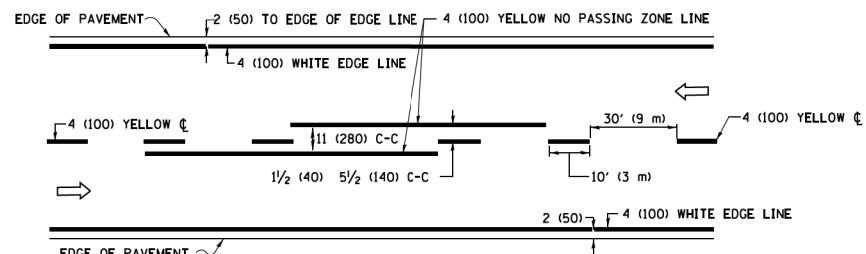

2-LANE ROADWAY

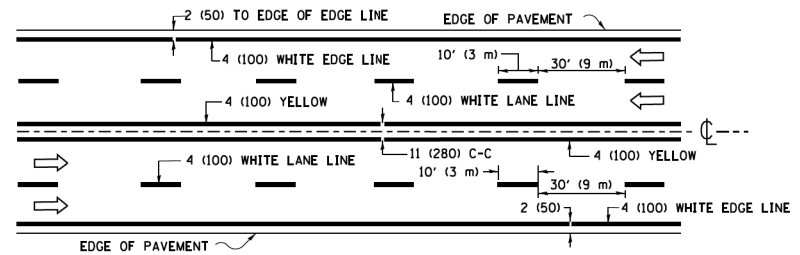

MULTI-LANE UNDIVIDED

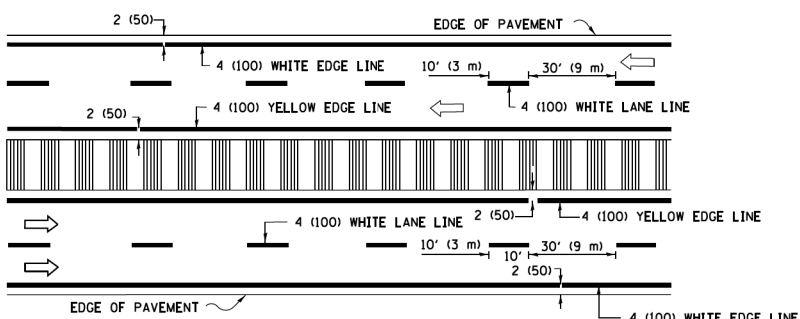

MULTI-LANE DIVIDED WITH MEDIAN

TYPICAL LANE AND EDGE LINE MARKING

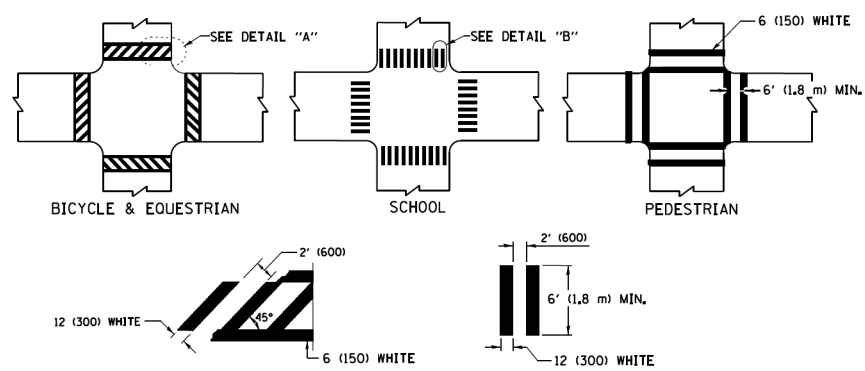

TYPICAL CROSSWALK MARKING

* MARKINGS SHALL BE INSTALLED PARALLEL TO THE CENTERLINE OF THE ROAD WHICH IT CROSSES

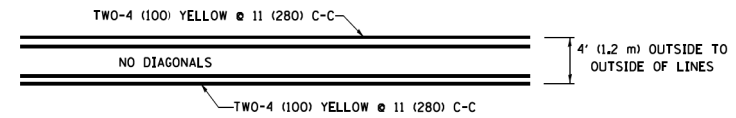

4' (1.2 m) WIDE MEDIANS ONLY

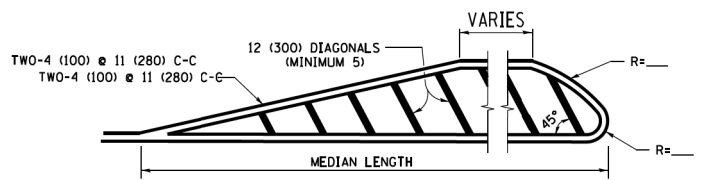

MEDIANS OVER 4' (1.2 m) WIDE

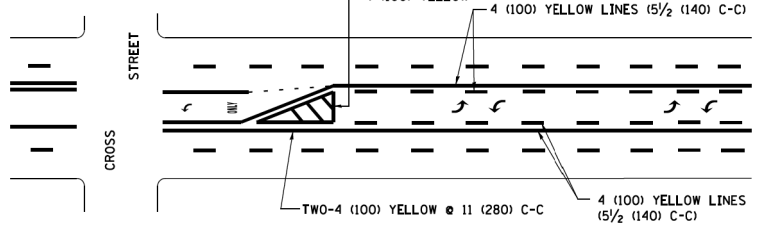

MEDIAN WITH TWO-WAY LEFT TURN LANE TYPICAL PAINTED MEDIAN MARKING

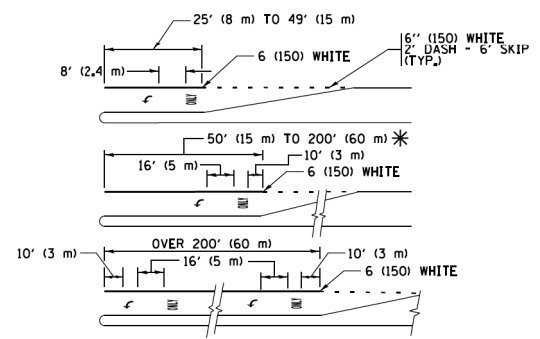

FULL SIZE LETTERS 8' (2.4 m) AND ARROWS SHALL BE USED. AREA = 15.6 SQ. FT. (1.5 m²) ONLY AREA = 20.8 SQ. FT. (1.9 m²)

* TURN LANES IN EXCESS OF 400' (120 m) IN LENGTH MAY HAVE AN ADDITIONAL SET OF ARROW - "ONLY" INSTALLED MIDWAY BETWEEN THE OTHER TWO SETS OF ARROW - "ONLY".

TYPICAL LEFT (OR RIGHT) TURN LANE TYPICAL TURN LANE MARKING

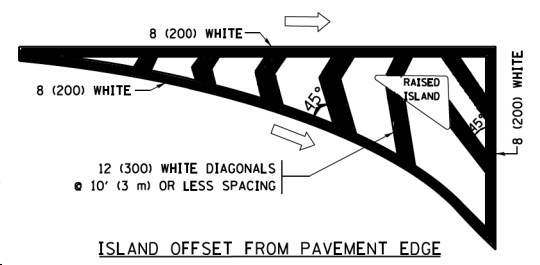

ISLAND OFFSET FROM PAVEMENT EDGE

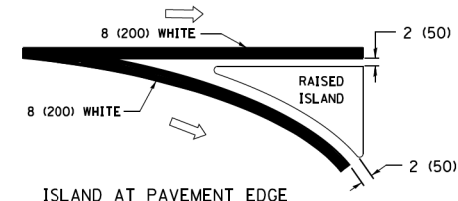

ISLAND AT PAVEMENT EDGE TYPICAL ISLAND MARKING

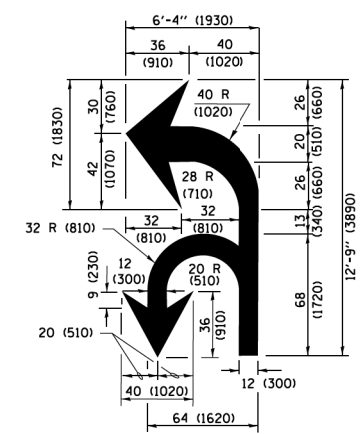

COMBINATION LEFT AND U-TURN

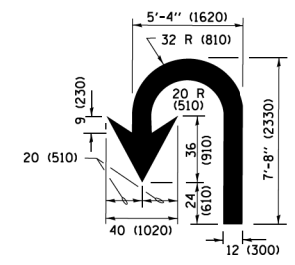

U-TURN

LANE REDUCTION TRANSITION

* LANE REDUCTION ARROWS REQUIRED AT SPEEDS OF 45 MPH OR GREATER OR WHEN SPECIFIED IN PLANS.

D(FT)	SPEED LIMIT
345	30
425	35
500	40
580	45
665	50
750	55

TYPE OF MARKING	WIDTH OF LINE	PATTERN	COLOR	SPACING /REMARKS
CENTERLINE ON 2 LANE PAVEMENT	4 (100)	SKIP-DASH	YELLOW	10' (3 m) LINE WITH 30' (9 m) SPACE
CENTERLINE ON MULTI-LANE UNDIVIDED PAVEMENT	2 @ 4 (100)	SOLID	YELLOW	11 (280) C-C
NO PASSING ZONE LINES FOR ONE DIRECTION FOR BOTH DIRECTIONS	4 (100) 2 @ 4 (100)	SOLID SOLID	YELLOW YELLOW	5/2 (140) C-C FROM SKIP-DASH CENTERLINE 11 (280) C-C OMIT SKIP-DASH CENTERLINE BETWEEN
LANE LINES	4 (100) 5 (125) ON FREEWAYS	SKIP-DASH SKIP-DASH	WHITE WHITE	10' (3 m) LINE WITH 30' (9 m) SPACE
DOTTED LINES (EXTENSIONS OF CENTER, LANE OR TURN LANE MARKINGS)	SAME AS LINE BEING EXTENDED	SKIP-DASH	SAME AS LINE BEING EXTENDED	2' (600) LINE WITH 6' (1.8 m) SPACE
EDGE LINES	4 (100)	SOLID	YELLOW-LEFT WHITE-RIGHT	OUTLINE MEDIANS IN YELLOW
TURN LANE MARKINGS	6 (150) LINE; FULL SIZE LETTERS & SYMBOLS (8' (2.4m))	SOLID	WHITE	SEE TYPICAL TURN LANE MARKING DETAIL
TWO WAY LEFT TURN MARKING	2 @ 4 (100) EACH DIRECTION 8' (2.4m) LEFT ARROW	SKIP-DASH AND SOLID IN PAIRS	YELLOW WHITE	10' (3 m) LINE WITH 30' (9 m) SPACE FOR SKIP-DASH; 5/2 (140) C-C BETWEEN SOLID LINE AND SKIP-DASH LINE SEE TYPICAL TWO-WAY LEFT TURN MARKING DETAIL
CROSSWALK LINES (PEDESTRIAN) A. DIAGONALS (BIKE & EQUESTRIAN) B. LONGITUDINAL BARS (SCHOOL)	2 @ 6 (150) 12 (300) @ 45° 12 (300) @ 90°	SOLID SOLID SOLID	WHITE WHITE WHITE	NOT LESS THAN 6' (1.8 m) APART 2' (600) APART 2' (600) APART SEE TYPICAL CROSSWALK MARKING DETAILS.
STOP LINES	24 (600)	SOLID	WHITE	PLACE 4' (1.2 m) IN ADVANCE OF AND PARALLEL TO CROSSWALK, IF PRESENT, OTHERWISE, PLACE AT DESIRED STOPPING POINT, PARALLEL TO CROSSROAD CENTERLINE, WHERE POSSIBLE
PAINTED MEDIANS	2 @ 4 (100) WITH 12 (300) DIAGONALS @ 45° NO DIAGONALS USED FOR 4' (1.2 m) WIDE MEDIANS	SOLID	YELLOW; TWO WAY TRAFFIC WHITE; ONE WAY TRAFFIC	11 (280) C-C FOR THE DOUBLE LINE SEE TYPICAL PAINTED MEDIAN MARKING.
CORE MARKING AND CHANNELIZING LINES	8 (200) WITH 12 (300) DIAGONALS @ 45°	SOLID	WHITE	DIAGONALS; 15' (4.5 m) C-C (LESS THAN 30MPH (50 km/h)) 20' (6 m) C-C (30 MPH (50 km/h) TO 45MPH (70 km/h)) 30' (9 m) C-C (OVER 45MPH (70 km/h))
RAILROAD CROSSING	24 (600) TRANSVERSE LINES; "RR" IS 6' (1.8 m) LETTERS; 16 (400) LINE FOR "X"	SOLID	WHITE	SEE STATE STANDARD 780001 AREA OF "RR" IS 6' (1.8 m) LETTERS; 16 (400) LINE FOR "X"
SHOULDER DIAGONALS (REQUIRED FOR SHOULDERS ≥ 8')	12 (300) @ 45°	SOLID	WHITE - RIGHT YELLOW - LEFT	50' (15 m) C-C (LESS THAN 30MPH (50 km/h)) 75' (25 m) C-C (30 MPH (50 km/h) TO 45MPH (70 km/h)) 150' (45 m) C-C (OVER 45MPH (70 km/h))
U TURN ARROW	SEE DETAIL	SOLID	WHITE	16.3 SF
2 ARROW COMBINATION LEFT AND U TURN	SEE DETAIL	SOLID	WHITE	30.4 SF

FOR FURTHER DETAILS ON PAVEMENT MARKING REFER TO STANDARD SPECIFICATIONS FOR ROAD AND BRIDGE CONSTRUCTION AND STATE STANDARD 780001.

All dimensions are in inches (millimeters) unless otherwise shown.

FILE NAME = W:\dststd\22x34\1013.dgn	USER NAME = lryss	DESIGNED - EVERS	REVISED - C. JUCIUS 09-09-09
Default	PLOT SCALE = 50,000 1" = 1 mi	DRAWN -	REVISED - C. JUCIUS 07-01-13
	PLOT DATE = 6/23/2017	CHECKED -	REVISED - C. JUCIUS 12-21-15
		DATE - 03-19-90	REVISED - C. JUCIUS 04-12-16

STATE OF ILLINOIS DEPARTMENT OF TRANSPORTATION

DISTRICT ONE		F.A.U. RTE.	SECTION	COUNTY	TOTAL SHEETS	SHEET NO.
TYPICAL PAVEMENT MARKINGS		3549	19-00121-00-RS	DuPAGE	35	32
SCALE: NONE	SHEET 1 OF 1 SHEETS	STA. TO STA.	ILLINOIS/FED. AID PROJECT			

DISTRICT ONE		F.A.U. RTE.	SECTION	COUNTY	TOTAL SHEETS	SHEET NO.
TYPICAL PAVEMENT MARKINGS		3549	19-00121-00-RS	DuPAGE	35	32
SCALE: NONE	SHEET 1 OF 1 SHEETS	STA. TO STA.	ILLINOIS/FED. AID PROJECT			

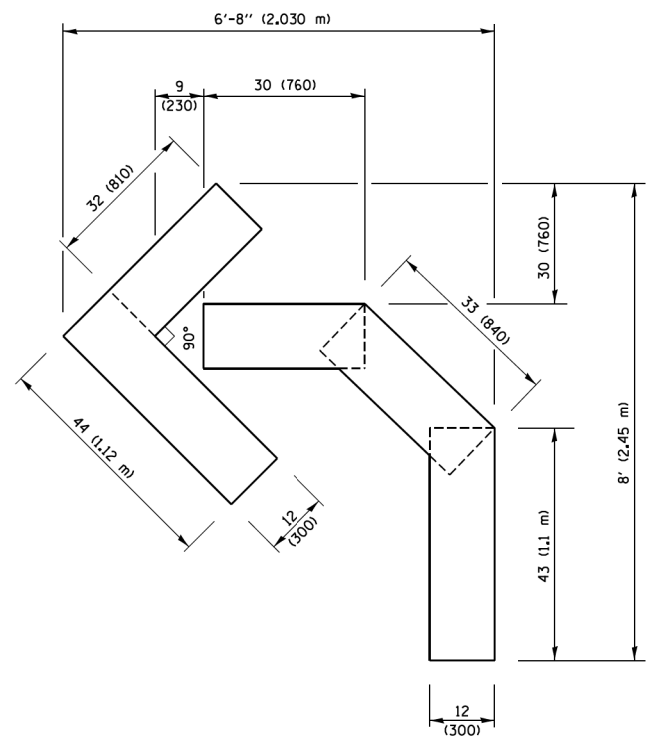

QUANTITY
 4 (100) LINE = 45.5 ft. (13.9 m)
 15.2 sq. ft. (1.41 sq. m)

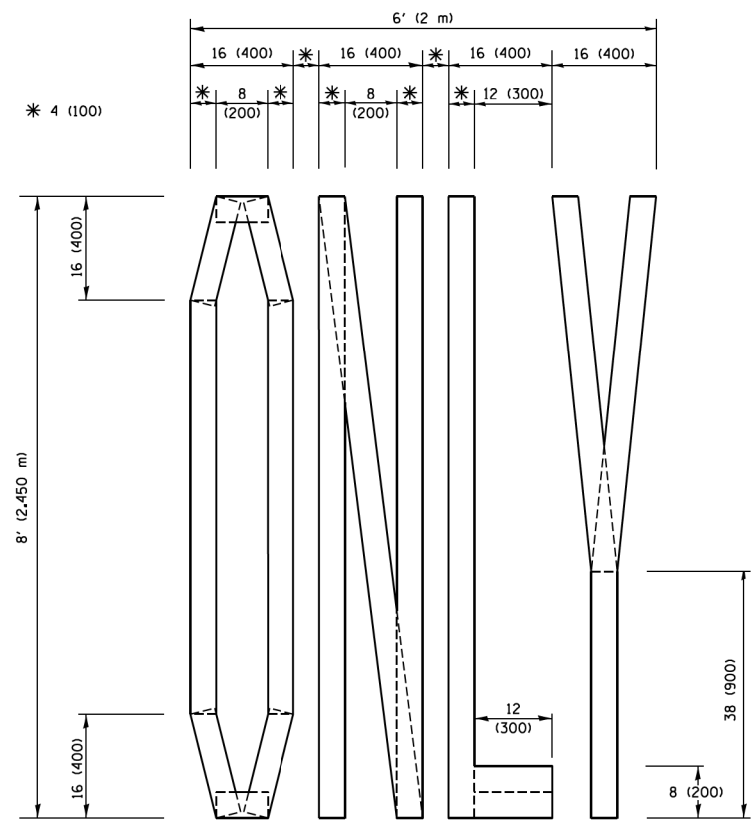

QUANTITY
 4 (100) LINE = 64.1 ft. (19.5 m)
 21.4 sq. ft. (1.99 sq. m)

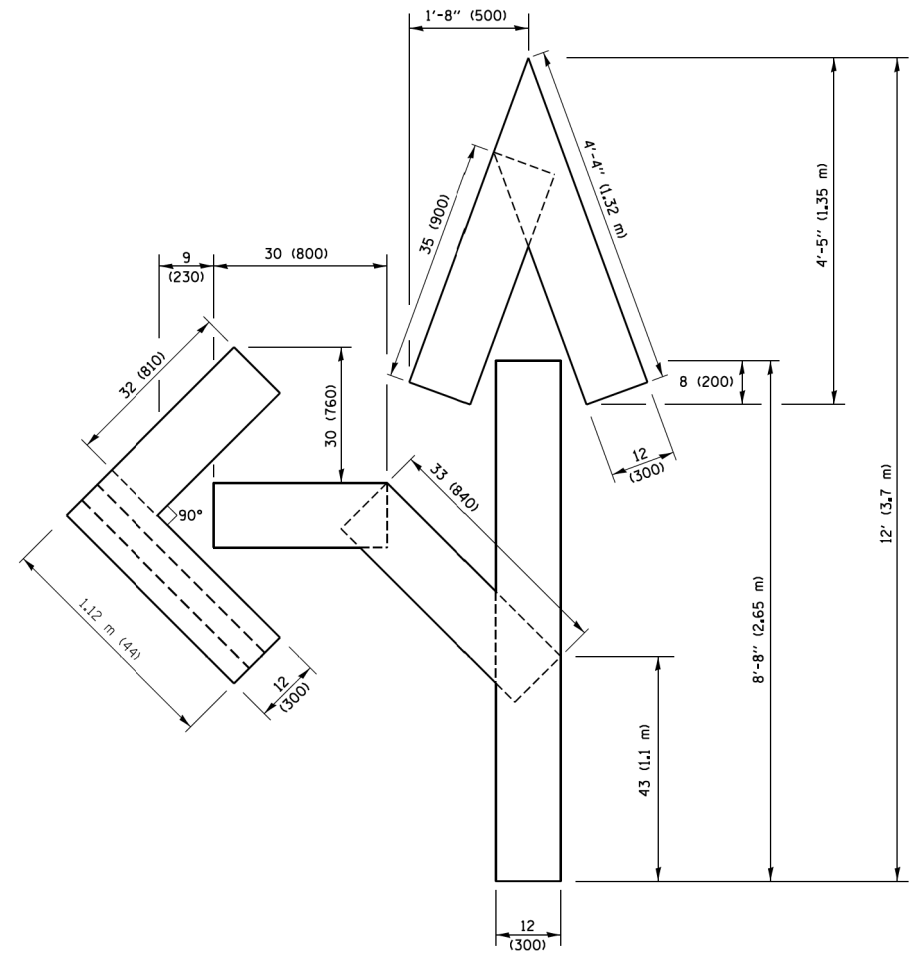

QUANTITY
 4 (100) LINE = 82.5 ft. (25.1 m)
 27.5 sq. ft. (2.53 sq. m)

NOTE:
 ALL QUANTITIES OF PLACEMENT ARE REPRESENTED IN LINEAR FEET OF 4" LINES TO MATCH THE 4" TEMPORARY TAPE PAY ITEM AND REPRESENTS THE TOTAL QUANTITY OF 4" TAPE REQUIRED.

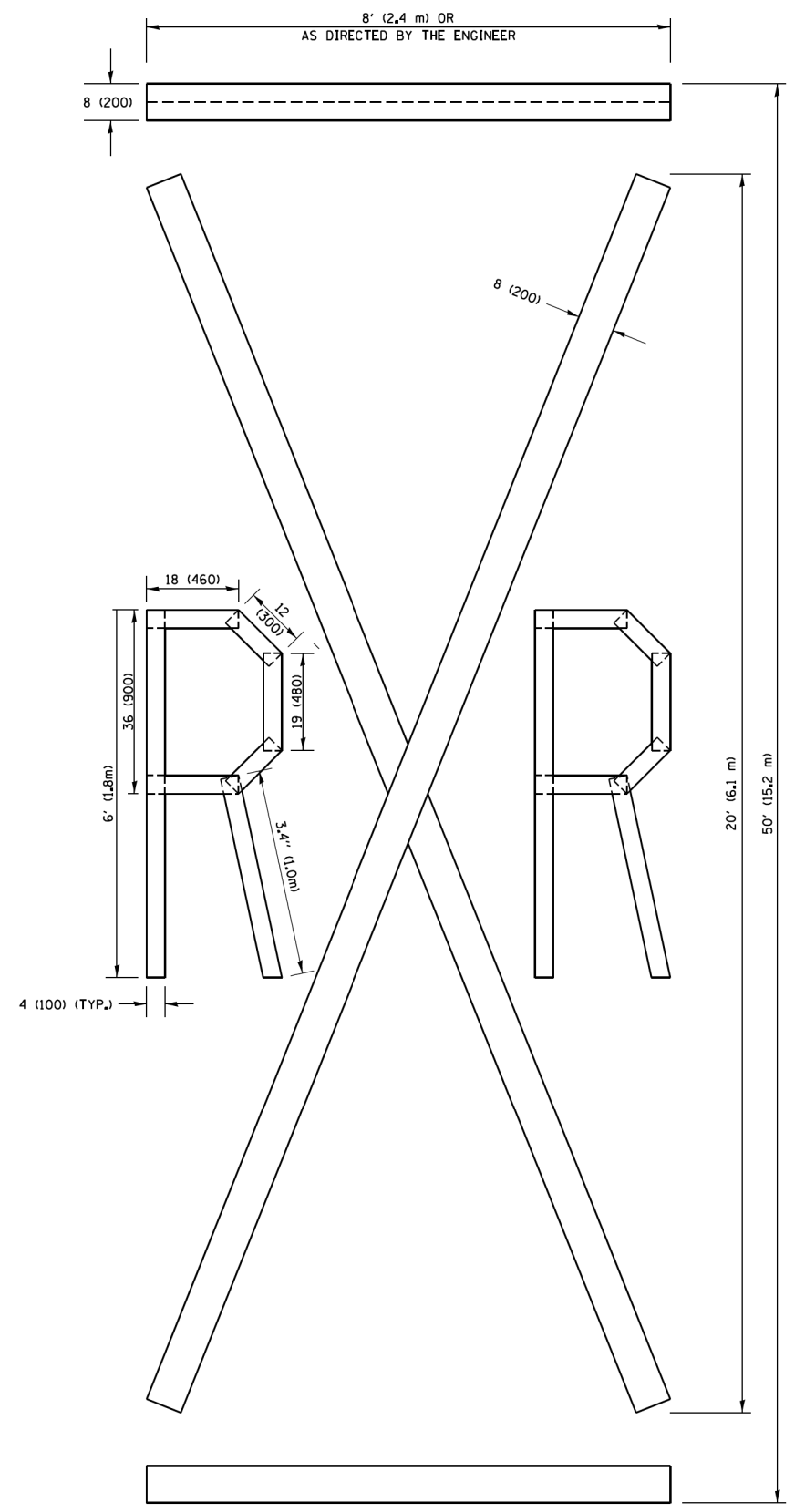

QUANTITY
 4 (100) LINE = 225.9 ft. (68.9 m)
 75.3 sq. ft. (6.99 sq. m)

All dimensions are in inches (millimeters) unless otherwise shown.

FILE NAME =	USER NAME = footemj	DESIGNED -	REVISED -T. RAMMACHER 03-02-98
pw\j\1084E81D\INTEG\illinois.gov\FWIDOT\Documents\JDOT_Offices\District 1\Projects\Dist 1\CADData\CADsheets\to16.dgn		DRAWN	REVISED -E. GOMEZ 08-28-00
PLOT SCALE = 50,0000 / 1"		CHECKED -	REVISED -E. GOMEZ 08-28-00
PLOT DATE = 9/15/2016		DATE -	REVISED -A. SCHUETZE 09-15-16

**STATE OF ILLINOIS
 DEPARTMENT OF TRANSPORTATION**

SHORT TERM PAVEMENT MARKING LETTERS AND SYMBOLS			
SCALE: NONE	SHEET NO. 1 OF 1 SHEETS	STA.	TO STA.

F.A.U. RTE.	SECTION	COUNTY	TOTAL SHEETS	SHEET NO.
3549	19-00121-00-RS	DuPAGE	35	33
TC-16		CONTRACT NO. 61G23		
FED. ROAD DIST. NO. 1 ILLINOIS FED. AID PROJECT				

LOOP DETECTOR NOTES

1. EACH PAIR OF LOOP WIRES SHALL BE PLACED IN A SEPARATE EMPTY COILABLE NONMETALLIC CONDUIT FROM THE EDGE OF PAVEMENT TO THE HANDHOLE. SPACING BETWEEN THE HOLES DRILLED IN THE PAVEMENT SHALL NOT BE LESS THAN 6" (150 mm). EMPTY COILABLE NONMETALLIC CONDUIT SHALL BE INCLUDED IN THE COST OF THE LOOP WIRE.
2. THE NUMBER OF LOOP TURNS SHALL BE AS RECOMMENDED BY THE AMPLIFIER MANUFACTURER. ALL ADJACENT SIDES OF THE LOOPS SHALL BE INSTALLED IN SUCH A WAY THAT THE CURRENT FLOW IS IN THE SAME DIRECTION TO REINFORCE ITS MAGNETIC FIELDS FOR SMALL VEHICLE DETECTION.
3. EACH LOOP LEAD-IN SHALL BE IDENTIFIED AND PERMANENTLY TAGGED IN THE HANDHOLE. EACH LEAD-IN CABLE TAG SHALL INDICATE THE LOCATION OF THE LOOP, LOOP ROTATION (CLOCKWISE/COUNTERCLOCKWISE), LOOP LEAD-IN DIRECTION (IN OR OUT), LOOP CABLE NUMBER AND LOCATION IN CABINET, AND NUMBER OF TURNS IN THE DETECTOR LOOPS IN WATER PROOF INK AS INDICATED ON THE DISTRICT 1 STANDARD TRAFFIC SIGNAL DESIGN DETAIL. THE CONTRACTOR SHALL MARK LOOP LOCATIONS ON RECORD DRAWINGS AND PRESENT TO THE ENGINEER AFTER FINAL INSPECTION. LOOPS SHALL BE MARKED BY LANE AND LOOP NUMBER. SEE DETAIL BELOW.
4. ALL LOOP CABLE SHALL BE FASTENED WITH PLASTIC TIE WRAP TO THE HANDHOLE HOOKS.
5. IN ASPHALT PAVEMENT, LOOPS SHOULD BE PLACED IN THE BINDER AND DIVEHOLES MARKED AT THE CURB WITH A SAW-CUT. THE SAW-CUT SHALL BE CUT IN ACCORDANCE WITH LOCAL AND E.P.A. DUST CONTROL REQUIREMENTS. DETECTOR LOOP(S) SHALL NOT BE INSTALLED IN WET CONDITIONS AND THE SAW-CUTS MUST BE FREE OF DEBRIS AND RESIDUE SUCH AS DUST AND WATER WHICH IS TO BE ACHIEVED BY THE USE OF COMPRESSED AIR, WIRE BRUSHING AND HEAT DRYING ACCORDING TO SEALANT MANUFACTURER REQUIREMENTS. THE DETECTOR WIRE SHALL BE HELD IN PLACE BY THE USE OF FORM WEDGES. WEDGES SHALL BE SPACED NO MORE THAN 18" (450 mm) APART.
6. LOOP SPLICES SHALL BE SOLDERED USING A SOLDERING IRON. BLOW TORCHES OR OTHER DEVICES WHICH OXIDIZE COPPER CABLE SHALL NOT BE ALLOWED FOR SOLDERING OPERATIONS. SEE DETAIL BELOW RIGHT.
7. PREFORMED DETECTOR LOOPS SHALL BE USED, AS SHOWN ON THE PLANS, WHERE NEW CONCRETE PAVEMENT IS PROPOSED. THE INSTALLATION OF PREFORMED LOOPS SHALL BE IN ACCORDANCE WITH THE DISTRICT 1 SPECIFICATIONS OR AS DIRECTED BY THE ENGINEER.

LOOP LEAD-IN CABLE TAG

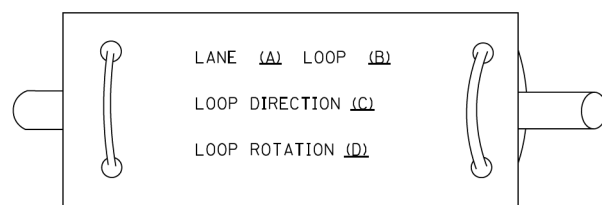

- A. LANE 1 IS THE LANE CLOSEST TO THE CENTERLINE OF THE ROADWAY
- B. LOOP #1 IS THE LOOP IN THE LANE CLOSEST TO THE INTERSECTION.
- C. LABEL LOOP CABLE "IN" OR LOOP CABLE "OUT".
- D. LABEL LOOP CABLE CLOCKWISE OR LOOP CABLE COUNTERCLOCKWISE.

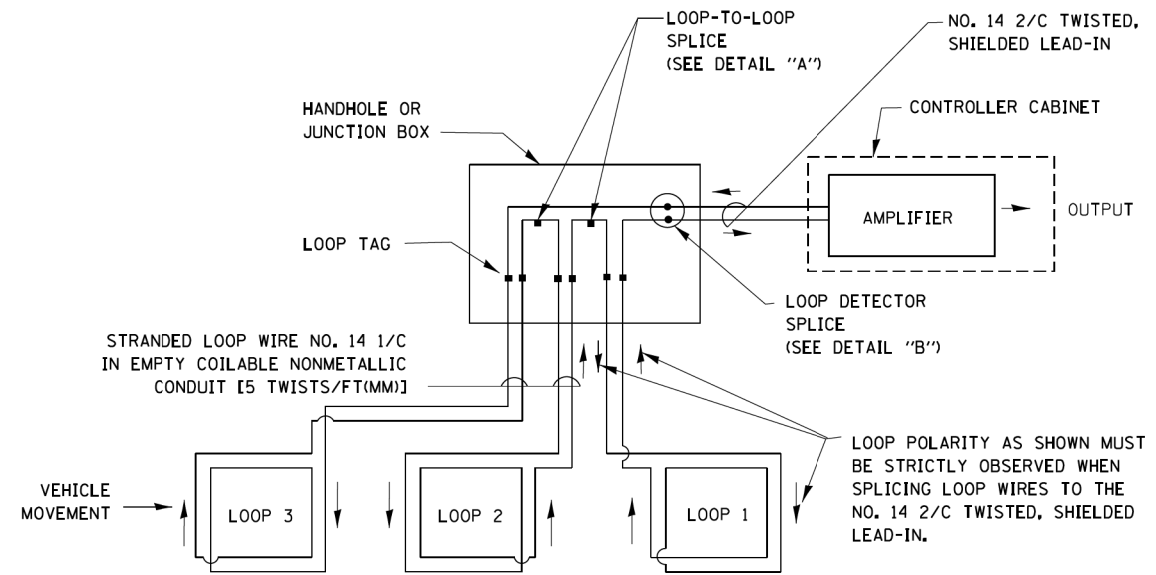

DETECTOR LOOP WIRING SCHEMATIC

- LOOPS SHALL BE SPLICED IN SERIES.
- SAW-CUTS SHALL BE A MINIMUM WIDTH OF 5/16" (8 mm).
- SAW-CUT DEPTHS SHALL BE 3" (75 mm). IF IN CONCRETE, THE SAW-CUT DEPTH SHALL BE TO THE TOP OF THE REINFORCEMENT.
- LOOP CORNERS SHALL BE DRILLED WITH A 2" (50 mm) DIAMETER CORE.

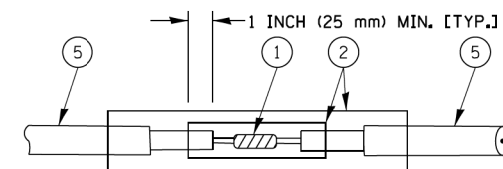

DETAIL "A"
LOOP-TO-LOOP SPLICE

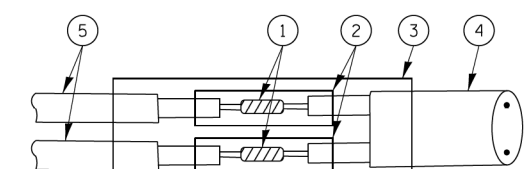

DETAIL "B"
LOOP-TO-CONTROLLER SPLICE

TYPE I LOOP

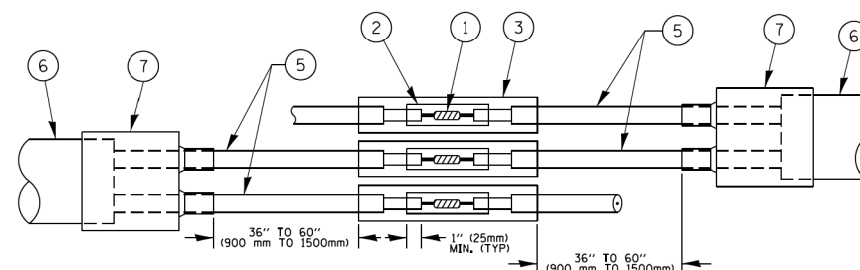

DETAIL "A"
LOOP-TO-LOOP SPLICE

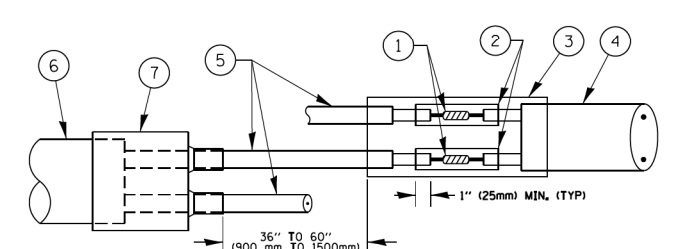

DETAIL "B"
LOOP-TO-CONTROLLER SPLICE

PREFORMED LOOP

LOOP DETECTOR SPLICE

- 1 WESTERN UNION SPLICE SOLDERED WITH ROSIN CORE FLUX. ALL EXPOSED SURFACES OF THE SOLDER SHALL BE SMOOTH. THE WESTERN UNION SPLICES SHALL BE STAGGERED.
- 2 WCSMW 30/100 HEAT SHRINK TUBE, MINIMUM LENGTH 3" (75 mm), UNDERWATER GRADE.
- 3 WCS 200/750 HEAT SHRINK TUBE, MINIMUM LENGTH 6" (150 mm), UNDERWATER GRADE.
- 4 NO. 14 2/C TWISTED, SHIELDED CABLE.
- 5 LOOP CONDUCTOR WITH FLEXIBLE PLASTIC TUBE.
- 6 PREFORMED LOOP
- 7 XL POLYOLEFIN 2 CONDUCTOR BREAKOUT SEALS, TFCO-CBR-2 OR APPROVED EQUAL

FILE NAME =	USER NAME = footemj	DESIGNED - DAD	REVISED - DAG 1-1-14
ca:\p\work\p\dot\Footemj\d0108315\ts05.dgn		DRAWN - BCK	REVISED -
	PLOT SCALE = 50.0000' / in.	CHECKED - DAD	REVISED -
	PLOT DATE = 1/13/2014	DATE - 10-28-09	REVISED -

**STATE OF ILLINOIS
DEPARTMENT OF TRANSPORTATION**

**DISTRICT ONE
STANDARD TRAFFIC SIGNAL DESIGN DETAILS**

SCALE: NONE SHEET NO. 2 OF 7 SHEETS STA. TO STA.

F.A.U. RTE.	SECTION	COUNTY	TOTAL SHEETS	SHEET NO.
3549	19-00121-00-RS	DuPAGE	35	34
TS-05		CONTRACT NO. 61G23		
FED. ROAD DIST. NO. 1 ILLINOIS FED. AID PROJECT				

