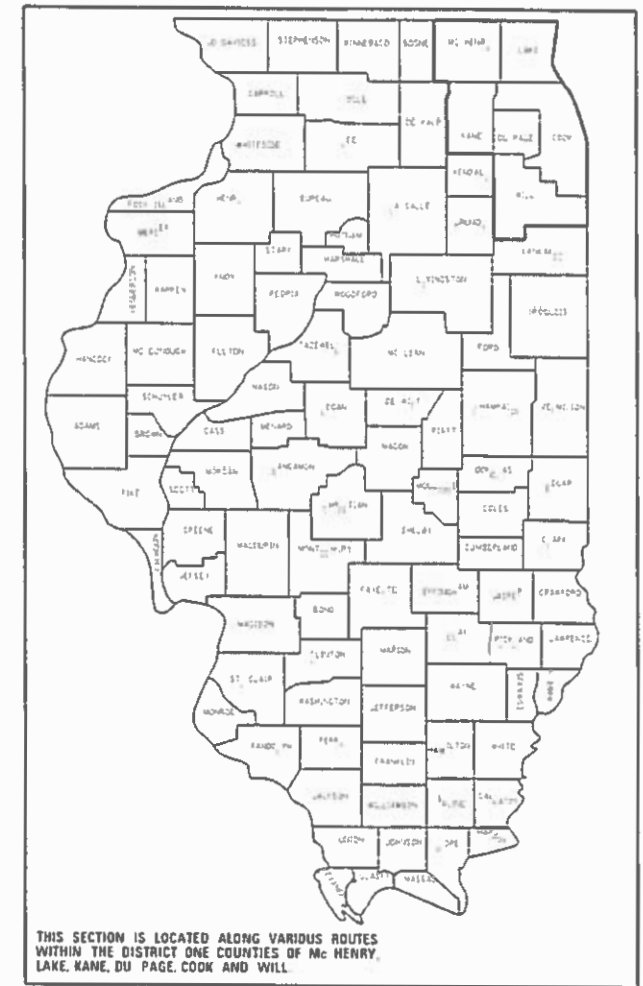


STATE OF ILLINOIS  
DEPARTMENT OF TRANSPORTATION

F.A. R.T.E.	SECTION	COUNTY	TOTAL SHEET NO.
VAR	2019-138-1	VARIOUS	21
		ILLINOIS	CONTRACT NO. 62K12

D-91-285-20



FOR INDEX OF SHEETS, SEE SHEET NO. 2

# PROPOSED HIGHWAY PLANS

ROUTE: VARIOUS EXPRESSWAYS AND ARTERIAL  
HIGHWAYS - DISTRICT ONE

SECTION: 2019-138-1

FENCE REPAIR

COUNTY: VARIOUS

C-91-068-20

SEE LOCATION MAPS  
SHEETS 4 THRU 12

C.U.A.N.  
CHICAGO UTILITY ALERT NETWORK  
1-312-744-7000

J.U.L.I.E.  
JOINT UTILITY LOCATION INFORMATION FOR EXCAVATION  
1-800-892-0123  
OR 811

PROJECT ENGINEER: J. ALAIN MIDY (847) 221-3056  
PROJECT MANAGER: FAWAD AQUEEL (847) 705-4247

CONTRACT NO. 62K12

STATE OF ILLINOIS  
DEPARTMENT OF TRANSPORTATION

SUBMITTED DECEMBER 17 20 19

*Anthony J. Rungtly* REGIONAL ENGINEER

Jun 31 20 20

*Scott A. Etk* ENGINEER OF DESIGN AND ENVIRONMENT

Jun 31 20 20

*James J. Dan* DIRECTOR OF HIGHWAYS PLANNING AND IMPLEMENTATION

PRINTED BY THE AUTHORITY  
OF THE STATE OF ILLINOIS

**INDEX OF SHEETS**

1. TITLE SHEET
2. INDEX OF SHEETS  
LIST OF APPLICABLE STATE STANDARDS
3. SUMMARY OF QUANTITIES
4. COOK COUNTY (SOUTH OF ILL 38) LOCATION MAP
5. DUPAGE COUNTY (SOUTH OF ILL 38) LOCATION MAP
6. KANE COUNTY (SOUTH OF ILL 38) LOCATION MAP
7. WILL COUNTY LOCATION MAP
8. COOK COUNTY (NORTH OF ILL 38) LOCATION MAP
9. DUPAGE COUNTY (NORTH OF ILL 38) LOCATION MAP
10. KANE COUNTY (NORTH OF ILL 38) LOCATION MAP
11. LAKE COUNTY LOCATION MAP
12. MCHENRY COUNTY LOCATION MAP
13. DETAILS OF PEDESTRIAN BARRIER TYPE III (STD. 10-SS-514R)
14. CHAIN LINK FENCE (STD. 10-SS-506B)
15. CHAIN LINK FENCE POST SLEEVE REPAIR DETAIL
16. PROPOSED PEDESTRIAN BARRIER AND CHAIN LINK FENCE  
WITH TENSION WIRE AND FENCE RAIL REMOVAL
17. SPECIAL FENCE DETAILS
18. ENTRANCE AND EXIT RAMP CLOSURE DETAILS (TC-08)
19. TRAFFIC CONTROL AND PROTECTION FOR SIDE ROADS,  
INTERSECTIONS AND DRIVEWAYS (TC-10)
20. TRAFFIC CONTROL AND PROTECTION AT TURN BAYS (TO REMAIN  
OPEN TO TRAFFIC) (TC-14)
21. TRAFFIC CONTROL DETAILS FOR SHOULDER CLOSURE AND  
PARTIAL RAMP CLOSURES (TC-17)

**GENERAL NOTES**

BEFORE STARTING ANY EXCAVATION, THE CONTRACTOR SHALL CALL "J.U.L.I.E." AT (800) 892-0123 OR 811 FOR FIELD LOCATIONS OF BURIED ELECTRIC, TELEPHONE AND GAS UTILITIES. 48 HOUR NOTIFICATION IS REQUIRED.

THE CONTRACTOR SHALL CONTACT THE DISTRICT ONE TRAFFIC CONTROL SUPERVISOR AT (847) 705-4155 FOR EXPRESSWAYS AND KALPANA.KANNAN-HOSAGURGA@ILLINOIS.GOV FOR ARTERIALS, A MINIMUM OF 72 HOURS IN ADVANCE OF BEGINNING WORK.

THE CONTRACTOR SHALL SUBMIT ALL DAILY LANE, RAMP AND SHOULDER CLOSURES VIA WWW.IDOTLCS.COM AT LEAST 24 HOURS IN ADVANCE OF ALL DAILY LANE, AND RAMP AND SHOULDER CLOSURES. THE CONTRACTOR SHALL REQUEST AND GAIN THE APPROVAL FROM THE ILLINOIS DEPARTMENT OF TRANSPORTATION'S EXPRESSWAY TRAFFIC OPERATIONS ENGINEER AT (847) 705-4151 OR (847) 705-4155.

\* MOVING LANE CLOSURES WILL NOT BE PERMITTED ON EXPRESSWAYS

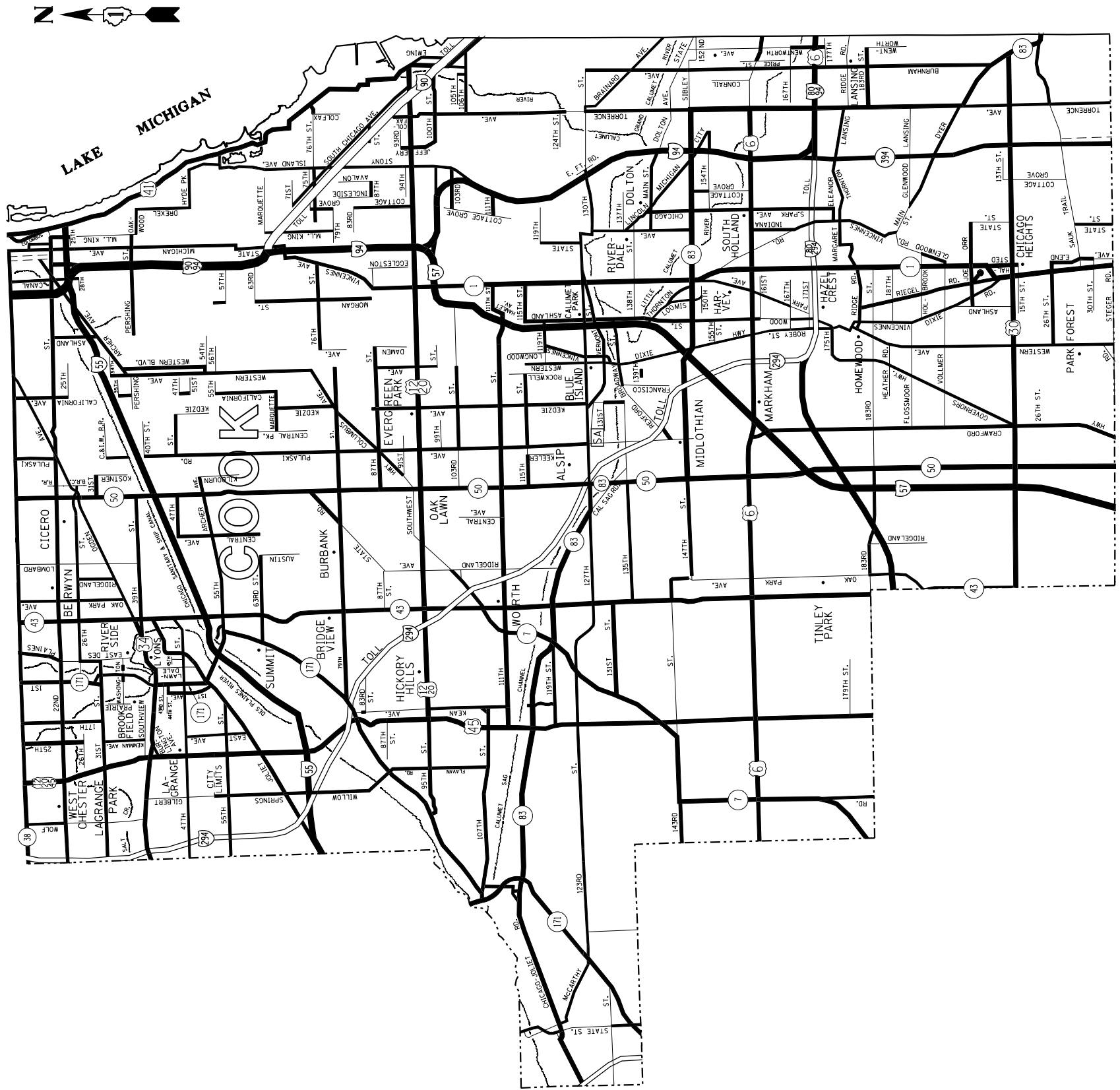
**STATE STANDARDS**

**DESCRIPTION**

664001-02	CHAIN LINK FENCE
665001-02	WOVEN WIRE FENCE
701001-02	OFF-RD OPERATIONS, 2L, 2W, MORE THAN 15' AWAY
701006-05	OFF-RD OPERATIONS, 2L, 2W, 15' TO 24" FROM PAVEMENT EDGE
701011-04	OFF-RD OPERATIONS, 2L, 2W, DAY ONLY
701101-05	OFF-RD OPERATIONS, MULTILANE, 15' TO 24" FROM PAVEMENT EDGE
701106-02	OFF-RD OPERATIONS, MULTILANE, MORE THAN 15' AWAY
701301-04	LANE CLOSURE, 2L, 2W, SHORT TIME OPERATIONS
701306-04	LANE CLOSURE, 2L, 2W, SLOW MOVING OPERATIONS DAY ONLY, FOR SPEEDS ≥ 45 MPH
701311-03	LANE CLOSURE, 2L, 2W, MOVING OPERATIONS DAY ONLY
701336-07	LANE CLOSURE, 2L, 2W, WORK AREAS IN SERIES, FOR SPEEDS > 45 MPH
701400-09	APPROACH TO LANE CLOSURE, FREEWAY/ EXPRESSWAY
701401-12	LANE CLOSURE, FREEWAY/ EXPRESSWAY
701411-09	LANE CLOSURE, MULTILANE, AT ENTRANCE OR EXIT RAMP, FOR SPEEDS > 45 MPH
701421-08	LANE CLOSURE, MULTILANE, DAY OPERATIONS ONLY, FOR SPEEDS > 45 MPH TO 55 MPH
701422-10	LANE CLOSURE, MULTILANE, FOR SPEEDS > 45 MPH TO 55 MPH
* 701426-09	LANE CLOSURE, MULTILANE, INTERMITTENT OR MOVING OPERATIONS, FOR SPEEDS > 45 MPH
701427-05	LANE CLOSURE, MULTILANE, INTERMITTANT OR MOVING OPERATIONS < 40 MPH
701428-01	TRAFFIC CONTROL SETUP AND REMOVAL FREEWAY/ EXPRESSWAY
701501-06	URBAN LANE CLOSURE, 2L, 2W, UNDIVIDED
701601-09	URBAN LANE CLOSURE, MULTILANE, 1W OR 2W, WITH NONTRAVERSABLE MEDIAN
701602-10	URBAN LANE CLOSURE, MULTILANE, 2W WITH BIDIRECTIONAL LEFT TURN LANE
701606-10	URBAN LANE CLOSURE, MULTILANE, 2W WITH MOUNTABLE MEDIAN
701701-10	URBAN LANE CLOSURE, MULTILANE INTERSECTION
701801-06	SIDEWALK, CORNER OR CROSSWALK CLOSURE
701901-08	TRAFFIC CONTROL DEVICES

SUMMARY OF QUANTITIES			TOTAL QUANTITIES	CONSTRUCTION TYPE CODE 0021				
CODE NO	ITEM	UNIT		100% STATE 0021	100% MCHD 0021			
66400505	CHAIN LINK FENCE, 8'	FOOT	348	270	78			
66500105	WOVEN WIRE FENCE, 4'	FOOT	5291	4232	1059			
X6640100	FENCE RAIL REMOVAL	FOOT	3223	2527	696			
X6640300	CHAIN LINK FENCE REMOVAL	FOOT	81	64	17			
X6640309	CHAIN LINK GATES (SPECIAL)	SO FT	1218	952	266			
X6640590	CHAIN LINK FENCE POST SLEEVE REPAIR	EACH	70	55	15			
Z0009600	CHAIN LINK FABRIC, SPECIAL, 5' -0"	FOOT	36	28	8			
Z0009700	CHAIN LINK FABRIC, SPECIAL, 6' -0"	FOOT	2687	2121	566			
Z0009800	CHAIN LINK FABRIC, SPECIAL, 7' -0"	FOOT	15	11	4			
Z0009810	CHAIN LINK FABRIC, SPECIAL, 8' -0"	FOOT	106	83	23			
Z0009900	CHAIN LINK FABRIC, TYPE 1, 4' -0"	FOOT	29215	22835	6380			
Z0010300	CHAIN LINK FABRIC, TYPE 3, SPECIAL	FOOT	696	544	152			
Z0020210	PULL POST ARRANGEMENT	EACH	4	2	2			
Z0033200	LINE POST, TYPE 1	EACH	1253	980	273			
Z0033305	LINE POST, TYPE 3 SPECIAL	EACH	36	28	8			
Z0042500	POST, SPECIAL	EACH	138	107	31			

SUMMARY OF QUANTITIES			TOTAL QUANTITIES	CONSTRUCTION TYPE CODE 0021				
CODE NO	ITEM	UNIT		100% STATE 0021	100% MCHD 0021			
Z0042505	POST REMOVAL AND REPLACEMENT	EACH	9	7	2			
Z0074000	TERMINAL POST, TYPE 1	EACH	70	55	15			
Z0074010	TERMINAL POST, TYPE 3 SPECIAL	EACH	9	7	2			



DISTRICT NO. 1  
MAINTENANCE DESIGNATIONS

- VARIOUS COLORS STATE HIGHWAYS & EXPRESSWAYS
- TOLLWAY
- █ CITY MAINTENANCE AGREEMENTS
- - - - FUTURE HIGHWAYS
- VARIOUS AGENCIES HIGHWAYS

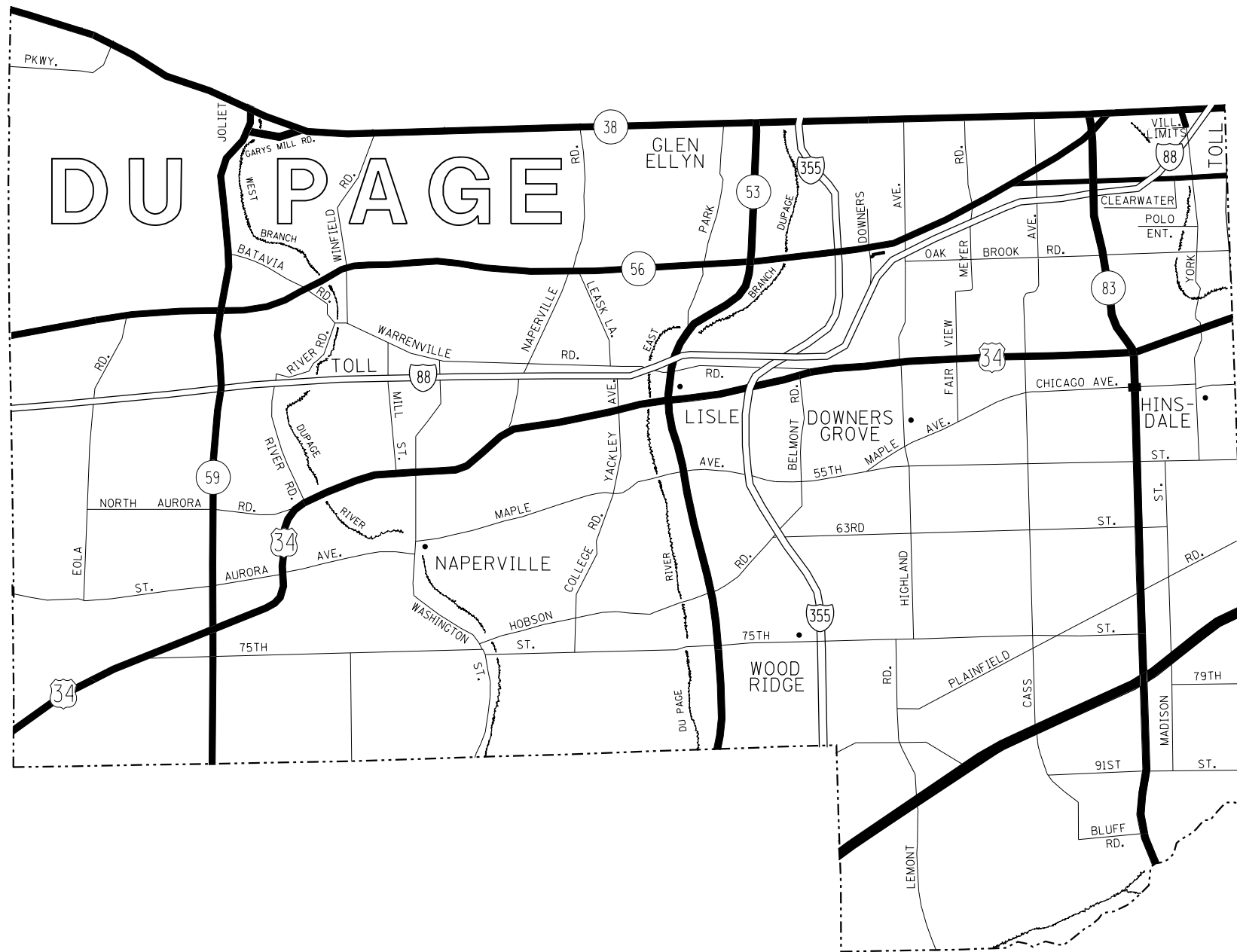
FILE NAME =	USER NAME = midyja	DESIGNED -	REVISED -
p:\planroom.dot\illinois.gov\PIDOT\Documents\IDOT Offices\District 1\Projects\0144815\Drawings\Design\0144816-sht-plan.dgn		DRAWN -	REVISED -
Default	PLOT SCALE = 100.0000' / in.	CHECKED -	REVISED -
	PLOT DATE = 12/7/2019	DATE -	REVISED -

STATE OF ILLINOIS  
DEPARTMENT OF TRANSPORTATION

FENCE REPAIR LOCATION MAP - COOK COUNTY  
SOUTH OF IL RTE 38

SCALE: SHEET OF SHEETS STA. TO STA.

F.A. RTE.	SECTION	COUNTY	TOTAL SHEETS	SHEET NO.
VAR	2019-138-1	VARIOUS	21	4
			CONTRACT NO. 62K12	
ILLINOIS FED. AID PROJECT				



DISTRICT NO. 1  
MAINTENANCE DESIGNATIONS

- VARIOUS COLORS STATE HIGHWAYS & EXPRESSWAYS
- TOLLWAY
- CITY MAINTENANCE AGREEMENTS
- FUTURE HIGHWAYS
- VARIOUS AGENCIES HIGHWAYS

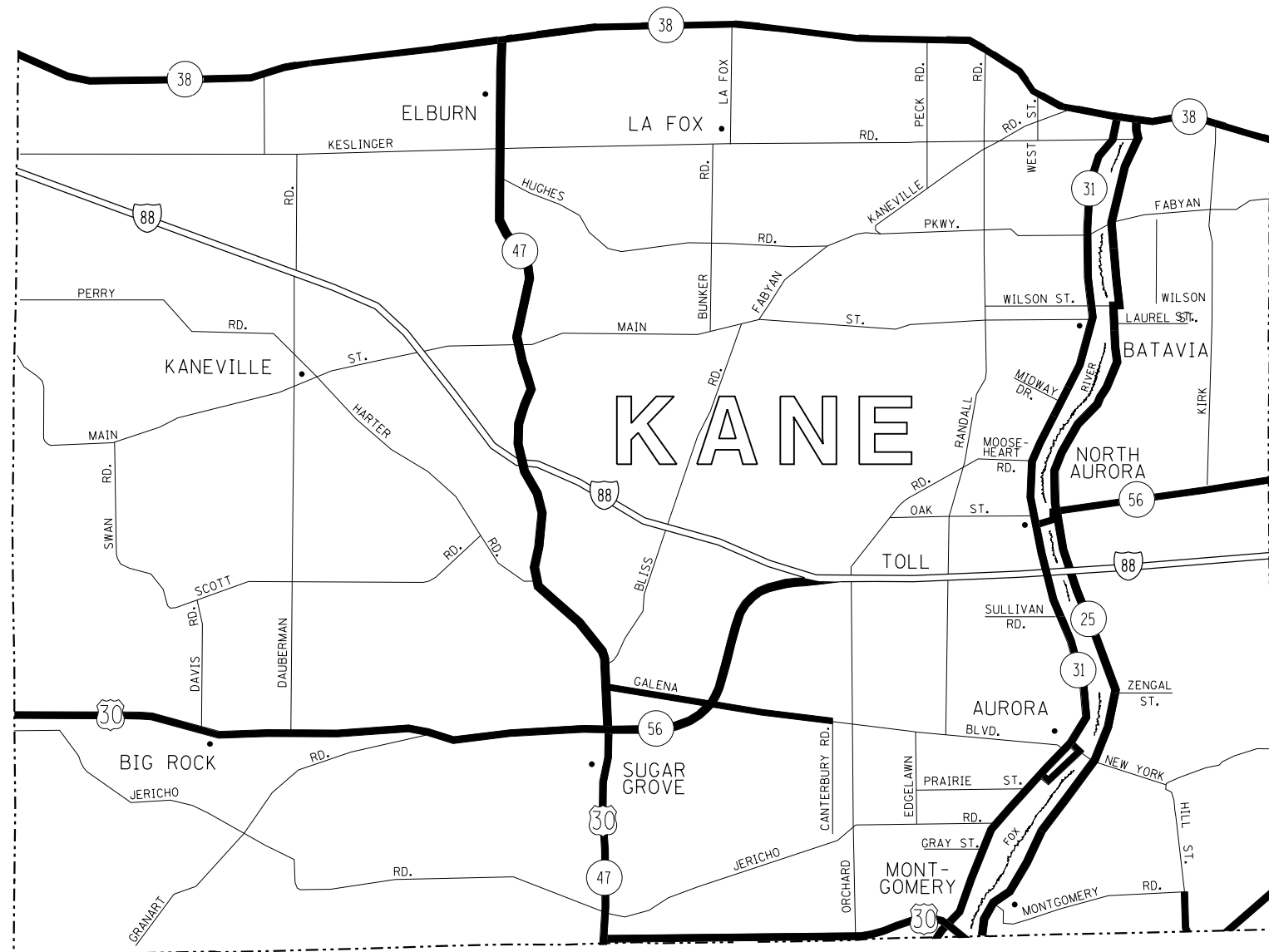
FILE NAME =	USER NAME = midyja	DESIGNED -	REVISED -
pw:\planroom.dot.illinois.gov\PIDOT\Documents\IDOT Offices\District 1\Projects\0144816\Design\0144816-sht-plan.dgn		DRAWN -	REVISED -
Default	PLOT SCALE = 100.0000' / in.	CHECKED -	REVISED -
	PLOT DATE = 12/7/2019	DATE -	REVISED -

**STATE OF ILLINOIS  
DEPARTMENT OF TRANSPORTATION**

**FENCE REPAIR LOCATION MAP - DuPAGE COUNTY  
SOUTH OF IL RTE 38**

SCALE:      SHEET      OF      SHEETS      STA.      TO      STA.

F.A. RTE.	SECTION	COUNTY	TOTAL SHEETS	SHEET NO.
VAR	2019-138-1	VARIOUS	21	5
CONTRACT NO. 62K12				
ILLINOIS FED. AID PROJECT				



DISTRICT NO. 1  
MAINTENANCE DESIGNATIONS

- VARIOUS COLORS STATE HIGHWAYS & EXPRESSWAYS
- ==== TOLLWAY
- ==== CITY MAINTENANCE AGREEMENTS
- FUTURE HIGHWAYS
- VARIOUS AGENCIES HIGHWAYS

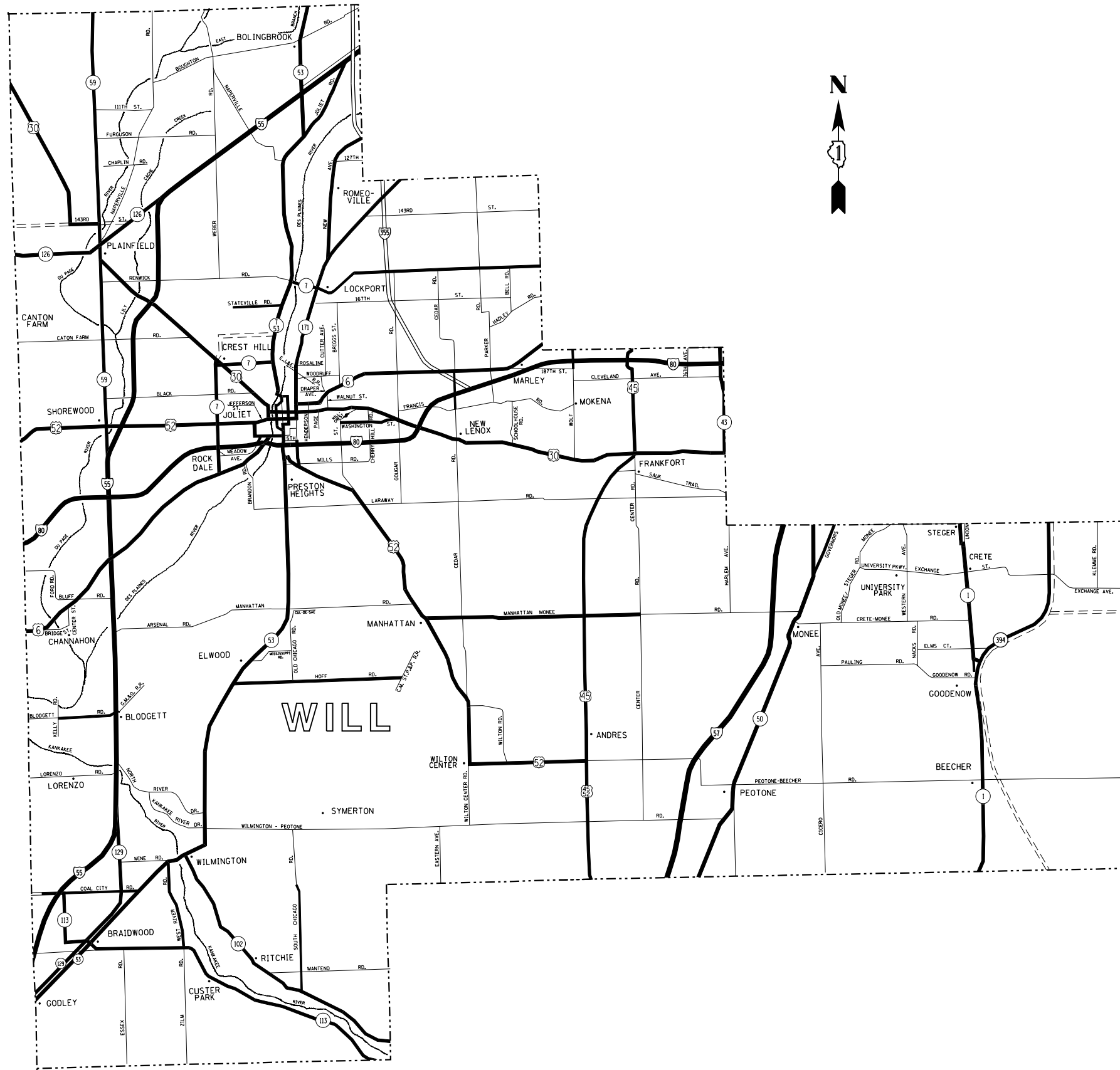
FILE NAME =	USER NAME = midyja	DESIGNED -	REVISED -
p:\planroom\dot.illinois.gov\PIDOT\Documents\IDOT Offices\District 1\Projects\0144815\Drawn\Design\0144816-sht-plan.dgn		DRAWN -	REVISED -
Default	PLOT SCALE = 100.0000' / in.	CHECKED -	REVISED -
	PLOT DATE = 12/7/2019	DATE -	REVISED -

STATE OF ILLINOIS  
DEPARTMENT OF TRANSPORTATION

FENCE REPAIR LOCATION MAP - KANE COUNTY  
SOUTH OF IL RTE 38

SCALE: SHEET OF SHEETS STA. TO STA.

F.A. RTE.	SECTION	COUNTY	TOTAL SHEETS	SHEET NO.
VAR	2019-138-1	VARIOUS	21	6
			CONTRACT NO. 62K12	
ILLINOIS FED. AID PROJECT				



## DISTRICT NO. 1 MAINTENANCE DESIGNATIONS

- VARIOUS COLORS STATE HIGHWAYS & EXPRESSWAYS
- TOLLWAY
- CITY MAINTENANCE AGREEMENTS
- FUTURE HIGHWAYS
- VARIOUS AGENCIES HIGHWAYS

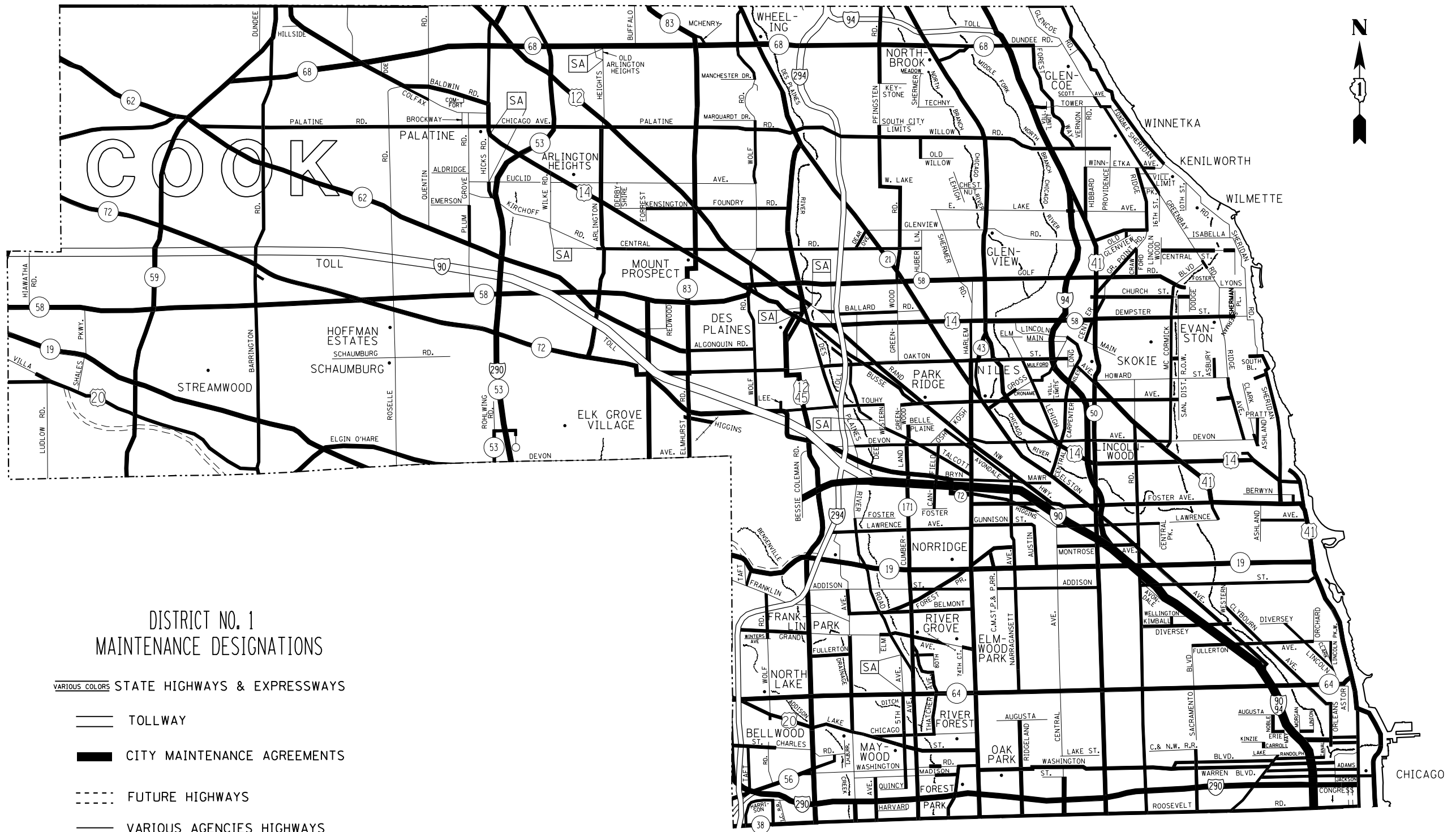
FILE NAME =	USER NAME = midyja	DESIGNED -	REVISED -
pw:\planroom.dot.illinois.gov\PIDOT\Documents\IDOT Offices\District 1\Projects\0144816\Drawn\Design\0144816-sht-plan.dgn		DRAWN -	REVISED -
Default	PLOT SCALE = 100.0000' / 1" =	CHECKED -	REVISED -
	PLOT DATE = 12/7/2019	DATE -	REVISED -

**STATE OF ILLINOIS  
DEPARTMENT OF TRANSPORTATION**

**FENCE REPAIR LOCATION MAP - WILL COUNTY**

SCALE:      SHEET      OF      SHEETS      STA.      TO      STA.

F.A. RTE.	SECTION	COUNTY	TOTAL SHEETS	SHEET NO.
VAR	2019-138-1	VARIOUS	21	7
CONTRACT NO. 62K12				
ILLINOIS FED. AID PROJECT				



DISTRICT NO. 1  
MAINTENANCE DESIGNATIONS

VARIOUS COLORS STATE HIGHWAYS & EXPRESSWAYS

— TOLLWAY

— CITY MAINTENANCE AGREEMENTS

- - - FUTURE HIGHWAYS

— VARIOUS AGENCIES HIGHWAYS

FILE NAME =	USER NAME = midyja	DESIGNED -	REVISED -
pw:\planroom.dot.illinois.gov\PIDOT\Documents\IDOT Offices\District 1\Projects\0144816\Drawn\Design\0144816-sht-plan.dgn		DRAWN -	REVISED -
Default	PLOT SCALE = 100.0000' / in.	CHECKED -	REVISED -
	DATE = 12/7/2019	DATE -	REVISED -

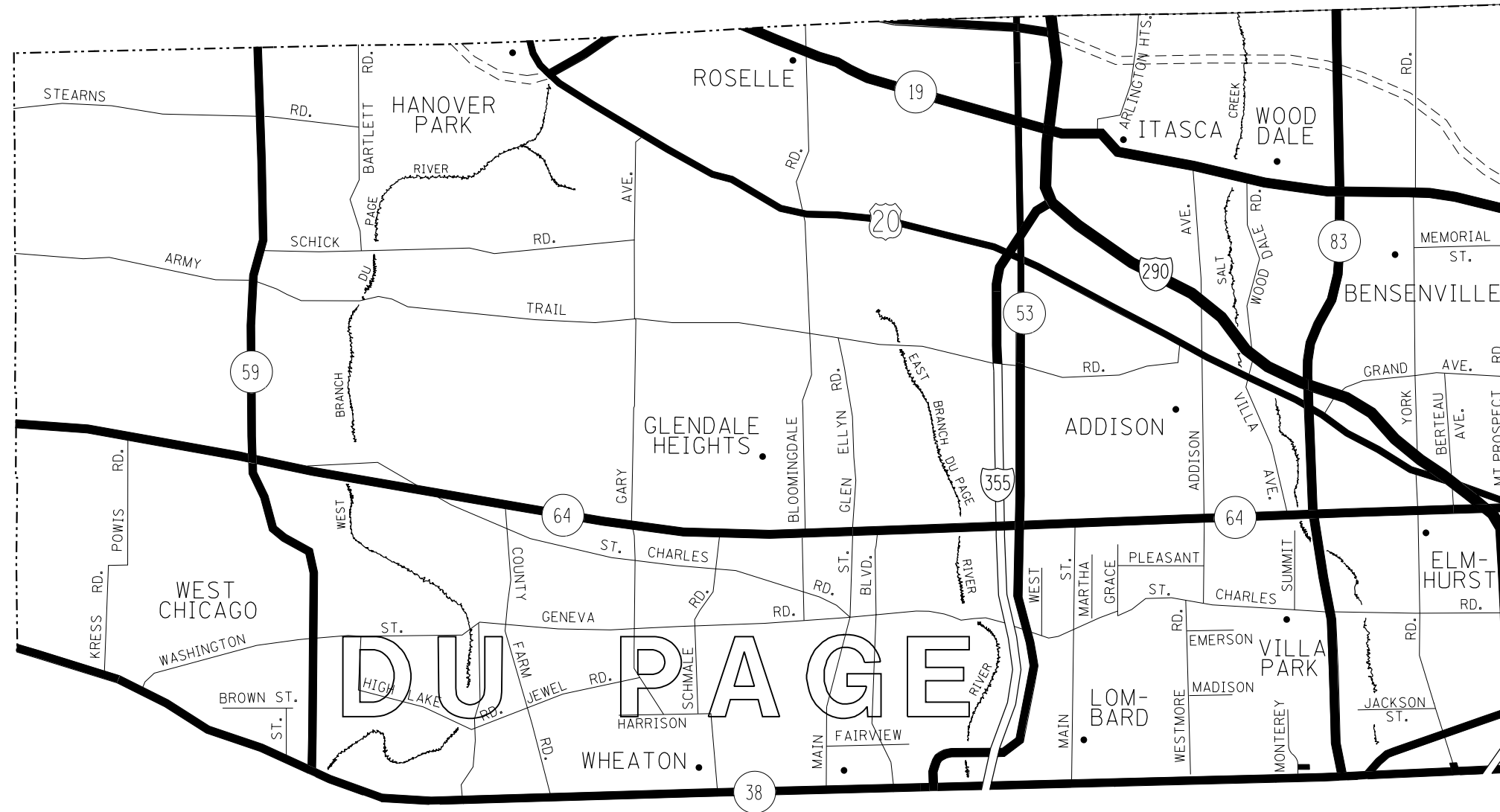
STATE OF ILLINOIS  
DEPARTMENT OF TRANSPORTATION

FENCE REPAIR LOCATION MAP - COOK COUNTY  
NORTH OF IL RTE 38

SCALE: SHEET OF SHEETS STA. TO STA.

F.A. RTE.	SECTION	COUNTY	TOTAL SHEETS	SHEET NO.
VAR	2019-138-1	VARIOUS	21	8
			CONTRACT NO. 62K12	
ILLINOIS FED. AID PROJECT				

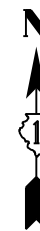
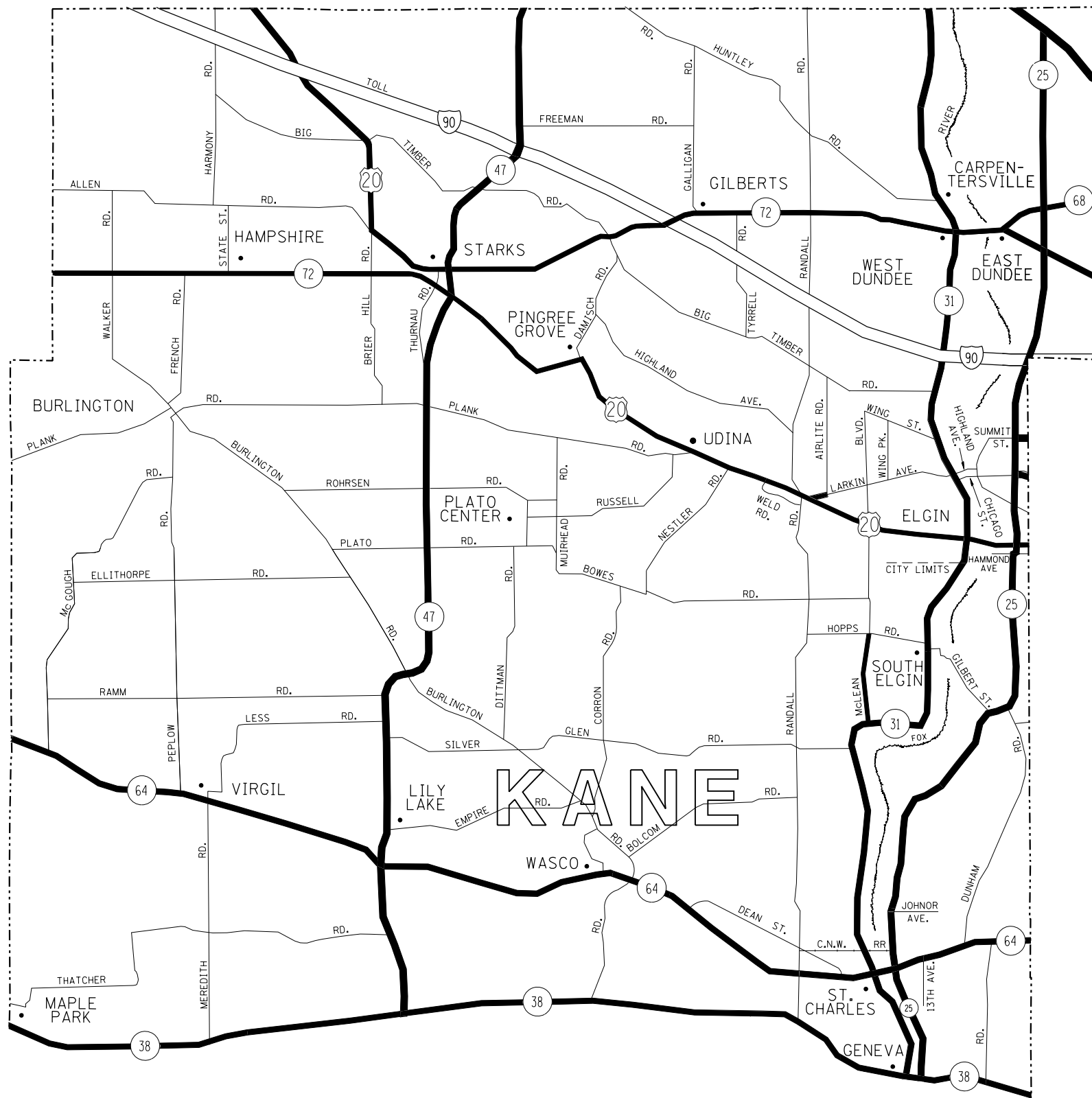




DISTRICT NO. 1  
MAINTENANCE DESIGNATIONS

- VARIOUS COLORS STATE HIGHWAYS & EXPRESSWAYS
- TOLLWAY
- CITY MAINTENANCE AGREEMENTS
- FUTURE HIGHWAYS
- VARIOUS AGENCIES HIGHWAYS

FILE NAME =	USER NAME = midyja	DESIGNED -	REVISED -	<b>STATE OF ILLINOIS DEPARTMENT OF TRANSPORTATION</b>	<b>FENCE REPAIR LOCATION MAP - DuPAGE COUNTY NORTH OF IL RTE 38</b>	F.A. RTE.	SECTION	COUNTY	TOTAL SHEETS	SHEET NO.
pw:\planroom.dot.illinois.gov\PIDOT\Documents\IDOT Offices\District 1\Projects\0144816\Drawn\Design\0144816-sht-plan.dgn		DRAWN -	REVISED -			VAR	2019-138-1	VARIOUS	21	9
Default		PLOT SCALE = 100.0000' / in.	CHECKED -			REVISED -	CONTRACT NO. 62K12			ILLINOIS FED. AID PROJECT
		PLOT DATE = 12/7/2019	DATE -	REVISED -	SCALE:	SHEET	OF	SHEETS	STA.	TO STA.



DISTRICT NO. 1  
MAINTENANCE DESIGNATIONS

- VARIOUS COLORS STATE HIGHWAYS & EXPRESSWAYS
- TOLLWAY
- CITY MAINTENANCE AGREEMENTS
- FUTURE HIGHWAYS
- VARIOUS AGENCIES HIGHWAYS

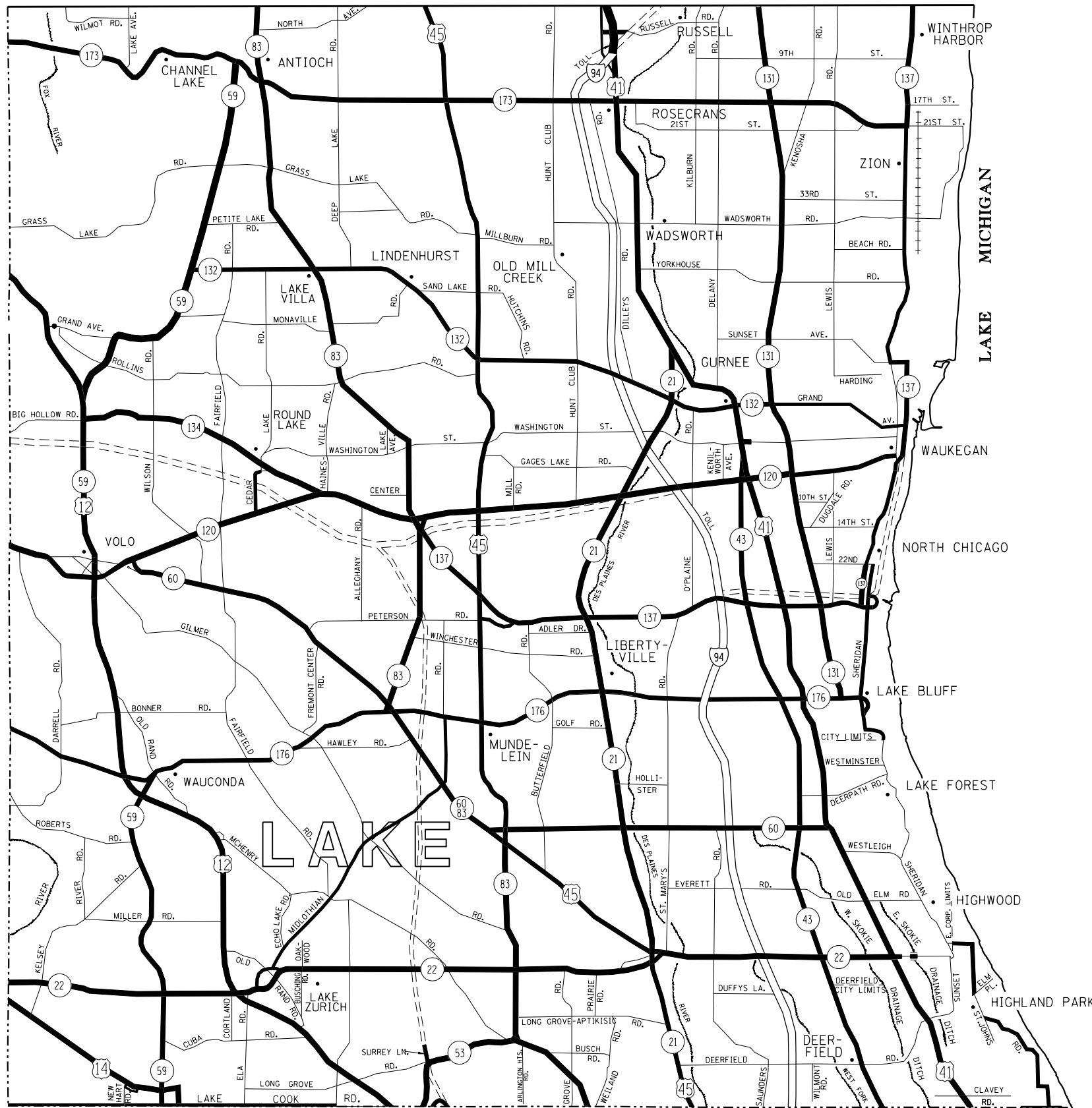
FILE NAME =	USER NAME = midyja	DESIGNED -	REVISED -
p:\planroom\dot.illinois.gov\PIDOT\Documents\IDOT Offices\District 1\Projects\0144816\Design\0144816-sht-plan.dgn		DRAWN -	REVISED -
Default	PLOT SCALE = 100.0000' / in.	CHECKED -	REVISED -
	PLOT DATE = 12/7/2019	DATE -	REVISED -

STATE OF ILLINOIS  
DEPARTMENT OF TRANSPORTATION

FENCE REPAIR LOCATION MAP - KANE COUNTY  
NORTH OF IL RTE 38

SCALE: SHEET OF SHEETS STA. TO STA.

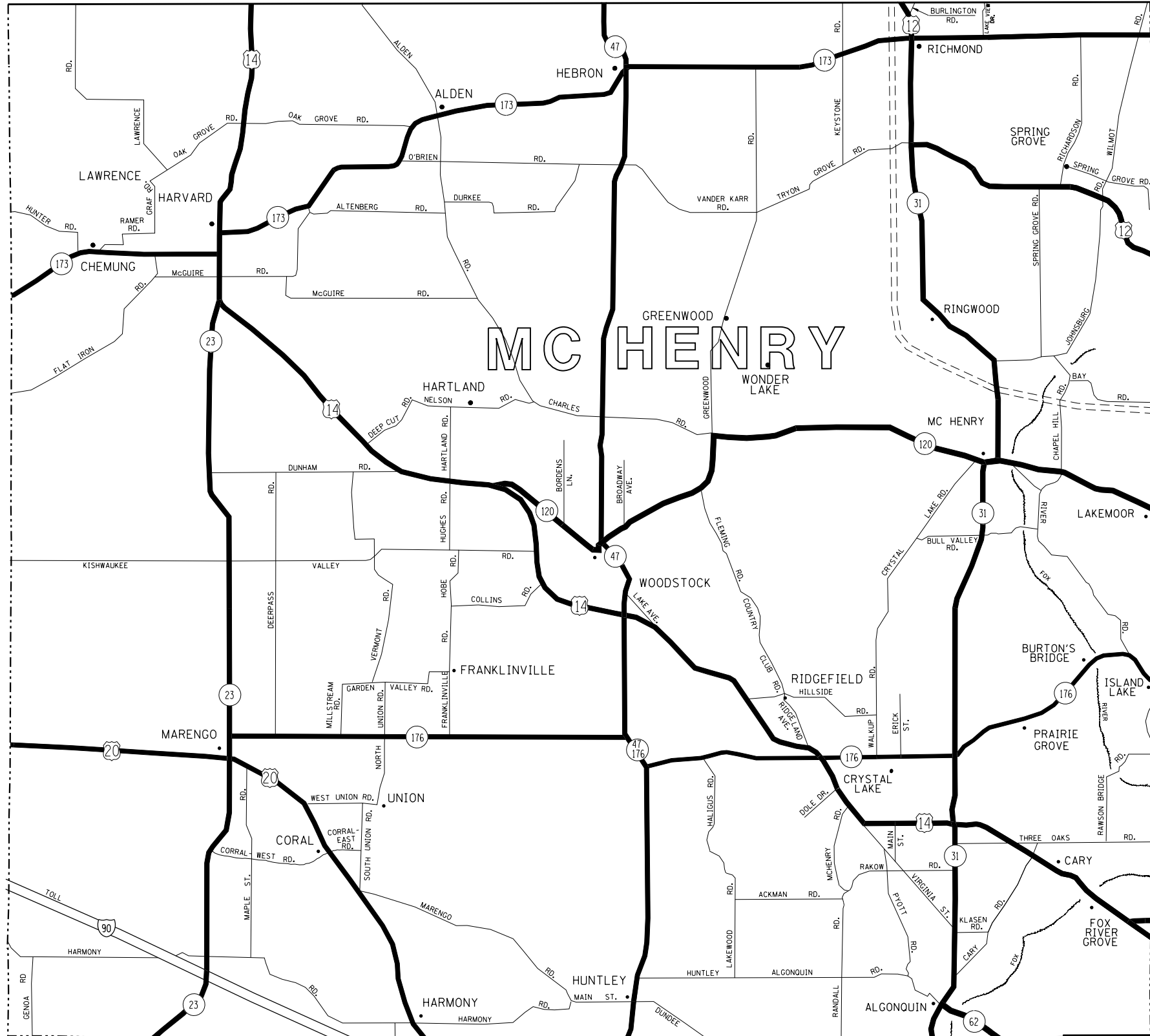
F.A. RTE.	SECTION	COUNTY	TOTAL SHEETS	SHEET NO.
VAR	2019-138-1	VARIOUS	21	10
			CONTRACT NO. 62K12	
ILLINOIS FED. AID PROJECT				



### DISTRICT NO. 1 MAINTENANCE DESIGNATIONS

- VARIOUS COLORS STATE HIGHWAYS & EXPRESSWAYS
- TOLLWAY
- CITY MAINTENANCE AGREEMENTS
- FUTURE HIGHWAYS
- VARIOUS AGENCIES HIGHWAYS

FILE NAME =	USER NAME = midyja	DESIGNED -	REVISED -	<b>STATE OF ILLINOIS DEPARTMENT OF TRANSPORTATION</b>	<b>FENCE REPAIR LOCATION MAP - LAKE COUNTY</b>	F.A. RTE.	SECTION	COUNTY	TOTAL SHEETS	SHEET NO.	
pw:\planroom.dot.illinois.gov\PWIDOT\Documents\IDOT Offices\District 1\Projects\0144816\0144816.dgn		DRW				VAR	2019-138-1	VARIOUS	21	11	
Default	PLOT SCALE = 100.0000' / in.	CHECKED -	REVISED -			CONTRACT NO. 62K12					
	PLOT DATE = 12/7/2019	DATE -	REVISED -			SCALE:		SHEET OF SHEETS STA. TO STA.			
ILLINOIS FED. AID PROJECT											



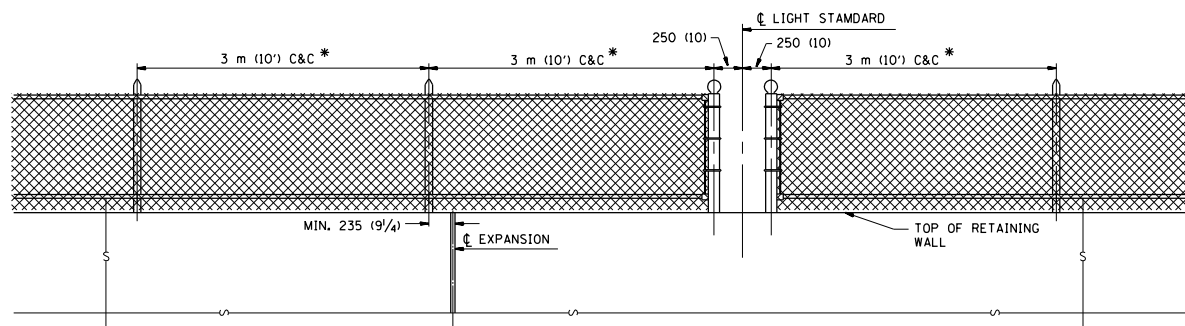
### DISTRICT NO. 1 MAINTENANCE DESIGNATIONS

- VARIOUS COLORS STATE HIGHWAYS & EXPRESSWAYS
- TOLLWAY
- CITY MAINTENANCE AGREEMENTS
- - - FUTURE HIGHWAYS
- VARIOUS AGENCIES HIGHWAYS

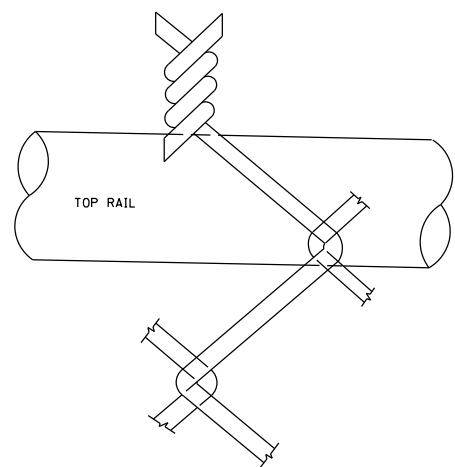
FILE NAME =	USER NAME = miduja	DESIGNED -	REVISED -	<b>STATE OF ILLINOIS DEPARTMENT OF TRANSPORTATION</b>	<b>GUARDRAIL REPAIR LOCATION MAP McHENRY COUNTY</b>	F.A. RTE.	SECTION	COUNTY	TOTAL SHEETS	SHEET NO.
p:\planroom\dot.illinois.gov\PWIDOT\Documents\IDOT Offices\District 1\Projects\0144815\Drawn\Design\0144816-sht-plan.dgn		CHECKED -	REVISED -			VAR.	2019-138-1	VARIOUS	21	12
PLOT SCALE = 100.0000' / in.		DATE -	REVISED -			CONTRACT NO. 62K12				
PLOT DATE = 12/7/2019						FED. ROAD DIST. NO.	ILLINOIS	FED. AID PROJECT		
SCALE:						SHEET NO.	OF SHEETS	STA.	TO STA.	

**NOTE**

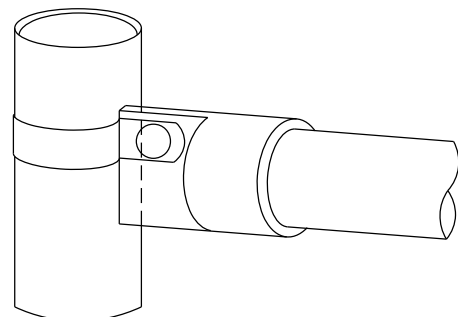
\* MAXIMUM POST SPACING SHALL BE 3 m (10') C&C EXCEPT WHERE OTHERWISE SHOWN ON PLANS



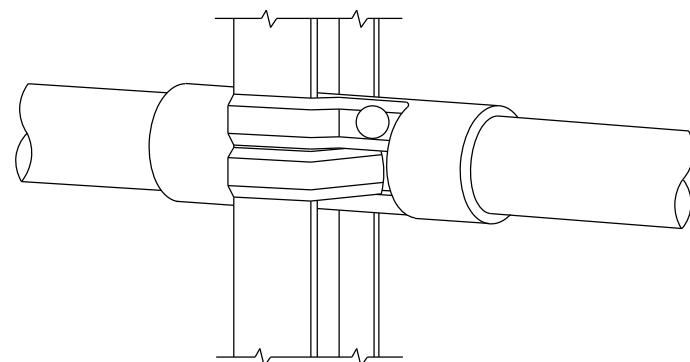
**ELEVATION VIEW OF RETAINING WALL WITH PEDESTRIAN BARRIER TYPE III**



**WIRE MESH FABRIC TO BE BARBED AT THE TOP**

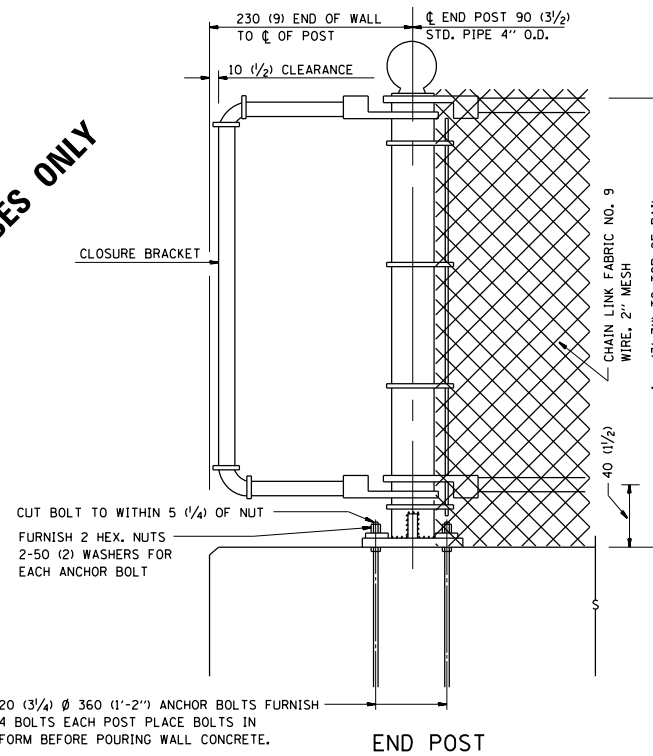


**RAIL FITTING AT END POSTS**



**RAIL FITTING ON SECTION LINE POST**

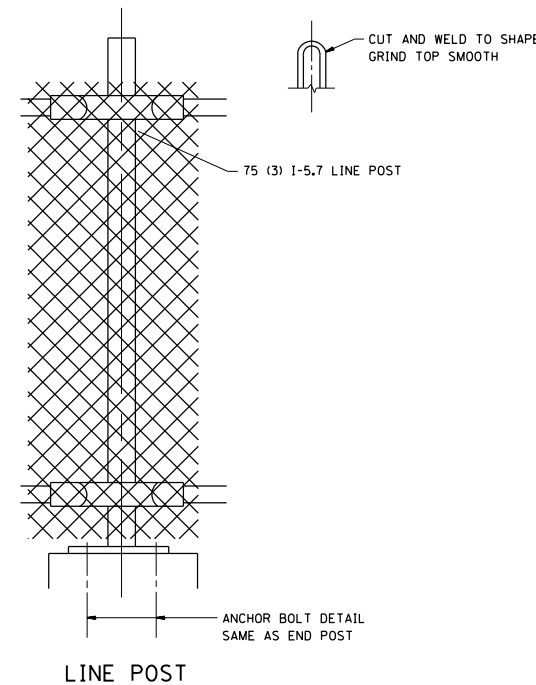
**FOR INFORMATIONAL PURPOSES ONLY**



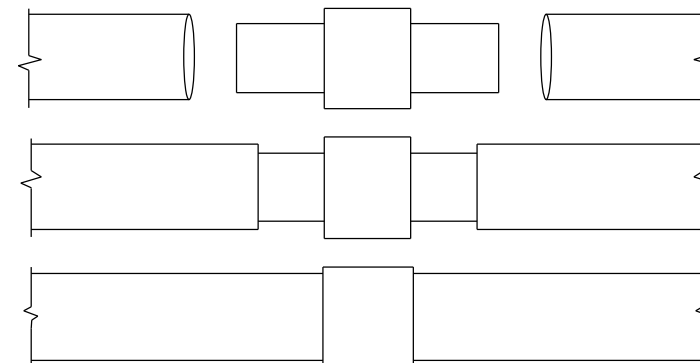
**END POST**

20 (3/4) Ø 360 (1'-2") ANCHOR BOLTS FURNISH 4 BOLTS EACH POST PLACE BOLTS IN FORM BEFORE POURING WALL CONCRETE.

**NOTE:**  
THE COST OF FURNISHING ANCHOR BOLTS, NUTS, & WASHERS TO BE INCIDENTAL

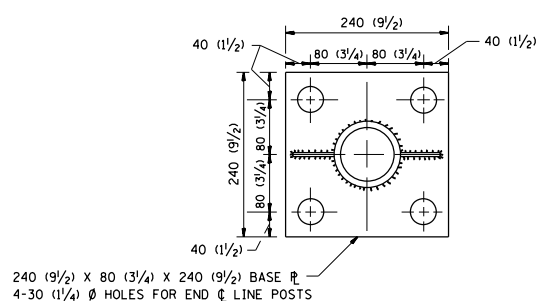


**LINE POST**



**EXPANSION COUPLING DETAIL**

**NOTE:**  
EXP. COUPLING TO APPEAR IN TOP AND BOTTOM RAILS WHERE EVER EXP. JT. APPEARS IN STRUCTURE.

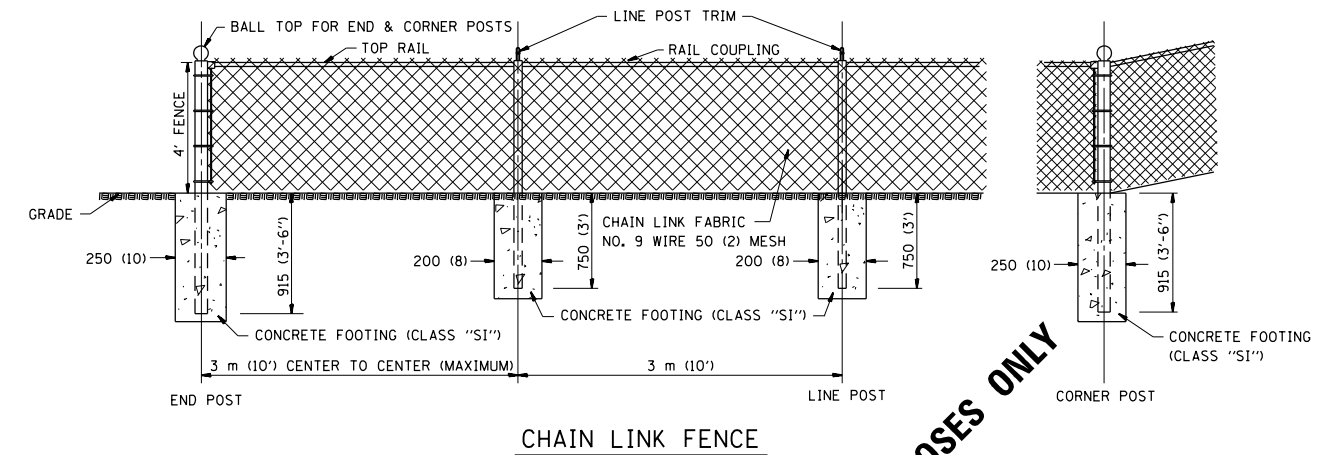


**ANCHOR PLATE DETAILS**

**NOTE:**  
POST, PLATE AND GUSSET ASSEMBLY SHALL BE GALVANIZED AFTER ALL CUTTING, DRILLING, WELDING, AND FABRICATION HAVE BEEN COMPLETED. THE GALVANIZED COATING SHALL CONFORM TO THE REQUIREMENTS OF AASHTO M 120. THE GALVANIZED COATING SHALL NOT BE LESS THAN 610 G/SQ M (2.0 OZ./SQ. FT.) OF SURFACE.

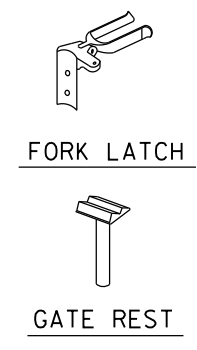
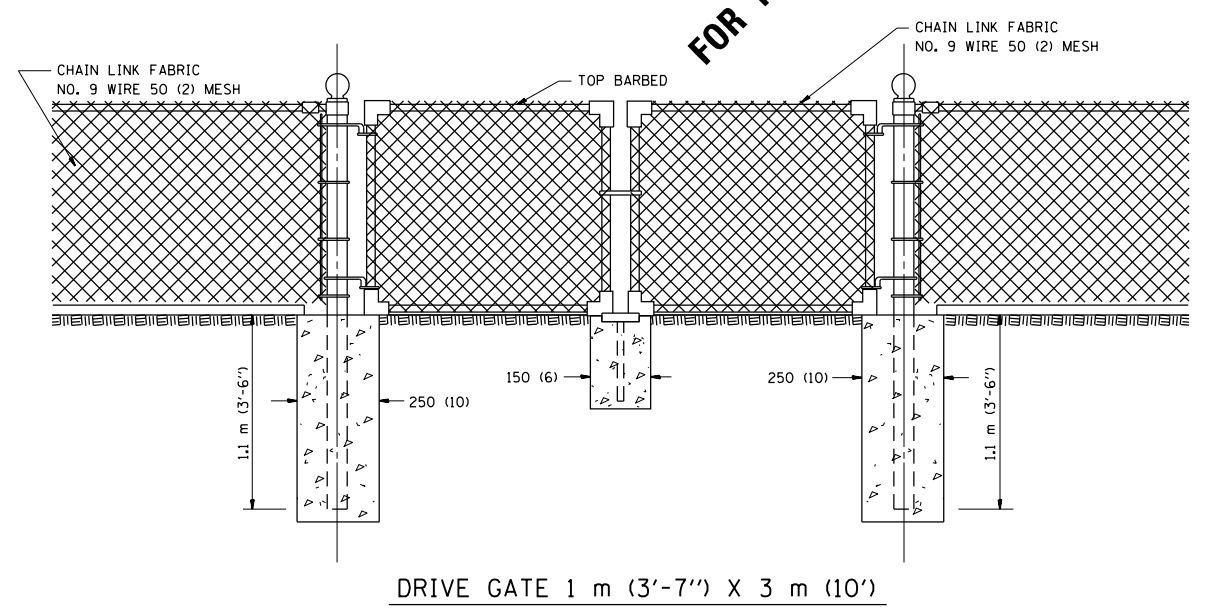
ALL DIMENSIONS ARE IN MILLIMETERS (INCHES) UNLESS OTHERWISE SHOWN.

FILE NAME =	USER NAME = miduja	DESIGNED -	REVISED -	<b>STATE OF ILLINOIS DEPARTMENT OF TRANSPORTATION</b>	<b>PEDESTRIAN BARRIER TYPE III STD. 10-SS-514 R</b>	F.A. RTÉ.	SECTION	COUNTY	TOTAL SHEETS	SHEET NO.
pw:\planroom.dot.illinois.gov\PIDOT\Documents\IDOT Offices\District 1\Projects\0144815\Drawn\Design\0144816-sht-plan.dgn	PLOT SCALE = 100.0000' / 1in.	CHECKED -	REVISED -			VAR	2019-138-1	VARIOUS	21	13
PLOT DATE = 12/7/2019	DATE -	REVISED -	REVISED -			CONTRACT NO. 62K12				
						FED. ROAD DIST. NO.	ILLINOIS	FED. AID PROJECT		



CHAIN LINK FENCE

FOR INFORMATIONAL PURPOSES ONLY



ALL DIMENSIONS ARE IN MILLIMETERS (INCHES) UNLESS OTHERWISE SHOWN.

NOTE:  
 THE CHAIN LINK FENCE AS SHOWN HEREIN SHALL BE CONSTRUCTED AT SUCH LOCATIONS AS SHOWN ON PLANS AND IN ACCORDANCE WITH THE SPECIAL PROVISIONS  
  
 THE ENGINEER SHALL ESTABLISH ALL NECESSARY LINE AND GRADE PRIOR TO THE ERECTION OF THE FENCE IN CONFORMANCE WITH THE PLANS

FILE NAME =	USER NAME = midyja	DESIGNED -	REVISED -
p:\planroom.dot.illinois.gov\PIDOT\Documents\IDOT Offices\District 1\Projects\0144815\DRAWING\Design\0144816-sht-plan.dgn		DRAWN -	REVISED -
	PLOT SCALE = 100.0000' / 1m.	CHECKED -	REVISED -
	PLOT DATE = 12/7/2019	DATE -	REVISED -

STATE OF ILLINOIS  
 DEPARTMENT OF TRANSPORTATION

CHAIN LINK FENCE  
 STD. 10-SS-506 B

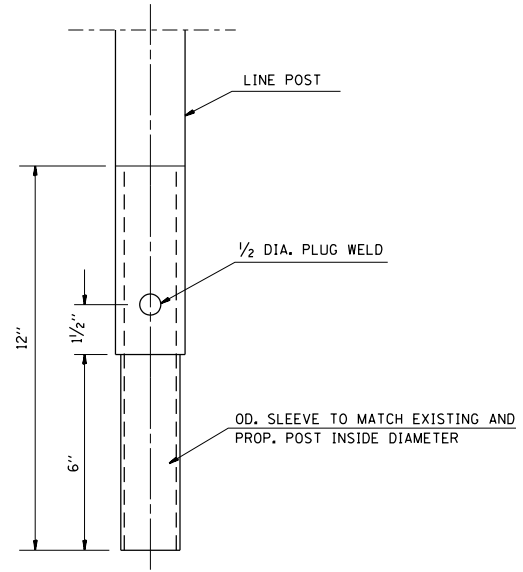
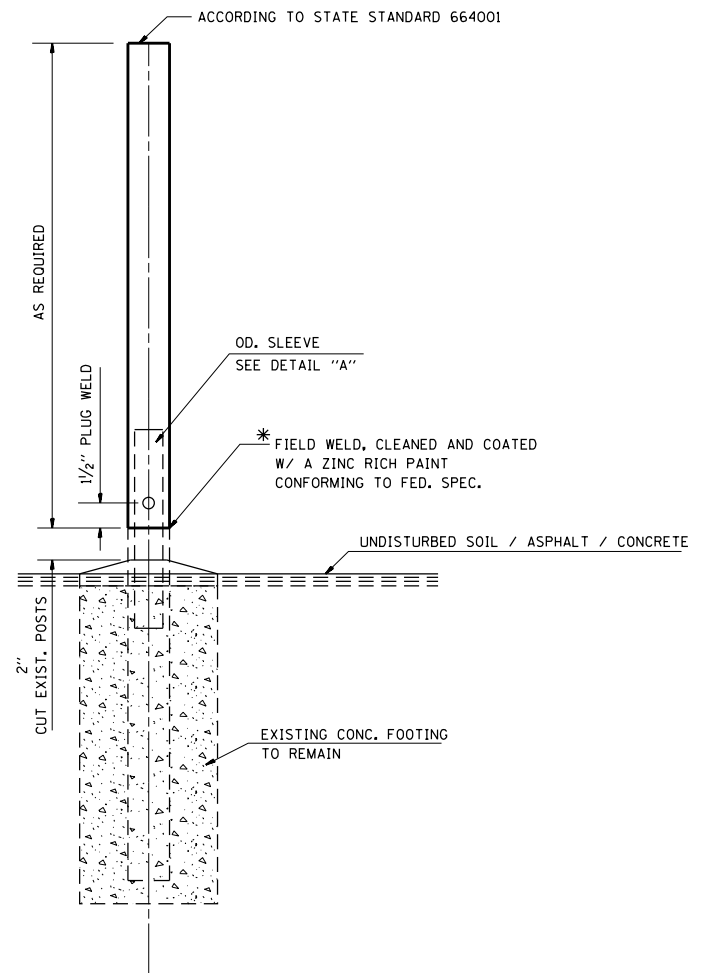
SCALE:	SHEET NO.	OF SHEETS	STA.	TO STA.
--------	-----------	-----------	------	---------

F.A. RTE.	SECTION	COUNTY	TOTAL SHEETS	SHEET NO.
VAR	2019-138-1	VARIOUS	21	14
FED. ROAD DIST. NO.			ILLINOIS FED. AID PROJECT	
			CONTRACT NO. 62K12	

GENERAL NOTES:

THIS WORK CONSISTS OF FURNISHING ALL LABOR, MATERIALS, TOOLS AND EQUIPMENT TO REPAIR CHAIN LINK FENCE POST SLEEVE AS SHOWN ON THE PLANS OR AS DIRECTED BY THE ENGINEER, AND IN ACCORDANCE WITH STATE STANDARD 664001.

BASIS OF PAVEMENT: THIS WORK SHALL BE PAID FOR AT THE CONTRACT UNIT PRICE EACH FOR "CHAIN LINK FENCE POST SLEEVE REPAIR" WHICH PRICE SHALL BE PAYMENT IN FULL TO COMPLETE THE WORK AS SPECIFIED HEREIN.



SLEEVE DET. DWG  
DETAIL "A"  
SLEEVE DETAIL

\* THIS WORK SHALL BE INCLUDED IN THE COST OF THE PAY ITEM "CHAIN LINK FENCE POST SLEEVE REPAIR"

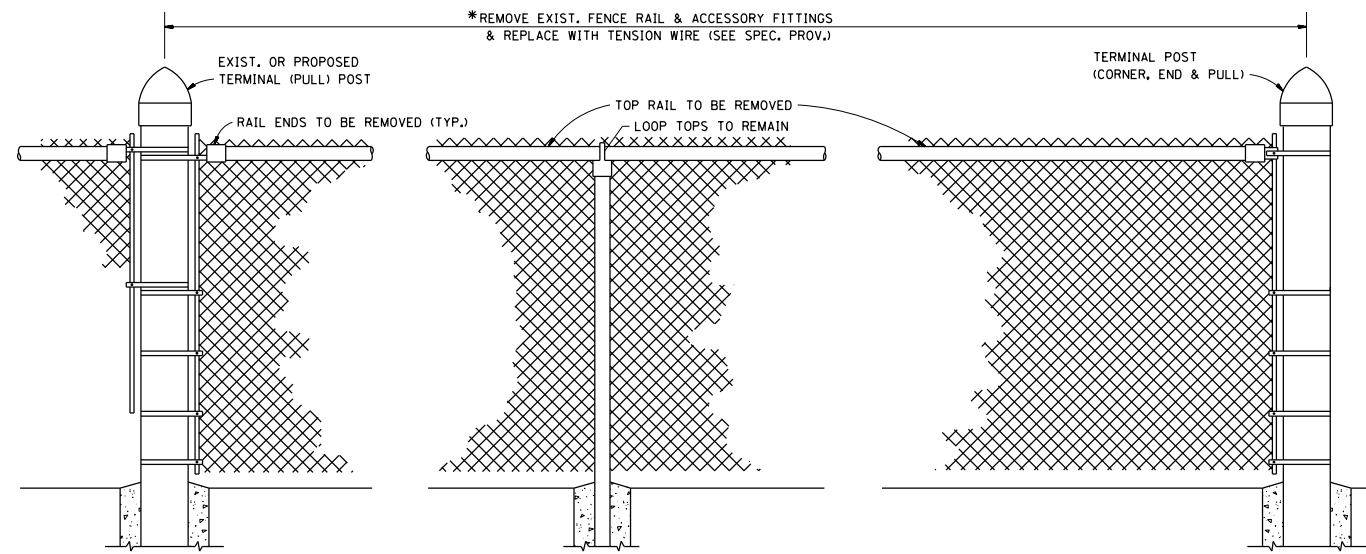
FILE NAME =	USER NAME = midyja	DESIGNED -	REVISED -
p:\planroom\dot.illinois.gov\PIDOT\Documents\IDOT Offices\District 1\Projects\0144815\DRAWING\Design\0144816-sht-plan.dgn		DRAWN -	REVISED -
PLOT SCALE = 100.0000' / 1in.	CHECKED -	REVISED -	REVISED -
PLOT DATE = 12/7/2019	DATE -	REVISED -	REVISED -

STATE OF ILLINOIS  
DEPARTMENT OF TRANSPORTATION

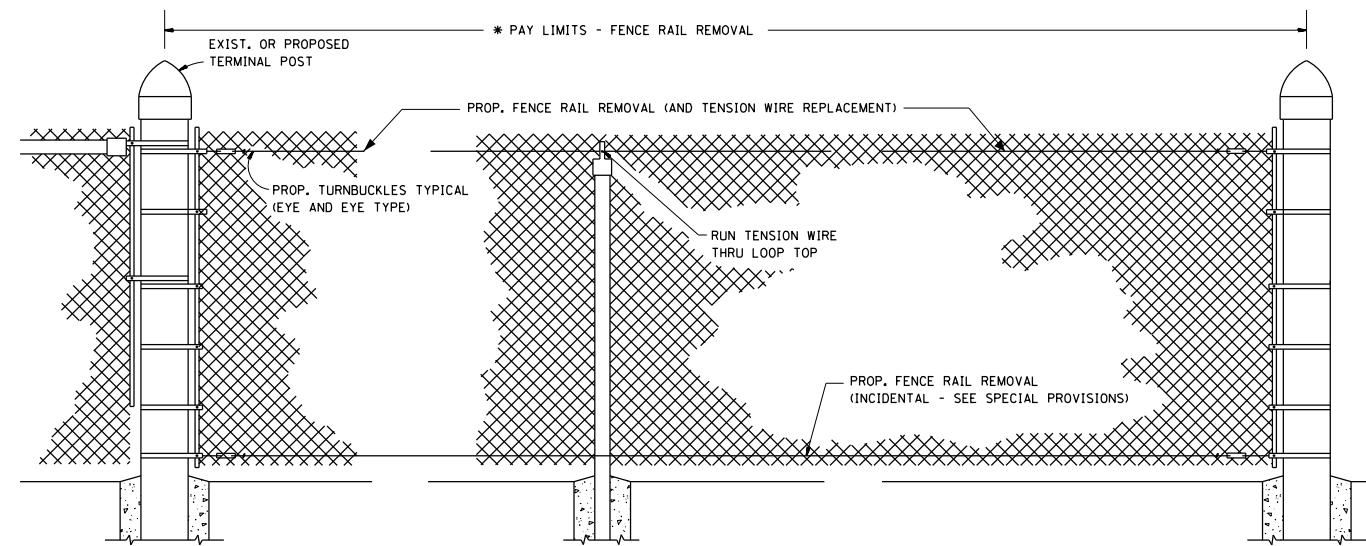
CHAIN LINK FENCE POST SLEEVE  
REPAIR DETAIL

SCALE: SHEET NO. OF SHEETS STA. TO STA.

F.A. RTE.	SECTION	COUNTY	TOTAL SHEETS	SHEET NO.
VAR	2019-138-1	VARIOUS	21	15
FED. ROAD DIST. NO.			ILLINOIS FED. AID PROJECT	
			CONTRACT NO. 62K12	



EXIST. CHAIN LINK FENCE WITH TOP RAIL



PROP. CHAIN LINK FENCE WITH "FENCE RAIL REMOVAL"

\* THE ENGINEER IN CHARGE SHALL DETERMINE THE LENGTH OF FENCE RAIL TO BE REMOVED & REPLACED WITH "TENSION WIRE"

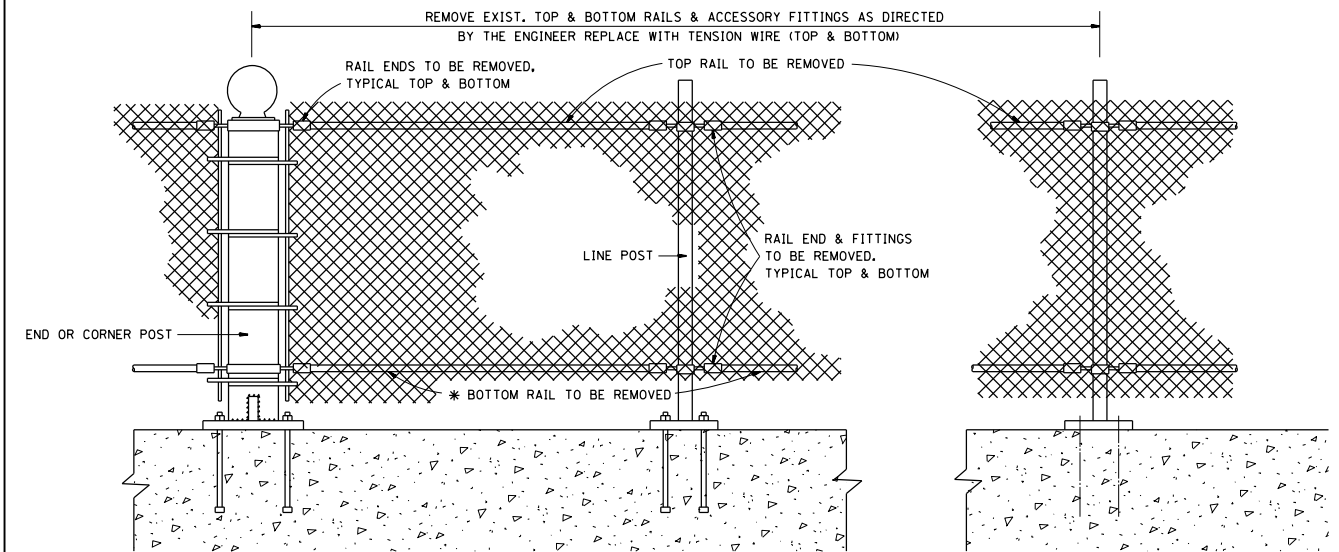
**GENERAL NOTES**

**FENCE RAIL REMOVAL:** THIS ITEM CONSISTS OF REMOVING EXISTING TOP OR BOTTOM RAIL, (DAMAGED OR UNDAMAGED) AND REPLACING WITH TENSION WIRE. BOTTOM TENSION WIRE SHALL BE CONSIDERED INCIDENTAL EXCEPT AT LOCATIONS OF EXISTING BOTTOM RAIL REMOVAL.

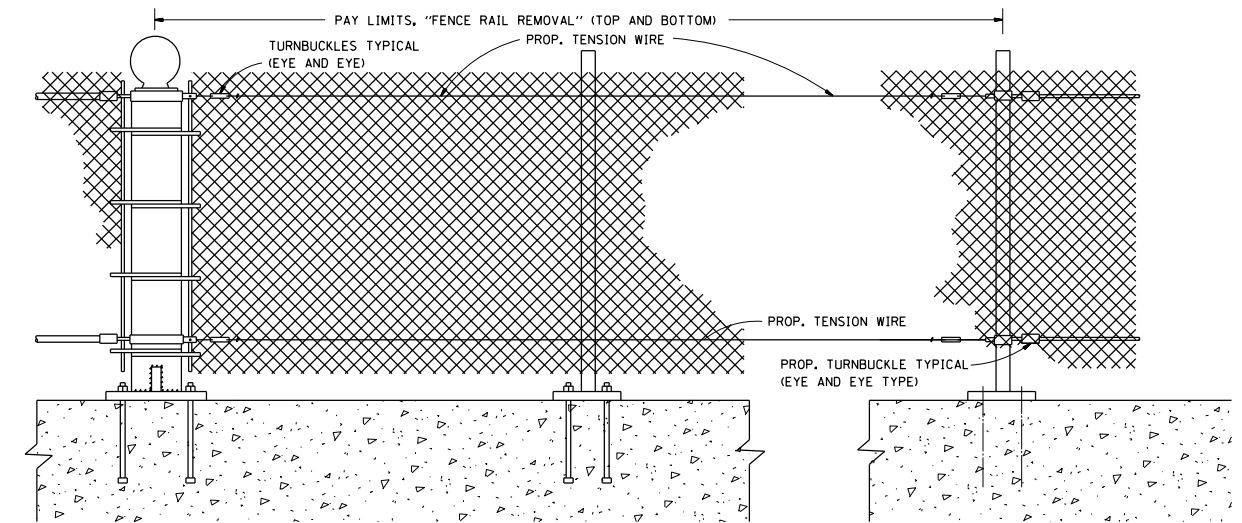
**TENSION WIRE:** THIS ITEM CONSISTS OF INSTALLING TENSION WIRE, TOP OR BOTTOM, WHERE TOP OR BOTTOM RAIL IS NON-EXISTENT, OR WHERE EXISTING DAMAGED TENSION WIRE IS REMOVED AND REPLACED BY NEW TENSION WIRE.

ALL WORK AND MATERIALS SHALL BE IN ACCORDANCE WITH THE PLANS, SPECIAL PROVISIONS, STANDARD SPECIFICATIONS AND STANDARD 664001.

REPLACEMENT OF OTHER FENCE COMPONENT PARTS SHALL BE MEASURED AND PAID FOR SEPARATELY AS DESCRIBED IN THE SPECIAL PROVISIONS.



EXIST. PEDESTRIAN BARRIER TYPE 3 WITH TOP AND BOTTOM RAILS



PROP. PEDESTRIAN BARRIER TYPE 3 WITH FENCE RAIL REMOVAL

ALL DIMENSIONS ARE IN MILLIMETERS (INCHES) UNLESS OTHERWISE SHOWN.

FILE NAME =	USER NAME = midyja	DESIGNED -	REVISED -
pw:\planroom.dot.illinois.gov\PIDOT\Documents\IDOT Offices\District 1\Projects\0144815\Drawn\Design\0144816-sht-plan.dgn		DRAWN -	REVISED -
	PLOT SCALE = 100.0000' / 1in.	CHECKED -	REVISED -
	PLOT DATE = 12/7/2019	DATE -	REVISED -

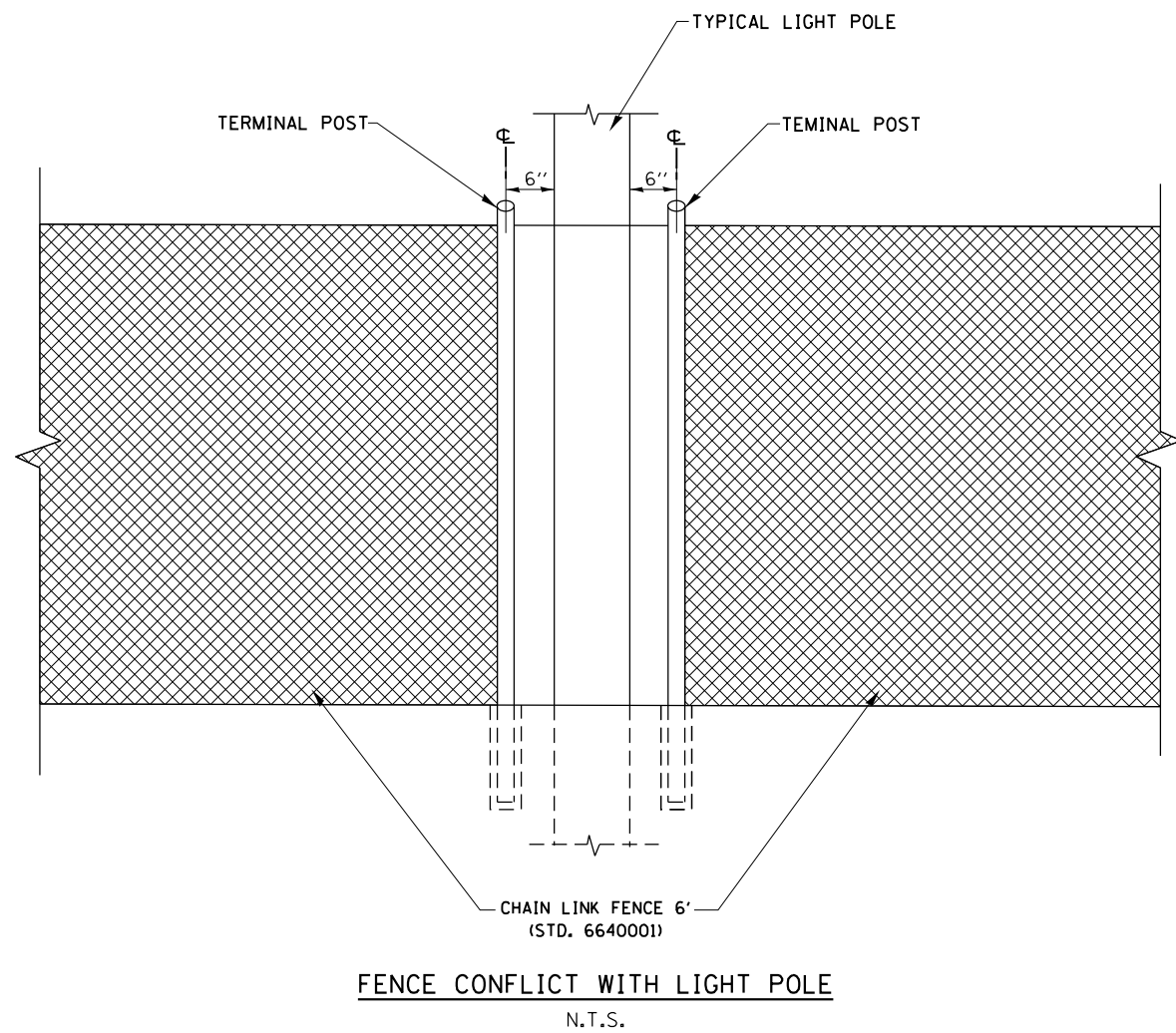
**STATE OF ILLINOIS  
DEPARTMENT OF TRANSPORTATION**

**PROPOSED PEDESTRIAN BARRIER AND  
CHAIN LINK FENCE WITH TENSION WIRE AND FENCE RAIL REMOVAL**

SCALE: SHEET NO. OF SHEETS STA. TO STA.

F.A. RTE.	SECTION	COUNTY	TOTAL SHEETS	SHEET NO.
VAR	2019-138-1	VARIOUS	21	16
CONTRACT NO. 62K12				
FED. ROAD DIST. NO. ILLINOIS FED. AID PROJECT				

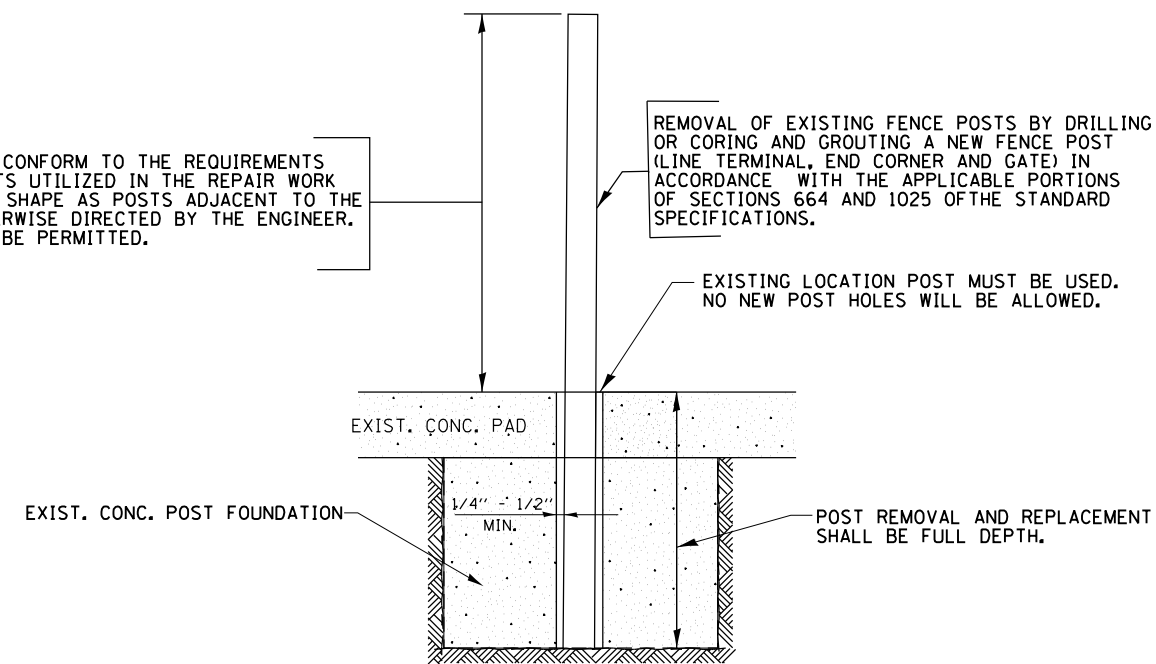




GALVANIZED POSTS SHALL CONFORM TO THE REQUIREMENTS OF STANDARD 864001 POSTS UTILIZED IN THE REPAIR WORK SHALL BE THE SAME TYPE SHAPE AS POSTS ADJACENT TO THE REPAIR AREA UNLESS OTHERWISE DIRECTED BY THE ENGINEER. NO USED MATERIALS WILL BE PERMITTED.

REMOVAL OF EXISTING FENCE POSTS BY DRILLING OR CORING AND GROUTING A NEW FENCE POST (LINE TERMINAL, END CORNER AND GATE) IN ACCORDANCE WITH THE APPLICABLE PORTIONS OF SECTIONS 664 AND 1025 OF THE STANDARD SPECIFICATIONS.

EXISTING LOCATION POST MUST BE USED. NO NEW POST HOLES WILL BE ALLOWED.



**POST REMOVAL AND REPLACEMENT**

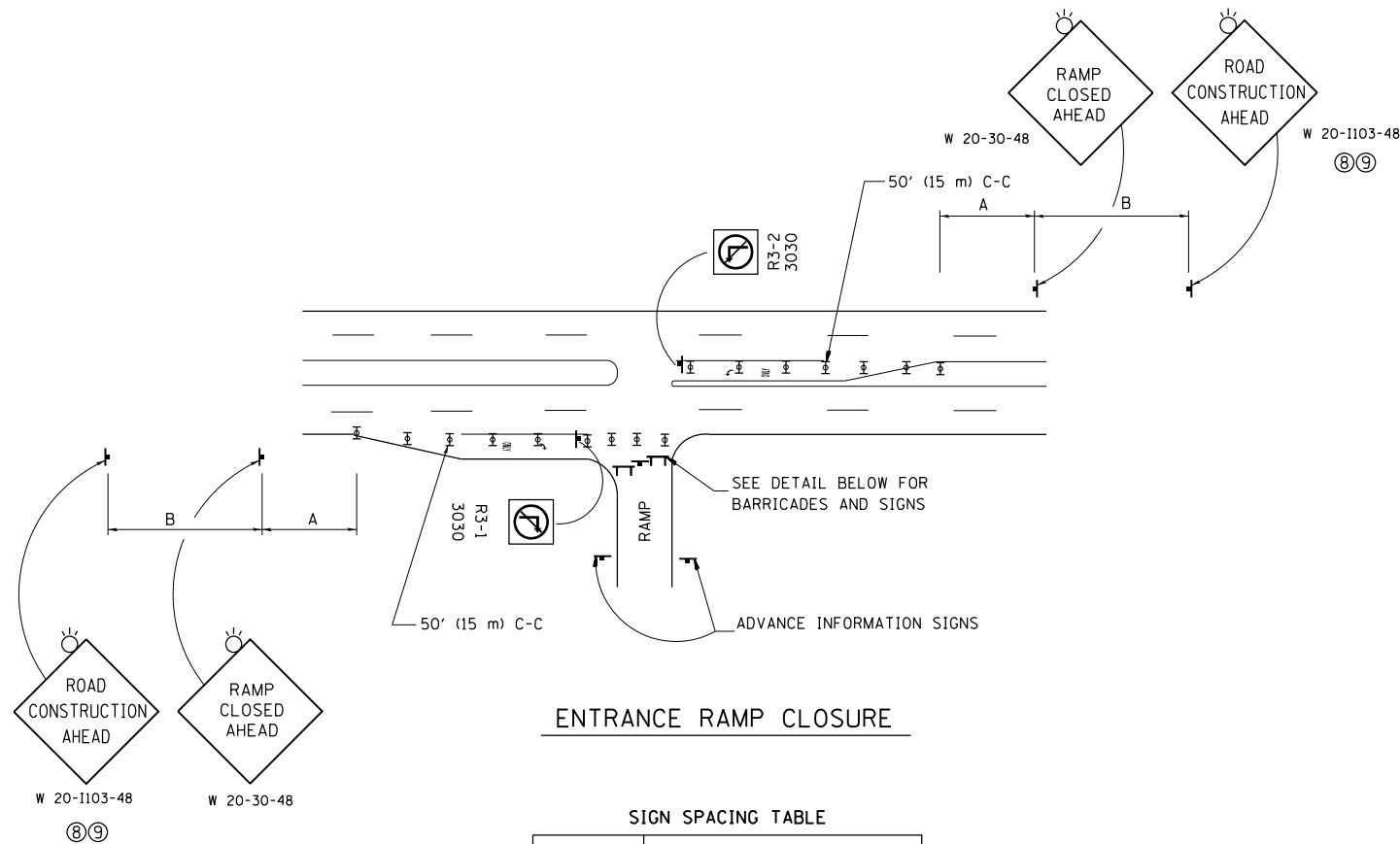
FILE NAME =	USER NAME = midyja	DESIGNED -	REVISED -
p:\planroom.dot.illinois.gov\PWIDOT\Documents\IDOT Offices\District 1\Projects\0144816\DRAWING\Design\0144816-sht-plan.dgn		DRAWN -	REVISED -
Default	PLOT SCALE = 100.0000' / 1in.	CHECKED -	REVISED -
	PLOT DATE = 12/7/2019	DATE -	REVISED -

**STATE OF ILLINOIS  
DEPARTMENT OF TRANSPORTATION**

**SPECIAL FENCE DETAILS**

SCALE: SHEET OF SHEETS STA. TO STA.

F.A. RTE.	SECTION	COUNTY	TOTAL SHEETS	SHEET NO.
VAR	2019-138-1	VARIOUS	21	17
			CONTRACT NO. 62K12	
ILLINOIS FED. AID PROJECT				

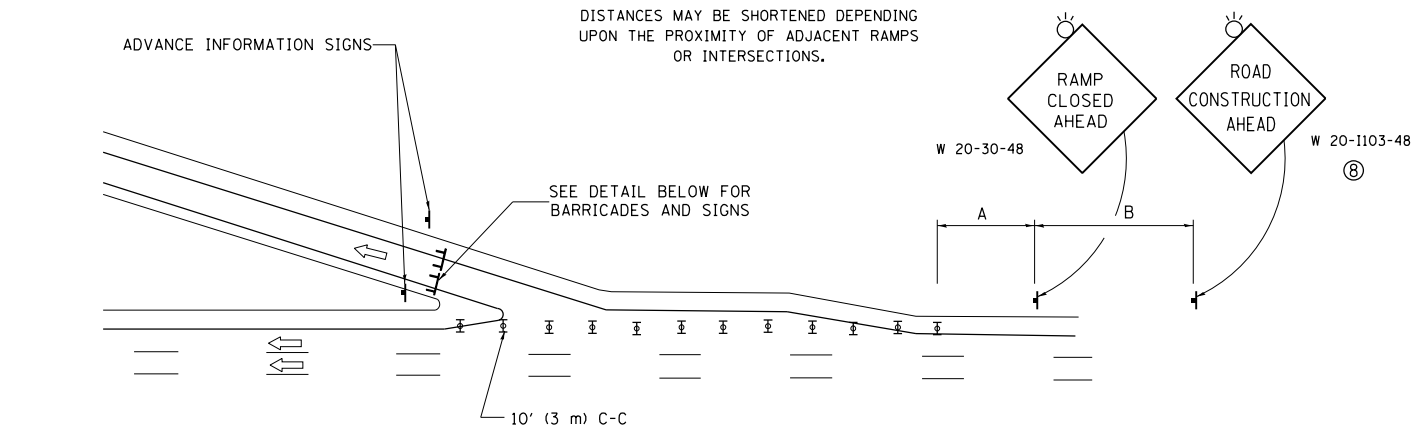


**ENTRANCE RAMP CLOSURE**

**SIGN SPACING TABLE**

FACILITY	DISTANCE BETWEEN SIGNS	
	A	B
EXPRESSWAY >24 HOURS	1000' (300 m)	1500' (450 m)
EXPRESSWAY <24 HOURS	500' (150 m)	500' (150 m)
ARTERIAL 55 MPH	500' (150 m)	500' (150 m)
ARTERIAL 50-45 MPH	350' (100 m)	350' (100 m)
ARTERIAL <45 MPH	200' (60 m)	200' (60 m)

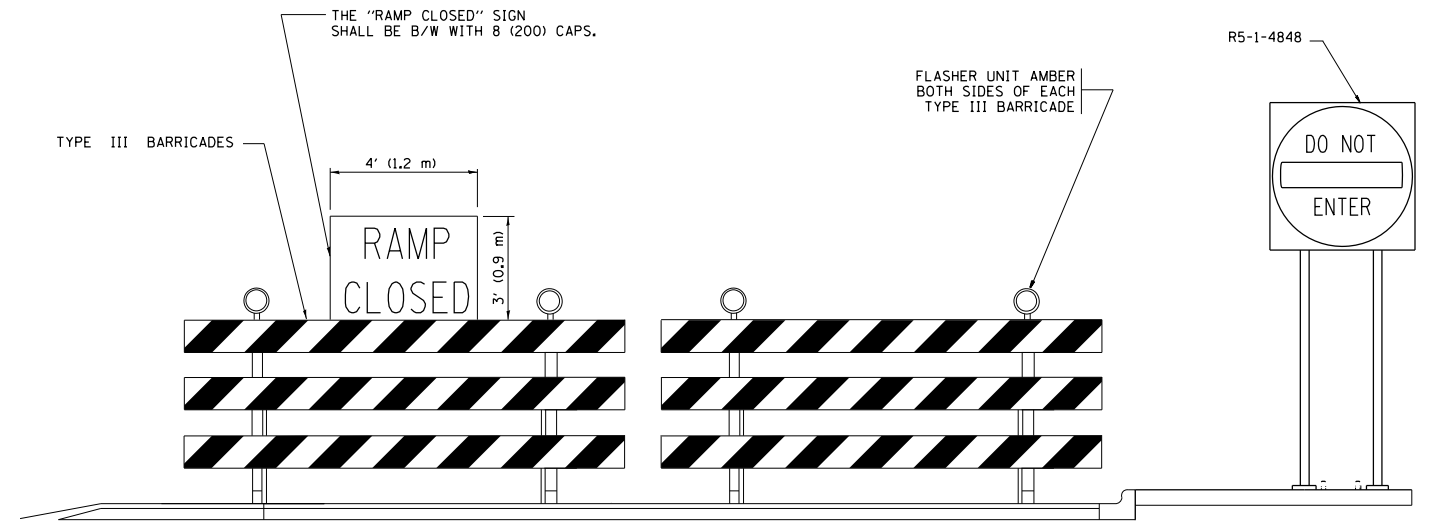
DISTANCES MAY BE SHORTENED DEPENDING UPON THE PROXIMITY OF ADJACENT RAMPS OR INTERSECTIONS.



**EXIT RAMP CLOSURE**

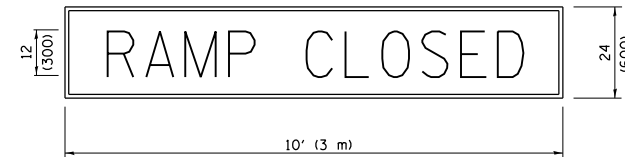
**SYMBOLS**

- ⊥ TYPE II BARRICADE OR DRUM
- ⊓ TYPE III BARRICADE WITH 2 FLASHING LIGHTS



**DETAIL FOR REQUIRED BARRICADES & SIGNS**

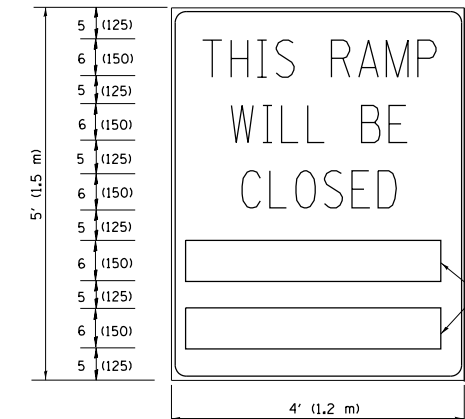
**RAMP CLOSURE ADVANCE WARNING SIGN**



BLACK LEGEND ON ORANGE BACKGROUND MOUNTED DIAGONALLY  
E MOD FONT  
1 (25) BORDER

THESE SIGNS ARE REQUIRED ON ALL THE EXIT GUIDE SIGNS FOR EXIT RAMPS THAT WILL BE CLOSED FOR MORE THAN FOUR (4) CONSECUTIVE DAYS.

**RAMP CLOSURE ADVANCE INFORMATION SIGN**



BLACK LEGEND ON WHITE BACKGROUND

1/2 (12) BORDER

E MOD FONT

THESE BLANK AREAS SHALL BE FILLED WITH THE DATES AND THE TIME THAT THE RAMP WILL BE CLOSED.

THESE SIGNS ARE REQUIRED ON BOTH SIDES OF THE RAMP, MINIMUM OF 1 WEEK IN ADVANCE OF THE CLOSURE.

THESE SIGNS SHALL BE FABRICATED AND PAID FOR ACCORDING TO THE TEMPORARY INFORMATION SIGNING SPECIAL PROVISION

**GENERAL NOTES:**

- ① CONES MAY BE SUBSTITUTED FOR DRUMS OR TYPE II BARRICADES DURING DAY OPERATIONS. CONES SHALL BE A MINIMUM OF 28 (700) HIGH.
- ② VERTICAL BARRICADES SHALL NOT BE USED FOR RAMP CLOSURES.
- ③ A FLAGGER SHALL BE POSITIONED AT EACH CLOSED RAMP THAT IS OPEN TO CONSTRUCTION VEHICLES, PRECEDED BY A W20-7 FLAGGER WARNING SIGN.
- ④ ALL ROUTE MARKERS AND TRAILBLAZER ASSEMBLIES WHICH DIRECT MOTORISTS TO A CLOSED ENTRANCE RAMP SHALL BE COVERED WHEN THE RAMP IS CLOSED FOR MORE THAN FOUR (4) DAYS.
- ⑤ THE SIGNING AND BARRICADING WHICH IS REQUIRED BY THIS DETAIL SHALL BE INCLUDED IN THE COST OF TRAFFIC CONTROL AND PROTECTION (EXPRESSWAYS).
- ⑥ AUTHORIZATION FROM THE DISTRICT'S BUREAU OF TRAFFIC IS REQUIRED FOR ALL RAMP CLOSURES.
- ⑦ THE RAMP CLOSURE ADVANCE INFORMATION SIGNS SHALL BE ERECTED IF THE CLOSURE TIME EXCEEDS TWENTY-FOUR (24) HOURS. ADDITIONAL ADVANCE WARNING SIGNS ON EXIT GUIDE SIGNING WILL BE REQUIRED FOR EXIT RAMP CLOSURES THAT EXCEED FOUR (4) DAYS IN LENGTH
- ⑧ ROAD CONSTRUCTION AHEAD SIGNS MAY BE OMITTED WHEN THIS DETAIL IS USED IN CONJUNCTION WITH OTHER TRAFFIC CONTROL THAT ALREADY INCLUDES A ROAD CONSTRUCTION AHEAD SIGN.
- ⑨ ARTERIAL ROAD CONSTRUCTION AHEAD SIGNS SHALL BE INSTALLED ON THE LEFT SIDE OF TRAFFIC IF THE MEDIAN IS MORE THAN 10 FT WIDE.

ALL DIMENSIONS ARE IN INCHES (MILLIMETERS) UNLESS OTHERWISE SHOWN.

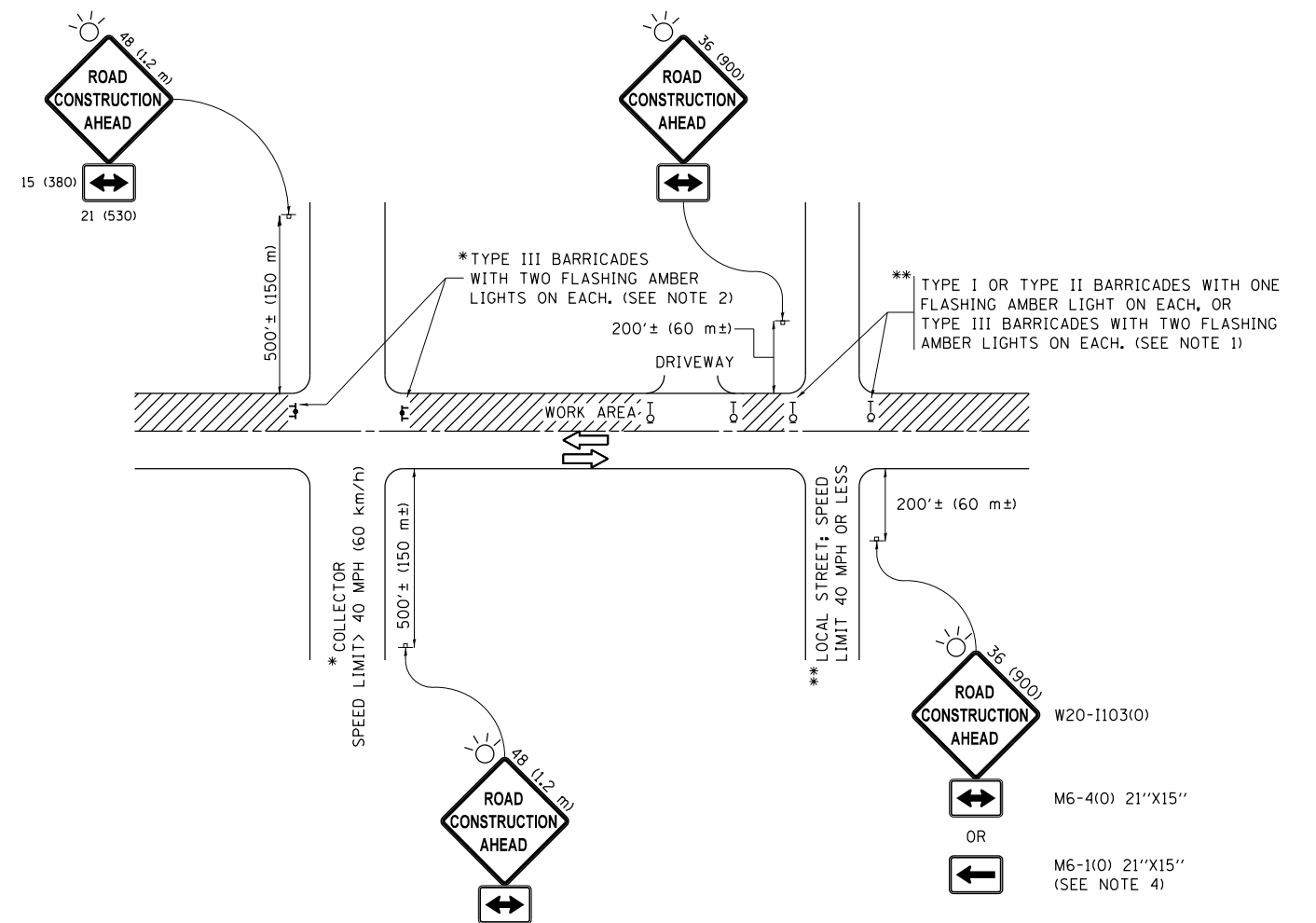
FILE NAME =	USER NAME = miduja	DESIGNED - D.W.S.	REVISED - S.P.B. 01-07
pw:\planroom.dot.illinois.gov\PIDOT\Documents\IDOT Offices\District 1\Projects\0144816\Drawings\Design\0144816-sht-plan.dgn		CHECKED -	REVISED - S.P.B. 12-09
Default	PLOT SCALE = 100.0000' / 1in.	DATE - 02-83	REVISED - M.D. 06-13
	PLOT DATE = 12/7/2019		REVISED - M.D. 01-18

**STATE OF ILLINOIS  
DEPARTMENT OF TRANSPORTATION**

**ENTRANCE AND EXIT RAMP  
CLOSURE DETAILS**

SCALE: NONE SHEET 1 OF 1 SHEETS STA. TO STA.

F.A. RTÉ.	SECTION	COUNTY	TOTAL SHEETS	SHEET NO.
VAR.	2019-138-1	VARIOUS	21	18
<b>TC-08</b>		<b>CONTRACT NO. 62K12</b>		
ILLINOIS FED. AID PROJECT				



**NOTES:**

1. SIDE ROAD WITH A SPEED LIMIT OF 40 MPH (60 km/h) OR LESS AS SHOWN ON THE DRAWING AND AS DIRECTED BY THE ENGINEER:
  - a) ONE "ROAD CONSTRUCTION AHEAD" SIGN 36 x 36 (900x900) WITH A FLASHER MOUNTED ON IT APPROXIMATELY 200' (60 m) IN ADVANCE OF THE MAIN ROUTE.
  - b) THE CLOSED PORTION OF THE MAIN ROUTE SHALL BE PROTECTED BY BLOCKING WITH TYPE I, TYPE II OR TYPE III BARRICADES, 1/3 OF THE CROSS SECTION OF THE CLOSED PORTION.
2. SIDE ROAD WITH A SPEED LIMIT GREATER THAN 40 MPH (60 km/h) AS SHOWN ON THE DRAWING AND AS DIRECTED BY THE ENGINEER:
  - a) ONE "ROAD CONSTRUCTION AHEAD" SIGN 48 x 48 (1.2 m x 1.2 m) WITH A FLASHER MOUNTED ON IT APPROXIMATELY 500' (150 m) IN ADVANCE OF THE MAIN ROUTE.
  - b) THE CLOSED PORTION OF THE MAIN ROUTE SHALL BE PROTECTED BY BLOCKING WITH TYPE III BARRICADES, 1/2 OF THE CROSS SECTION OF THE CLOSED PORTION.
3. CONES MAY BE SUBSTITUTED FOR BARRICADES OR DRUMS AT HALF THE SPACING DURING DAY OPERATIONS. CONES SHALL BE A MINIMUM OF 28 (710) IN HEIGHT.
4. WHEN THE SIDE ROAD LIES BETWEEN THE BEGINNING OF THE MAINLINE SIGNING AND THE WORK ZONE, A SINGLE HEADED ARROW (M6-1) SHALL BE USED IN LIEU OF THE DOUBLE HEADED ARROW (M6-4).
5. WHEN WORK IS BEING PERFORMED ON A SIDE ROAD OR DRIVEWAY, FOLLOW THE APPLICABLE STANDARD(S). THE DIRECTIONAL ARROW (M6-1 OR M6-4) SHALL BE COVERED OR REMOVED WHEN NO LONGER CONSISTENT WITH THE TRAFFIC CONTROL SET-UP.
6. ADVANCE WARNING SIGNS ARE TO BE OMITTED ON DRIVEWAYS UNLESS OTHERWISE SPECIFIED IN THE PLANS OR BY THE ENGINEER.
7. THE TRAFFIC CONTROL AND PROTECTION FOR SIDE ROADS, INTERSECTIONS, AND DRIVEWAYS SHALL BE INCLUDED IN THE COST OF SPECIFIED TRAFFIC CONTROL STANDARDS OR ITEMS.

All dimensions are in inches (millimeters) unless otherwise shown.

FILE NAME =	USER NAME = midyja	DESIGNED - L.H.A.	REVISED - A. HOUSEH 10-15-96
pw:\planroom.dot.illinois.gov\PIDOT\Documents\IDOT Offices\District 1\Projects\0144815\DRAWING\Design\0144816-sht-plan.dgn			REVISED - T. RAMMACHER 01-06-00
Default	PLOT SCALE = 100.0000' / in.	CHECKED -	REVISED - A. SCHUETZE 07-01-13
	PLOT DATE = 12/7/2019	DATE - 06-89	REVISED - A. SCHUETZE 09-15-16

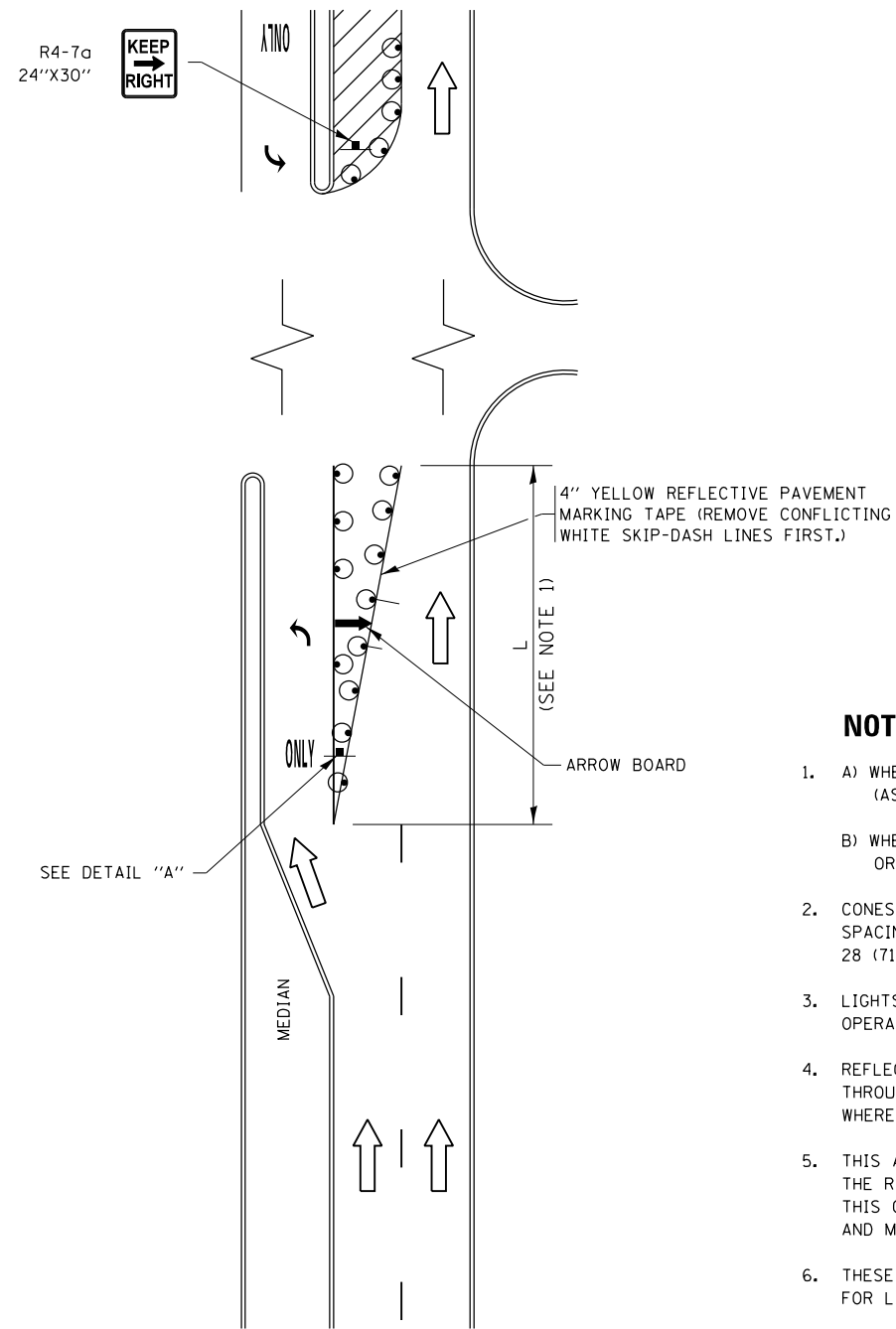
**STATE OF ILLINOIS  
DEPARTMENT OF TRANSPORTATION**

**TRAFFIC CONTROL AND PROTECTION FOR  
SIDE ROADS, INTERSECTIONS, AND DRIVEWAYS**

SCALE: NONE SHEET 1 OF 1 SHEETS STA. TO STA.

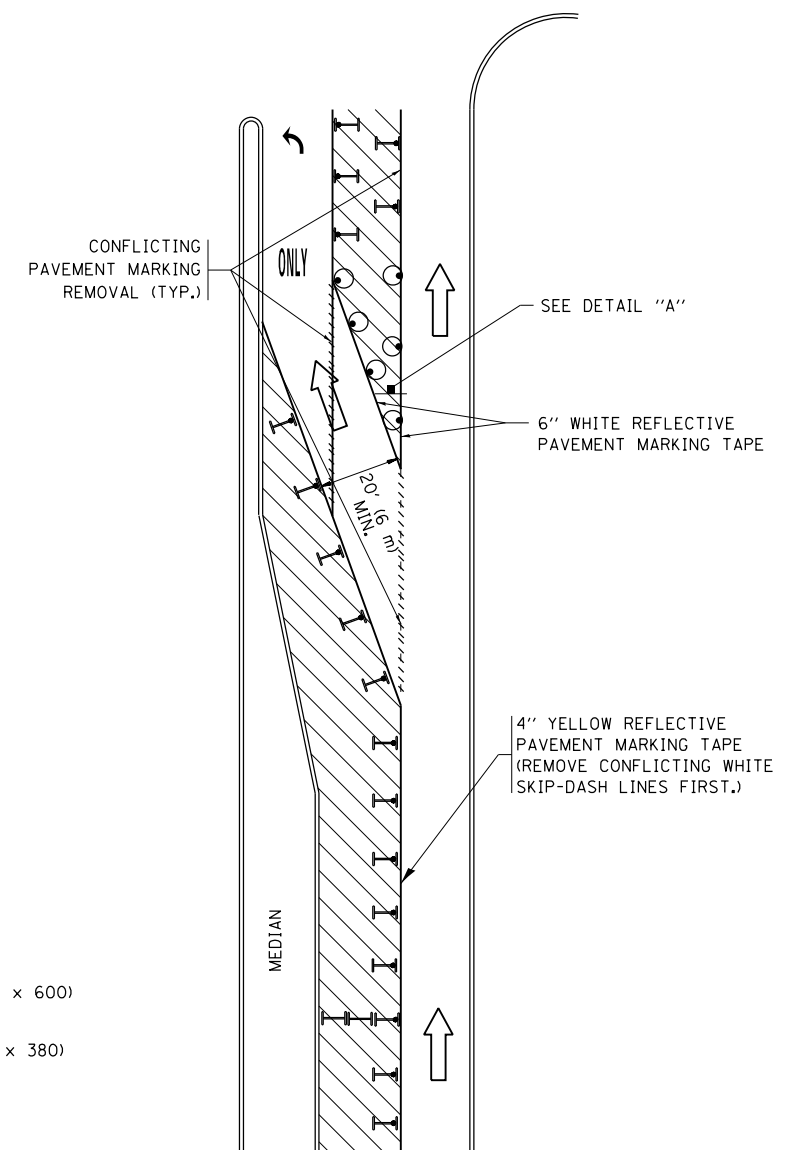
F.A. RTE.	SECTION	COUNTY	TOTAL SHEETS	SHEET NO.
VAR.	2019-138-1	VARIOUS	21	19
<b>TC-10</b>			<b>CONTRACT NO. 62K12</b>	
ILLINOIS FED. AID PROJECT				

# TURN BAY ENTRANCE AT START OF LANE CLOSURE TAPER

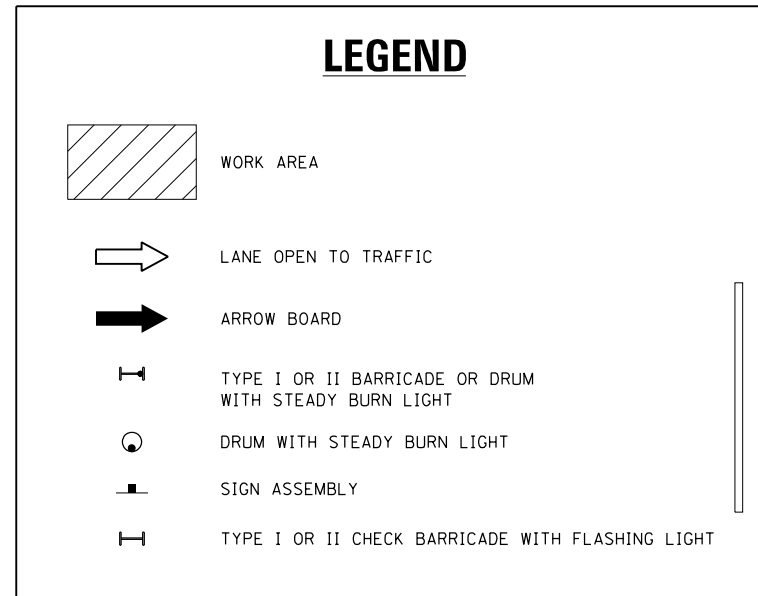


**FIGURE 1**

# TURN BAY ENTRANCE WITHIN A LANE CLOSURE

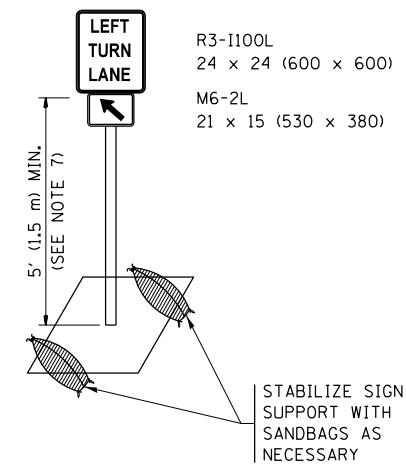


**FIGURE 2**



### NOTES:

1. A) WHEN "L" IS  $\leq$  THE STORAGE LENGTH OF THE TURN LANE (AS SHOWN IN FIG. 1), USE FIGURE 1.  
B) WHEN "L" IS  $>$  THE STORAGE LENGTH OF THE TURN LANE OR THE TURN LANE IS WITHIN THE LANE CLOSURE, USE FIGURE 2.
2. CONES MAY BE SUBSTITUTED FOR BARRICADES OR DRUMS AT HALF THE SPACING DURING DAY OPERATIONS. CONES SHALL BE A MINIMUM OF 28 (710) IN HEIGHT.
3. LIGHTS WILL NOT BE REQUIRED ON BARRICADES OR DRUMS FOR DAY OPERATIONS. ALL LIGHTS SHALL BE MONODIRECTIONAL.
4. REFLECTIVE TEMPORARY PAVEMENT MARKINGS SHALL BE PLACED THROUGHOUT THE BARRICADED AREAS OF EACH TURN BAY AS SHOWN WHERE THE CLOSURE TIME IS GREATER THAN FOURTEEN (14) DAYS.
5. THIS APPLICATION ALSO APPLIES WHEN WORK IS BEING PERFORMED IN THE RIGHT LANE(S) AND THE RIGHT TURN BAY IS TO REMAIN OPEN. UNDER THIS CONDITION, "RIGHT TURN LANE" R3-I100R 24 x 24 (600 x 600) AND M6-2R 21 x 15 (530 x 380) SHALL BE USED.
6. THESE CONTROLS SHALL SUPPLEMENT MAINLINE TRAFFIC CONTROL FOR LANE CLOSURES.
7. THE SIGNS SHALL BE MOUNTED ABOVE THE BARRICADES/DRUMS ON SEPARATE SIGN SUPPORTS THAT MEET NCHRP 350 OR MASH PREQUIREMENTS.
8. TRAFFIC CONTROL AND PROTECTION AT TURN BAYS (TO REMAIN OPEN TO TRAFFIC) SHALL BE INCLUDED IN THE COST OF SPECIFIED TRAFFIC CONTROL STANDARDS OR ITEMS.

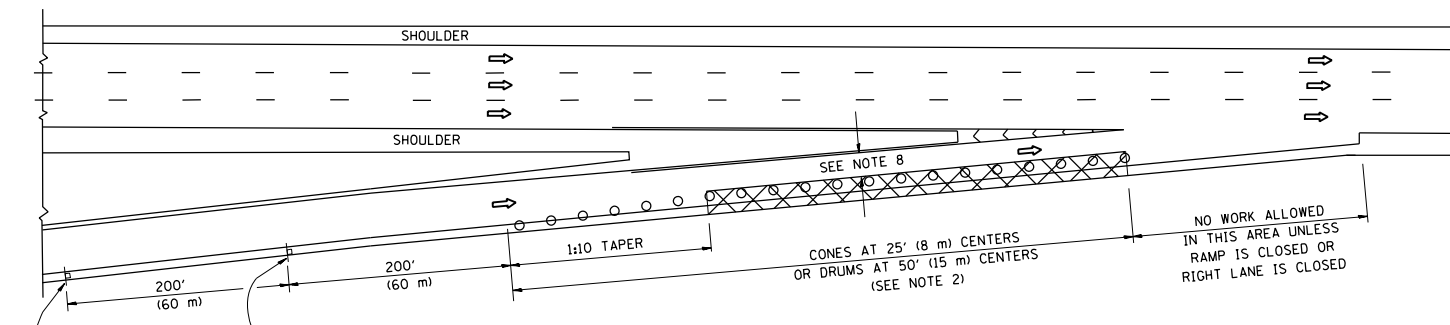


**DETAIL A**

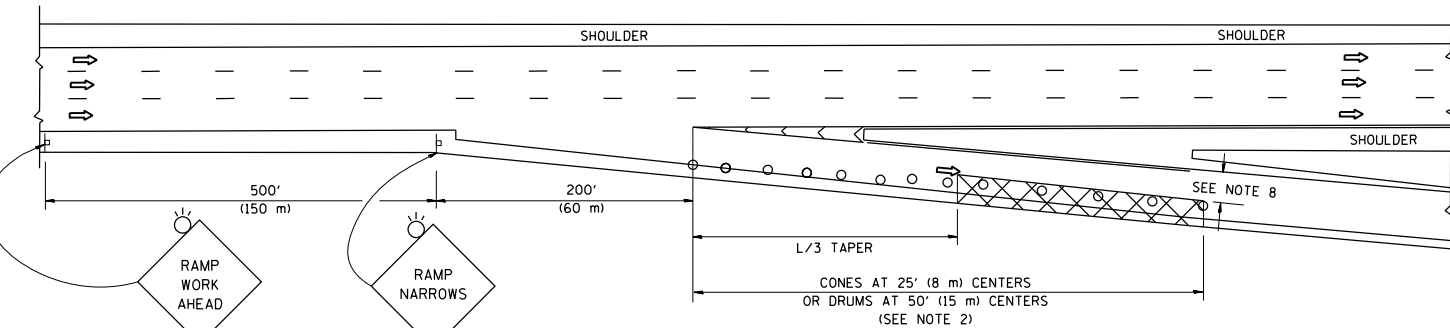
All dimensions are in inches (millimeters) unless otherwise shown.

FILE NAME =	USER NAME = miduja	REVISED - T. RAMMACHER 09-08-94	REVISED - R. BORO 09-14-09	<b>STATE OF ILLINOIS DEPARTMENT OF TRANSPORTATION</b>	<b>TRAFFIC CONTROL AND PROTECTION AT TURN BAYS (TO REMAIN OPEN TO TRAFFIC)</b>	F.A. RTÉ.	SECTION	COUNTY	TOTAL SHEETS	SHEET NO.
pw:\planroom.dot.illinois.gov\PIDOT\Documents\IDOT Offices\District 1\Projects\0144815\REVISED Design\DI\HOUSEH\11-07-95	REVISED - A. HOUSEH 11-07-95	REVISED - A. SCHUETZE 07-01-13	REVISED - A. SCHUETZE 07-01-13			VAR.	2019-138-1	VARIOUS	21	20
Default	PLOT SCALE = 100.0000' / in.	REVISED - A. HOUSEH 10-12-96	REVISED - A. SCHUETZE 09-15-16			<b>TC-14</b>		<b>CONTRACT NO. 62K12</b>		
	PLOT DATE = 12/7/2019	REVISED - T. RAMMACHER 01-06-00	REVISED -			SCALE: NONE		SHEET 1 OF 1 SHEETS		STA. TO STA.

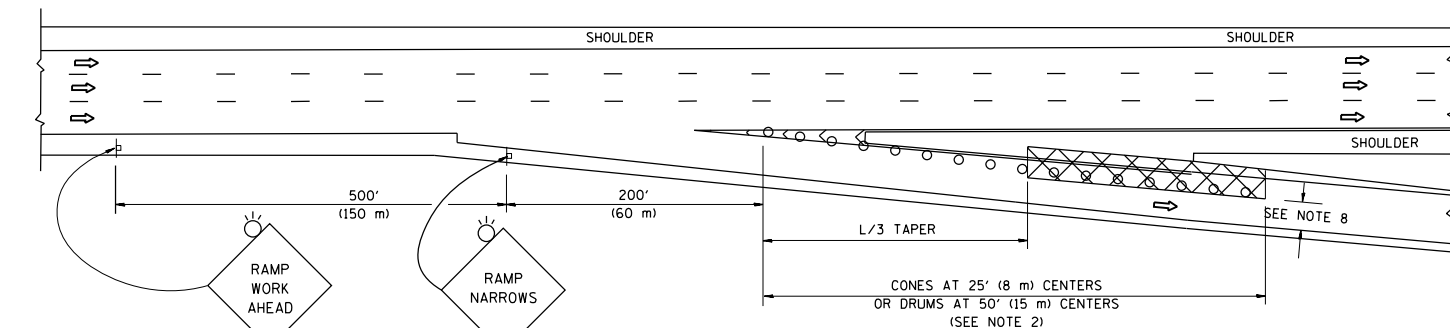
PARTIAL RAMP CLOSURE DETAILS



TYPICAL ENTRANCE RAMP



TYPICAL EXIT RAMP



TYPICAL EXIT RAMP

SYMBOLS

- ACTIVE WORK AREA
- SIGN ON PORTABLE OR PERMANENT SUPPORT
- FLAGGER WITH CONTROL SIGN
- TYPE II BARRICADE OR DRUM
- CONE, DRUM OR BARRICADE
- IMPACT ATTENUATOR OF TYPE AND TEST LEVEL SPECIFIED

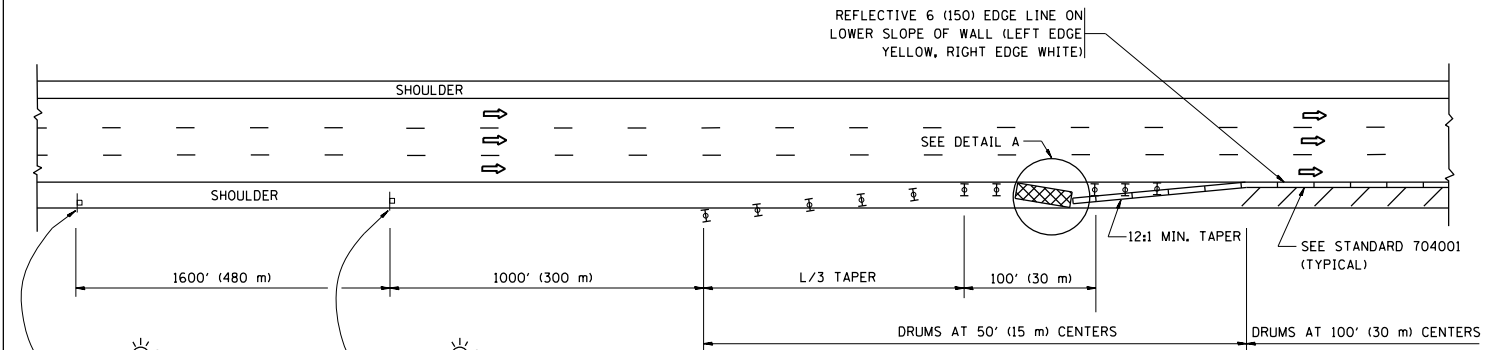
GENERAL NOTES

1. THE "L" DISTANCE EQUALS:  

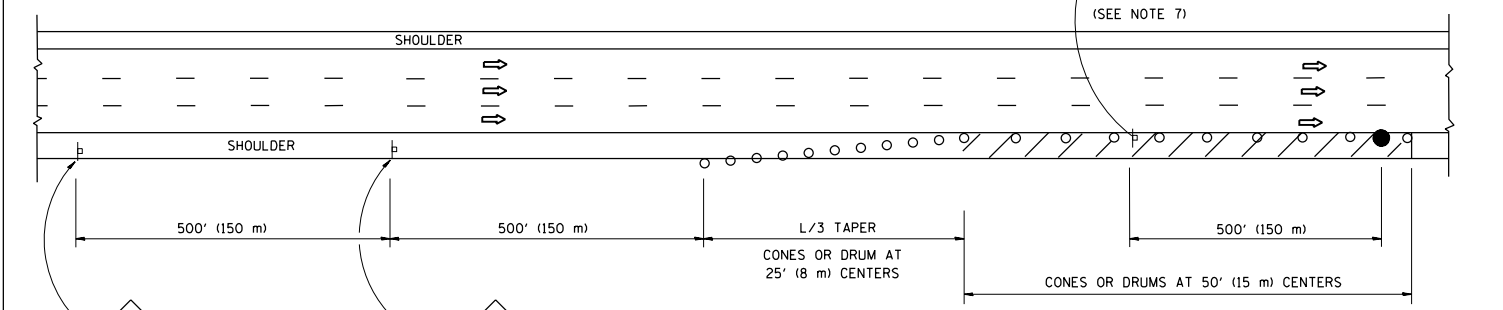
SPEED LIMIT	FORMULAS
45 mph (80 km/h)	METRIC ENGLISH
OR GREATER:	$L=0.65(W)(S)$ $L=(W)(S)$

W = WIDTH OF OFFSET IN FEET (METERS)  
 S = NORMAL POSTED SPEED MPH (KM/H)
2. TYPE II BARRICADES OR DRUMS ARE REQUIRED FOR ALL NIGHTTIME CLOSURES. TYPE II BARRICADES OR DRUMS WITH MONODIRECTIONAL STEADY BURN LIGHTS ARE REQUIRED FOR DELINEATING OBSTACLES, EXCAVATIONS, OR HAZARDS EXCEEDING 100 FT (30m) IN LENGTH AT NIGHT.
3. ALL SIGNS SHALL BE POST MOUNTED IF THE CLOSURE TIME EXCEEDS FOUR DAYS.
4. FLASHING LIGHTS SHALL BE USED DURING THE HOURS OF DARKNESS AND SHALL BE INSTALLED ABOVE THE FIRST TWO SETS OF SIGNS.

SHOULDER CLOSURE DETAILS

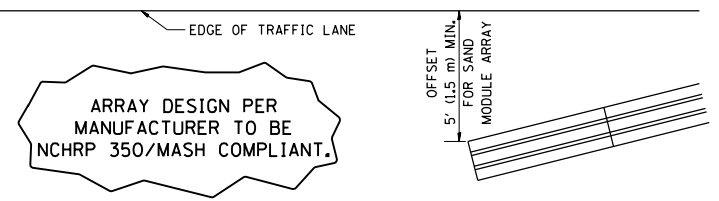


PERMANENT SHOULDER CLOSURE



DAYTIME SHOULDER CLOSURE

THIS DETAIL IS USED WHERE:  
 1. VEHICLES, EQUIPMENT, WORKERS OR THEIR ACTIVITIES ENCRANCH IN AN AREA CLOSER THAN 15' (4.5 m) TO THE EDGE OF PAVEMENT FOR A PERIOD IN EXCESS OF 15 MINUTES.



DETAIL "A"  
 IMPACT ATTENUATOR, TEMPORARY  
 (SEE NOTE 5)

5. THE IMPACT ATTENUATOR, TEMPORARY IS NOT REQUIRED WHEN THE TEMPORARY CONCRETE BARRIER WALL IS PROTECTED BY OR IS TIED INTO THE EXISTING GUARDRAIL. IF OFFSET IS LESS THAN 5 FEET USE NARROW USE TYPE DEVICE TO MEET NCHRP350/MASH.
6. AUTHORIZATION FROM THE DISTRICT'S BUREAU OF TRAFFIC IS REQUIRED FOR ALL FREEWAY CLOSURES.
7. THE FLAGGER AND FLAGGER SIGN ARE REQUIRED AT THE ABOVE WORK SITES WHEN:
  - a. FOUR OR MORE WORK VEHICLES ENTER THE TRAFFIC LANES IN A ONE HOUR PERIOD.
  - b. THE WORK AVTIVITY REQUIRES FREQUENT ENCRACHMENT INTO THE LANE OPEN TO TRAFFIC.
 THE FLAGGER SHALL BE STATIONED APPROXIMATELY 100' (30 m) TO 200' (60 m) IN ADVANCE OF THE WORKERS.
8. 12' MIN. WIDTH TANGENT SECTION  
 16' MIN. WIDTH CURVE SECTION.

ALL DIMENSIONS ARE IN INCHES (MILLIMETERS) UNLESS OTHERWISE SHOWN.

FILE NAME =	USER NAME = midyja	DESIGNED -	REVISED - S.P.B. 01-07	<b>STATE OF ILLINOIS DEPARTMENT OF TRANSPORTATION</b>	<b>TRAFFIC CONTROL DETAILS FOR FREEWAY SHOULDER CLOSURES AND PARTIAL RAMP CLOSURES</b>	F.A. RTE.	SECTION	COUNTY	TOTAL SHEETS	SHEET NO.
pw:\planroom.dot.illinois.gov\PIWIDOT\Documents\IDOT Offices\District 1\Projects\0144815\Drawings\Design\0144815\15sht-plan.dgn	PLLOT SCALE = 100.0000' / 1in.	CHECKED -	REVISED - S.P.B. 12-09			VAR.	2019-138-1	VARIOUS	21	21
Default	PLLOT DATE = 12/7/2019	DATE - 11-96	REVISED - M.D. 06-13			<b>TC-17</b>		<b>CONTRACT NO. 62K12</b>		
			REVISED - M.D. 01-18			SCALE: NONE	SHEET 1 OF 1 SHEETS	STA. TO STA.	ILLINOIS FED. AID PROJECT	