

SIDE VIEW (TRUSS ARM)
N.T.S.

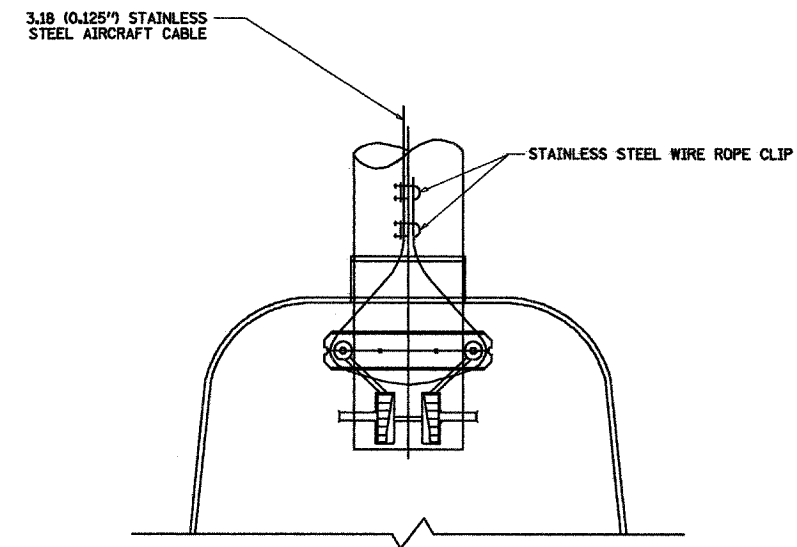

BOTTOM VIEW
N.T.S.

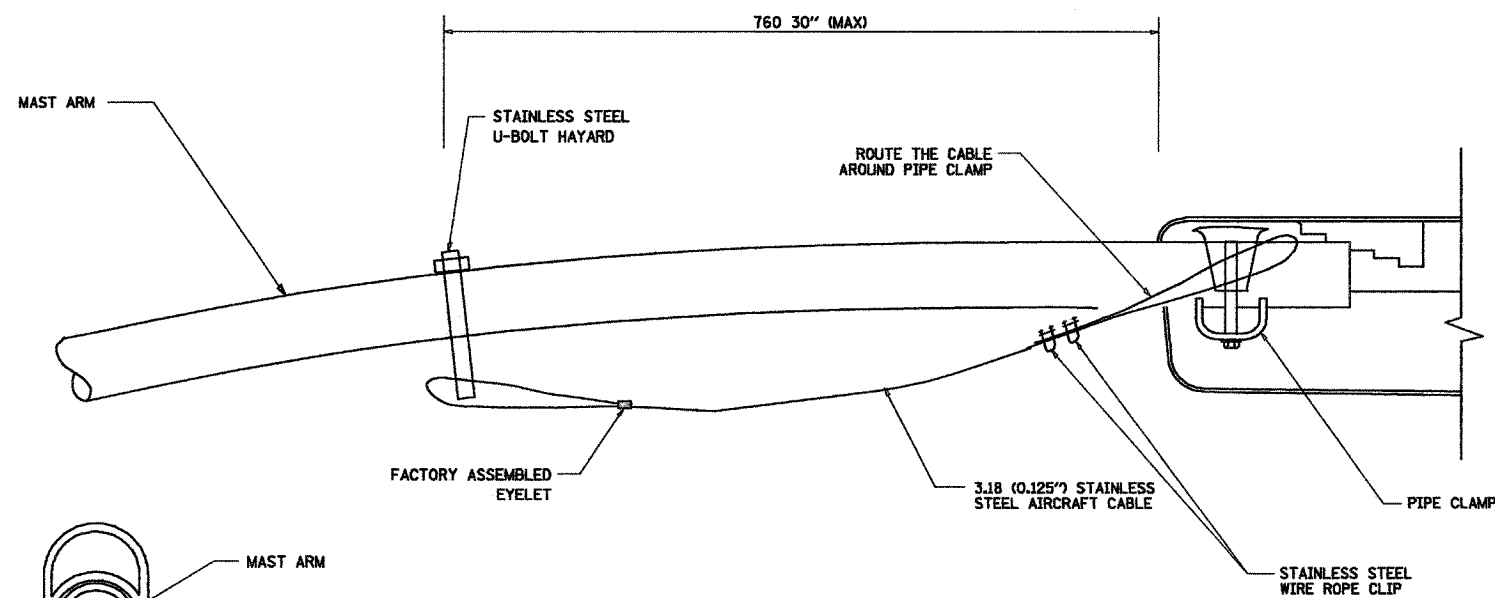

SIDE VIEW (SINGLE MEMBER OR DAVIT ARM)
N.T.S.

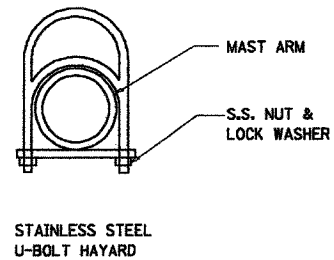

NOTES:

1. ALL DIMENSIONS ARE IN MILLIMETERS (INCHES) UNLESS OTHERWISE SHOWN
2. CONTRACTOR SHALL ADJUST THE WIRE CLIP TO ELIMINATE ANY SLACK FROM THE WIRE ROPE.
3. THE 3.18 (0.125") STAINLESS STEEL AIRCRAFT CABLE SHALL REMAIN VISIBLE FROM THE GROUND LEVEL.
4. THE BREAKING STRENGTH OF THE CABLE SHALL BE 1700 LBS. MIN

REVISIONS	
NAME	DATE

ILLINOIS DEPARTMENT OF TRANSPORTATION

LUMINAIRE SAFETY
CABLE ASSEMBLY

SCALE: VERT.
HORIZ.
DATE: 2/15/2006

DRAWN BY
CHECKED BY
BE-701

REVISION DATE: