

CONTRACT NO. 72943

F.A.U. RTE.	SECTION	COUNTY	TOTAL SHEETS	SHEET NO.
*	11RS-8	ADAMS	64	53
STA.		TO STA.		
FED. ROAD DIST. NO.	ILLINOIS	FED. AID PROJECT		
* 7810 & 7825 (IL 96)				

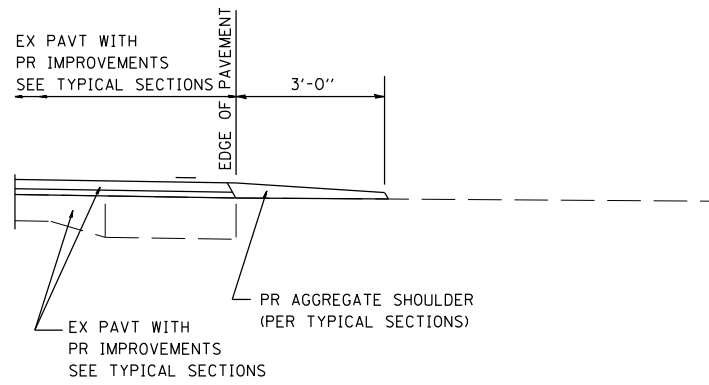

SECTION A-A FOR EX EARTH/ AGGREGATE FE

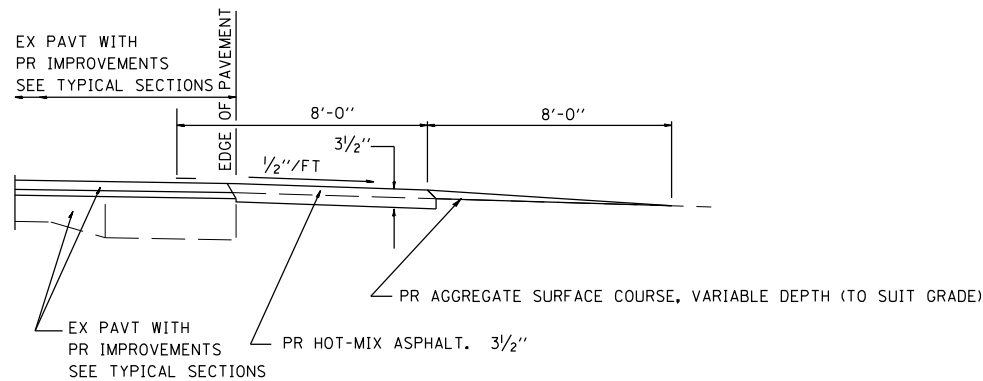

SECTION A-A FOR EX EARTH/AGGREGATE PE

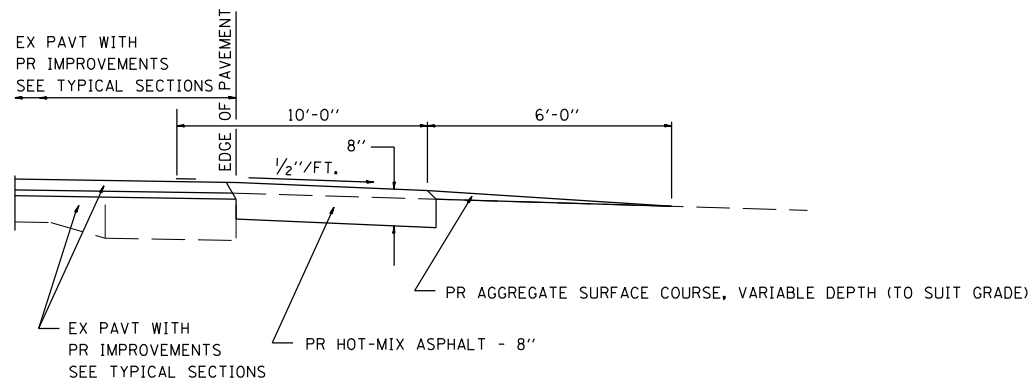

SECTION A-A FOR EX EARTH/AGGREGATE CE & SIDE ROAD

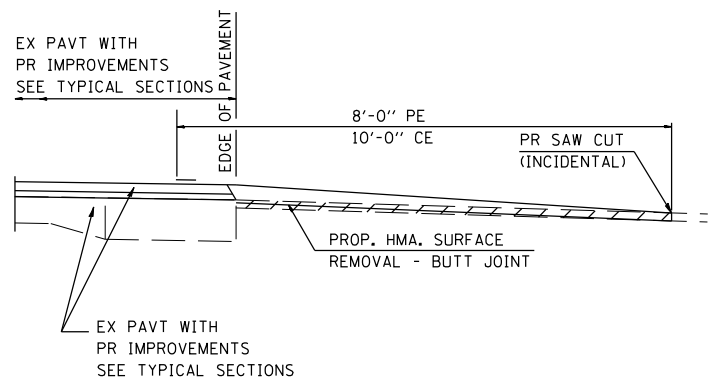

SECTION A-A FOR EX BITUMINOUS/ PC CONCRETE PE, CE & SIDE ROAD

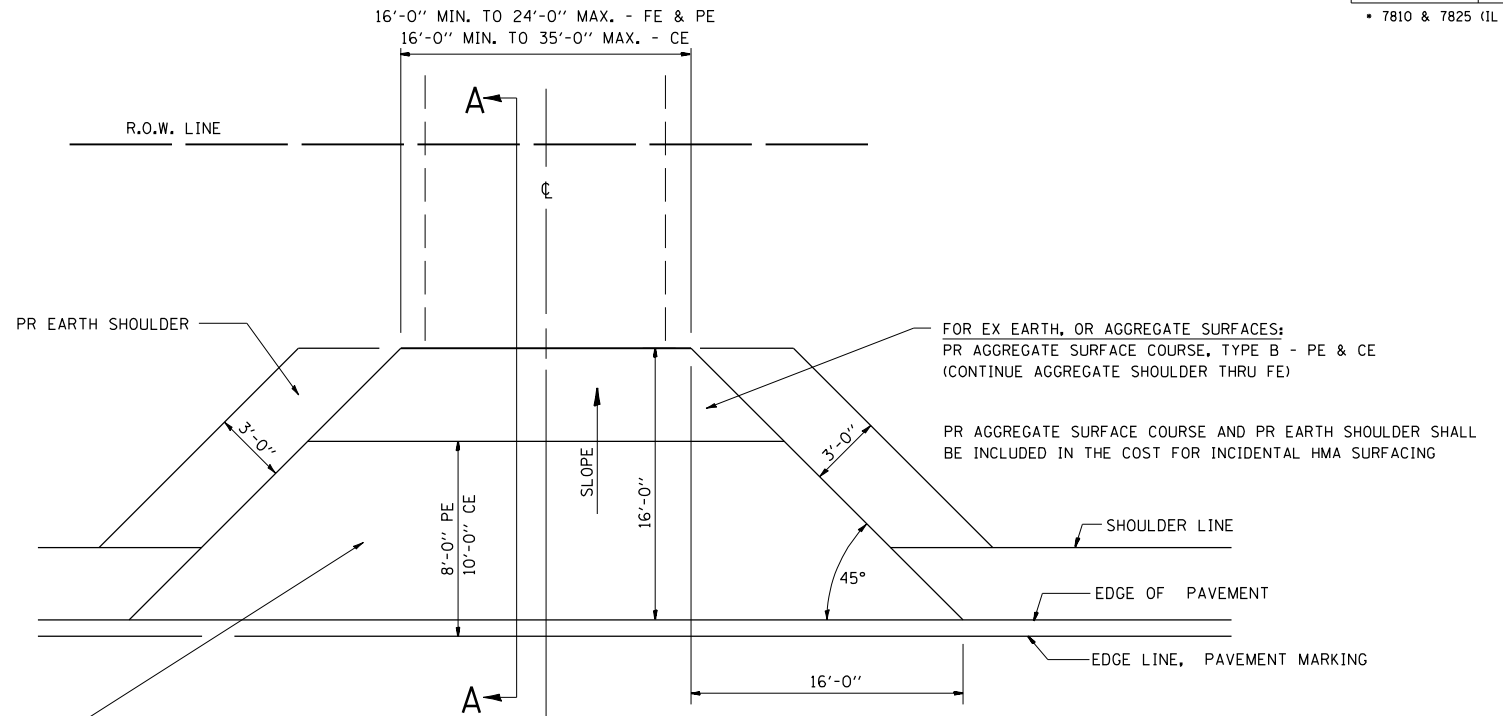

FOR EX EARTH OR AGGREGATE SURFACES:  
 PR HMA SURFACE REMOVAL (IF APPLICABLE)  
 PR AGGREGATE SHOULDER THRU - FE  
 PR HOT-MIX ASPHALT 3 1/2" - PE  
 PR HOT-MIX ASPHALT 8" - CE

FOR HOT-MIX ASPHALT OR P.C. CONCRETE SURFACES:  
 PR HOT-MIX ASPHALT SURFACE REMOVAL, VARIABLE DEPTH

GENERAL NOTES:

THE RESIDENT ENGINEER WILL DETERMINE THE EXACT TYPE OF IMPROVEMENT TO BE COMPLETED FOR ALL ENTRANCES, SIDEROADS AND MAILBOX TURNOUTS ON THIS PROJECT.

THE PLAN DETAILS AND SCHEDULES SHOULD BE USED AS A GUIDE FOR THE ENGINEER TO IMPLEMENT THE FINAL DESIGN. THE ENGINEER MAY DECIDE TO SALVAGE PORTIONS OF THE EXISTING ENTRANCE PAVEMENT STRUCTURE; THEREFORE, REDUCING PAYITEM QUANTITIES. NO ADDITIONAL PAYMENT WILL BE ALLOWED FOR THIS REDUCTION IN QUANTITIES.

ANY WORK THE ENGINEER REQUIRES WHICH IS NOT COVERED BY A PAY ITEM CONTAINED IN THE PLANS WILL BE PAID FOR IN ACCORDANCE WITH ARTICLE 109.04 OF THE STANDARD SPECIFICATIONS.

HOT-MIX ASPHALT CONCRETE REQUIRED TO CONSTRUCT THE ENTRANCES SHALL BE IN ACCORDANCE WITH THE APPLICABLE PORTIONS OF SECTION 406 AND 408 OF THE STANDARD SPECIFICATIONS AND AS DIRECTED BY THE ENGINEER.

PR. AGGREGATE SURFACE COURSE, VARIABLE DEPTH (TO SUIT GRADE) FOR EX EARTH/AGGR PE, CE, & SIDE RD SHALL BE INCLUDED IN THE COST FOR INCIDENTAL HMA SURFACING.

WHEN THE HOT-MIX ASPHALT PROPOSED FOR THE IMPROVEMENT IS THICKER THAN 3 INCHES AND REQUIRE PLACEMENT IN MORE THAN ONE LIFT. THE BOTTOM LIFT(S) SHALL MEET THE REQUIREMENTS OF HOT-MIX ASPHALT BASE COURSE IN SECTION 406 OF THE STANDARD SPECIFICATIONS AND THE TOP LIFT OF 2 INCHES SHALL MEET THE REQUIREMENTS OF HOT-MIX ASPHALT SURFACE COURSE, MIXTURE C, CLASS I, TYPE 2 OF SECTION 406 OF THE STANDARD SPECIFICATIONS.

THIS WORK WILL BE PAID FOR AT THE CONTRACT UNIT PRICE PER TON FOR "INCIDENTAL HOT-MIX ASPHALT SURFACING" WHICH SHALL INCLUDE ALL MATERIALS, EQUIPMENT, AND LABOR INVOLVED.

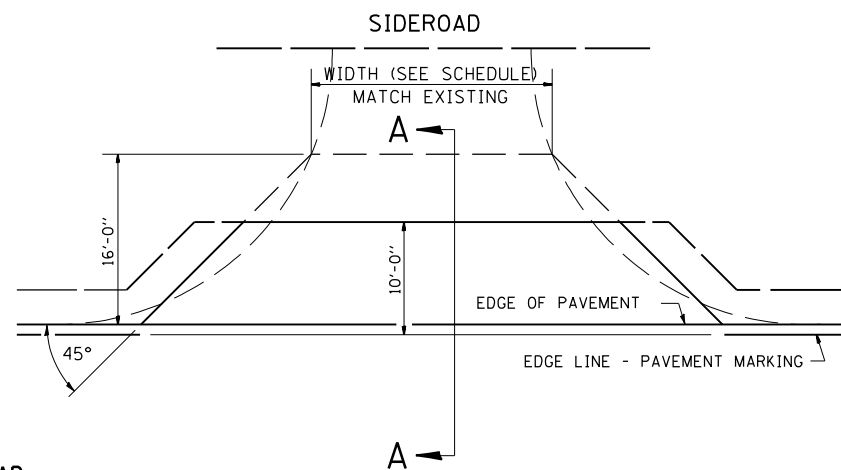

ALL DIMENSIONS ARE IN INCHES UNLESS OTHERWISE SHOWN.

REVISIONS	
NAME	DATE

ILLINOIS DEPARTMENT OF TRANSPORTATION  
**DETAILS FOR RURAL  
 ENTRANCE, MAILBOX TURNOUT  
 & SIDE ROAD**

(SHEET 1 OF 3)

SCALE: VERT.  
 HORIZ.  
 DATE: MAY 21, 2004

DRAWN BY: CAD  
 CHECKED BY: RSC

PLOT DATE = No-02-2007 01:15:08PM  
 FILE NAME = c:\projects\6550605\shdetails.dgn  
 PLOT SCALE = 1/8"=1'-0" / IN.  
 USER NAME = laughlin-1