

Operator: dhaberling

Date: 11/26/2007

Filename: L:\Jobs\IDOT BBS\6727 BBS Various Various\6727.09\CADD\_S\N. 039-0009\rev 1.dgn

STATE OF ILLINOIS  
DEPARTMENT OF TRANSPORTATION

ROUTE NO.	SECTION	COUNTY	NO. SHEETS	SHEET NO.
FAP 42		Jackson	10 10	2
FED. ROAD DIST. NO.		ILLINOIS	REPAIR PROJECT	

Contract # 78036

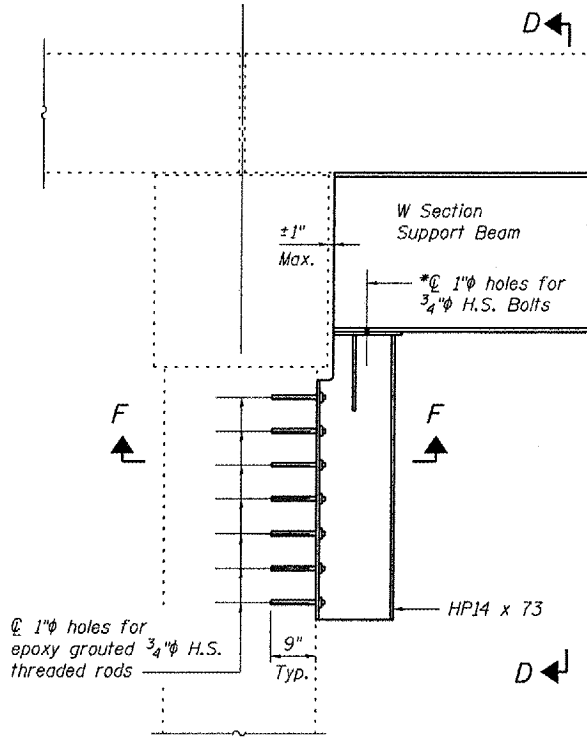

SECTION A-A  
(At Pier 3 & Pier 4)

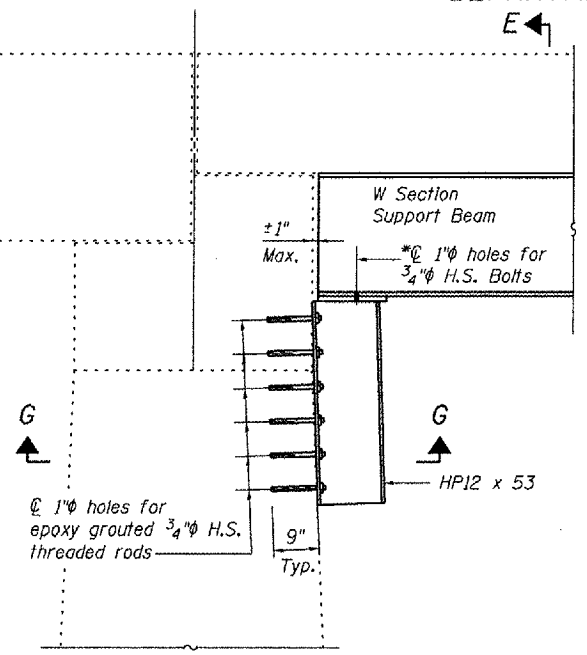

SECTION B-B  
(At Pier 7)

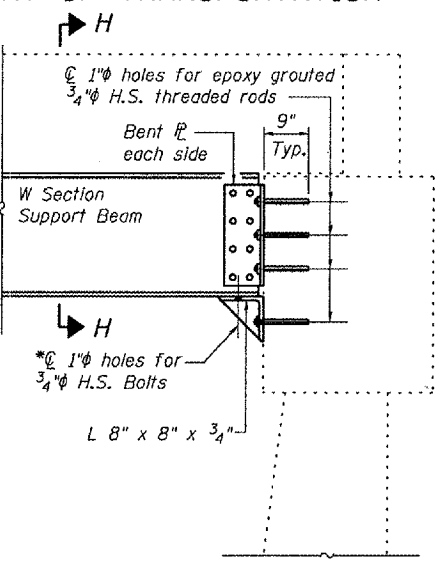

SECTION C-C  
(At N. Abut.)

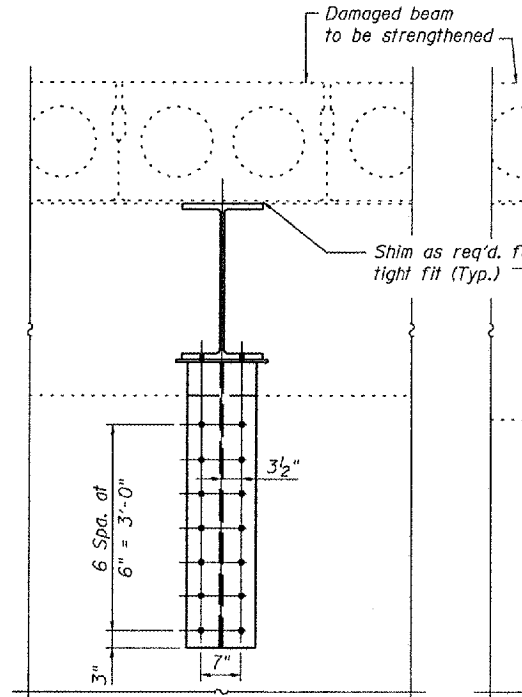

SECTION D-D

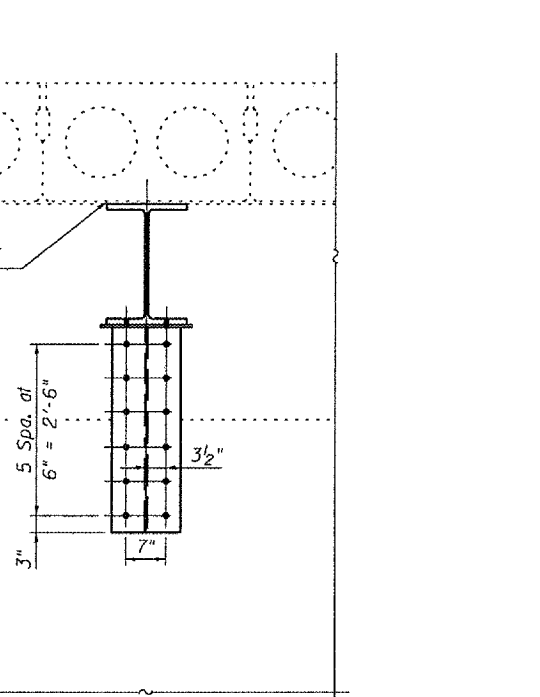

SECTION E-E

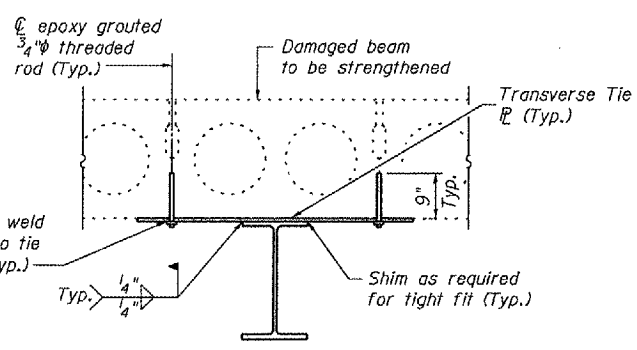

SECTION I-I

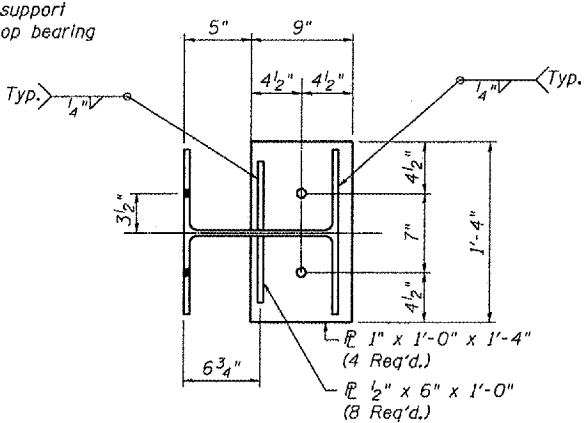

SECTION F-F

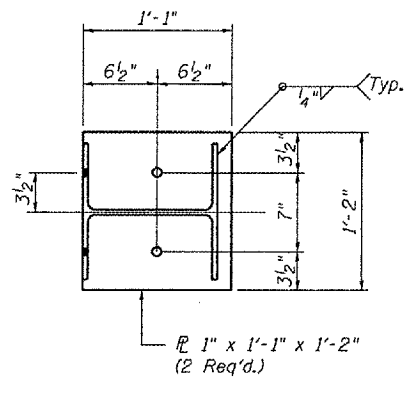

SECTION G-G

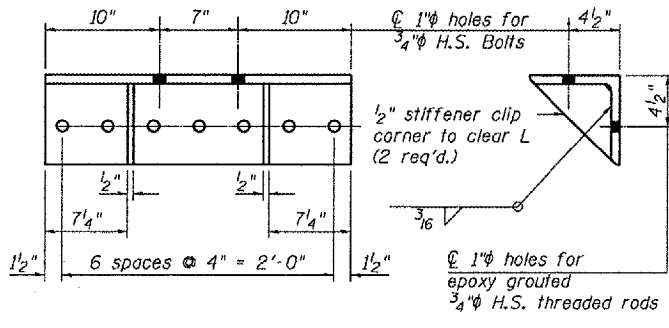

SECTION H-H  
(At N. Abut.)

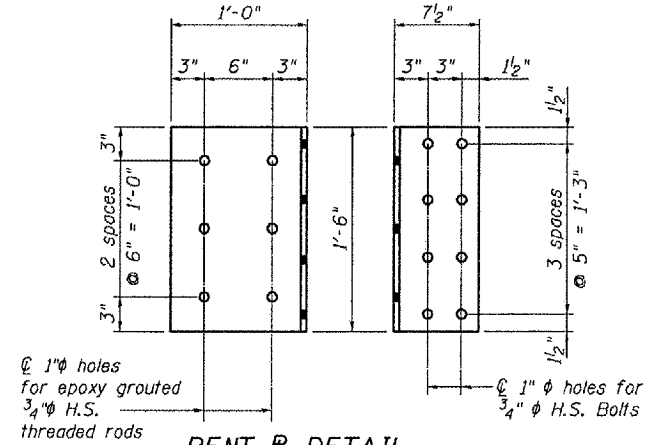

BENT PLATE DETAIL

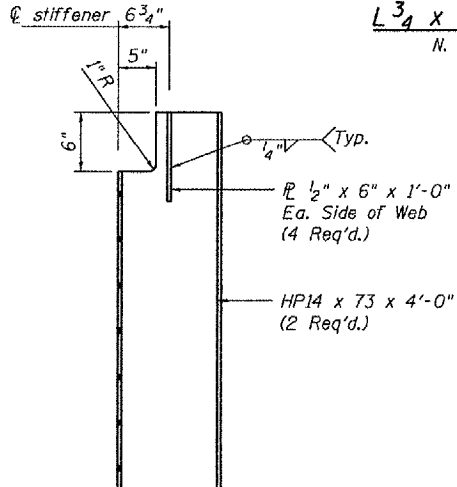

TYPICAL HP SECTION  
(Pier 3 & 4)

L 3/4 x 8 x 8 x 2'-3"  
N. Abut. (2 Req'd.)

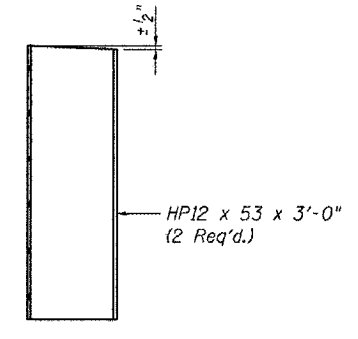

TYPICAL HP SECTION  
(Pier 7)

\*Field drill holes in support beam using hole in top bearing plate as a template.

DESIGNED	CMV
CHECKED	SDS
DRAWN	DLH
CHECKED	CMV

**WHKS & CO.**  
ENGINEERS PLANNERS LAND SURVEYORS  
MASON CITY, IOWA DUBUQUE, IOWA AMES, IOWA  
E. DUBUQUE, ILLINOIS SPRINGFIELD, ILLINOIS ROCHESTER, MINNESOTA

REPAIR DETAILS  
IL RTE 13 & IL RTE 127  
OVER BEAUCOUP CREEK  
JACKSON COUNTY  
S.N. 039-0009