

**GENERAL NOTES**

- Plan dimensions and details relative to existing plans are subject to nominal construction variations. The Contractor shall field verify existing dimensions and details affecting new construction and make necessary approved adjustments prior to construction or ordering of materials. Such variations shall not be cause for additional compensation for a change in scope of the work, however, the Contractor will be paid for the quantity actually furnished at the unit price bid for the work.
- All exposed concrete edges shall have a 3/4" x 45° chamfer, except where shown otherwise.
- Reinforcement bars designated (E) shall be epoxy coated.
- Bars noted thus, 3 x 2-#5 indicates 3 lines of bars with 2 lengths of bars per line.
- A distance of half the length of the wingwall, but not less than six feet of the barrel shall be poured monolithically with the wingwalls.
- For "Stone Riprap, Class A4" and "Filter Fabric for use with Riprap" Bill of Material, see Roadway plans.
- Layout of slope protection system may be varied in the field to suit ground conditions as directed by the Engineer.
- It shall be the responsibility of the contractor to divert the stream flow during construction in order to keep the construction area free of water. The method of the water diversion shall be subjected to the approval of the Engineer and the cost shall be included with the cost of concrete box culverts.
- The contractor shall salvage and re-erect the existing guardrail, and chain link fence.
- Precast culvert will not be allowed.

**INDEX OF SHEETS**

- S2-01 General Plan and Elevation
- S2-02 General Notes, Index of Sheets & Bill of Material
- S2-03 Stage Construction
- S2-04 Temporary Concrete Barrier
- S2-05 Plan & Elevation I
- S2-06 Plan & Elevation II
- S2-07 Sections and Details
- S2-08 Bar Splicer Assembly Details
- S2-09 Temporary Support System Plan, Sections and Details
- S2-10 Boring Logs

**TOTAL BILL OF MATERIAL**

ITEM	UNIT	TOTAL
Removal and Disposal of Unsuitable Material	Cu. Yd.	273
Porous Granular Embankment	Cu. Yd.	224
Removal of Existing Structures No. 2	Each	1
Reinforcement Bars, Epoxy Coated	Pound	9,810
Bar Splicers	Each	30
Concrete Box Culverts	Cu. Yd.	40.4
Temporary Sheet Piling	Sq. Ft.	280
Temporary Support System, Location 2	Each	1

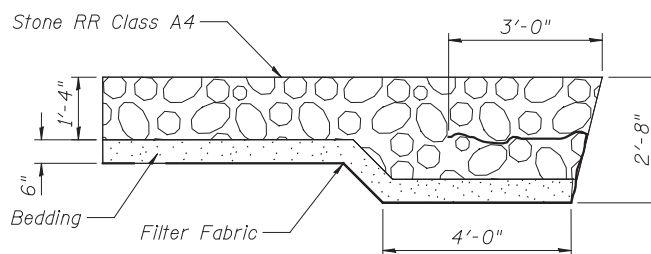

**SECTION A-A**

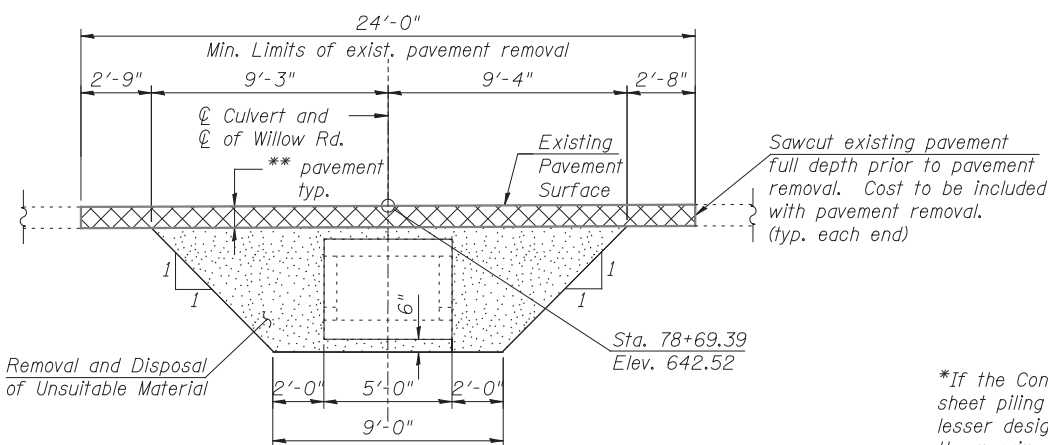

**STAGE I REMOVAL CROSS SECTION**

(All dimensions are perpendicular to C of culvert unless noted)

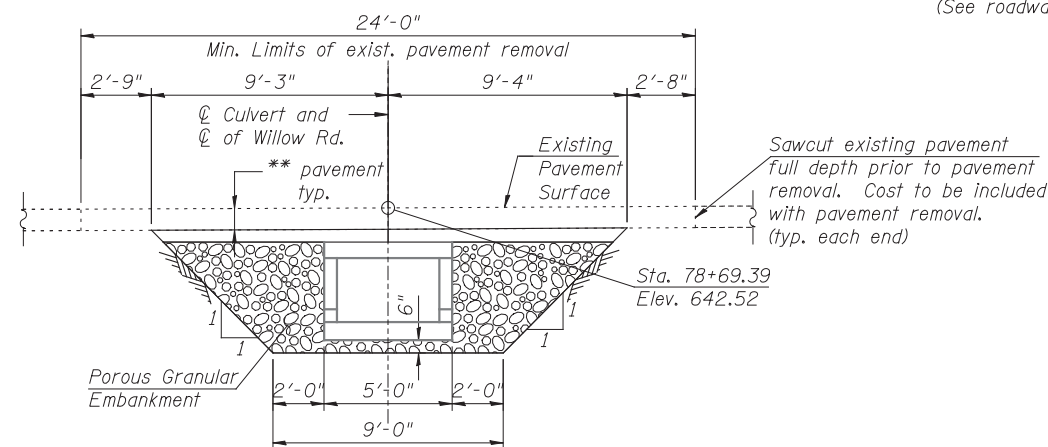

**STAGE I CONST. CROSS SECTION**

(All dimensions are perpendicular to C of culvert unless noted)

\*If the Contractor chooses to alter the temporary cantilevered sheet piling design requirements shown on the plans for lesser design requirements, then full design submittals with the required seals will be expected by the Department, for review and approval

\*\* Depth of pavement to match existing (See roadway plans for details)

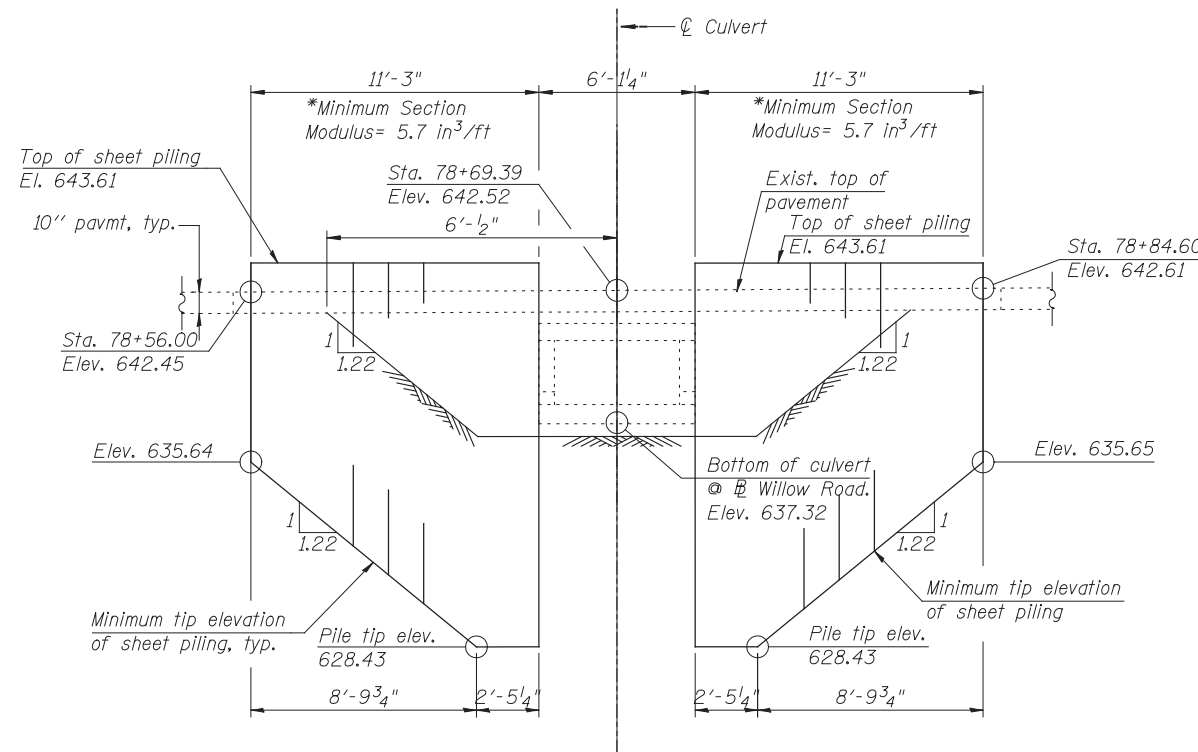

**TEMPORARY SHEET PILING DESIGN**

(All dimensions are along the front face of existing culvert)

**BILL OF MATERIAL**

ITEM	UNIT	TOTAL
Removal and Disposal of Unsuitable Material	Cu. Yd.	273
Porous Granular Embankment	Cu. Yd.	224
Removal of Existing Structures No. 2	Each	1
Temporary Sheet Piling	Sq. Ft.	280

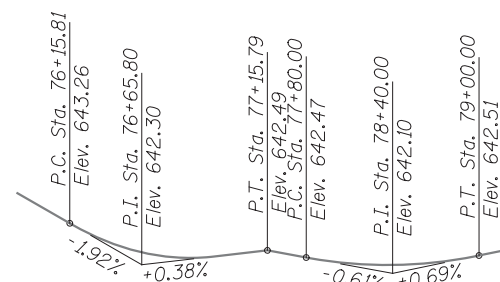

**WESTBOUND PROFILE GRADE**

(Willow Road)

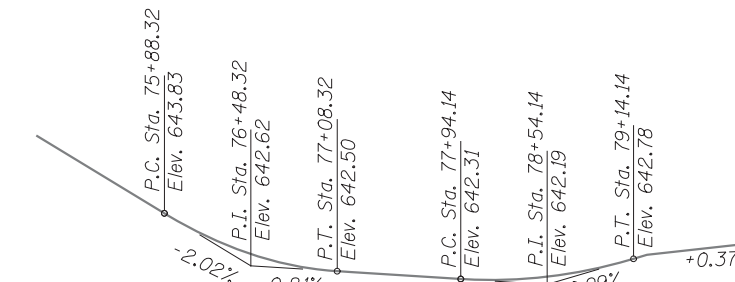

**EASTBOUND SOUTH PROFILE GRADE**

(Willow Road)