

- NOTES:**
1. ALL DIMENSIONS ARE IN MILLIMETERS (INCHES) UNLESS OTHERWISE SHOWN.
 2. MOUNTING HEIGHT IS DEFINED AS THE DISTANCE FROM THE CENTERLINE OF THE TENON TO THE BOTTOM OF THE ANCHOR BASE.
 3. THE LIGHT POLE WILL MEET AASHTO DESIGN CRITERIA AS SPECIFIED.
 4. THE INSTALLING CONTRACTOR WILL PROVIDE A UL LISTED GROUNDING CONNECTOR, BURNDY K2C23, T & B SP4DL OR APPROVED EQUAL.
 5. LIGHT POLES WILL NOT BE INSTALLED WITHOUT MAST ARMS AND LUMINAIRES.
 6. LIGHT POLES WILL BE SET PLUMB ON THE FOUNDATION WITHOUT THE USE OF LEVELING NUTS, WASHERS OR SHIMS.

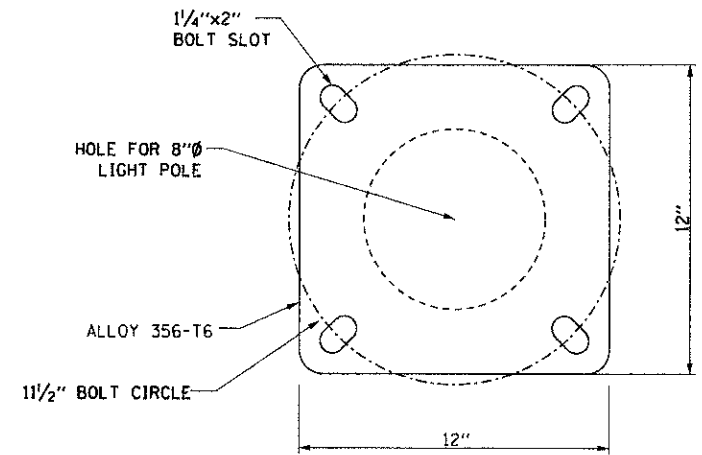

LIGHT POLE BASE PLATE DETAIL
11 1/2 INCH BOLT CIRCLE

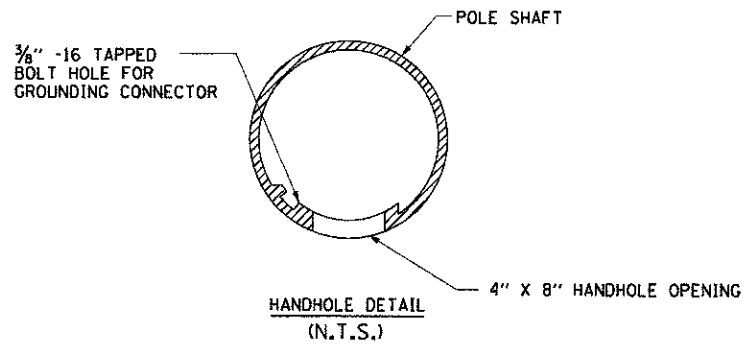

HANDHOLE DETAIL
(N.T.S.)

12/19/2012 3:46:29 PM
RPL-08.dgn
pdf, dwg, no, level, plot, q
standard-trans.tbl

HRGreen.com
11/12/12 Professional Design Firm
#194-001322

USER NAME = jettene	DESIGNED -	REVISED -
FILE NAME = RLP-08.dgn	DRAWN -	REVISED -
PLOT SCALE =	CHECKED -	REVISED -
PLOT DATE = 12/19/2012	DATE = 12/19/12	REVISED -

MCHENRY COUNTY
DIVISION OF TRANSPORTATION

LIGHTING PLAN
ALUMINUM LIGHT POLE 35'-0" MOUNTING HEIGHT

SCALE: SHEET NO. 7 OF 13 SHEETS STA. TO STA.

F.A.U. RTE.	SECTION	COUNTY	TOTAL SHEETS	SHEET NO.
168	05-00314-00-WR	MCHENRY	187	115
FED. ROAD DIST. NO.			ILLINOIS FED. AID PROJECT	

RPL-08

CONTRACT NO. 63515