

PROPOSED TYPICAL SECTION - PARKVIEW TERR.  
STA 10+00 TO STA 12+00

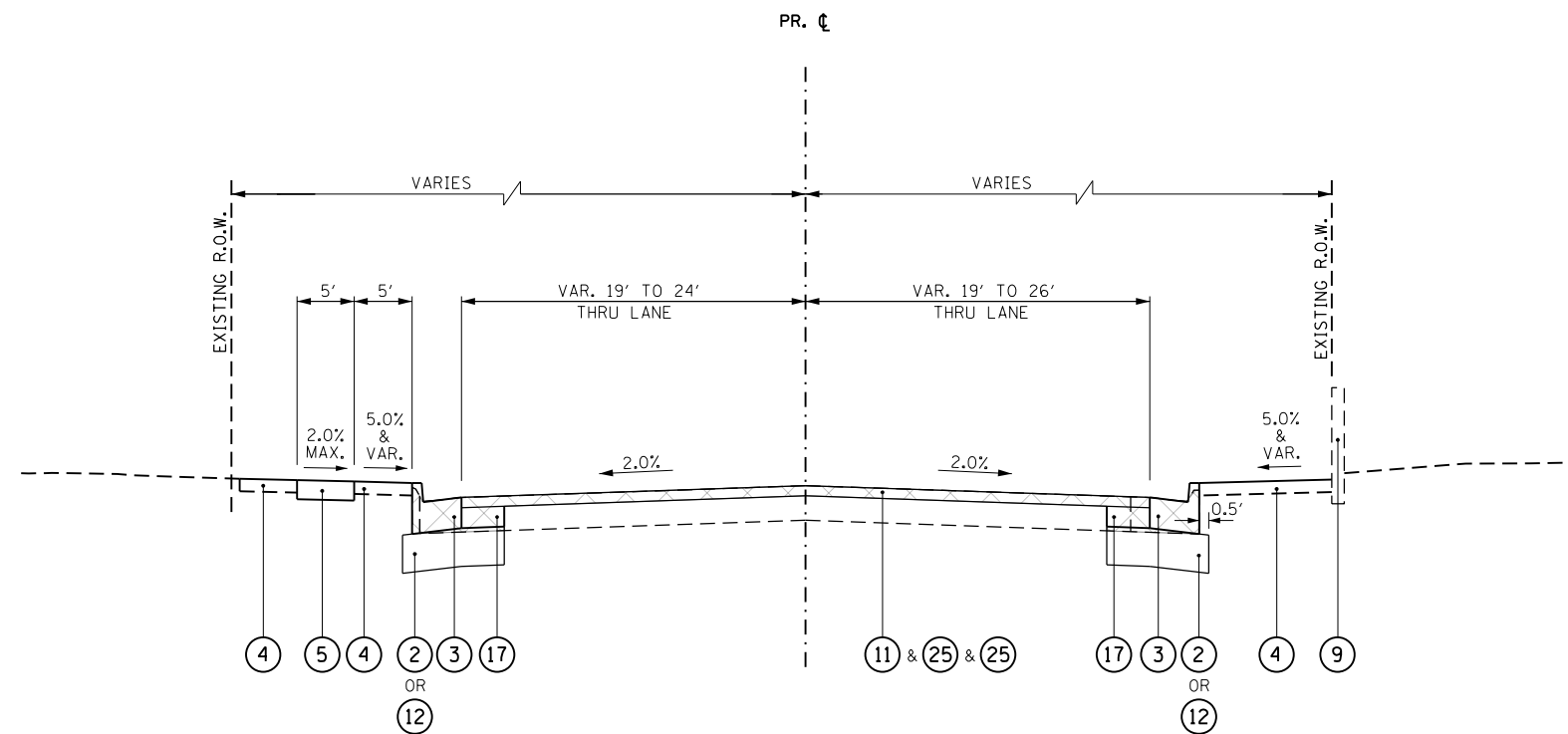

PROPOSED TYPICAL SECTION - MARCHESANO DR.  
STA 54+40 TO STA 57+20

GEOTECHNICAL REINFORCEMENT  
FROM STA 55+00 TO STA 57+20

AGGREGATE SUBGRADE IMPROVEMENT:  
12" FROM STA 54+40 TO STA 55+00  
15" FROM STA 55+00 TO STA 57+20

LEGEND

- ① PORTLAND CEMENT CONCRETE PAVEMENT, 9 1/2" (JOINTED)
- ② AGGREGATE SUBGRADE IMPROVEMENT 12"
- ③ COMBINATION CONCRETE CURB AND GUTTER, TYPE B-6.24
- ④ TOPSOIL FURNISH AND PLACE, 6"
- ⑤ PORTLAND CEMENT CONCRETE SIDEWALK, 5"
- ⑥ EXISTING BIKE PATH
- ⑦ COMBINATION CONCRETE CURB AND GUTTER, TYPE B-6.12
- ⑧ TOPSOIL FURNISH AND PLACE, SPECIAL
- ⑨ EXISTING BRICK WALL
- ⑩ EXISTING ORNAMENTAL FENCE
- ⑪ 1 1/2" HMA SURFACE COURSE MIX "C", N50
- ⑫ AGGREGATE SUBGRADE IMPROVEMENT
- ⑬ SEGMENTAL CONCRETE BLOCK WALL
- ⑭ CONCRETE MEDIAN SURFACE, 4 INCH
- ⑮ CORRUGATED MEDIAN
- ⑯ AGGREGATE SUBGRADE IMPROVEMENT 18"
- ⑰ PORTLAND CEMENT CONCRETE BASE COURSE WIDENING 10"
- ⑱ AGGREGATE SUBGRADE IMPROVEMENT 24"
- ⑲ AGGREGATE FILL
- ⑳ 2" HOT-MIX ASPHALT SURFACE COURSE IL-9.5FG N50
- ㉑ AGGREGATE BASE COURSE, TYPE B, 8"
- ㉒ COMBINATION CONCRETE CURB AND GUTTER, TYPE B-6.18
- ㉓ PIPE UNDERDRAINS 6"
- ㉔ 2" INCIDENTAL HOT-MIX ASPHALT SURFACING
- ㉕ HOT-MIX ASPHALT SURFACE REMOVAL, 2 1/2"
- ㉖ 1" LEVELING BINDER (MACHINE METHOD), N50

NOTE:  
HMA MIXTURE APPLICATION RATE = 112 LBS/SQ YD/IN

\* GUTTER FLAG REVERSE PITCHED TO 2% AWAY FROM MEDIAN

|             |                       |            |           |   |   |              |           |                    |         |        |              |           |
|-------------|-----------------------|------------|-----------|---|---|--------------|-----------|--------------------|---------|--------|--------------|-----------|
| FILE NAME = | USER NAME = \$USER*   | DESIGNED - | REVISED - | <b>STATE OF ILLINOIS<br/>DEPARTMENT OF TRANSPORTATION</b> | <b>PROPOSED TYPICAL SECTIONS</b>              |              |           | F.A.P. RTE.        | SECTION | COUNTY | TOTAL SHEETS | SHEET NO. |
| *FILEL\$    |                       | DRAWN -    | REVISED - |   | 742   | (32, 33) R-1 | WINNEBAGO | 705                | 33      |        |              |           |
|             | PLOT SCALE = \$SCALE* | CHECKED -  | REVISED - |   | SCALE: SHEET NO. 13 OF 20 SHEETS STA. TO STA. |              |           | CONTRACT NO. 64821 |         |        |              |           |
|             | PLOT DATE = \$DATE*   | DATE -     | REVISED - |   | ILLINOIS FED. AID PROJECT                     |              |           |                    |         |        |              |           |