

**SINGLE CONDUIT ASSEMBLY**

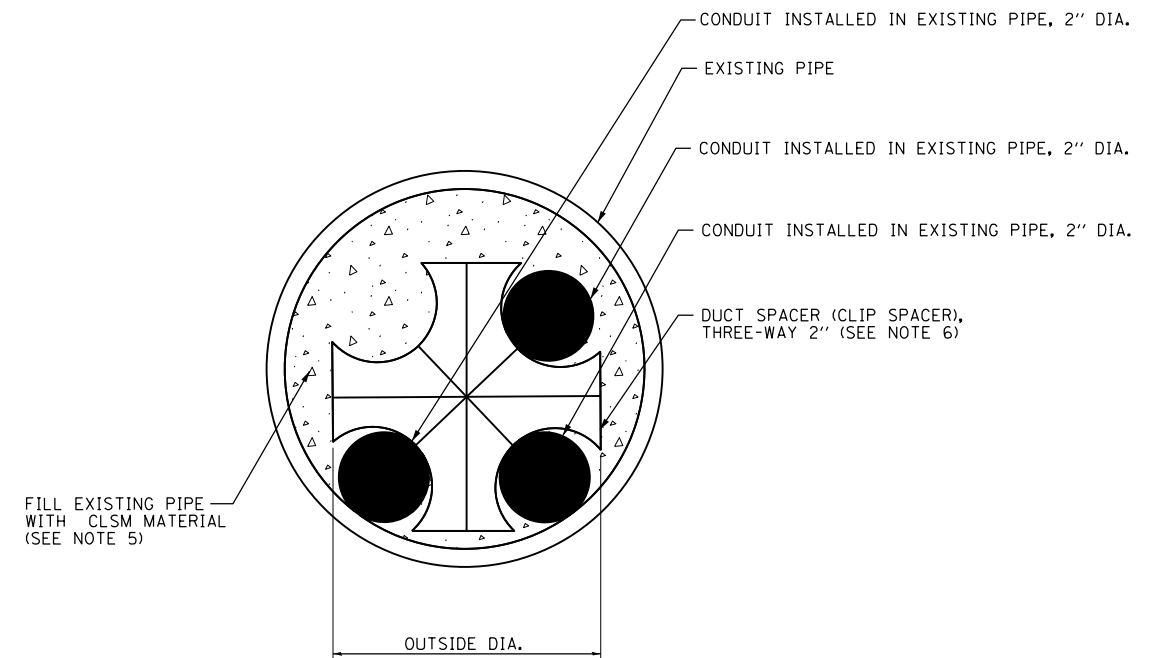

**TRIPLE CONDUIT ASSEMBLY**

**NOTES:**

1. USE ONE DUCT SPACER (CLIP SPACER) FOR EVERY 5 FEET OF EXISTING PIPE CASING.
2. INSTALL DUCT SPACERS PERPENDICULAR TO CONDUITS TO REDUCE THE TENDENCY OF CONDUITS TO CORKSCREW.
3. CONTRACTOR MUST COORDINATE WITH DUCT SPACER MANUFACTURER ON INSTALLATION MEANS TO PREVENT THE DUCTBANK FROM ROTATING DURING INSTALLATION. DUCT SPACERS MUST BE HELD IN PLACE WITH NON-METALLIC STRAPS AND HOLD DOWN BARS.
4. THE DUCTBANK MUST BE HELD IN POSITION AT BOTH ENDS TO ACCOMMODATE POSSIBLE UNEVEN THRUST LOADS THAT MAY BE GENERATED DURING THE GROUTING OPERATION.
5. THE COST FOR FILLING THE EXISTING PIPE WITH CLSM SHALL BE INCLUDED IN THE CONTRACT UNIT COST FOR CONDUIT INSTALLED IN EXISTING PIPE.
6. THE COST FOR DUCT SPACERS AND ANY ASSOCIATED STRAPS USED TO HOLD THE CONDUIT IN PLACE SHALL BE INCLUDED IN THE CONTRACT UNIT COST FOR CONDUIT INSTALLED IN EXISTING PIPE.

DIRECTORY = I:\ROCKFORD\118004\Draw\CAD\Sheet\26\4821\_DIA.dwg  
 USER NAME = Jensen Dove



MODEL NAME = Default	DESIGNED - JWD	REVISED -
FILE NAME = D:\264821\eh\Light\26.dgn	DRAWN - JWD	REVISED -
PLOT SCALE = 40.0000' / in.	CHECKED - AB	REVISED -
PLOT DATE = 11/20/2012 - 11:29:33 AM	DATE - 11/02/2012	REVISED -

**STATE OF ILLINOIS  
DEPARTMENT OF TRANSPORTATION**

ROADWAY LIGHTING DETAIL	
CONDUIT INSTALLED IN EXISTING PIPE WITH DUCT SPACERS	
SCALE: N/A	SHEET 26 OF 32 SHEETS STA. TO STA.

F.A.P. RTE.	SECTION	COUNTY	TOTAL SHEETS	SHEET NO.
742	(32, 33) R-1	WINNEBAGO	705	512
CONTRACT NO. 64821			ILLINOIS FED. AID PROJECT	