

**DETAIL 1A**

Approach slab reinforcement not shown for clarity.

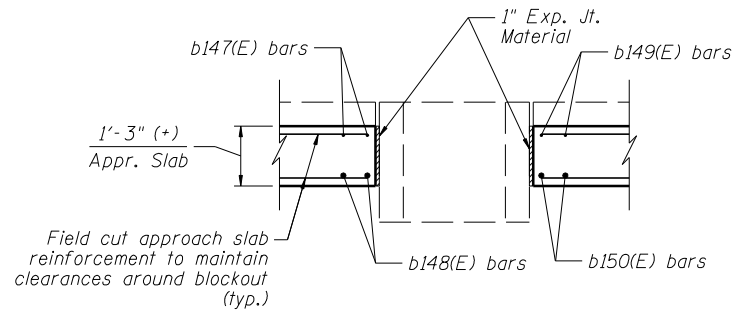

**SECTION W-W**

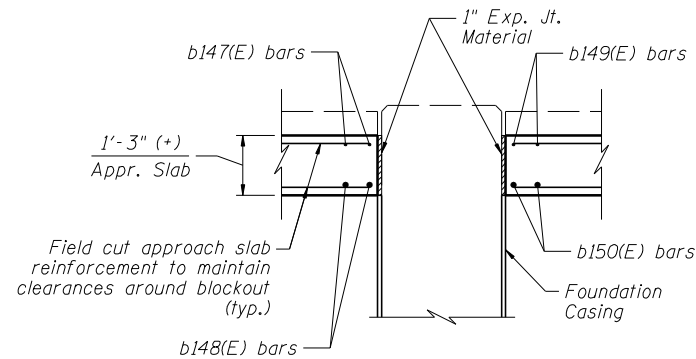

**SECTION X-X**

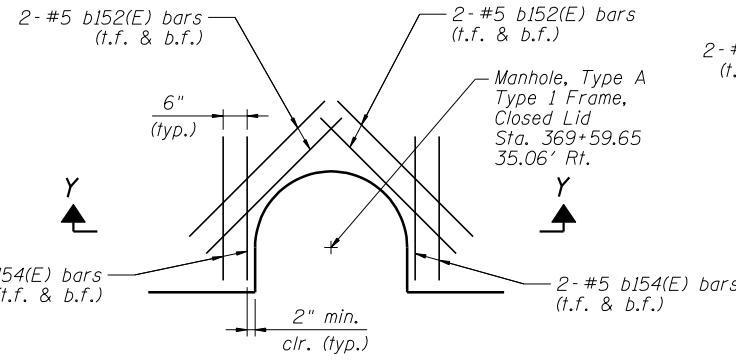

**DETAIL 2A**

Approach footing reinforcement not shown for clarity.

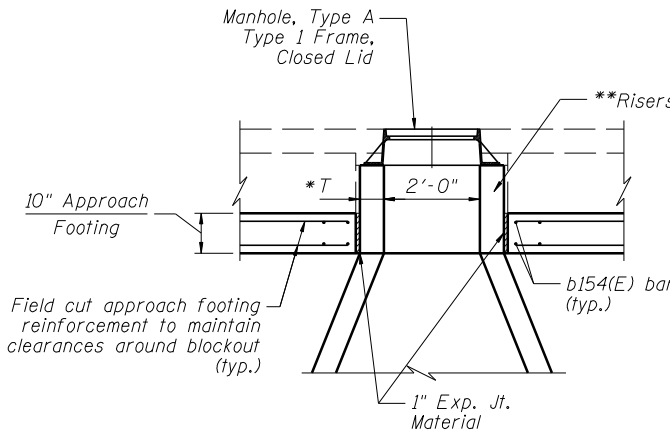

**SECTION Y-Y**

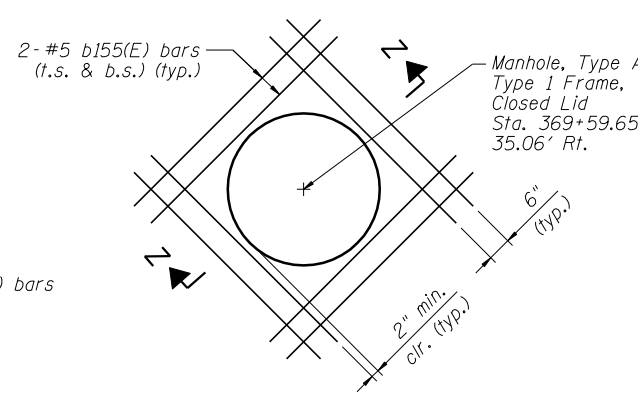

**DETAIL 2B**

Approach slab reinforcement not shown for clarity.

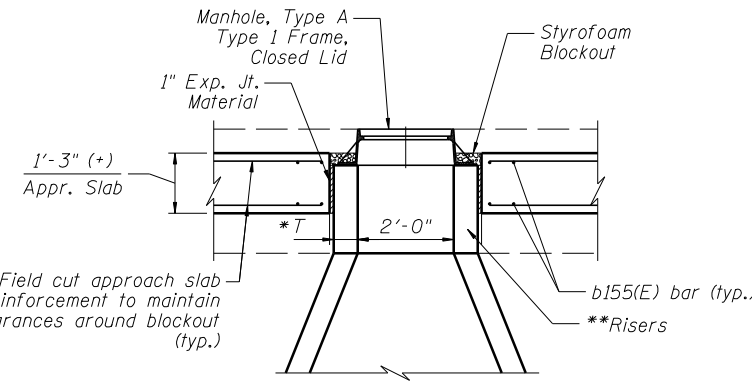

**SECTION Z-Z**

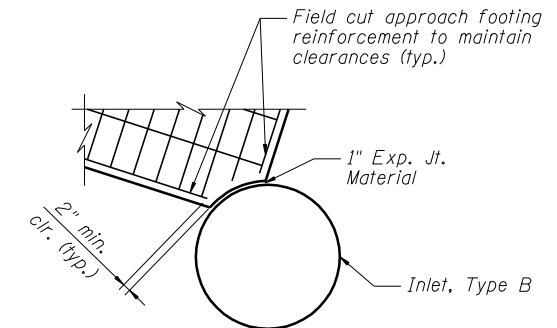

**DETAIL 3A**

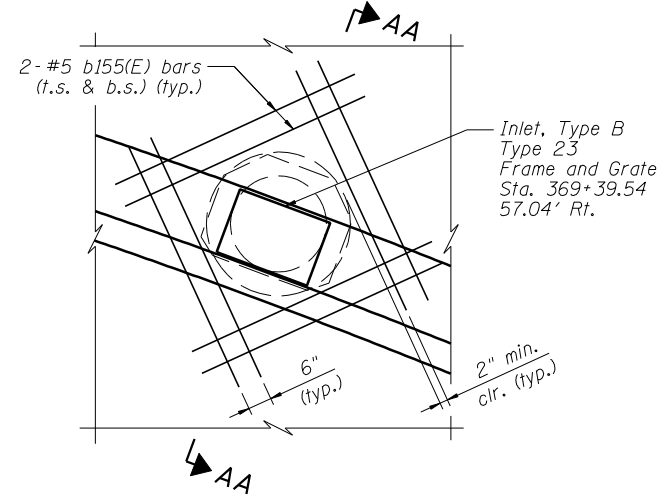

**DETAIL 3B**

Approach slab reinforcement not shown for clarity.

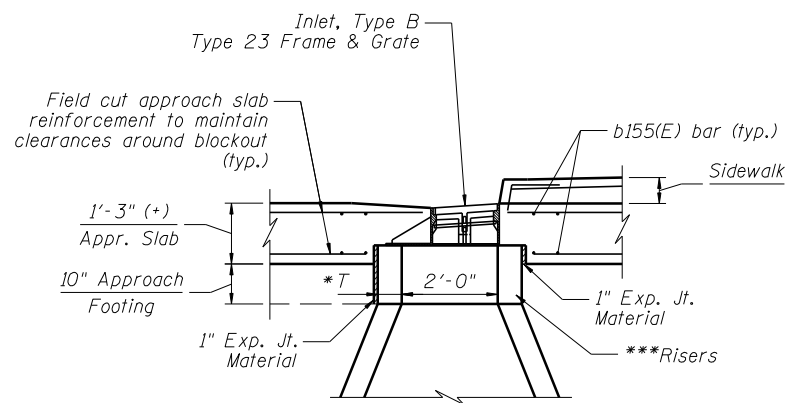

**SECTION AA-AA**

**LEGEND**

b.f. denotes bottom of footing  
t.f. denotes top of footing  
b.s. denotes bottom of slab  
t.s. denotes top of slab

\* See Std. Dwg. 602401-03 for wall thickness.  
\*\* Include cost of risers in unit price bid for Manhole, Type A.  
\*\*\* Include cost of risers in unit price bid for Inlet, Type B.



FILE NAME =	USER NAME =	DESIGNED - ASP	REVISED
		CHECKED - LNB	REVISED
		DRAWN - LNB	REVISED
		CHECKED - ASP	REVISED

**STATE OF ILLINOIS  
DEPARTMENT OF TRANSPORTATION**

**IL 2 (RT.) BIKE PATH AT 15TH AVENUE  
STAGE I BLOCKOUT DETAILS**

SHEET NO. 10 OF 18 SHEETS

F.A.P. RTE.	SECTION	COUNTY	TOTAL SHEETS	SHEET NO.
742	(32.33) R-1	WINNEBAGO	705	540
			CONTRACT NO. 64821	
ILLINOIS FED. AID PROJECT				