

DETAIL 4A

Approach footing reinforcement not shown for clarity.

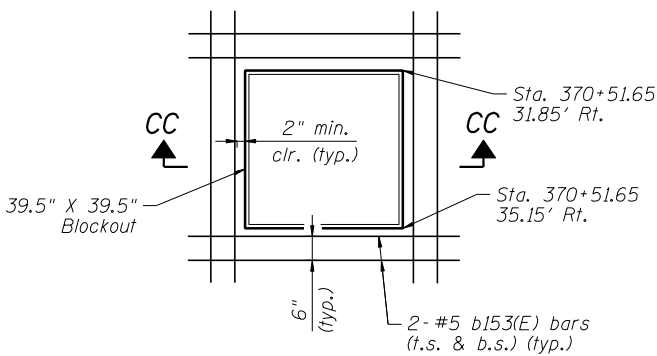

DETAIL 4B

Approach slab reinforcement not shown for clarity.

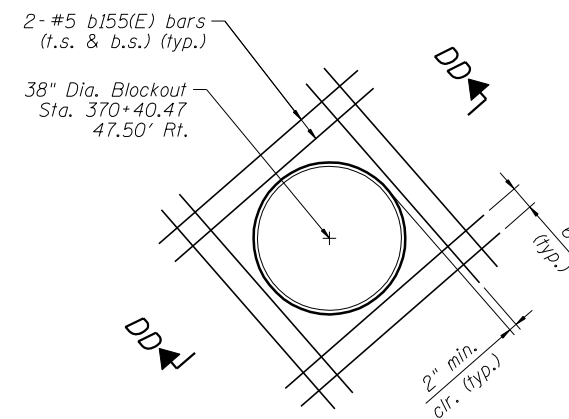

DETAIL 5A

Approach slab reinforcement not shown for clarity.

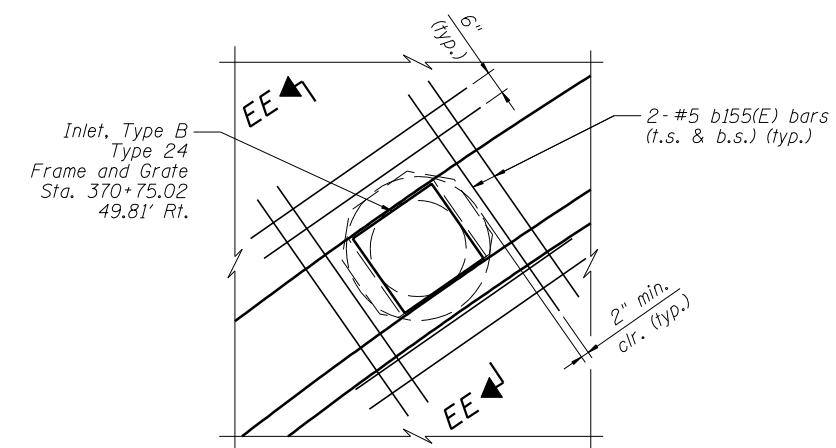

DETAIL 6

Approach slab reinforcement not shown for clarity.

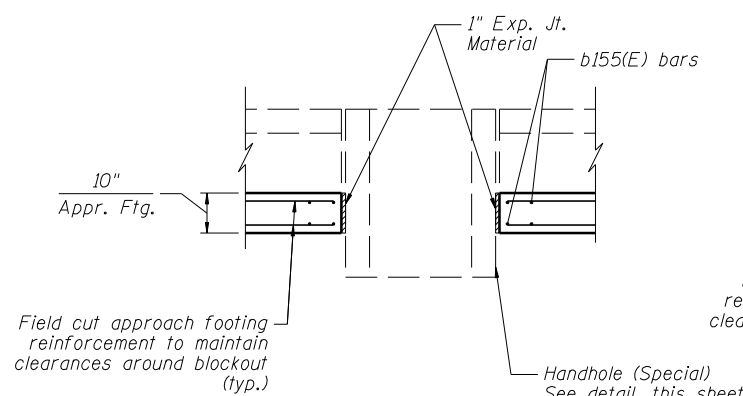

SECTION BB-BB

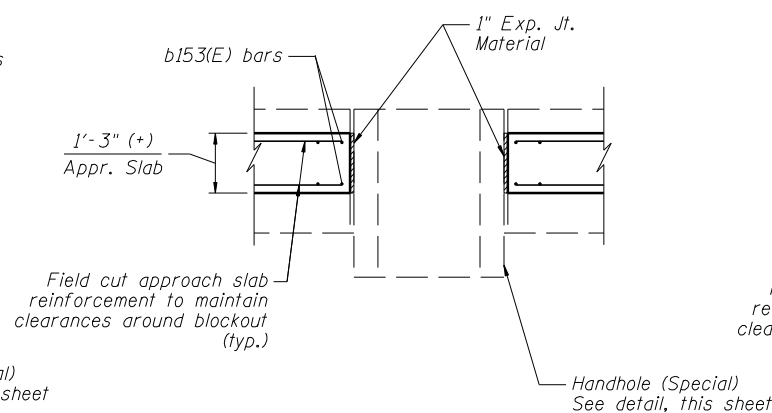

SECTION CC-CC

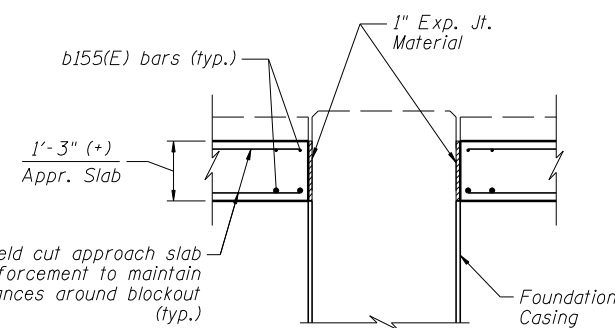

SECTION DD-DD

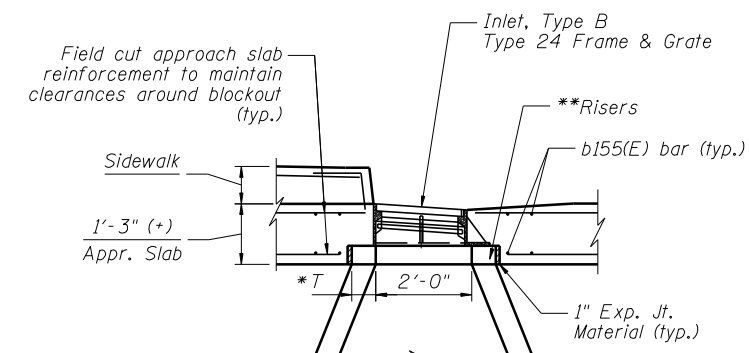

SECTION EE-EE

* See Std. Dwg. 602401-03 for wall thickness.
 ** Include cost of risers in unit price bid for Inlet, Type B.

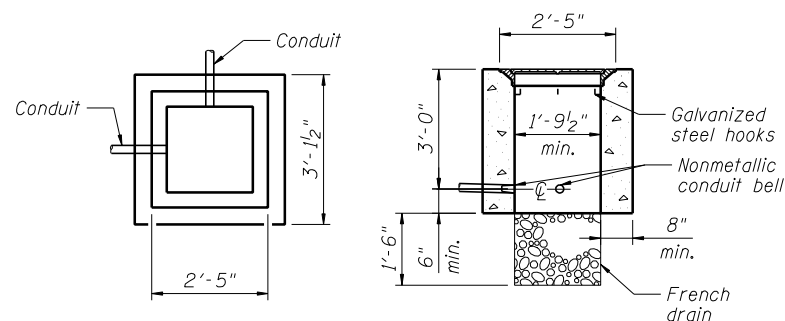

PLAN

ELEVATION

HANDHOLE (SPECIAL)

LEGEND

b.f. denotes bottom of footing
 t.f. denotes top of footing
 b.s. denotes bottom of slab
 t.s. denotes top of slab

FILE NAME = 	USER NAME =	DESIGNED - ASP	REVISED	STATE OF ILLINOIS DEPARTMENT OF TRANSPORTATION	IL 2 (RT.) BIKE PATH AT 15TH AVENUE STAGE II BLOCKOUT DETAILS	F.A.P. RTE. = 742	SECTION (32.33) R-1	COUNTY WINNEBAGO	TOTAL SHEETS 705	SHEET NO. 542
	PLOT SCALE =	CHECKED - LNB	REVISED			SHEET NO. 542				
PLOT DATE =	DRAWN - LNB	REVISED		SHEET NO. 12 OF 18 SHEETS		CONTRACT NO. 64821		ILLINOIS FED. AID PROJECT		