

**SOUTH TRAFFIC ISLAND PLAN**

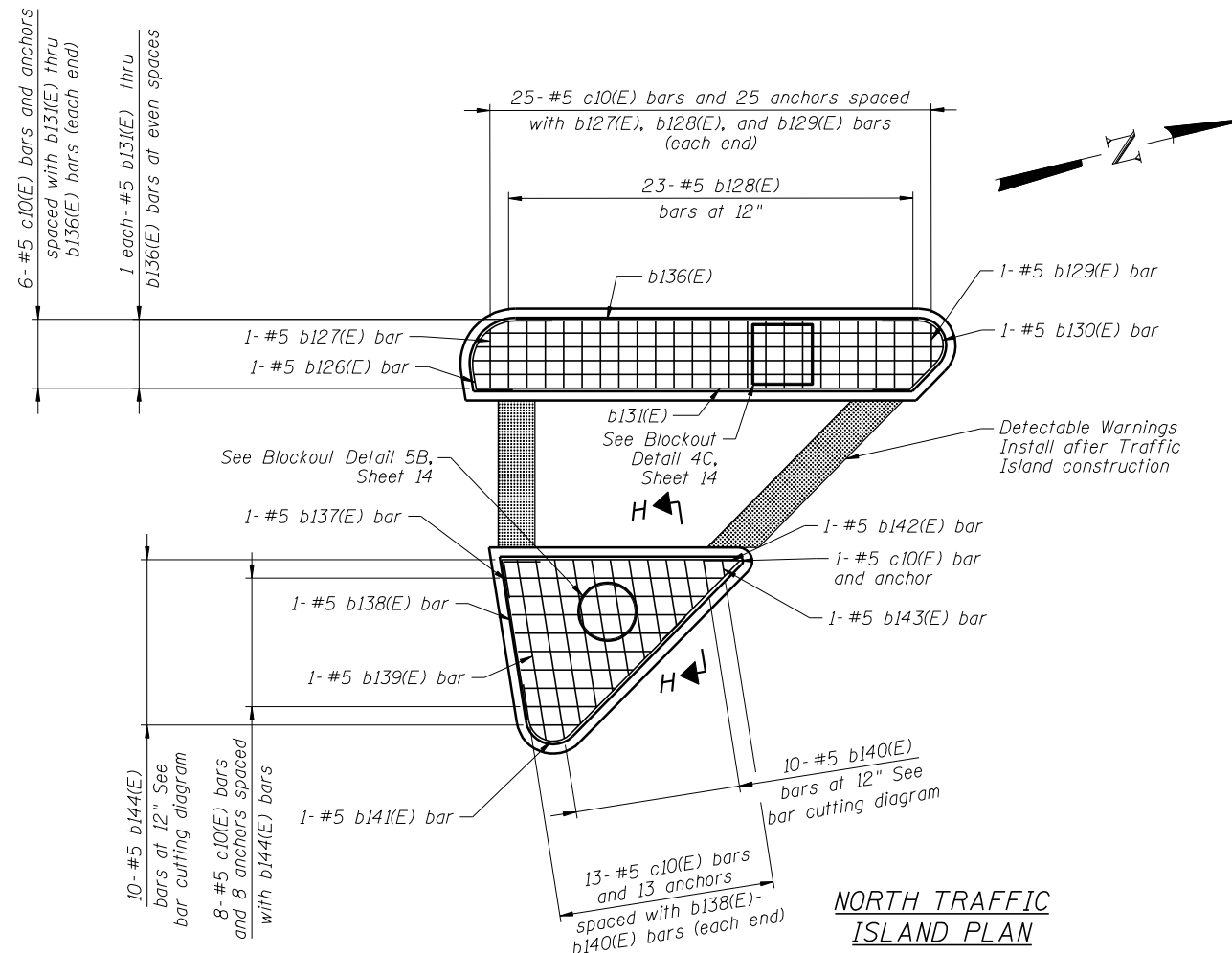

**NORTH TRAFFIC ISLAND PLAN**

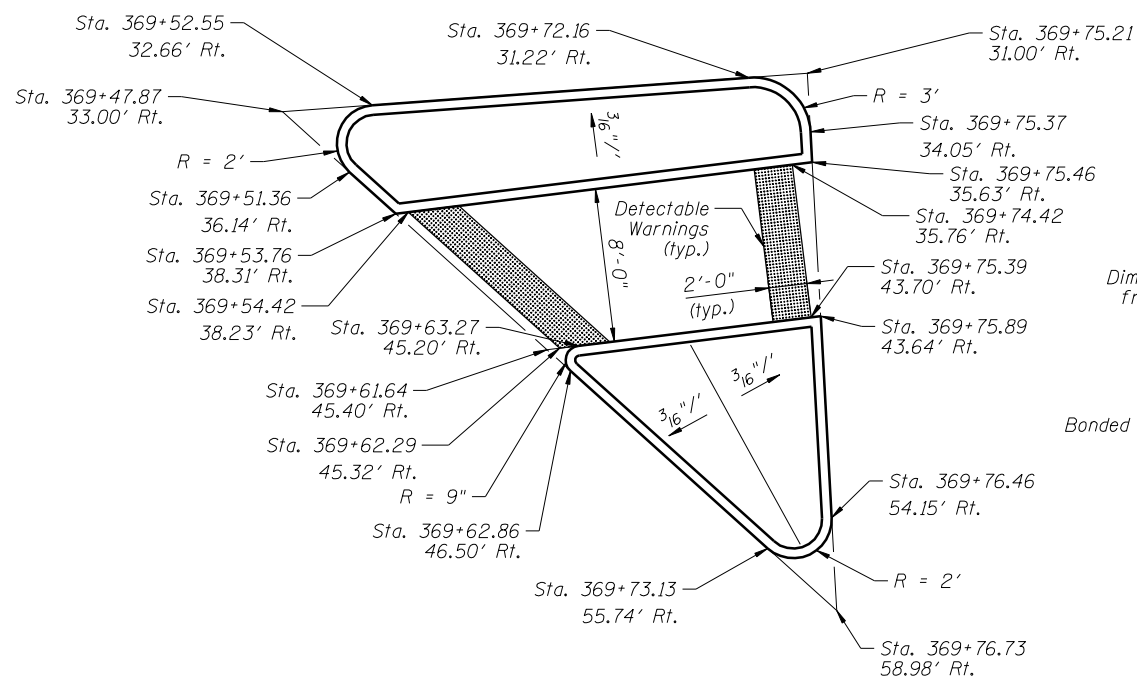

**SOUTH TRAFFIC ISLAND LAYOUT**

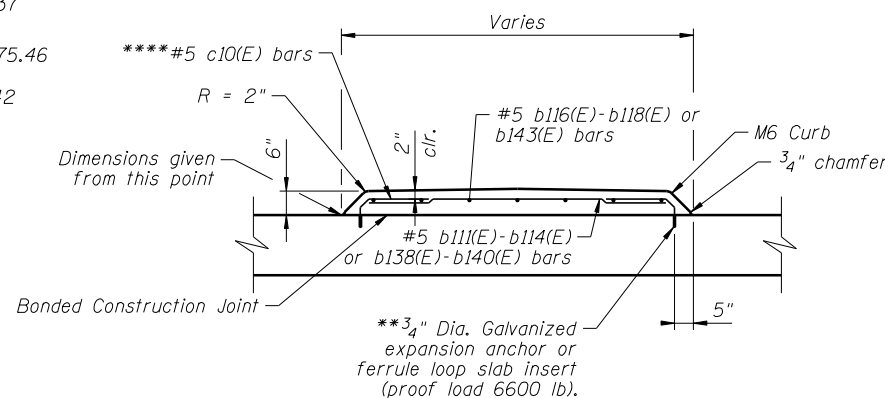

**SECTION H-H**

\*\* Install expansion anchors/inserts during Stage Construction and set top of insert flush with approach slab. The cost of expansion anchors/inserts is included in the cost of Reinforcement Bars, Epoxy Coated.

\*\*\*\* Rotate #5 c10(E) bars as required to maintain clearance.

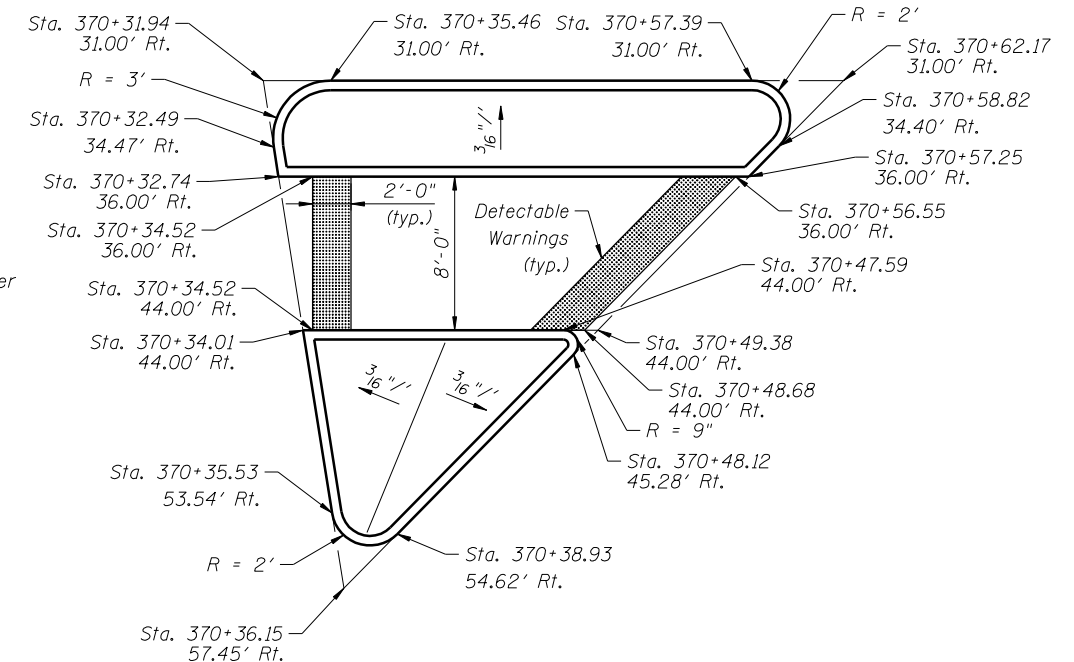

**NORTH TRAFFIC ISLAND LAYOUT**