

ENTRANCE APPROACHES – URBAN AREA

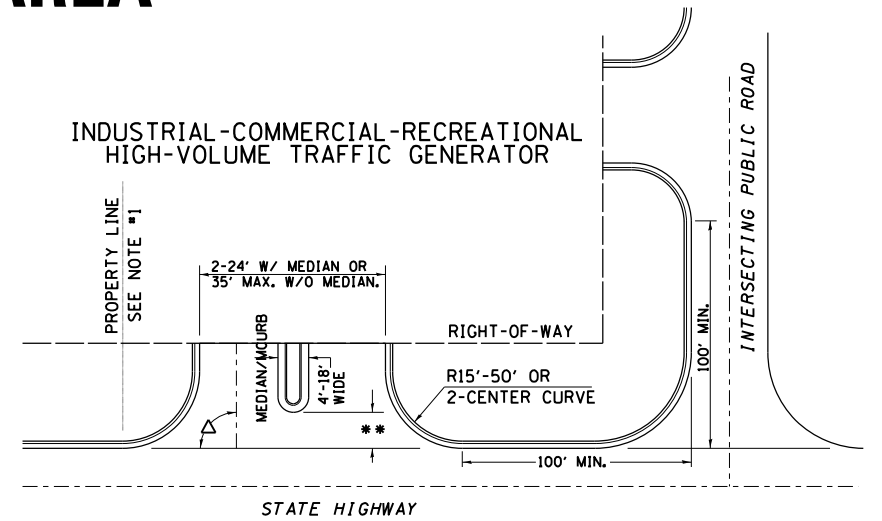
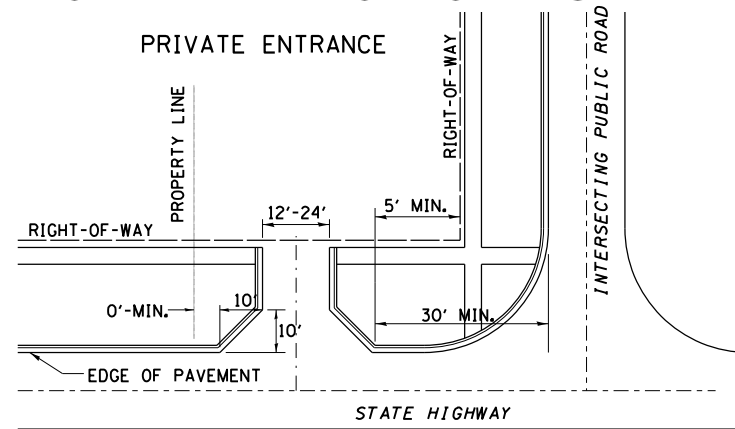
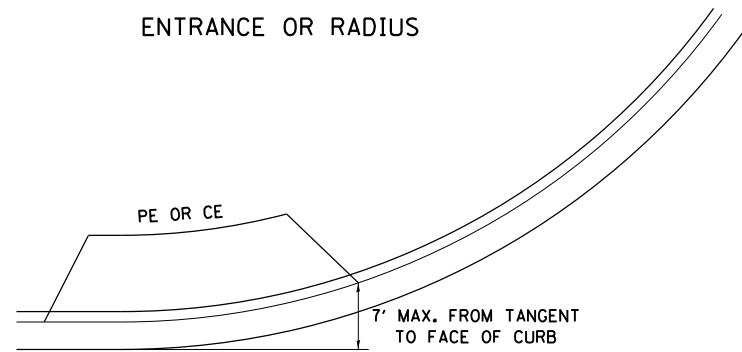

A MINIMUM OF 440 FEET SHALL BE MAINTAINED BETWEEN CENTER LINES OF ADJACENT DRIVEWAYS.
 Δ 90° DESIRABLE, 45° MIN. ANGLE PERMITTED ONLY FOR ONE-WAY DRIVEWAYS.
 60° MIN. ANGLE FOR TWO-WAY DRIVEWAYS.

NOTE: #1 ENCROACHMENT ON THE ADJACENT PROPERTY OWNER LAND REQUIRES HIS OR HER WRITTEN APPROVAL.

** 4'-10" IF HIGHWAY CURBED.
 AT EDGE OF SHOULDER IF HIGHWAY UNCURBED.

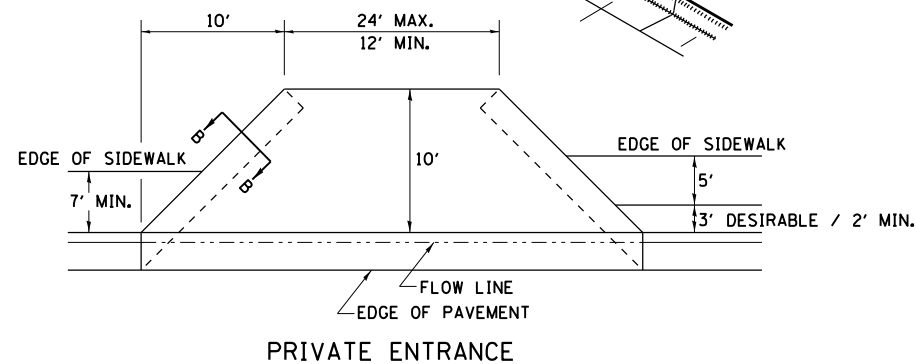
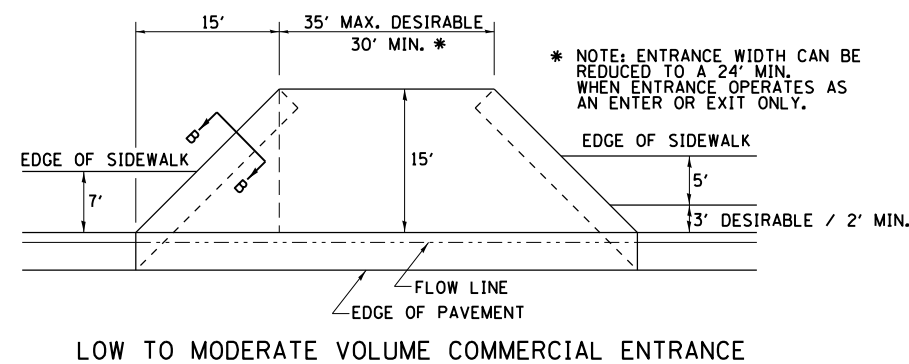
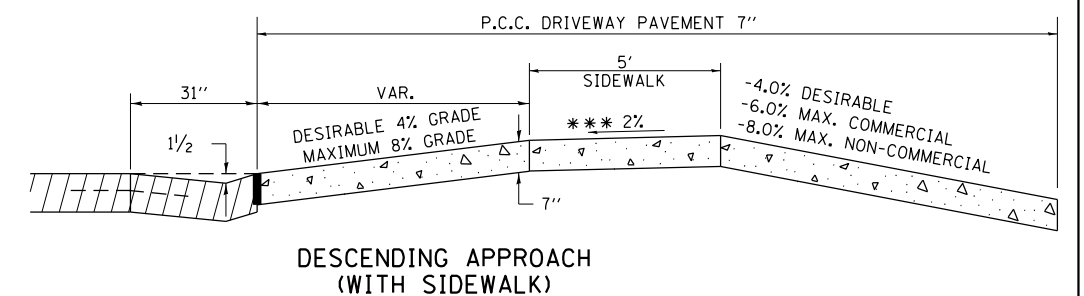
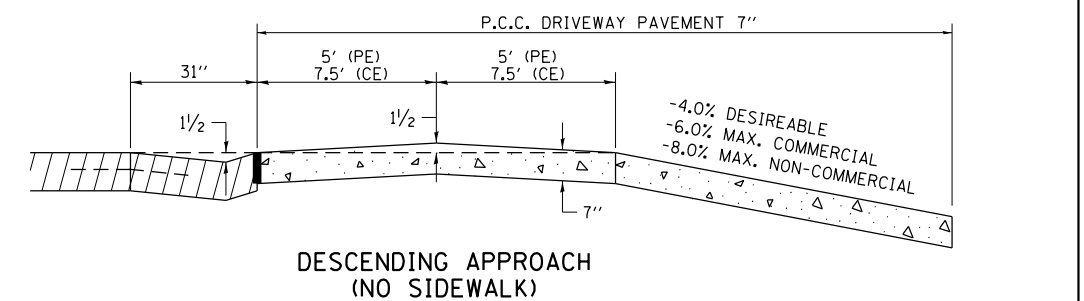
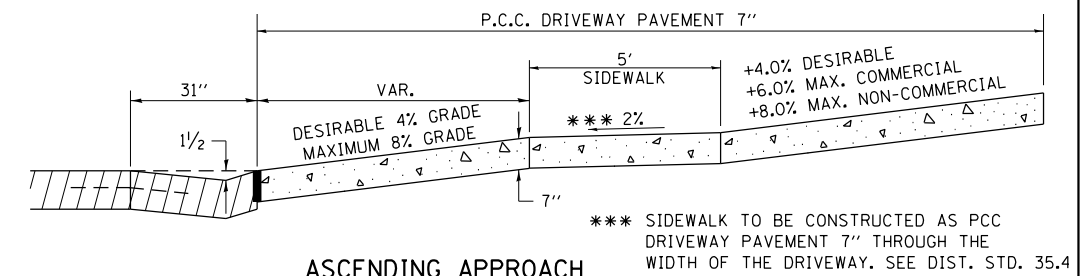
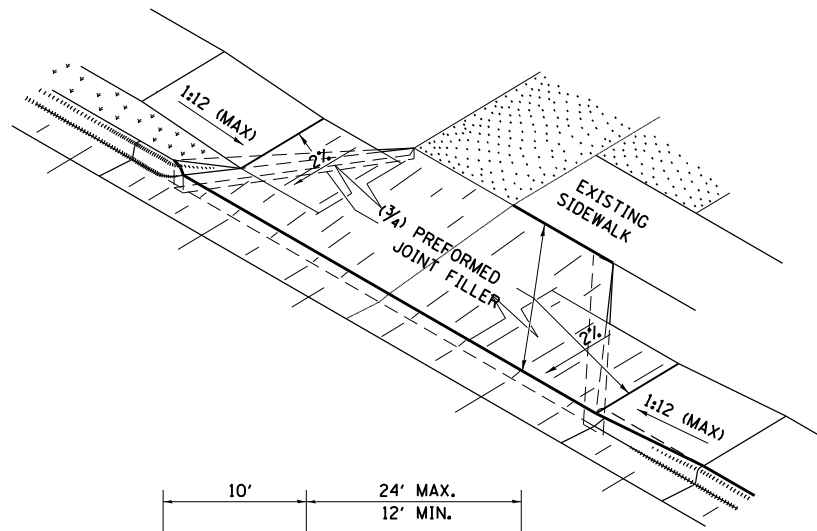
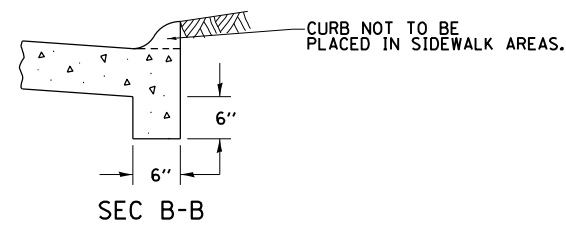

NOTE: CURVED ENTRANCE RETURNS MAY BE USED FOR LOW TO MODERATE VOLUME LOCATIONS WITH REVIEW ON A CASE-BY-CASE BASIS.

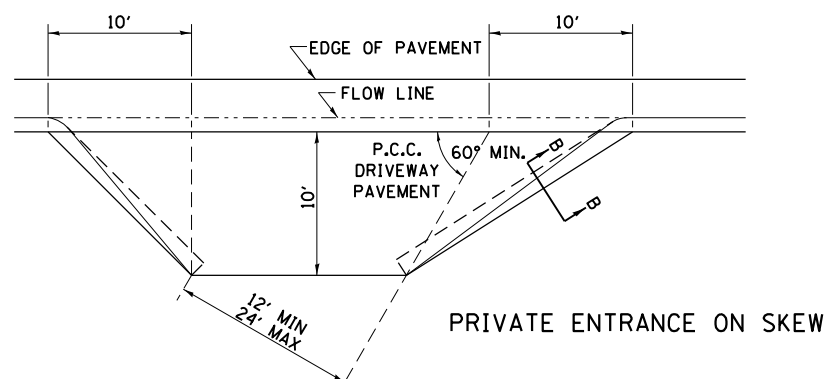
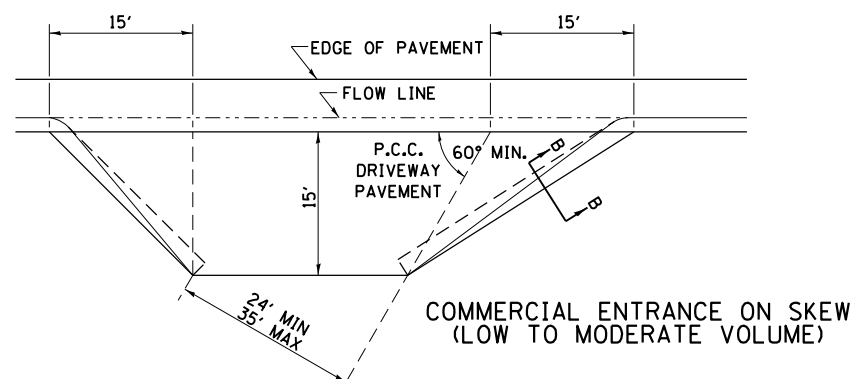

FILE NAME =	USER NAME = #USER#	DESIGNED -	REVISED - 12-07-10
#FILE#		DRAWN -	REVISED -
	PLOT SCALE = #SCALE#	CHECKED -	REVISED -
	PLOT DATE = #DATE#	DATE -	REVISED -

STATE OF ILLINOIS
DEPARTMENT OF TRANSPORTATION

REGION 2 / DISTRICT 2 STANDARD

SCALE: SHEET NO. 11 OF 19 SHEETS STA. TO STA.

F.A.P. R.T.E.	SECTION	COUNTY	TOTAL SHEETS	SHEET NO.
742	(32, 33) R-1	WINNEBAGO	705	575
CONTRACT NO. 64821				
FED. ROAD DIST. NO. ILLINOIS FED. AID PROJECT				