

ENTRANCE SIGN FOR USE WITH TEMPORARY SIGNALS

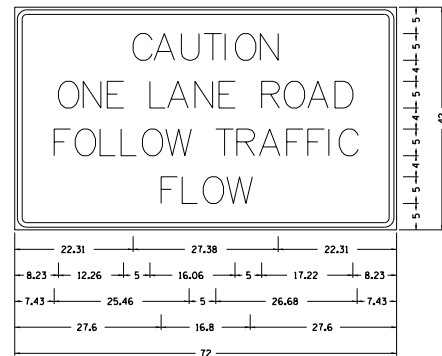

Type AA Fluorescent Orange Sheetting :
2.25" Radius, 0.88" Border, 0.50" Indent, Black on Orange
(CAUTION) D; (ONE LANE ROAD) D;
(FOLLOW TRAFFIC) D; (FLOW) D

Table Of Widths And Spaces

	C	A	U	T	I	O	N							
22.31	3.36	0.62	4.18	0.94	3.36	0.94	3.04	0.94	0.78	1.17	3.52	1.17	3.36	22.31
	O	N	E											
8.23	3.51	1.17	3.36	1.18	3.04									
	L	A	N	E										
5.00	3.05	0.31	4.18	0.94	3.36	1.17	3.05							
	R	O	A	D										
5.00	3.36	0.93	3.52	0.94	4.18	0.93	3.36	8.23						
	F	O	L	L	O	W								
7.43	3.04	0.94	3.52	1.17	3.04	0.94	3.05	0.94	3.51	0.94	4.37			
	T	R	A	F	I	C								
5.00	3.05	0.94	3.36	0.94	4.18	0.93	3.05	0.94	3.04	0.94	0.78	1.18	3.35	7.43
	F	L	O	W										
27.60	3.05	0.94	3.04	0.94	3.52	0.93	4.38	27.60						

GENERAL NOTES

THIS SIGN SHALL BE INSTALLED AT ENTRANCES LOCATED BETWEEN THE TEMPORARY SIGNALS AS DIRECTED BY THE ENGINEER.
ALL DIMENSIONS ARE IN INCHES UNLESS OTHERWISE NOTED.
THE COST TO FURNISH, INSTALL AND REMOVE THIS SIGN AT THE REQUIRED LOCATIONS SHALL BE INCLUDED IN THE COST OF TRAFFIC CONTROL AND PROTECTION STANDARD 701321.
ALL DIMENSIONS ARE IN INCHES UNLESS OTHERWISE NOTED.

REVISED - 10-14-11

ENTRANCE SIGN FOR USE WITH TEMPORARY SIGNALS 75.2

INFORMATIONAL WARNING SIGN (FOR NARROW TRAVEL LANES)

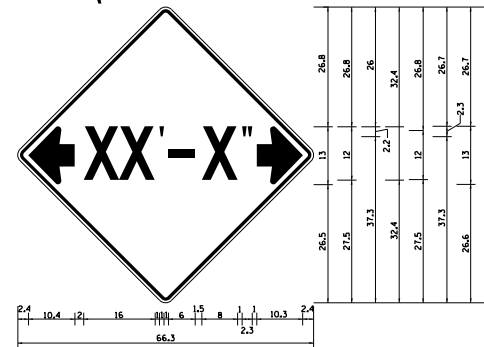

NOTES
#12-2 - Horizontal Clearance Sign
48.0" across sides, 1.9" Radius,
0.8" Border, 0.5" Indent, Black on
Orange Standard Arrow Custom
10.4" x 8.1" 180° Black 11 Inch
O Series Lettering Standard Arrow
Custom 10.4" x 8.1" O

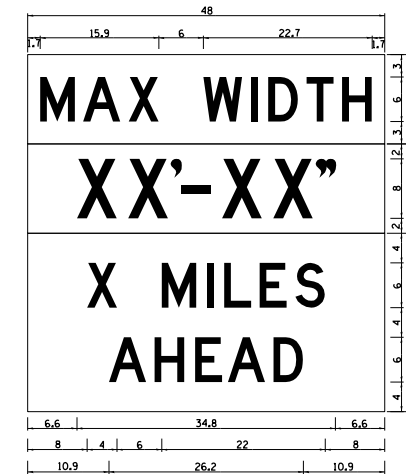

#12-1103 (Width Is 8D)
No border, Black on White;
[MAX WIDTH] D;
No border, Black on Orange;
[XX'-XX"] D;
No border, Black on White;
[X MILES] D; [AHEAD] D;

All work to furnish and install these signs shall be included in the cost of the Traffic Control Standards and shall not be paid for separately.
ALL DIMENSIONS ARE IN INCHES UNLESS OTHERWISE NOTED.

REVISED - 5-15-09

INFORMATIONAL WARNING SIGNS (FOR NARROW TRAVEL LANES) 39.2

HOT-MIX ASPHALT SHOULDER

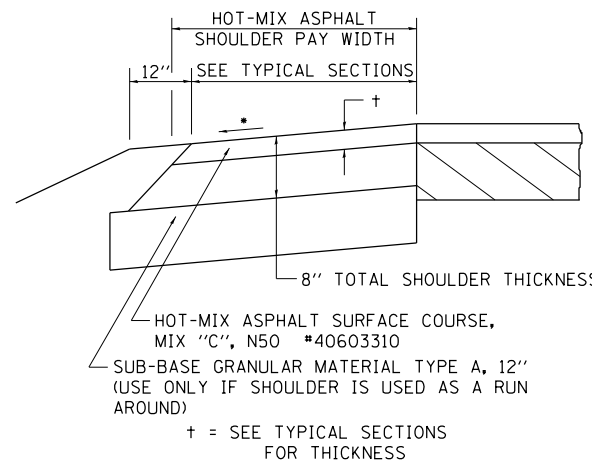

GENERAL NOTES

THE HOT-MIX ASPHALT SHOULDER SHALL BE CONSTRUCTED IN ACCORDANCE WITH SECTION 482 EXCEPT THE TOP LIFT SHALL BE HOT-MIX ASPHALT SURFACE COURSE, MIX "C", N50 #40603310. THE WORK WILL BE PAID FOR AT THE CONTRACT UNIT PRICE PER TON FOR HOT-MIX ASPHALT SURFACE COURSE, MIX "C", N50 #40603310 AND SQUARE YARD FOR HOT-MIX ASPHALT SHOULDERS OF THE THICKNESS SPECIFIED.

USE HOT-MIX ASPHALT SURFACE COURSE, MIX "C", N50 #40603310, WHEN RESURFACING EXISTING HOT-MIX ASPHALT SHOULDERS. THE THICKNESS IS SHOWN ON THE TYPICAL SECTIONS. THIS WORK WILL BE PAID FOR AT THE CONTRACT UNIT PRICE PER TON FOR HOT-MIX ASPHALT SURFACE COURSE, MIX "C", N50 #40603310.

REMOVAL OF MATERIAL FOR PLACEMENT OF THE HOT-MIX ASPHALT SHOULDER TO BE PAID FOR IN UNITS FOR EXCAVATING AND GRADING EXISTING SHOULDERS OR IN CUBIC YARDS FOR EARTH EXCAVATION OR EARTH EXCAVATION WIDENING.

* 4% WHEN MAINLINE IS ON TANGENT. FOR CROSS SLOPE ON SUPERELEVATION SECTION, SEE HIGHWAY STANDARD 482001 OR 482006.

REVISED - 7-05-12

HOT-MIX ASPHALT SHOULDER 23.4a

STOP LINE SIGN FOR TEMPORARY SIGNALS



SIZE: 24 x 24
4 CAPITAL LETTERS - BLACK
1/2 BORDER - BLACK
WHITE REFLECTIVE - TYPE AP
HIGH INTENSITY PRISMATIC SHEETING

GENERAL NOTE:

THIS SIGN SHALL BE INSTALLED AT THE STOP LINE AS DIRECTED BY ENGINEER.

ALL DIMENSIONS ARE IN INCHES UNLESS OTHERWISE NOTED.

REVISED - 10-11-11

STOP LINE SIGN FOR TEMPORARY SIGNALS 99.4

DESIGNED -		DATE -	
CHECKED -		REVISED	
DRAWN -		REVISED	
CHECKED -			

STATE OF ILLINOIS
DEPARTMENT OF TRANSPORTATION

F.A.P. RTE.	SECTION	COUNTY	TOTAL SHEETS	SHEET NO.
573	D2 BRIDGE DECK REPAIR 2013-2	LEE	22	9
				CONTRACT NO. 64H74