

When cantilever forming brackets are used, the work shall be done according to Article 503.06(b) of the Standard Specifications, except as modified below and in the details shown on this sheet.
 The finishing machine rails shall be placed on the top flange of the exterior beams.
 The beams or girders, supporting cantilever forming brackets, shall be tied together at 4 foot intervals.
 For Standard construction, or Stage Construction the Hardwood bracing materials shall be placed as shown between webs of beams in each bay.

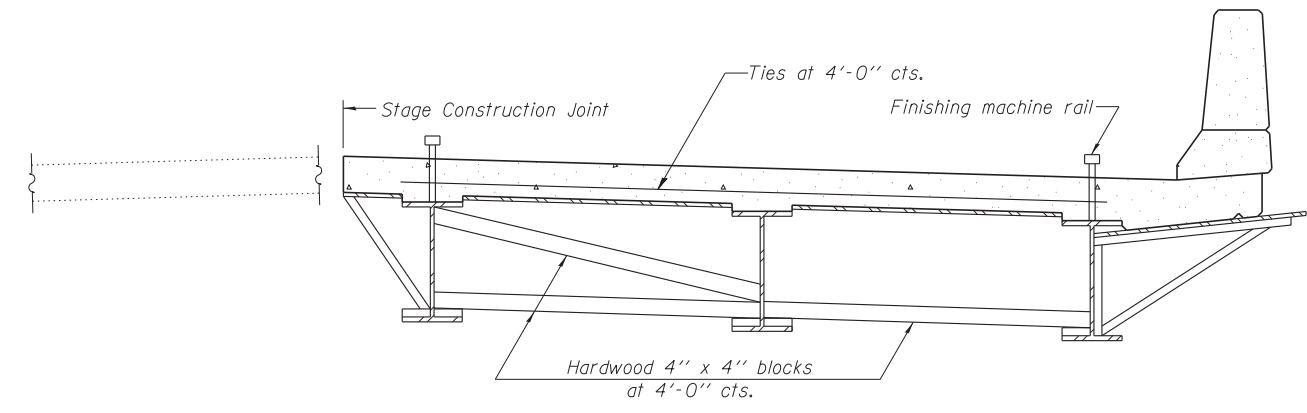

FORM BRACES FOR
STAGE CONSTRUCTION

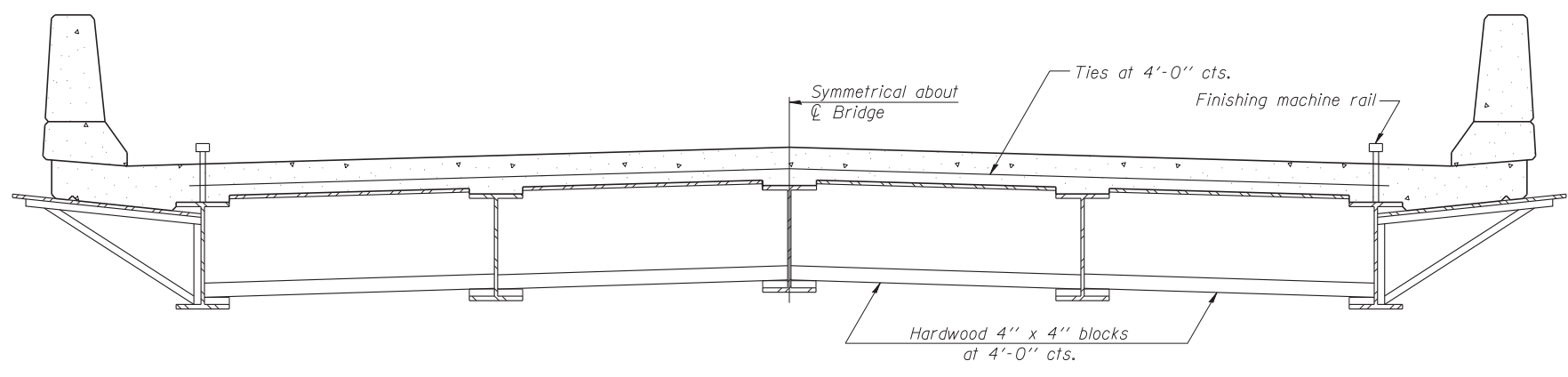

FORM BRACES FOR
STANDARD CONSTRUCTION

SB-1

7-1-10

DATES ASSOCIATES
 Engineering • Architecture
 ILLINOIS
 Eastport Business Center 1
 100 Lamar Court, Suite 1
 Cahokia, IL 62204
 tel: 618.345.2200
 fax: 618.345.2203
 www.datesassociates.com

USER NAME =	DESIGNED -	REVISED
	CHECKED -	REVISED
PLOT SCALE =	DRAWN -	REVISED
PLOT DATE =	CHECKED -	REVISED

**STATE OF ILLINOIS
DEPARTMENT OF TRANSPORTATION**

**CANTILEVER FORMING BRACKETS FOR SUPERSTRUCTURES WITH
W27 BEAMS AND SMALLER**

F.A.P. RTE.	SECTION	COUNTY	TOTAL SHEETS	SHEET NO.
681	(113 BR)BR & (113 BR-1)BR	LIVINGSTON	123	51
				CONTRACT NO. 66832

SHEET NO. 21 OF 22 SHEETS

ILLINOIS FED. AID PROJECT