



Illinois Department of Transportation

2300 South Dirksen Parkway / Springfield, Illinois / 62764

February 21, 2013

SUBJECT: FAP Route 10 (IL 111)
Project F-0010 (078)
Section 129RS-4
Madison County
Contract No. 76F26
Item No. 103, March 8, 2013 Letting
Addendum A

NOTICE TO PROSPECTIVE BIDDERS:

Attached is an addendum to the plans or proposal. This addendum involves revised and/or added material.

1. Replaced the Schedule of Prices.
2. Revised sheets 6, 10, 11, 12 and 13 of the Foldup Plans.

Prime contractors must utilize the enclosed material when preparing their bid and must include any Schedule of Prices changes in their bidding proposal.

Bidders using computer-generated bids are cautioned to reflect any and all Schedule of Prices changes, if involved, into their computer programs.

Very truly yours,

John D. Baranzelli, P. E.
Acting Engineer of Design and Environment

A handwritten signature in cursive script, reading "Ted B. Walschleger P.E.".

By: Ted B. Walschleger, P. E.
Engineer of Project Management

cc: Jeff Keirn, Region 5, District 8; Mike Renner; Estimates

dp

ILLINOIS DEPARTMENT OF TRANSPORTATION
 SCHEDULE OF PRICES
 CONTRACT
 NUMBER - 76F26

State Job # - C-98-017-12

County Name - MADISON -
 Code - 119 - -
 District - 8 - -
 Section Number - 129RS-4

Project Number
 F-0010/078/

Route
 FAP 10

* REVISED: FEBRUARY 20, 2013

Item Number	Pay Item Description	Unit of Measure	Quantity	x	Unit Price	=	Total Price
40200800	AGG SURF CSE B	TON	8.000				
40300200	BIT MATLS PR CT	TON	11.700				
40600300	AGG PR CT	TON	57.000				
40600982	HMA SURF REM BUTT JT	SQ YD	222.000				
40600990	TEMPORARY RAMP	SQ YD	186.000				
40603340	HMA SC "D" N70	TON	2,619.000				
40800050	INCIDENTAL HMA SURF	TON	23.000				
44000152	HMA SURF REM 3/4	SQ YD	36,740.000				
44201827	CL D PATCH T2 15	SQ YD	86.000				
44300200	STRIP REF CR CON TR	FOOT	21,466.000				
48102100	AGG WEDGE SHLD TYPE B	TON	261.000				
*REV 48203100	HMA SHOULDERS	TON	600.000				
67000400	ENGR FIELD OFFICE A	CAL MO	4.000				
67100100	MOBILIZATION	L SUM	1.000				
70100450	TRAF CONT-PROT 701201	L SUM	1.000				

ILLINOIS DEPARTMENT OF TRANSPORTATION
 SCHEDULE OF PRICES
 CONTRACT
 NUMBER - 76F26

State Job # - C-98-017-12

County Name - MADISON -

Code - 119 - -

District - 8 - -

Section Number - 129RS-4

Project Number
 F-0010/078/

Route
 FAP 10

* REVISED: FEBRUARY 20, 2013

Item Number	Pay Item Description	Unit of Measure	Quantity	x	Unit Price	=	Total Price
70100460	TRAF CONT-PROT 701306	L SUM	1.000				
70100600	TRAF CONT-PROT 701336	L SUM	1.000				
70300100	SHORT TERM PAVT MKING	FOOT	2,450.000				
70300210	TEMP PVT MK LTR & SYM	SQ FT	32.000				
70300220	TEMP PVT MK LINE 4	FOOT	31,901.000				
70300260	TEMP PVT MK LINE 12	FOOT	172.000				
70301000	WORK ZONE PAVT MK REM	SQ FT	817.000				
78000100	THPL PVT MK LTR & SYM	SQ FT	32.000				
78000200	THPL PVT MK LINE 4	FOOT	31,901.000				
78000600	THPL PVT MK LINE 12	FOOT	172.000				
78100100	RAISED REFL PAVT MKR	EACH	198.000				
78300200	RAISED REF PVT MK REM	EACH	198.000				

DATE
 12/14/2012
 c:\pwwork\pwwork\intel\menyl\08280730\0876126-sht-pln.dgn

SUMMARY OF QUANTITIES

CODE NO	ITEM	UNIT	URBAN TOTAL QUANTITIES	BO% FED. 0005 20% ST.	CONSTRUCTION TYPE CODE
40200800	AGGREGATE SURFACE COURSE, TYPE B	TON	8	8	
40300200	BITUMINOUS MATERIALS (PRIME COAT)	TON	11.7	11.7	
40600300	AGGREGATE (PRIME COAT)	TON	57	57	
40600982	HOT-MIX ASPHALT SURFACE REMOVAL - BUTT JOINT	SO YD	222	222	
40600990	TEMPORARY RAMP	SO YD	186	186	
40603340	HOT-MIX ASPHALT SURFACE COURSE, MIX "D", N70	TON	2619	2619	
40800050	INCIDENTAL HOT-MIX ASPHALT SURFACING	TON	23	23	
44000152	HOT-MIX ASPHALT SURFACE REMOVAL, 3/4"	SO YD	36740	36740	
44201827	CLASS D PATCHES, TYPE II, 15 INCH	SO YD	86	86	
44300200	STRIP REFLECTIVE CRACK CONTROL TREATMENT	FOOT	21466	21466	
48102100	AGGREGATE WEDGE SHOULDER, TYPE B	TON	261	261	
48203100	HOT-MIX ASPHALT SHOULDERS	TON	600	600	
67000400	ENGINEER'S FIELD OFFICE, TYPE A	CAL MO	4	4	

TOTAL SHEETS	SHEET NO.
24	6
CONTRACT NO. 76F26	



REVISED 2-20-13

SUMMARY OF QUANTITIES

 F.A.P. ROUTE 10
 SECTION 129RS-3
 MADISON COUNTIES

 PLOT DATE: 12/14/2012

TOTAL SHEETS	SHEET NO.
24	10
CONTRACT NO.: 76F26	

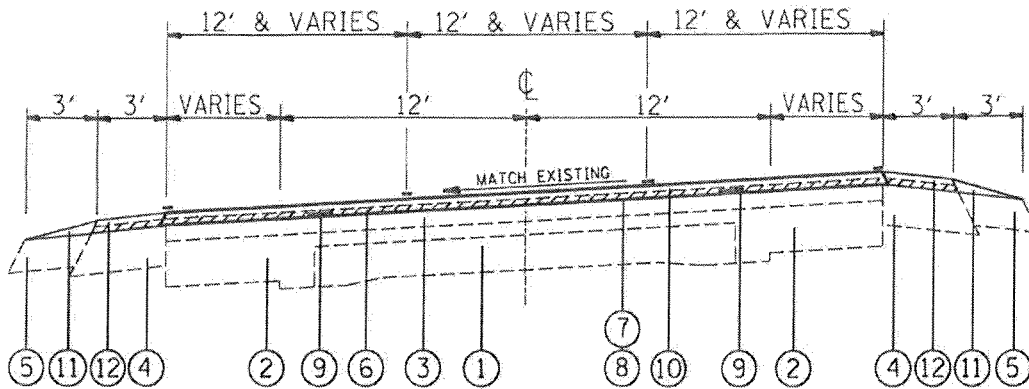

TYPICAL SECTION (IL 111)

M.P. 0.00 TO M.P. 0.15

LEGEND

- ① EXISTING CONCRETE PAVEMENT 9-6-9
- ② EXISTING HMA WIDENING
- ③ EXISTING HMA RESURFACING
- ④ EXISTING HMA SHOULDER
- ⑤ EXISTING AGGREGATE SHOULDERS
- ⑥ PROPOSED HMA SURFACE REMOVAL 3/4"
- ⑦ PROPOSED BITUMINOUS MATERIALS (PRIME COAT)
- ⑧ PROPOSED AGGREGATE (PRIME COAT)
- ⑨ PROPOSED STRIP REFLECTIVE CRACK CONTROL
- ⑩ PROPOSED HMA SURFACE COURSE, 1 1/2"
- ⑪ PROPOSED AGGREGATE WEDGE SHOULDER, TYPE B
- ⑫ PROPOSED HMA SHOULDER, 1 1/2"

TYPICAL SECTIONS

F.A.P. ROUTE 10
SECTION 129RS-4
MADISON COUNTY

△ REVISED SHEET 2/20/13

PLOT DATE: 2/19/2013

TOTAL SHEETS	SHEET NO.
24	11
CONTRACT NO.: 76F26	

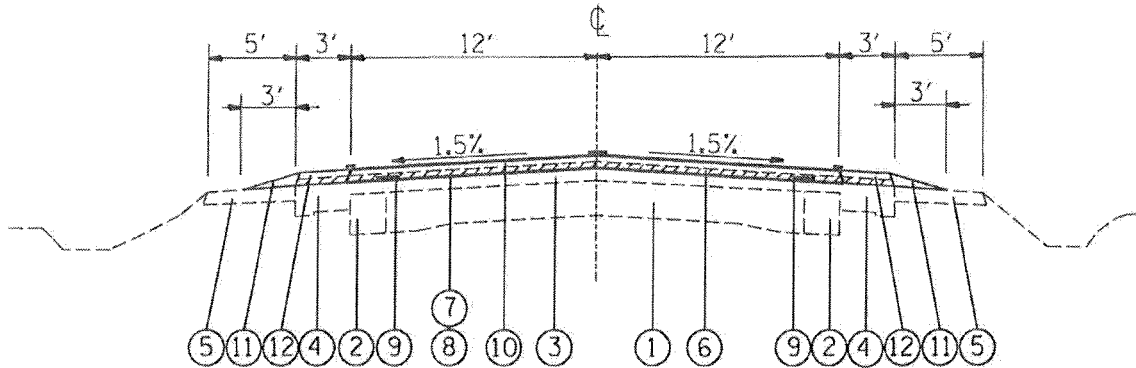

TYPICAL SECTION (IL 111)

M.P. 0.26 TO M.P. 0.28

M.P. 0.45 TO M.P. 2.03

LEGEND

- ① EXISTING CONCRETE PAVEMENT 9-6-9
- ② EXISTING HMA WIDENING
- ③ EXISTING HMA RESURFACING
- ④ EXISTING HMA SHOULDER
- ⑤ EXISTING AGGREGATE SHOULDERS
- ⑥ PROPOSED HMA SURFACE REMOVAL 3/4"
- ⑦ PROPOSED BITUMINOUS MATERIALS (PRIME COAT)
- ⑧ PROPOSED AGGREGATE (PRIME COAT)
- ⑨ PROPOSED STRIP REFLECTIVE CRACK CONTROL
- ⑩ PROPOSED HMA SURFACE COURSE, 1 1/2"
- ⑪ PROPOSED AGGREGATE WEDGE SHOULDER, TYPE B
- ⑫ PROPOSED HMA SHOULDER, 1 1/2"

TYPICAL SECTIONS

F.A.P. ROUTE 10
SECTION 129RS-4
MADISON COUNTY

△ REVISED SHEET 2/20/13

PLOT DATE: 2/19/2013

TOTAL SHEETS	SHEET NO.
24	12
CONTRACT NO.: 76F26	

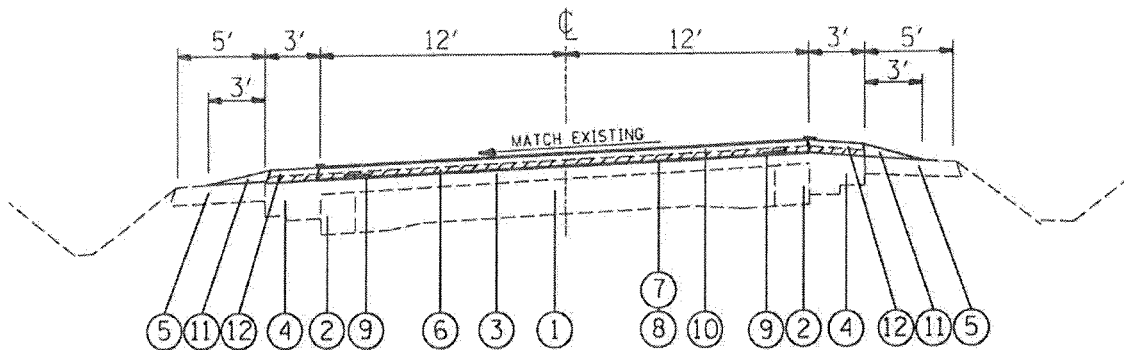

TYPICAL SECTION (IL 111)

M.P. 0.15 TO M.P. 0.26
M.P. 0.28 TO M.P. 0.45

LEGEND

- ① EXISTING CONCRETE PAVEMENT 9-6-9
- ② EXISTING HMA WIDENING
- ③ EXISTING HMA RESURFACING
- ④ EXISTING HMA SHOULDER
- ⑤ EXISTING AGGREGATE SHOULDERS
- ⑥ PROPOSED HMA SURFACE REMOVAL 3/4"
- ⑦ PROPOSED BITUMINOUS MATERIALS (PRIME COAT)
- ⑧ PROPOSED AGGREGATE (PRIME COAT)
- ⑨ PROPOSED STRIP REFLECTIVE CRACK CONTROL
- ⑩ PROPOSED HMA SURFACE COURSE, 1 1/2"
- ⑪ PROPOSED AGGREGATE WEDGE SHOULDER, TYPE B
- ⑫ PROPOSED HMA SHOULDER, 1 1/2"

TYPICAL SECTIONS

F.A.P. ROUTE 10
SECTION 129RS-4
MADISON COUNTY

⚠ REVISSED SHEET 2/20/13

PLOT DATE: 2/19/2013

TOTAL SHEETS	SHEET NO.
24	13
CONTRACT NO. 76F26	

MAINLINE RESURFACING SCHEDULE

LOCATION			HMA SURFACE REMOVAL, 3/4"	BIT. MAT'L (PRIME COAT)	AGGREGATE (PRIME COAT)	HMA SURFACE COURSE, 1.5"	STRIP REFLECTIVE CRACK CONTROL
			(SQ YD)	(TON)	(TON)	(TON)	(FOOT)
0.00	TO	0.04	877.78	0.27	1.32	62.53	400.00
0.04	TO	0.11	1946.00	0.61	2.92	101.19	834.00
0.11	TO	0.17	1180.00	0.37	1.77	71.59	590.00
0.17	TO	1.00	14608.00	4.57	21.91	1063.46	8764.80
1.00	TO	2.03	18128.00	5.67	27.19	1319.72	10876.80
TOTAL			36740	11.5	55	2619	21466

SHOULDER SCHEDULE

LOCATION			HMA SHOULDERS	AGGREGATE WEDGE SHOULDER, TYPE B
M.P.	to	M.P.	(TON)	(TON)
0.00	TO	0.19	56.18	24.38
0.19	TO	1.00	239.50	103.94
1.00	TO	2.03	304.55	132.18
TOTAL			600	261

SCHEDULES

F.A.P. ROUTE 10
SECTION 129RS-4
MADISON COUNTY

⚠ REVISIED SHEET 2/20/13

PLOT DATE: 2/19/2013