

INSIDE ELEVATION OF PARAPET

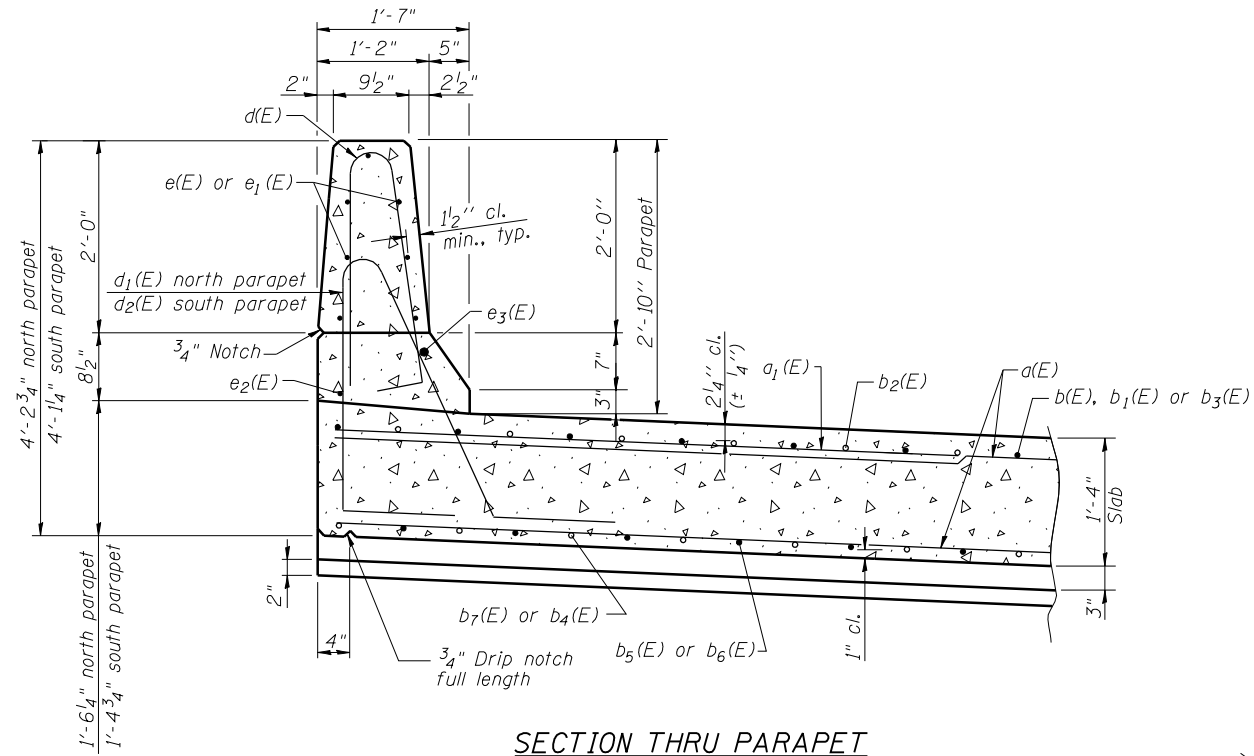

SECTION THRU PARAPET

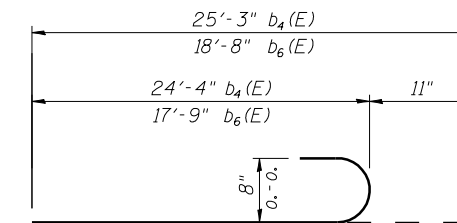
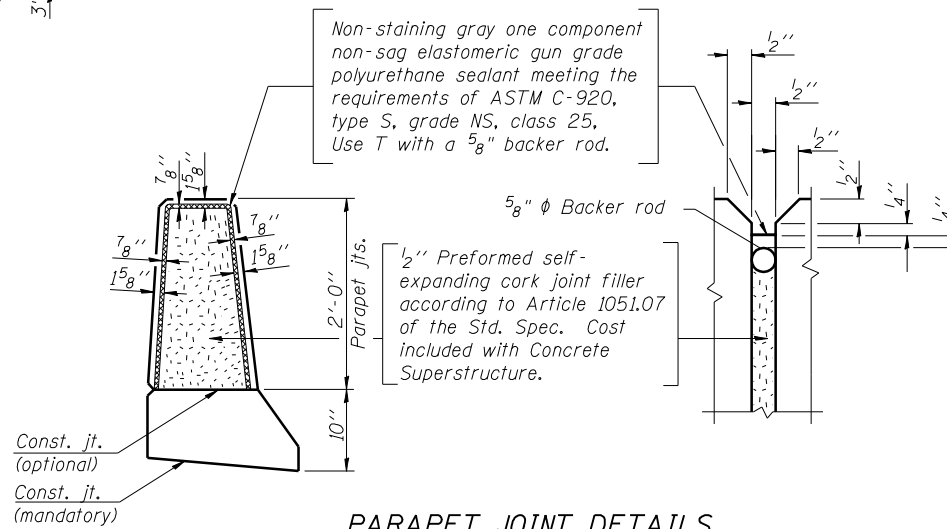

BARS b₄(E) & b₆(E)

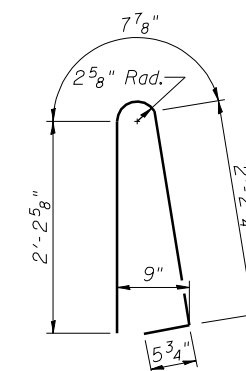

BAR d(E)

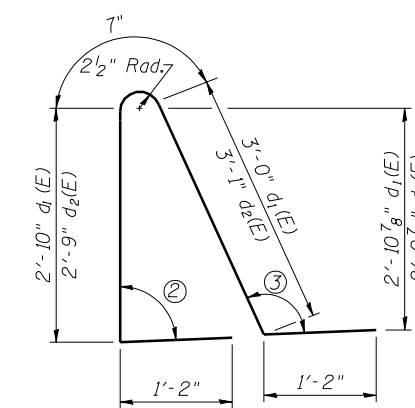

BARS d₁(E) & d₂(E)

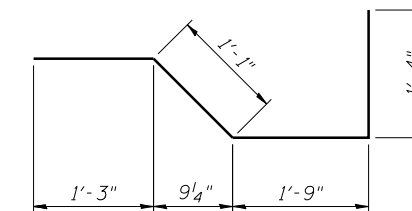

BAR x₁(E)

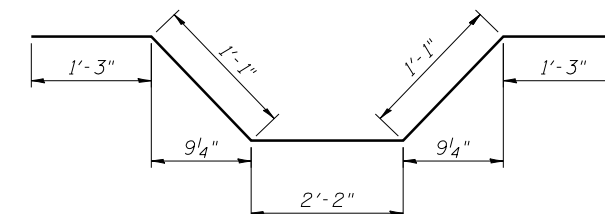

BAR x(E)

PRINT DRIVER = L:\05-ESCA\B\11
SCALE NAME = PLOT
FILE NAME = 097078-0184-09-STR-01.dwg



USER NAME = has	DESIGNED - SHL/ELH 07/12	REVISED -
ESCA PROJECT NO. 988.11	CHECKED - RDP 10/12	REVISED -
PLOT SCALE = 0/2' = 1/4" / IN.	DRAWN - HAS 07/12	REVISED -
PLOT DATE = 10/31/2012 7:14:43 AM	CHECKED - SHL 10/12	REVISED -

STATE OF ILLINOIS
DEPARTMENT OF TRANSPORTATION

SUPERSTRUCTURE DETAILS
STRUCTURE NO. 097-0078

SHEET NO. 9 OF 23 SHEETS

F.A.P. RTE.	SECTION	COUNTY	TOTAL SHEETS	SHEET NO.
332	4B-1	WHITE	70	30
CONTRACT NO. 78154				
ILLINOIS FED. AID PROJECT AID				