

ROUTE	SECTION	COUNTY	TOTAL SHEETS	SHEET NO.
TR 44	11-01164-00-BR	ALEXANDER	12	11
PROJECT NO. BROS-0003(126)			CONTRACT NO. 99461	

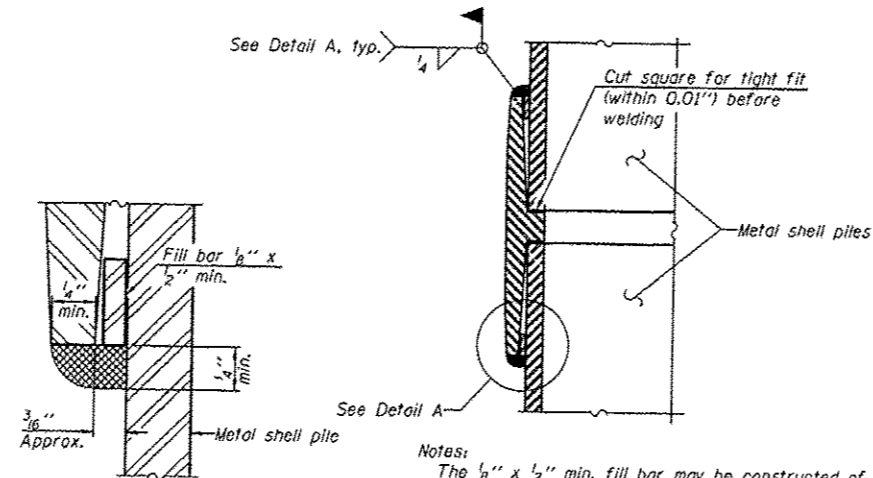

METAL SHELL PILE TABLE

Designation and outside diameter	Wall thickness t	Weight per foot (Lbs./ft.)	Inside volume (yd. ³ /ft.)
PP12	0.179"	22.60	0.0274
PP12	0.250"	31.37	0.0267
PP14	0.250"	36.71	0.0368
PP14	0.312"	45.61	0.0361



Notes:
 The $\frac{1}{8}$ " x $\frac{1}{2}$ " min. fill bar may be constructed of 2 bars with a $\frac{1}{8}$ " max. gap between them.
 Pile segments shall be driven to solid contact with splicer before welding.

WELDED COMMERCIAL SPLICE

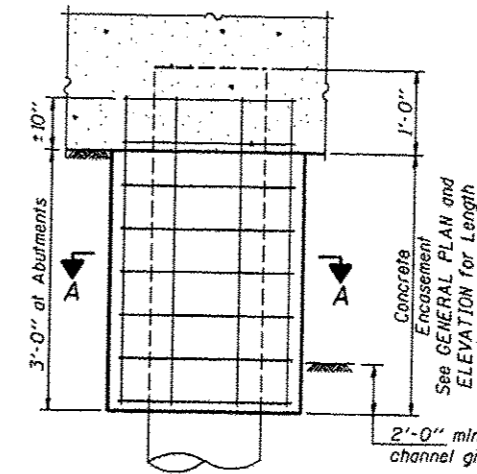

ELEVATION

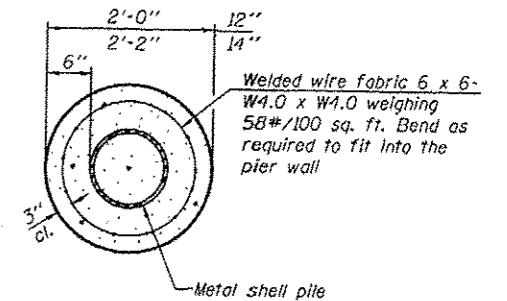

SECTION A-A

Concrete Encasement	
Pile Size	Quantity / Ft.
12" Dia.	0.087 C.Y.
14" Dia.	0.107 C.Y.

Note:
 Forms for encasement may be omitted when soil conditions permit.

CONCRETE ENCASEMENT

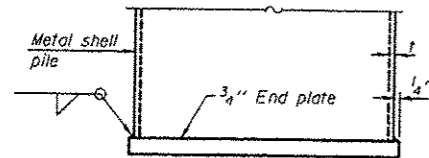

END PLATE ATTACHMENT

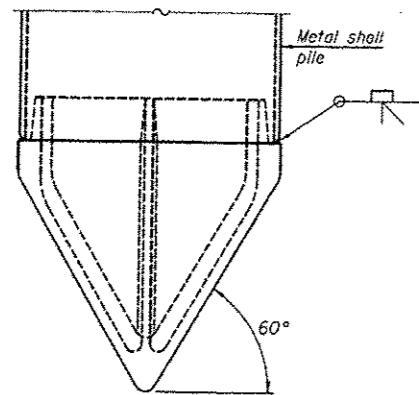

METAL SHELL PILE SHOE ATTACHMENT

(See Note A)

Note A:
 When called for on the plans, the Contractor shall furnish metal shell pile shoes consisting of a single piece conical pile point as shown. The pile shoes shall be cast in one piece steel according to either ASTM A 148 Grade 90-60 or AASHTO M 103 Grade 65-35 and shall provide full bearing over the full circumference of the metal shell pile. The pile shoe shall have tapered leads to assure proper alignment and fitting and shall be secured to the pile with a circumferential weld.

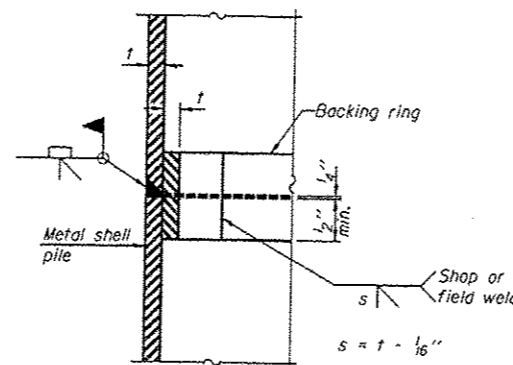

COMPLETE PENETRATION WELD SPLICE

Backing ring made from pile shell. Remove segment to allow reducing circumference and vertically rejoin with partial joint penetration weld.

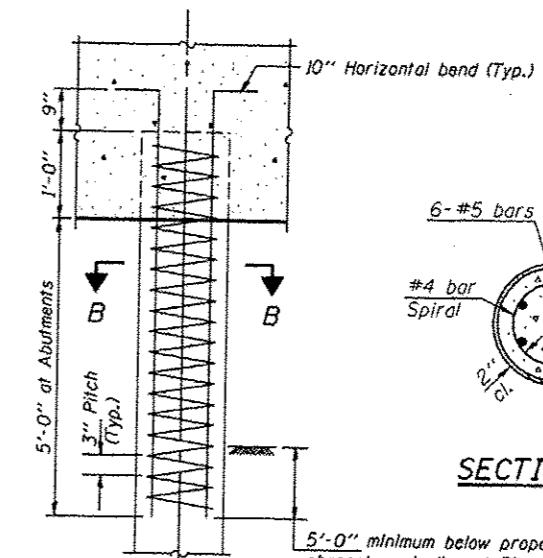

ELEVATION

METAL SHELL REINFORCEMENT

Reinforcement cage shall be omitted when Concrete Encasement is provided.

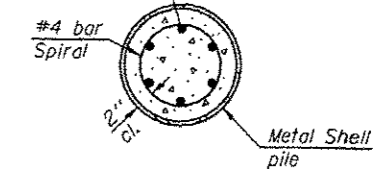

SECTION B-B

The cost of Reinforcement is included with the Cost of Furnishing Piles.

Note:
 The metal shell piles shall be according to ASTM A 252 Grade 3.

PILING DETAILS
 TOWNSHIP ROUTE 44 (TWENTE CROSSING ROAD)
 TRIBUTARY TO CIRCLE DITCH
 SECTION 11-01164-00-BR
 ALEXANDER COUNTY
 STRUCTURE NO. 002-3110