

CONSTRUCTION PLANS FOR MARSHALL COUNTY AIRPORT

LACON, MARSHALL COUNTY, ILLINOIS

CONSTRUCT A 2,065' X 35' PARTIAL PARALLEL TAXIWAY TO RUNWAY 13/31

SCOPE OF WORK

THIS PROJECT CONSISTS OF CONSTRUCTION OF A BITUMINOUS PARTIAL PARALLEL TAXIWAY, INCLUDING GRADING, DRAINAGE, PAVING, AIRFIELD ELECTRICAL, PAVEMENT MARKING, EROSION CONTROL ITEMS, INSTALLATION OF A NEW ELECTRICAL VAULT BUILDING, AND OTHER ASSOCIATED ITEMS.

COVERING
ELECTRICAL DESIGN

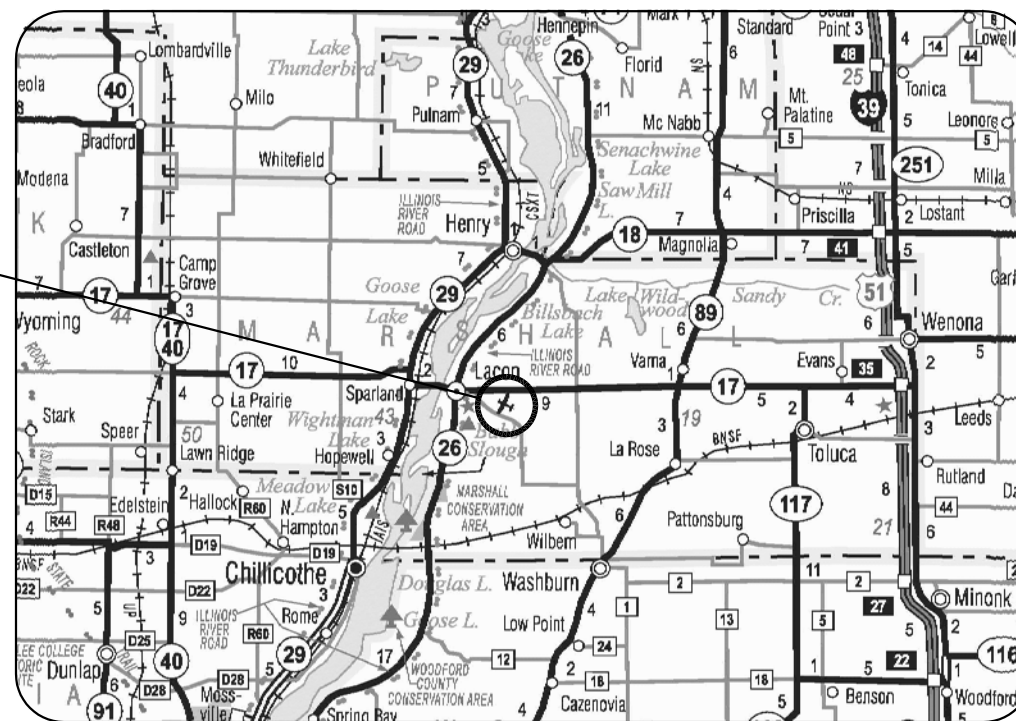

MARSHALL COUNTY AIRPORT



HANSON
Hanson Professional Services Inc.
ELECTRICAL ENGINEER

Submitted by: *Kevin N. Lightfoot* ENG'R

Date Submitted: 1/11/2013

Lics. Exp. Date: 11/30/2013

HANSON
Hanson Professional Services Inc.

Submitted by: *B. Stolz* ENG'R

Date Submitted: 1/11/2013

Lics. Exp. Date: 11/30/2013

MARSHALL COUNTY AIRPORT

Approved: *Boyd L. King* AIRPORT MANAGER

Date: 1/11/2013



LOCATION OF COUNTY

ILL. PROJ.: C75-4218
BLOCK GRANT PROJ.: 3-17-0059-B14

LATITUDE: 41° 01' 05"
LONGITUDE: 89° 23' 08"
ELEVATION: 569.0' M.S.L.
DATE: JANUARY 11, 2013

REVISION					
DATE					
MARSHALL COUNTY AIRPORT LACON, ILLINOIS					
BLOCK GRANT: 3-17-0059-B14 IL PROJ.: C75-4218					
Hanson Project No.	09A0031	LAYOUT	BAK	08/06/12	
Filename	C-001-CVR.dwg	DRAWN	BAK	08/06/12	
Scale	NOT TO SCALE	REVIEWED	BSS	01/11/13	
Date	01/11/13				
HANSON Hanson Professional Services Inc. 1525 North Lincoln Street Springfield, Illinois 62703-2886					
CONSTRUCT A 2,065' X 35' PARTIAL PARALLEL TAXIWAY TO RUNWAY 13/31					
COVER SHEET					
1 1 of 79 sheets					

SUMMARY OF QUANTITIES - BASE BID

ITEM NO.	DESCRIPTION	UNIT	TOTAL QUANTITIES	AS BUILT QUANTITIES
AR108158	1/C #8 5 KV UG CABLE IN UD	LF	11,800	
AR108258	2/C #8 5 KV UG CABLE IN UD	LF	3,980	
AR108656	3/C #6 600V UG CABLE IN UD	LF	6,180	
AR108756	1/C #6 GROUND	LF	8,320	
AR109110	ERECT PREFABRICATED VAULT	LS	1	
AR109200	INSTALL ELECTRICAL EQUIPMENT	LS	1	
AR109901	REMOVE ELECTRICAL VAULT	LS	1	
AR109924	REPLACE ELECTRIC SERVICES	LS	1	
AR110013	3" DIRECTIONAL BORE	LF	770	
AR110014	4" DIRECTIONAL BORE	LF	420	
AR110502	2-WAY CONCRETE ENCASED DUCT	LF	170	
AR110610	ELECTRICAL HANDHOLE	EA	12	
AR110710	ELECTRICAL MANHOLE	EA	4	
AR125410	MILT - STAKE MOUNTED	EA	94	
AR125415	MILT - BASE MOUNTED	EA	12	
AR125444	TAXI GUIDANCE SIGN, 4 CHARACTER	EA	1	
AR125446	TAXI GUIDANCE SIGN, 6 CHARACTER	EA	2	
AR125447	TAXI GUIDANCE SIGN, 7 CHARACTER	EA	2	
AR125565	SPLICE CAN	EA	2	
AR125901	REMOVE STAKE MOUNTED LIGHT	EA	36	
AR125902	REMOVE BASE MOUNTED LIGHT	EA	5	
AR125904	REMOVE TAXI GUIDANCE SIGN	EA	2	
AR150510	ENGINEER'S FIELD OFFICE	LS	1	
AR150520	MOBILIZATION	LS	1	
AR150540	HAUL ROUTE	LS	1	
AR152410	UNCLASSIFIED EXCAVATION	CY	10,384	
AR155540	BY-PRODUCT LIME	TON	313	
AR155616	SOIL PROCESSING - 16"	SY	8,680	
AR156510	SILT FENCE	LF	1,200	
AR156520	INLET PROTECTION	EA	6	
AR156530	TEMPORARY SEEDING	ACRE	5.5	
AR156531	EROSION CONTROL BLANKET	SY	3,670	
AR209510	CRUSHED AGGREGATE BASE COURSE	TON	4,000	
AR401613	BIT. SURF. CSE. -METHOD I, SUPERPAVE	TON	950	
AR403613	BIT. BASE CSE. -METHOD I, SUPERPAVE	TON	960	
AR602510	BITUMINOUS PRIME COAT	GAL	2,910	
AR603510	BITUMINOUS TACK COAT	GAL	825	
AR620520	PAVEMENT MARKING-WATERBORNE	SF	6,390	
AR620525	PAVEMENT MARKING-BLACK BORDER	SF	6,790	
AR620900	PAVEMENT MARKING REMOVAL	SF	650	
AR701512	12" RCP, CLASS IV	LF	87	
AR701518	18" RCP, CLASS IV	LF	133	
AR705506	6" PERFORATED UNDERDRAIN	LF	4,000	
AR705546	6" NON-PERFORATED UNDERDRAIN	LF	142	
AR705620	UNDERDRAIN END SECTION	EA	2	
AR705640	UNDERDRAIN CLEANOUT	EA	14	
AR752412	PRECAST REINFORCED CONC. FES 12"	EA	2	
AR752418	PRECAST REINFORCED CONC. FES 18"	EA	2	
AR800424	INSTALL INFORMATION SIGN	EA	1	
AR800425	REMOVE INFORMATION SIGN	EA	1	
AR800591	UPGRADE AIRPORT ROTATING BEACON	LS	1	
AR901510	SEEDING	ACRE	5.5	
AR908510	MULCHING	ACRE	5.5	

EARTHWORK QUANTITY SUMMARY:

CUT (INCLUDING BORROW AREA #1).....10,384 CY
 FILL 9,029 CY
 FILL + 15%10,384 CY

GENERAL NOTES:

QUANTITIES

PAYMENT WILL BE MADE UNDER THE ITEM NUMBERS, DESCRIPTIONS AND UNITS NOTED IN THE ABOVE TABLE IN ACCORDANCE WITH THE BASIS OF PAYMENT FOR EACH RESPECTIVE WORK ITEM COMPLETED AND ACCEPTED BY THE ENGINEER.

CERTIFIED PAYROLLS

THE RESIDENT ENGINEER CANNOT FORWARD CONSTRUCTION REPORTS TO THE ILLINOIS DIVISION OF AERONAUTICS FOR PROCESSING UNTIL ALL CERTIFIED PAYROLLS FOR THE PERIOD HAVE BEEN RECEIVED.

MATERIAL CERTIFICATIONS

COMPLETED WORK CANNOT BE PLACED ON A CONSTRUCTION REPORT UNTIL ALL MATERIAL CERTIFICATIONS FOR THAT PAY ITEM HAVE BEEN RECEIVED, REVIEWED AND ACCEPTED BY THE RESIDENT ENGINEER.

INDEX TO SHEETS

SHEET NO.	DESCRIPTION
1	COVER SHEET
2	SUMMARY OF QUANTITIES AND INDEX TO SHEETS
3	PROPOSED SCOPE OF WORK PLAN
4	SURVEY BASE SHEET
5	PROPOSED SAFETY AND PHASING PLAN-WORK AREA 1
6	PROPOSED SAFETY AND PHASING PLAN-WORK AREA 2
7	PROPOSED SAFETY AND PHASING PLAN-WORK AREA 3
8	PROPOSED SAFETY AND PHASING PLAN-WORK AREA 4
9	CONSTRUCTION SAFETY AND PHASING DETAILS AND NOTES
10	PROPOSED TYPICAL SECTIONS
11	CONSTRUCTION PLAN - STA. 117+00 TO STA. 137+00
12	CONSTRUCTION PLAN - STA. 137+00 TO STA. 148+00
13	MISCELLANEOUS CONSTRUCTION DETAILS
14	PLAN AND PROFILE - STA. 117+00 TO STA. 127+00
15	PLAN AND PROFILE - STA. 127+00 TO STA. 137+00
16	PLAN AND PROFILE - STA. 137+00 TO STA. 148+00
17	SPOT ELEVATION PLAN
18	PROPOSED MARKING PLAN STA. 117+00 TO STA. 127+00
19	PROPOSED MARKING PLAN STA. 127+00 TO STA. 153+00
20	PROPOSED STORMWATER POLLUTION PREVENTION PLAN
21	PROPOSED STORMWATER POLLUTION PREVENTION PLAN (2)
22	PROPOSED STORMWATER POLLUTION PREVENTION DETAILS
23	CROSS SECTIONS STA. 120+50 TO STA. 121+00.25
24	CROSS SECTIONS STA. 121+00.25 TO STA. 121+50.25
25	CROSS SECTIONS STA. 121+50.25 TO STA. 123+00
26	CROSS SECTIONS STA. 123+50 TO STA. 124+50
27	CROSS SECTIONS STA. 125+00 TO STA. 125+50
28	CROSS SECTIONS STA. 126+00
29	CROSS SECTIONS STA. 126+50
30	CROSS SECTIONS STA. 127+00
31	CROSS SECTIONS STA. 127+50
32	CROSS SECTIONS STA. 128+00
33	CROSS SECTIONS STA. 128+50 TO STA. 129+00
34	CROSS SECTIONS STA. 129+50 TO STA. 130+00
35	CROSS SECTIONS STA. 130+50 TO STA. 131+00
36	CROSS SECTIONS STA. 131+50 TO STA. 133+00
37	CROSS SECTIONS STA. 133+50 TO STA. 135+00
38	CROSS SECTIONS STA. 135+50 TO STA. 137+00
39	CROSS SECTIONS STA. 137+50 TO STA. 139+00
40	CROSS SECTIONS STA. 139+25 TO STA. 140+50
41	CROSS SECTIONS STA. 141+00 TO STA. 141+42.50
42	EXISTING ELECTRICAL PLAN STA. 117+00 TO STA. 127+00
43	EXISTING ELECTRICAL PLAN STA. 127+00 TO STA. 137+00
44	EXISTING ELECTRICAL PLAN STA. 137+00 TO STA. 148+00
45	EXISTING ELECTRICAL PLAN STA. 148+00 TO STA. 153+00
46	EXISTING ELECTRICAL PLAN 400' RT.
47	PROPOSED ELECTRICAL PLAN STA. 117+00 TO STA. 127+00
48	PROPOSED ELECTRICAL PLAN STA. 127+00 TO STA. 137+00
49	PROPOSED ELECTRICAL PLAN STA. 137+00 TO STA. 148+00
50	PROPOSED ELECTRICAL PLAN STA. 148+00 TO STA. 153+00
51	PROPOSED ELECTRICAL PLAN 400' RT.
52	AIRFIELD LIGHTING SCHEDULES AND LIGHT LOCATION TABLE
53	ELECTRICAL DETAILS SHEET 1
54	ELECTRICAL DETAILS SHEET 2
55	ELECTRICAL DETAILS SHEET 3
56	ELECTRICAL DETAILS SHEET 4
57	4' X 4' X 4' ELECTRICAL MANHOLE
58	AIRPORT ROTATING BEACON UPGRADE DETAILS AND NOTES
59	ELECTRICAL NOTES SHEET 1
60	ELECTRICAL NOTES SHEET 2
61	ELECTRICAL LEGEND AND ABBREVIATIONS
62	EXISTING ELECTRICAL ONE-LINE DIAGRAM FOR VAULT AND AIRFIELD
63	PROPOSED ELECTRICAL ONE-LINE DIAGRAM FOR T-HANGAR SERVICE PANEL
64	PROPOSED VAULT ELECTRICAL EQUIPMENT PLAN
65	PROPOSED VAULT LIGHTING AND RECEPTACLE PLAN
66	PROPOSED AIRPORT VAULT WALL ELEVATIONS (SHEET 1)
67	PROPOSED AIRPORT VAULT WALL ELEVATIONS (SHEET 2)
68	PROPOSED ELECTRICAL ONE-LINE DIAGRAM FOR VAULT AND AIRFIELD
69	PROPOSED ELECTRICAL ONE-LINE DIAGRAM FOR VAULT AND AIRFIELD (CONT.)
70	PANELBOARD SCHEDULES
71	AIRFIELD LIGHTING CONTROL WIRING SCHEMATIC
72	CONTROL PANEL FOR AIRFIELD NAVAIDS SCHEMATIC
73	CONTROL PANEL FOR AIRFIELD NAVAIDS AND VAULT FAN
74	HIGH VOLTAGE WIRING SCHEMATIC FOR RWY 13-31 & TAXIWAY
75	HIGH VOLTAGE WIRING SCHEMATIC FOR RUNWAY 18-36
76	LEGEND PLATE SCHEDULES
77	VAULT GROUND BUS RISER
78	GROUNDING DETAILS
79	GROUNDING NOTES

REVISION		DATE	
MARSHALL COUNTY AIRPORT LACON, ILLINOIS			
Hanson, Project No. 09A0031 C-002-FLP.dwg Scale NOT TO SCALE Date 01/11/13		LAYOUT BAK 08/06/12 DRAWN BAK 08/06/12 REVIEWED BSS 01/11/13	IL PROJ.: C75-4218 BLOCK GRANT: 3-17-0059-B14
 © Copyright Hanson Professional Services Inc. 2013 Hanson Professional Services Inc. 1525 S. 36th St. Springfield, Illinois 62703-2886			
CONSTRUCT A 2,065' X 35' PARTIAL PARALLEL TAXIWAY TO RUNWAY 13/31		SUMMARY OF QUANTITIES AND INDEX TO SHEETS	
2 2 of 79 sheets			

GENERAL NOTES

1. THE SCOPE OF WORK SHEET IS INTENDED ONLY AS A GENERAL DESCRIPTION OF WORK ITEMS AND THEIR APPROXIMATE LOCATIONS AND LIMITS, FOR THE PURPOSE OF UNDERSTANDING THE SCOPE OF THE PROJECT. THIS SHEET SHALL NOT BE USED AS A CONSTRUCTION PLAN. REFER TO THE FOLLOWING PLAN SHEETS FOR DETAILED CONSTRUCTION REQUIREMENTS, LOCATIONS, AND ITEMS OF WORK.
2. WORK FOR THIS PROJECT SHALL CONSIST OF, BUT IS NOT LIMITED TO, CONSTRUCTION OF A BITUMINOUS PARTIAL PARALLEL TAXIWAY, INCLUDING GRADING, DRAINAGE, PAVING, AIRFIELD ELECTRICAL, PAVEMENT MARKING, EROSION CONTROL ITEMS, INSTALLATION OF A NEW ELECTRICAL VAULT BUILDING, AND OTHER ASSOCIATED ITEMS.
3. THE CONTRACTOR SHALL FURNISH ALL LABOR, MATERIAL, EQUIPMENT, AND TRANSPORTATION NECESSARY TO CONSTRUCT ALL ELEMENTS OF THE PROJECT AS DESCRIBED IN THE CONSTRUCTION PLANS AND SPECIFICATIONS.
4. THE RULES, REGULATIONS, AND SPECIFICATIONS ENUMERATED HEREIN SHALL BE CONSIDERED AS MINIMUM REQUIREMENTS. THEY SHALL NOT PROHIBIT THE CONTRACTOR FROM FURNISHING AND INSTALLING HIGHER GRADES OF MATERIAL THAN ARE SPECIFIED HEREIN.
5. THE CONTRACTOR IS NOT PERMITTED TO USE THE AIRPORT ENTRANCE DRIVE AND AUTO PARKING LOT FOR MATERIAL AND EQUIPMENT HAULING OR STORAGE. THE CONSTRUCTION ENTRANCE AS SHOWN ON THE SCOPE OF WORK AND/OR SAFETY PHASING PLAN ARE ONLY TO BE USED FOR THE PROJECT. ACCESS TO THE PROJECT FOR ALL HAULING OF MATERIALS AND EQUIPMENT SHALL BE RESTRICTED TO THE DESIGNATED CONSTRUCTION ENTRANCE.
6. IT SHALL BE THE RESPONSIBILITY OF THE CONTRACTOR TO PROTECT, PRESERVE AND REPAIR THE EXISTING AIRFIELD AND ROADWAY PAVEMENTS AT ALL TIMES. THE CONTRACTOR SHALL REPAIR ANY DAMAGE TO EXISTING ELECTRICAL, DRAINAGE, AND PAVEMENT STRUCTURES AT NO ADDITIONAL COST TO THE CONTRACT.
7. NO EQUIPMENT SHALL BE PERMITTED TO CROSS OR USE ANY EXISTING PAVEMENT OUTSIDE THE CONSTRUCTION LIMITS, GENERAL PROJECT AREA OR HAUL ROUTE.
8. CONTRACTOR IS REQUIRED TO PROVIDE THEIR OWN RESTROOM FACILITIES.
9. UNLESS OTHERWISE NOTED, ALL DISTURBED AREAS OUTSIDE OF THE PROPOSED CONSTRUCTION LIMITS SHALL BE GRADED, SEEDED AND/OR HYDROMULCH SEEDED AT NO ADDITIONAL COST TO THE CONTRACT.
10. ALL WASTE MATERIAL SHALL BE HAULED FROM THE AIRPORT AND PROPERLY DISPOSED OF UNLESS OTHERWISE SPECIFIED HEREIN.
11. THE CONTRACTOR SHALL BE RESPONSIBLE FOR OBTAINING PERMITS FOR HAULING ON PUBLIC ROADS, AS APPLICABLE. THE CONTRACTOR SHALL BE RESPONSIBLE FOR CORRECTING ANY DAMAGES TO ANY PAVEMENTS (PUBLIC OR PRIVATE) CAUSED BY HIS/HER CONSTRUCTION EQUIPMENT OR PERSONNEL.
12. THE OWNER SHALL HAVE THE RIGHT OF FIRST REFUSAL FOR ALL SALVAGEABLE MATERIAL REMOVED ON THE PROJECT.
13. THE CONTRACTOR SHALL PROVIDE ONE SET OF REDLINED AS-BUILT DRAWINGS TO THE RESIDENT ENGINEER AT THE COMPLETION OF THE PROJECT.
14. CONTRACTOR SHALL NOTE THAT ALL AREAS WITHIN THE AIRPORT PROPERTY LINE AND OUTSIDE THE CONSTRUCTION LIMITS MAY BE USED FOR AGRICULTURAL PURPOSES. THE CONSTRUCTION LIMITS SHALL BE RESTRICTED TO AREAS THAT ARE ABSOLUTELY NECESSARY TO DISTURB TO COMPLETE THE REQUIRED WORK ITEMS. LIMITS SHALL BE COORDINATED WITH THE RESIDENT ENGINEER PRIOR TO BEGINNING ANY WORK. ALL AREAS WHICH HAVE BEEN FARMED AND OR DESIGNATED TO BE FARMED AFTER THE PROJECT COMPLETION, AND HAVE BEEN DISTURBED BY CONSTRUCTION ACTIVITY, SHALL BE CHISEL PLOWED (36" MAX.) OR OTHERWISE SCARIFIED TO RETURN THE AREA TO A REASONABLE TILLABLE CONDITION (IF SO PERMITTED BY THE AIRPORT MANAGER.)
15. CONTRACTOR SHALL RESTORE TO ORIGINAL CONDITION ALL GRASS, STONE, OR PAVEMENT DISTURBED BY CONTRACTOR'S CONSTRUCTION OPERATIONS, STAGING, AND CONSTRUCTION ACCESS ROUTES. DISTURBED AREAS TO BE REPAIRED, GRADED, AND MULCHED SEEDED UNLESS OTHERWISE NOTED. STAGING AREA AND SITE ACCESS RESTORATION SHALL BE INCLUDED IN THE COST OF THE HAUL ROUTE.
16. THE PROJECT PAY ITEMS ARE INTENDED TO BE INCLUSIVE OF ALL WORK TO BE PERFORMED AS SHOWN IN THESE PLANS. ALL INCIDENTAL WORK REQUIRED TO COMPLETE THE PROJECT TO THE SATISFACTION OF THE RESIDENT ENGINEER IS TO BE INCLUDED IN THE COSTS OF PERFORMING THESE ITEMS.
17. APPROXIMATE LOCATIONS OF UNDERGROUND UTILITIES ARE SHOWN THROUGHOUT THESE PLANS. THE CONTRACTOR SHALL DETERMINE EXACT LOCATIONS AND PROTECT THESE UTILITIES DURING CONSTRUCTION. ANY UTILITIES DAMAGED DURING CONSTRUCTION SHALL BE REPAIRED AT THE CONTRACTOR'S EXPENSE. CONTRACTOR SHALL COORDINATE WITH THE PROPER PERSONS FOR THE PURPOSE OF LOCATING AND PROTECTING EXISTING UNDERGROUND UTILITIES.
18. THE CONTRACTOR MUST AT ALL TIMES MAINTAIN PROPER DRAINAGE FOR ALL AREAS AFFECTED BY HIS WORK.
19. THE CONTRACTOR SHALL NOTE THAT OTHER CONTRACTORS WILL BE WORKING IN THE VICINITY AND WILL REQUIRE ACCESS TO THEIR WORK AREAS. COORDINATION BETWEEN CONTRACTORS IS ANTICIPATED AND EXPECTED.

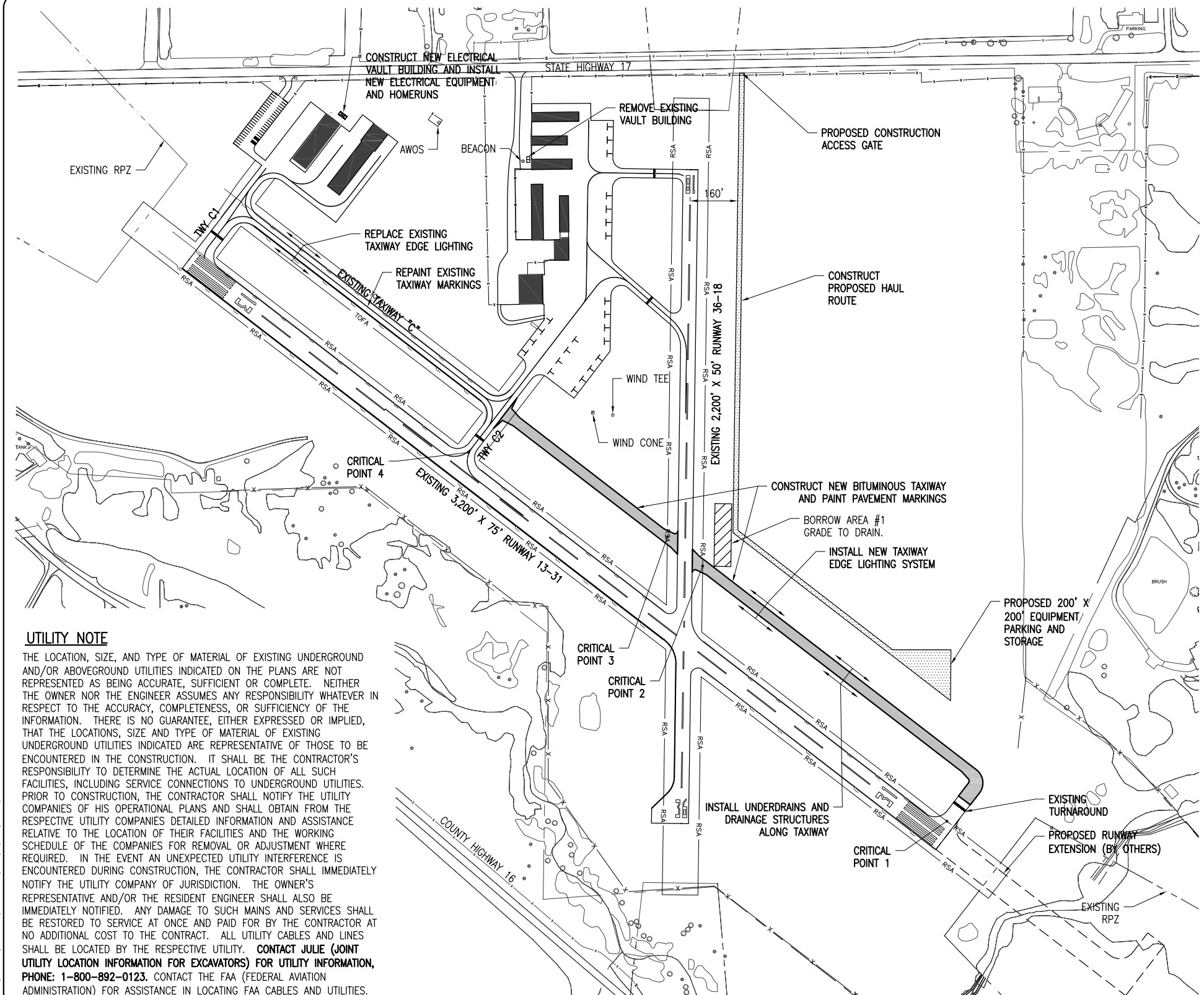

UTILITY NOTE
 THE LOCATION, SIZE, AND TYPE OF MATERIAL OF EXISTING UNDERGROUND AND/OR ABOVEGROUND UTILITIES INDICATED ON THE PLANS ARE NOT REPRESENTED AS BEING ACCURATE, SUFFICIENT OR COMPLETE. NEITHER THE OWNER NOR THE ENGINEER ASSUMES ANY RESPONSIBILITY WHATSOEVER IN RESPECT TO THE ACCURACY, COMPLETENESS, OR SUFFICIENCY OF THE INFORMATION. THERE IS NO GUARANTEE, EITHER EXPRESSED OR IMPLIED, THAT THE LOCATIONS, SIZE AND TYPE OF MATERIAL OF EXISTING UNDERGROUND UTILITIES INDICATED ARE REPRESENTATIVE OF THOSE TO BE ENCOUNTERED IN THE CONSTRUCTION. IT SHALL BE THE CONTRACTOR'S RESPONSIBILITY TO DETERMINE THE ACTUAL LOCATION OF ALL SUCH FACILITIES, INCLUDING SERVICE CONNECTIONS TO UNDERGROUND UTILITIES. PRIOR TO CONSTRUCTION, THE CONTRACTOR SHALL NOTIFY THE UTILITY COMPANIES OF HIS OPERATIONAL PLANS AND SHALL OBTAIN FROM THE RESPECTIVE UTILITY COMPANIES DETAILED INFORMATION AND ASSISTANCE RELATIVE TO THE LOCATION OF THEIR FACILITIES AND THE WORKING SCHEDULE OF THE COMPANIES FOR REMOVAL OR ADJUSTMENT WHERE REQUIRED. IN THE EVENT AN UNEXPECTED UTILITY INTERFERENCE IS ENCOUNTERED DURING CONSTRUCTION, THE CONTRACTOR SHALL IMMEDIATELY NOTIFY THE UTILITY COMPANY OF JURISDICTION. THE OWNER'S REPRESENTATIVE AND/OR THE RESIDENT ENGINEER SHALL ALSO BE IMMEDIATELY NOTIFIED. ANY DAMAGE TO SUCH MAINS AND SERVICES SHALL BE RESTORED TO SERVICE AT ONCE AND PAID FOR BY THE CONTRACTOR AT NO ADDITIONAL COST TO THE CONTRACT. ALL UTILITY CABLES AND LINES SHALL BE LOCATED BY THE RESPECTIVE UTILITY. **CONTACT JULIE (JOINT UTILITY LOCATION INFORMATION FOR EXCAVATORS) FOR UTILITY INFORMATION, PHONE: 1-800-892-0123.** CONTACT THE FAA (FEDERAL AVIATION ADMINISTRATION) FOR ASSISTANCE IN LOCATING FAA CABLES AND UTILITIES. LOCATION OF FAA POWER, CONTROL, AND COMMUNICATION CABLES SHALL BE COORDINATED WITH AND/OR LOCATED BY THE FAA. ALSO CONTACT AIRPORT DIRECTOR/MANAGER AND AIRPORT PERSONNEL FOR ASSISTANCE IN LOCATING UNDERGROUND AIRPORT CABLES AND/OR UTILITIES. ALSO COORDINATE WORK WITH ALL ABOVEGROUND UTILITIES.

J.U.L.I.E. INFORMATION
 COUNTY _____ MARSHALL
 CITY _____ LACON
 TOWNSHIP _____ HOPEWELL
 SECTION NO. _____ 31
 ADDRESS _____ MARSHALL COUNTY AIRPORT
 LACON, ILLINOIS 61540

CRITICAL POINT DATA			
POINT #	LATITUDE	LONGITUDE	ELEVATION
1	N 041° 00' 59.60"	W 089° 22' 56.69"	567.26
2	N 041° 01' 08.14"	W 089° 23' 07.30"	552.02
3	N 041° 01' 09.12"	W 089° 23' 08.83"	552.55
4	N 041° 01' 11.99"	W 089° 23' 17.52"	548.44

LEGEND

- EXISTING IMPROVEMENTS
- PROPOSED IMPROVEMENTS
- FUTURE IMPROVEMENTS
- EXISTING BUILDINGS
- PROPOSED HAUL ROUTE AND EQUIPMENT PARKING AREA

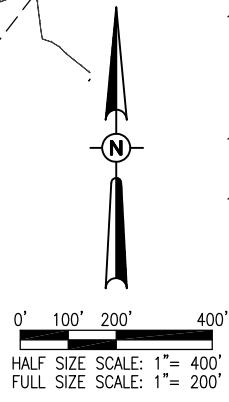

REVISION					
DATE					
MARSHALL COUNTY AIRPORT LACON, ILLINOIS					
BLOCK GRANT: 3-17-0059-B14					
IL PROJ.: C75-4218					
Hanson Project No. 09A0031	Filename C-003-SOW.dwg	Scale 1" = 200'	Date 01/11/13	LAYOUT BAK 08/07/12	DRAWN BAK 08/07/12
				REVIEWED BSS 01/11/13	
© Copyright Hanson Professional Services Inc. 2013 Hanson Professional Services Inc. 1625 So. W. 11th St., Suite 200 Springfield, Illinois 62703-2886					
CONSTRUCT A 2,065' X 35' PARTIAL PARALLEL TAXIWAY TO RUNWAY 13/31			PROPOSED SCOPE OF WORK		
3					
3 of 79 sheets					

JAN 11, 2013 1:14 PM HARR01115
 p:\s\svr306\hanson\dom\hanson\Projects\Documents\09A0031\09A0031D\CAD\Airport\Sheet\C-003-SOW

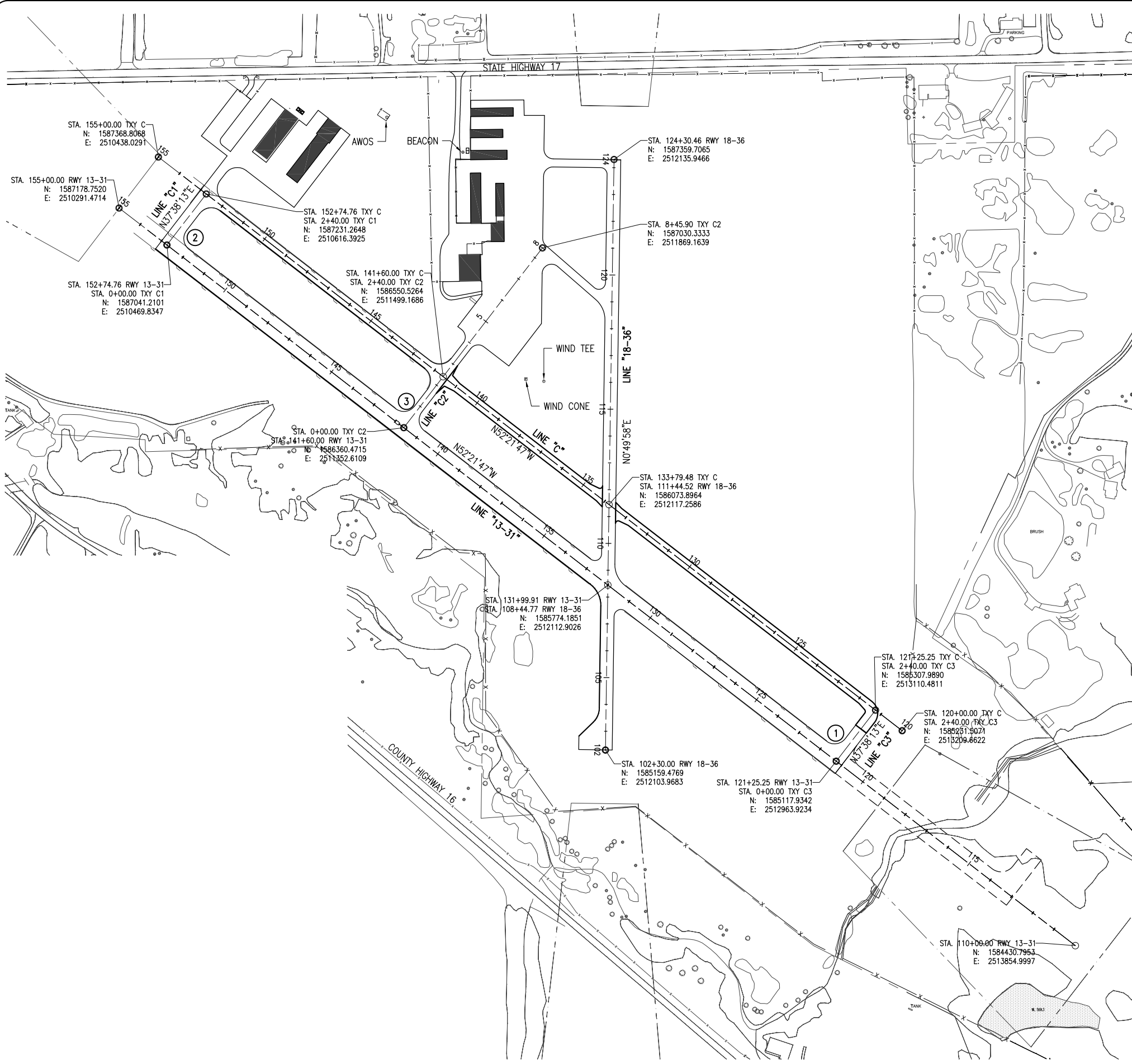

LEGEND

- EXISTING IMPROVEMENTS
- PROPOSED IMPROVEMENTS
- FUTURE IMPROVEMENTS
- EXISTING BUILDINGS
- ① SURVEY CONTROL POINTS

0' 100' 200' 400'
 HALF SIZE SCALE: 1" = 400'
 FULL SIZE SCALE: 1" = 200'

CONTROL POINT DATA

NO.	DESCRIPTION	NORTHING	EASTING	ELEV.
1	LACPORT NGS MONUMENT	1,585,214.690	2,512,981.969	565.44
2	LACPORT AZ MONUMENT	1,587,067.557	2,510,579.083	536.82
3	5/8" IRON PIN W/ HEI METAL CAP	1,586,449.457	2,511,380.665	549.16

SURVEY NOTES

1. ALL COORDINATE VALUES SHOWN IN TABLE ARE BASED ON ILLINOIS STATE PLANE - WEST ZONE NAD-83.
2. REFER TO IDOT STANDARD SPECIFICATIONS 50-06, CONSTRUCTION LAYOUT STAKES, FOR ADDITIONAL INFORMATION.

REVISION	DATE

**MARSHALL COUNTY AIRPORT
LACON, ILLINOIS**

BLOCK GRANT: 3-17-0059-B14
 IL PROJ.: C75-4218

Hanson Project No.	09A0031
Filename	C-008-SURV.dwg
Scale	1" = 200'
Date	01/11/13
LAYOUT	BAK 08/07/12
DRAWN	BAK 08/07/12
REVIEWED	BSS 01/11/13

HANSON

© Copyright Hanson Professional Services Inc. 2013
 Hanson Professional Services Inc.
 1525 South State Street
 Springfield, Illinois 62703-2886

CONSTRUCT A 2,065' X 35'
PARTIAL PARALLEL TAXIWAY
TO RUNWAY 13/31

SURVEY BASE SHEET

JAN 11, 2013 1:14 PM HARR01115
 pw:\s\spi-svr306.hanson.com\Hanson Projects\Documents\09_lob\09A0031\09A0031D\CAD\Airport\Sheet\C-008-SURV

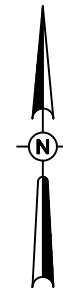

0' 100' 200' 400'
 HALF SIZE SCALE: 1" = 400'
 FULL SIZE SCALE: 1" = 200'

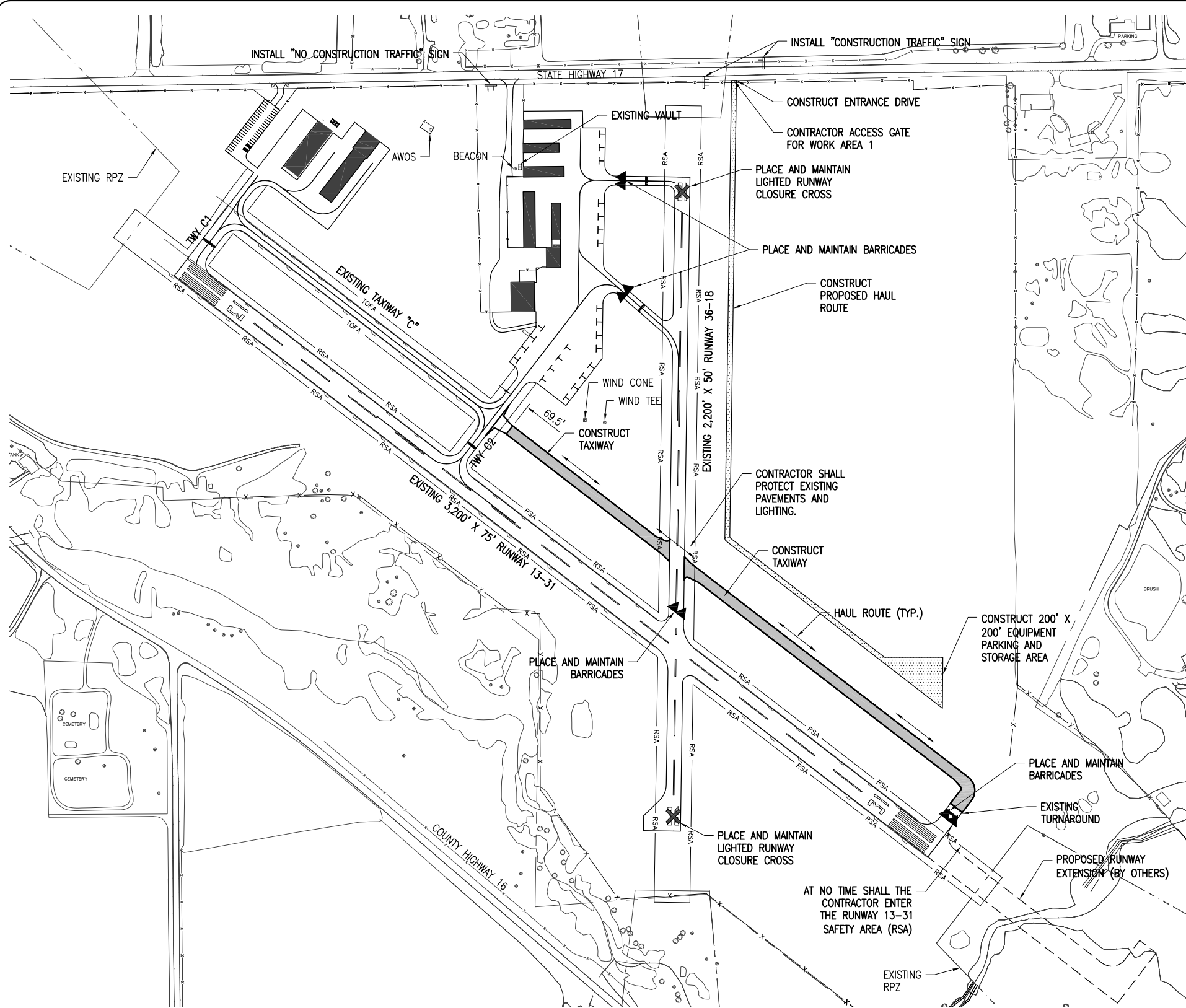

WORK AREA 1 NOTES

1. THE WORK ITEMS TO BE COMPLETED IN AREA 1 INCLUDE CONSTRUCTION OF THE HAUL ROUTE AND STAGING AREA, CONSTRUCTION OF THE BITUMINOUS TAXIWAY "C" EXTENSION WITHIN THE LIMITS SHOWN, INCLUDING GRADING, DRAINAGE, PAVING, MARKING, LIGHTING AND EROSION CONTROL.
2. THE CONTRACTOR SHALL HAVE A MAXIMUM OF 45 CONSECUTIVE CALENDAR DAYS TO COMPLETE THE WORK IN THIS AREA.
3. CLOSURE CROSSES AND BARRICADES SHALL BE IN PLACE PRIOR TO BEGINNING CONSTRUCTION.
4. AT ALL TIMES, THE CONTRACTOR'S OPERATIONS SHALL BE SUCH AS TO MINIMIZE CLOSURES.
5. THE CONTRACTOR SHALL COORDINATE ACCESS TO THE RUNWAY FOR SURVEYING (LAYOUT OF CONTROL, ETC.) WITH THE AIRPORT A MINIMUM OF 24 HOURS BEFORE ACCESSING THE RUNWAY. ACCESS TO THE RUNWAY DURING DAYLIGHT HOURS WILL BE LIMITED TO VFR CONDITIONS ONLY AND AT THE DISCRETION OF THE AIRPORT. THE CONTRACTOR WILL BE REQUIRED TO "PULL BACK" ALL EQUIPMENT AND PERSONNEL FROM THE RUNWAY WHEN DIRECTED BY THE AIRPORT.

LEGEND

- EXISTING IMPROVEMENTS
- PROPOSED IMPROVEMENTS
- FUTURE IMPROVEMENTS
- EXISTING BUILDINGS
- PROPOSED HAUL ROUTE AND EQUIPMENT PARKING AREA
- RUNWAY SAFETY AREA (120' WIDE)
- TAXIWAY OBJECT FREE AREA (89' WIDE)
- RUNWAY PROTECTION ZONE
- PROPOSED RUNWAY/TAXIWAY CLOSURE CROSS
- PROPOSED BARRICADES
- CONSTRUCTION SIGN

REVISION	DATE

MARSHALL COUNTY AIRPORT
 LACON, ILLINOIS

IL PROJ.: C75-4218 BLOCK GRANT: 3-17-0059-B14

Hanson Project No.	09A0031	LAYOUT	BAK	08/07/12
Filename	C-004-SFY.dwg	DRAWN	BAK	08/07/12
Scale	1" = 200'	REVIEWED	BSS	01/11/13
Date	01/11/13			



© Copyright Hanson Professional Services Inc. 2013
 Hanson Professional Services Inc.
 1425 South Main Street
 Springfield, Illinois 62703-2886

CONSTRUCT A 2,065' X 35'
 PARTIAL PARALLEL TAXIWAY
 TO RUNWAY 13/31

PROPOSED SAFETY AND
 PHASING PLAN-WORK AREA 1

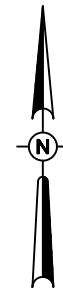

0' 100' 200' 400'
 HALF SIZE SCALE: 1" = 400'
 FULL SIZE SCALE: 1" = 200'

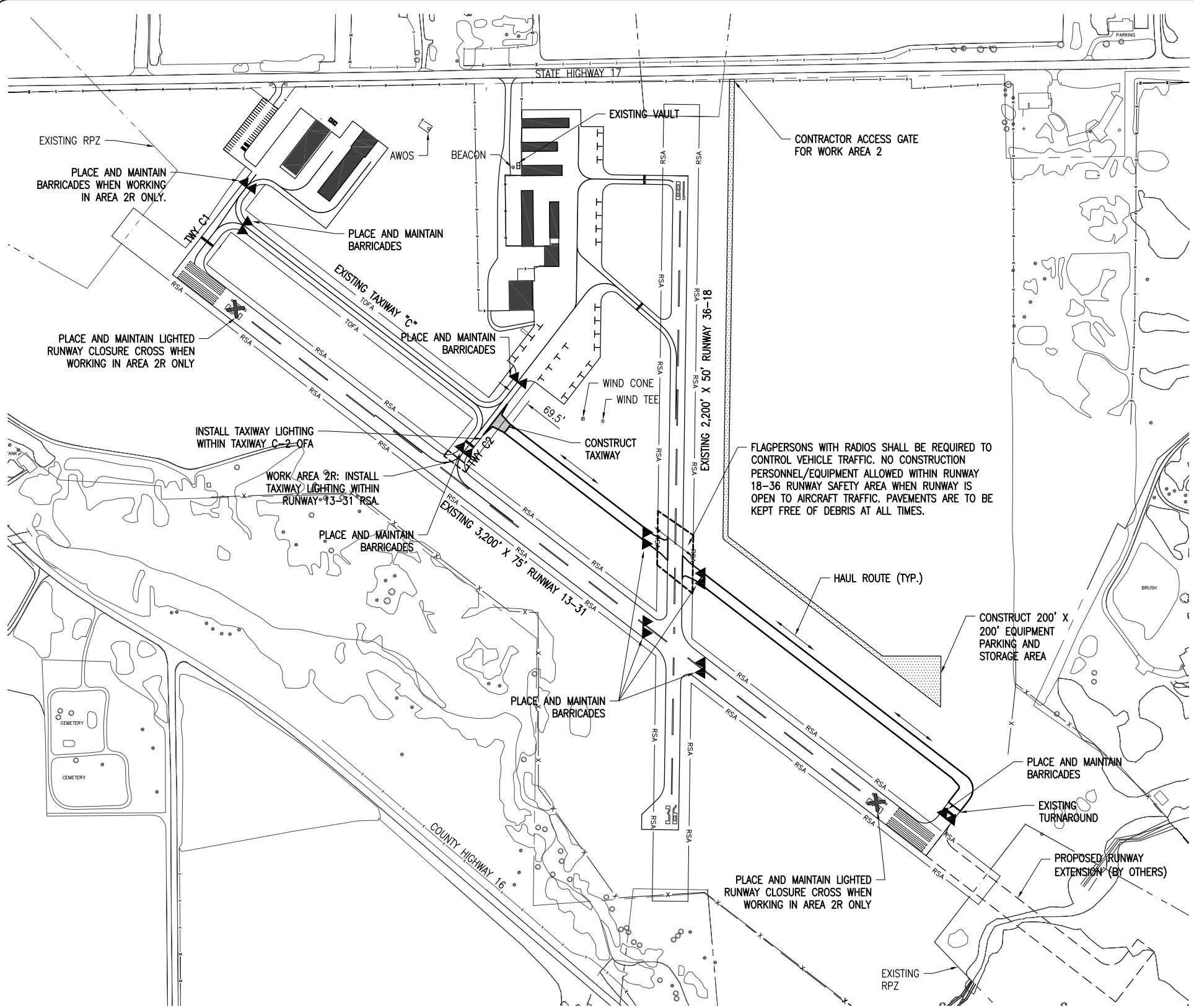

WORK AREA 2 NOTES

1. THE WORK ITEMS TO BE COMPLETED IN AREA 2 INCLUDE CONSTRUCTION OF THE BITUMINOUS TAXIWAY "C" EXTENSION WITHIN THE LIMITS SHOWN, INCLUDING GRADING, DRAINAGE, PAVING, MARKING, LIGHTING AND EROSION CONTROL. ALSO INCLUDED IS THE REPLACEMENT OF TAXIWAY EDGE LIGHTING WITHIN THE TAXIWAY "C-2" OBJECT FREE AREA LIMITS.
2. THE CONTRACTOR SHALL HAVE A MAXIMUM OF 14 CONSECUTIVE CALENDAR DAYS TO COMPLETE THE WORK IN THIS AREA, INCLUSIVE OF WORK AREA 2R.
3. CLOSURE CROSSES AND BARRICADES SHALL BE IN PLACE PRIOR TO BEGINNING CONSTRUCTION.
4. AT ALL TIMES, THE CONTRACTOR'S OPERATIONS SHALL BE SUCH AS TO MINIMIZE CLOSURES.
5. THE CONTRACTOR MAY WORK IN AREAS 2 AND 2R SIMULTANEOUSLY. HOWEVER, CONTRACT TIME PROVISIONS SHALL STILL BE ENFORCED FOR EACH AREA.
6. THE CONTRACTOR MAY WORK IN AREAS 2 AND 3 SIMULTANEOUSLY. HOWEVER, CONTRACT TIME PROVISIONS SHALL STILL BE ENFORCED FOR EACH AREA.

WORK AREA 2R NOTES

1. THE WORK ITEMS TO BE COMPLETED IN AREA 2R INCLUDE REPLACEMENT OF TAXIWAY EDGE LIGHTING WITHIN THE RUNWAY 13-31 SAFETY AREA LIMITS.
2. THE CONTRACTOR SHALL HAVE A MAXIMUM OF 1 CALENDAR DAY TO COMPLETE THE WORK IN THIS AREA. THIS WORK SHALL BE ACCOMPLISHED BETWEEN MONDAY AND FRIDAY OF A GIVEN WEEK, TO BE COORDINATED WITH THE OWNER AND ENGINEER.
3. CLOSURE CROSSES AND BARRICADES SHALL BE IN PLACE PRIOR TO BEGINNING CONSTRUCTION.
4. RUNWAY 13-31 SHALL BE NOTAMED "CLOSED". THE PAVIS AND REILS SHALL BE NOTAMED "SHUTDOWN". WHENEVER THE RUNWAY IS CLOSED, ALL ASSOCIATED LIGHTING SHALL BE TURNED OFF OR COMPLETELY COVERED, INCLUDING THE RUNWAY EDGE LIGHTS, PAVIS AND REILS. CONTRACTOR SHALL COORDINATE WITH THE AIRPORT AT LEAST 48 HOURS BEFORE WORKING WITHIN THE RUNWAY SAFETY AREAS SO THAT NOTAMS MAY BE COORDINATED.
5. AT ALL TIMES, THE CONTRACTOR'S OPERATIONS SHALL BE SUCH AS TO MINIMIZE CLOSURES.
6. THE CONTRACTOR MAY WORK IN AREAS 2 AND 2R SIMULTANEOUSLY. HOWEVER, CONTRACT TIME PROVISIONS SHALL STILL BE ENFORCED FOR EACH AREA.
7. THE CONTRACTOR MAY WORK IN AREAS 2R AND 4R SIMULTANEOUSLY. HOWEVER, CONTRACT TIME PROVISIONS SHALL STILL BE ENFORCED FOR EACH AREA.

LEGEND

- EXISTING IMPROVEMENTS
- PROPOSED IMPROVEMENTS
- FUTURE IMPROVEMENTS
- EXISTING BUILDINGS
- PROPOSED HAUL ROUTE AND EQUIPMENT PARKING AREA
- RUNWAY SAFETY AREA (120' WIDE)
- TAXIWAY OBJECT FREE AREA (89' WIDE)
- RUNWAY PROTECTION ZONE
- PROPOSED RUNWAY/TAXIWAY CLOSURE CROSS
- PROPOSED BARRICADES

REVISION	DATE

MARSHALL COUNTY AIRPORT
 LACON, ILLINOIS

IL PROJ.: C75-4218 BLOCK GRANT: 3-17-0059-B14

Hanson Project No.	09A0031
Filename	C-005-SFY.dwg
Scale	1" = 200'
Date	01/11/13
LAYOUT	BAK 08/07/12
DRAWN	BAK 08/07/12
REVIEWED	BSS 01/11/13



© Copyright Hanson Professional Services Inc. 2013
 Hanson Professional Services Inc.
 1525 S. 36th Street
 Springfield, Illinois 62703-2886

CONSTRUCT A 2,065' X 35'
 PARTIAL PARALLEL TAXIWAY
 TO RUNWAY 13/31

PROPOSED SAFETY AND
 PHASING PLAN-WORK AREA 2

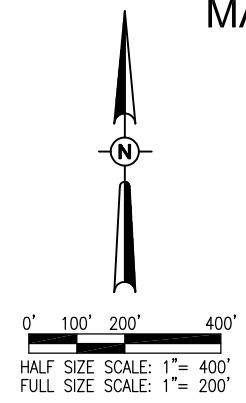
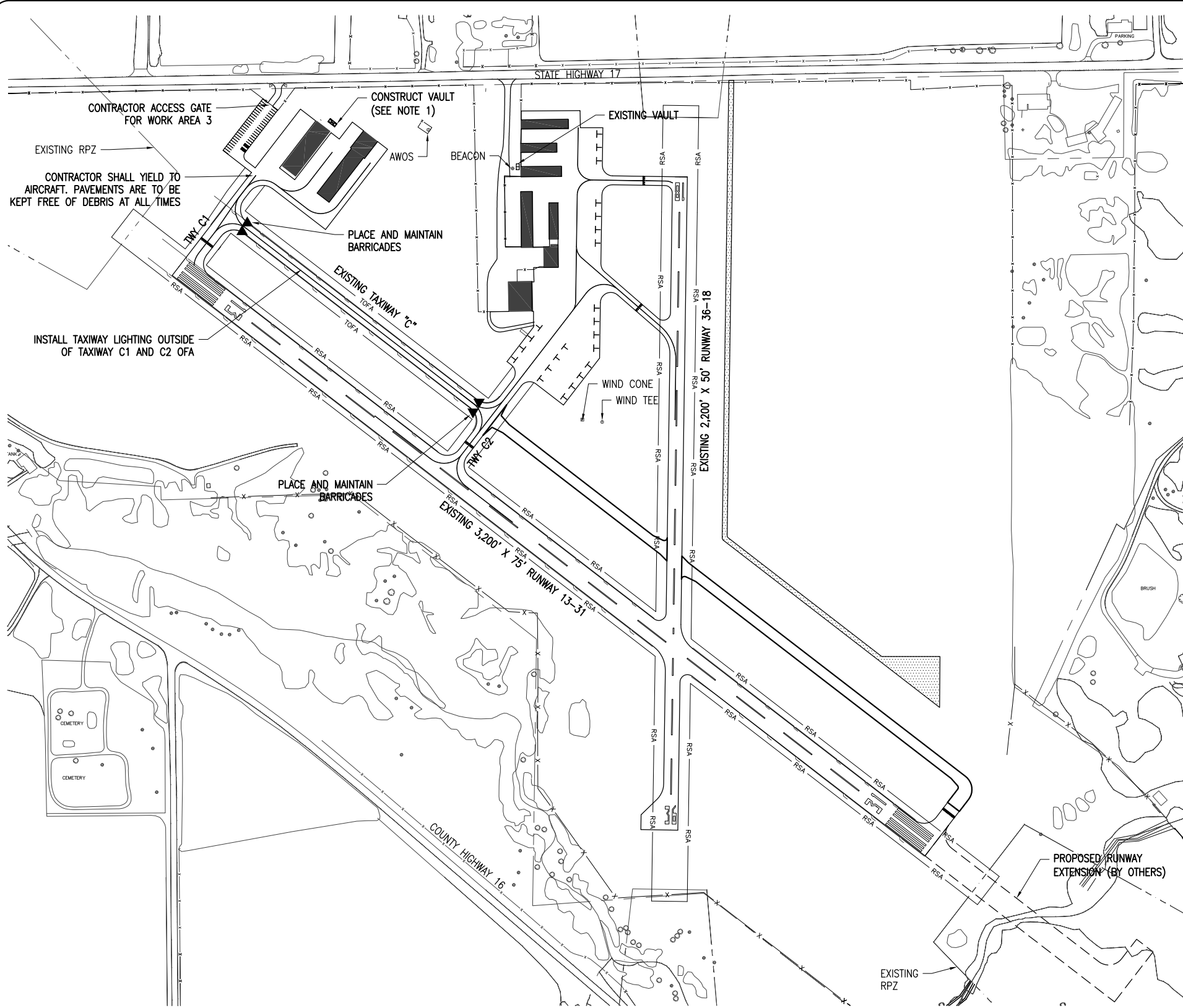

WORK AREA 3 NOTES

1. THE WORK ITEMS TO BE COMPLETED IN AREA 3 INCLUDE THE REPLACEMENT OF TAXIWAY EDGE LIGHTING ALONG THE EXISTING PORTION OF TAXIWAY "C", OUTSIDE OF THE TAXIWAY "C-1" AND "C-2" OBJECT FREE AREA LIMITS. IT IS ALSO ANTICIPATED THAT CONSTRUCTION OF THE PROPOSED ELECTRICAL VAULT MAY OCCUR CONCURRENTLY WITH OTHER SCOPE ITEMS IN MULTIPLE WORK AREAS THROUGH COORDINATION WITH THE OWNER AND RESIDENT ENGINEER. THEREFORE THE VAULT WORK IS EXCLUDED FROM THE INDIVIDUAL WORK AREA CONTRACT TIME DURATIONS, BUT SHALL BE COMPLETED WITHIN THE OVERALL PROJECT CONTRACT TIME.
2. THE CONTRACTOR SHALL HAVE A MAXIMUM OF 7 CONSECUTIVE CALENDAR DAYS TO COMPLETE THE WORK IN THIS AREA.
3. CLOSURE CROSSES AND BARRICADES SHALL BE IN PLACE PRIOR TO BEGINNING CONSTRUCTION.
4. AT ALL TIMES, THE CONTRACTOR'S OPERATIONS SHALL BE SUCH AS TO MINIMIZE CLOSURES.
5. THE CONTRACTOR MAY WORK IN AREAS 2 AND 3 SIMULTANEOUSLY. HOWEVER, CONTRACT TIME PROVISIONS SHALL STILL BE ENFORCED FOR EACH AREA.

LEGEND

- EXISTING IMPROVEMENTS
- PROPOSED IMPROVEMENTS
- FUTURE IMPROVEMENTS
- EXISTING BUILDINGS
- PROPOSED HAUL ROUTE AND EQUIPMENT PARKING AREA
- RUNWAY SAFETY AREA (120' WIDE)
- TAXIWAY OBJECT FREE AREA (89' WIDE)
- RUNWAY PROTECTION ZONE
- PROPOSED RUNWAY/TAXIWAY CLOSURE CROSS
- PROPOSED BARRICADES

JAN 11, 2013 1:14 PM HARR01115 pw:\s\spi-svr306.hanson.com\Hanson Projects\Documents\09jobs\09A0031\09A0031D\CAD\Airport\Sheet\C-006-SFY

REVISION	DATE

MARSHALL COUNTY AIRPORT
LACON, ILLINOIS

IL PROJ.: C75-4218 BLOCK GRANT: 3-17-0059-B14

Hanson Project No.	09A0031
Filename	C-006-SFY.dwg
Scale	1" = 200'
Date	01/11/13
LAYOUT	BAK 08/07/12
DRAWN	BAK 08/07/12
REVIEWED	BSS 01/11/13



© Copyright Hanson Professional Services Inc. 2013
Hanson Professional Services Inc.
1525 North State Street
Springfield, Illinois 62703-2886

CONSTRUCT A 2,065' X 35'
PARTIAL PARALLEL TAXIWAY
TO RUNWAY 13/31

PROPOSED SAFETY AND
PHASING PLAN-WORK AREA 3

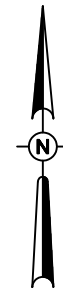

0' 100' 200' 400'
 HALF SIZE SCALE: 1" = 400'
 FULL SIZE SCALE: 1" = 200'

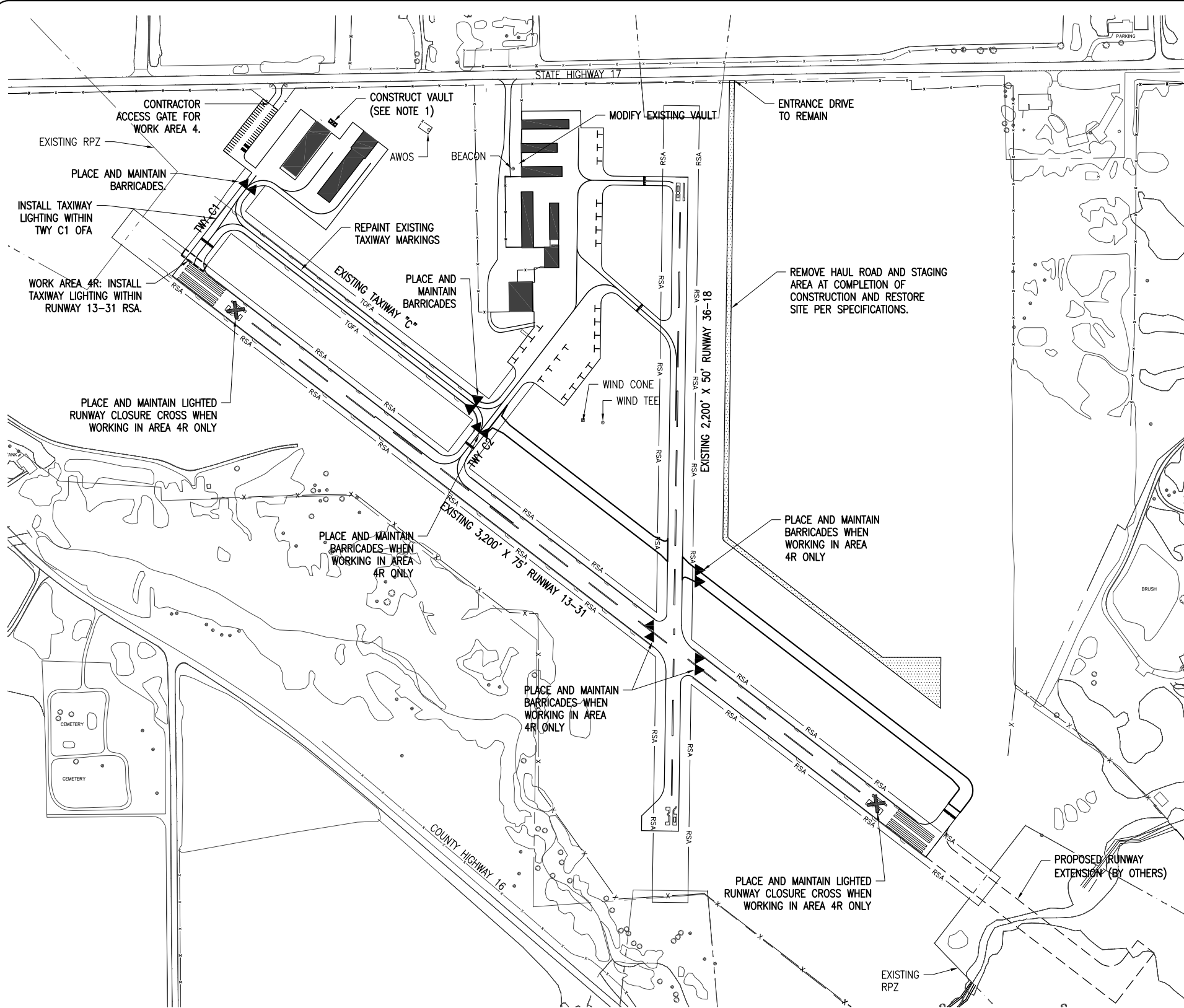

WORK AREA 4 NOTES

1. THE WORK ITEMS TO BE COMPLETED IN AREA 4 INCLUDE REPAINTING EXISTING TAXIWAY MARKINGS, REPLACEMENT OF TAXIWAY EDGE LIGHTING WITHIN THE TAXIWAY "C-1" OBJECT FREE AREA LIMITS, INSTALLING DUCTS AT THE TAXIWAY "C-1"/T-HANGAR INTERSECTION, AND OTHER ASSOCIATED ELECTRICAL ITEMS. IT IS ALSO ANTICIPATED THAT CONSTRUCTION OF THE PROPOSED ELECTRICAL VAULT MAY OCCUR CONCURRENTLY WITH OTHER SCOPE ITEMS IN MULTIPLE WORK AREAS THROUGH COORDINATION WITH THE OWNER AND RESIDENT ENGINEER. THEREFORE THE VAULT WORK IS EXCLUDED FROM THE INDIVIDUAL WORK AREA CONTRACT TIME DURATIONS, BUT SHALL BE COMPLETED WITHIN THE OVERALL PROJECT CONTRACT TIME.
2. THE CONTRACTOR SHALL HAVE A MAXIMUM OF 10 CONSECUTIVE CALENDAR DAYS TO COMPLETE THE WORK IN THIS AREA, INCLUSIVE OF WORK AREA 4R.
3. CLOSURE CROSSES AND BARRICADES SHALL BE IN PLACE PRIOR TO BEGINNING CONSTRUCTION.
4. AT ALL TIMES, THE CONTRACTOR'S OPERATIONS SHALL BE SUCH AS TO MINIMIZE CLOSURES.
5. THE CONTRACTOR MAY WORK IN AREAS 4 AND 4R SIMULTANEOUSLY. HOWEVER, CONTRACT TIME PROVISIONS SHALL STILL BE ENFORCED FOR EACH AREA.

WORK AREA 4R NOTES

1. THE WORK ITEMS TO BE COMPLETED IN AREA 4R INCLUDE REPLACEMENT OF TAXIWAY EDGE LIGHTING WITHIN THE RUNWAY 13-31 SAFETY AREA LIMITS.
2. THE CONTRACTOR SHALL HAVE A MAXIMUM OF 1 CALENDAR DAY TO COMPLETE THE WORK IN THIS AREA. THIS WORK SHALL BE ACCOMPLISHED BETWEEN MONDAY AND FRIDAY OF A GIVEN WEEK, TO BE COORDINATED WITH THE OWNER AND ENGINEER.
3. CLOSURE CROSSES AND BARRICADES SHALL BE IN PLACE PRIOR TO BEGINNING CONSTRUCTION.
4. RUNWAY 13-31 SHALL BE NOTAMED "CLOSED". THE PAPIS AND REILS SHALL BE NOTAMED "SHUTDOWN". WHENEVER THE RUNWAY IS CLOSED, ALL ASSOCIATED LIGHTING SHALL BE TURNED OFF OR COMPLETELY COVERED, INCLUDING THE RUNWAY EDGE LIGHTS, PAPIS AND REILS. CONTRACTOR SHALL COORDINATE WITH THE AIRPORT AT LEAST 48 HOURS BEFORE WORKING WITHIN THE RUNWAY SAFETY AREAS SO THAT NOTAMS MAY BE COORDINATED.
5. AT ALL TIMES, THE CONTRACTOR'S OPERATIONS SHALL BE SUCH AS TO MINIMIZE CLOSURES.
6. THE CONTRACTOR MAY WORK IN AREAS 4 AND 4R SIMULTANEOUSLY. HOWEVER, CONTRACT TIME PROVISIONS SHALL STILL BE ENFORCED FOR EACH AREA.
7. THE CONTRACTOR MAY WORK IN AREAS 2R AND 4R SIMULTANEOUSLY. HOWEVER, CONTRACT TIME PROVISIONS SHALL STILL BE ENFORCED FOR EACH AREA.

LEGEND

- EXISTING IMPROVEMENTS
- PROPOSED IMPROVEMENTS
- FUTURE IMPROVEMENTS
- EXISTING BUILDINGS
- PROPOSED HAUL ROUTE AND EQUIPMENT PARKING AREA
- RSA - RUNWAY SAFETY AREA (120' WIDE)
- TOFA - TAXIWAY OBJECT FREE AREA (89' WIDE)
- RUNWAY PROTECTION ZONE
- PROPOSED RUNWAY/TAXIWAY CLOSURE CROSS
- PROPOSED BARRICADES

REVISION	DATE

MARSHALL COUNTY AIRPORT
 LACON, ILLINOIS

IL PROJ.: C75-4218 BLOCK GRANT: 3-17-0059-B14

Hanson Project No.	09A0031	LAYOUT	BAK	08/07/12
Filename	C-007-SFY.dwg	DRAWN	BAK	08/07/12
Scale	1" = 200'	REVIEWED	BSS	01/11/13
Date	01/11/13			



© Copyright Hanson Professional Services Inc. 2013
 Hanson Professional Services Inc.
 1525 S. 36th Street
 Springfield, Illinois 62703-2886

CONSTRUCT A 2,065' X 35'
 PARTIAL PARALLEL TAXIWAY
 TO RUNWAY 13/31

PROPOSED SAFETY AND
 PHASING PLAN-WORK AREA 4

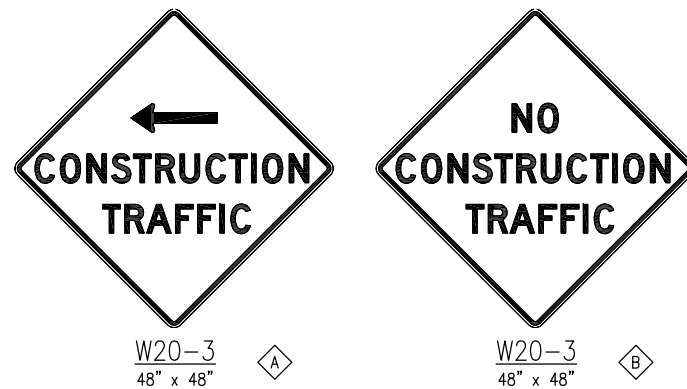

CONSTRUCTION SIGNS
NOT TO SCALE

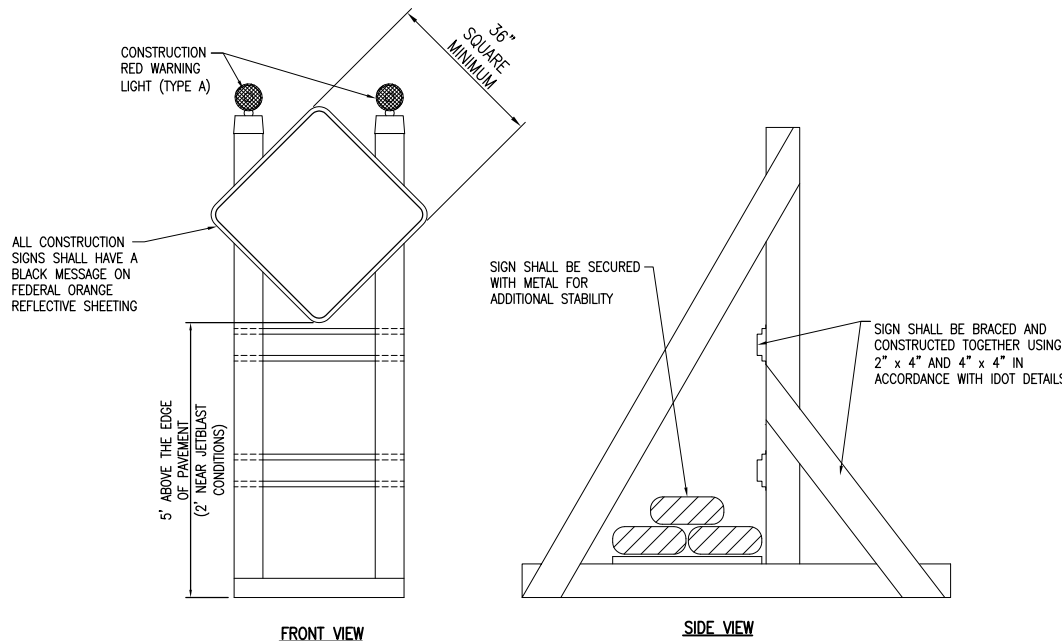

SIGNAGE NOTES

- ALL CONSTRUCTION SIGNS AND TRAFFIC CONTROL DEVICES SHALL CONFORM TO THE MANUAL ON UNIFORM TRAFFIC CONTROL DEVICES INCLUDING THE ILLINOIS SUPPLEMENT (LATEST EDITION) AND THE FAA ADVISORY CIRCULARS (LATEST EDITION) UNLESS NOTED OTHERWISE. THE FAA OR MORE STRINGENT SPECIFICATIONS SHALL GOVERN.
- UNLESS OTHERWISE SPECIFIED, CONSTRUCTION SIGNS SHALL BE MOUNTED ON PORTABLE OR NON-PORTABLE SUPPORTS. A PORTABLE SUPPORT IS DEFINED AS A TYPICAL SIGN STANDARD AS SHOWN ON THIS SHEET, OR A SMALL LIGHT WEIGHT TRAILER. A NON-PORTABLE SUPPORT IS DEFINED AS DRIVEN METAL OR WOOD POST. ALL SIGNS, REGARDLESS OF THE TYPE OF SUPPORTS USED, SHALL BE MOUNTED SUCH THAT THE MESSAGE ON THE SIGN IS LEVEL IN THE HORIZONTAL PLANE AFTER PLACEMENT. THE COST OF CONSTRUCTION WARNING LIGHTS SHALL BE INCLUDED IN THE COST OF THE CONSTRUCTION SIGNS.
- CONSTRUCTION RED WARNING LIGHT- THESE ARE PORTABLE, LENS DIRECTED, ENCLOSED LIGHTS. THE COLOR OF THE LIGHT EMITTED SHALL BE RED. THEY ARE TO BE USED IN A LOW INTENSITY FLASHING MODE (TYPE A).
- THE LIGHTING SHALL BE MAINTAINED IN OPERATION DURING THE HOURS OF DARKNESS BETWEEN 1/2 HOUR AFTER SUNSET AND 1/2 HOUR BEFORE SUNRISE AND WHEN CONDITIONS EXIST WHICH TEND TO OBSCURE VISION.
- COST FOR PLACING, MAINTAINING, AND REMOVING SIGNS SHALL BE INCLUDED IN OTHER CONTRACT ITEMS.

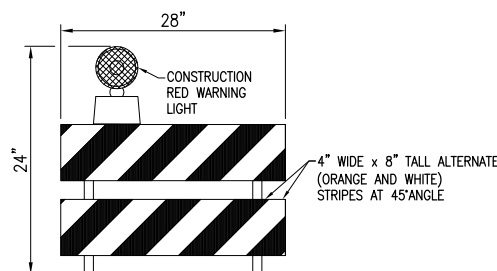

MODIFIED TYPE II BARRICADE
NOT TO SCALE

BARRICADE NOTES

- ALL CONSTRUCTION SIGNS AND TRAFFIC CONTROL DEVICES SHALL CONFORM TO THE MANUAL ON UNIFORM TRAFFIC CONTROL DEVICES INCLUDING THE ILLINOIS SUPPLEMENT (LATEST EDITION) AND THE FAA ADVISORY CIRCULARS (LATEST EDITION) UNLESS NOTED OTHERWISE. THE FAA OR MORE STRINGENT SPECIFICATIONS SHALL GOVERN.
- MODIFIED TYPE II BARRICADES SHALL BE SPACED END TO END THE WIDTH OF THE PAVEMENT IN 4' INCREMENTS AS DIRECTED BY THE ENGINEER. BARRICADES ARE TO BE SET BACK 66' FROM THE ACTIVE TAXIWAY CENTERLINE OR AS SHOWN ON THE PLANS.
- CONSTRUCTION RED WARNING LIGHT- THESE ARE PORTABLE, LENS DIRECTED, ENCLOSED LIGHTS. THE COLOR OF THE LIGHT EMITTED SHALL BE RED. THEY MAY BE USED IN EITHER A STEADY BURN (TYPE C) OR LOW INTENSITY FLASHING MODE (TYPE A) UNLESS NOTED OTHERWISE.
- THE LIGHTING SHALL BE MAINTAINED IN OPERATION DURING THE HOURS OF DARKNESS BETWEEN 1/2 HOUR AFTER SUNSET AND 1/2 HOUR BEFORE SUNRISE AND WHEN CONDITIONS EXIST WHICH TEND TO OBSCURE VISION.
- BARRICADES SHALL BE SECURED TO THE GROUND BY APPROVED METHODS TO PREVENT MOVEMENT BY PROP WASH, JET BLAST OR OTHER WIND CURRENTS.
- THE ONLY COLOR COMBINATION ON TYPE II BARRICADES IS ORANGE AND WHITE. THE ORANGE STRIPES SHALL BE ENCAPSULATED LENS REFLECTIVE SHEETING. THE WHITE STRIPES SHALL BE EITHER ENCAPSULATED OR ENCLOSED LENS REFLECTIVE SHEETING AND MUST BE IN ACCEPTABLE CONDITION.
- COST FOR PLACING, MAINTAINING, AND REMOVING BARRICADES SHALL BE INCLUDED IN OTHER CONTRACT ITEMS.



- TEMPORARY CLOSURE CROSS MARKINGS SHALL BE "AVIATION YELLOW."
- TEMPORARY CLOSURE CROSS MARKINGS SHALL BE CONSTRUCTED OF PLYWOOD, SNOW FENCE OR APPROVED FABRIC AND SHALL BE SECURED TO PAVEMENT BY SANDBAGS OR OTHER APPROVED METHOD.
- RUNWAY CLOSURE CROSS MARKINGS SHALL BE LIGHTED DURING DARKNESS AND PERIODS OF REDUCED VISIBILITY.
- COST FOR PLACING, MAINTAINING, AND REMOVING CLOSURE CROSSES SHALL BE INCLUDED IN OTHER CONTRACT ITEMS.

CLOSURE CROSS MARKER DETAIL
(LIGHTED/UNLIGHTED)
NOT TO SCALE

SAFETY NOTES

- FOLLOWING ARE THE CONSTRUCTION SAFETY PROCEDURES THAT THE CONTRACTOR SHALL FOLLOW THROUGHOUT THIS PROJECT. ADDITIONAL REQUIREMENTS ARE SHOWN ON THE SAFETY AND PHASING NOTES AND DETAILS SHEET.
- ALL PROVISIONS OF THE LATEST EDITION OF FAA ADVISORY CIRCULAR AC 150/5370-2 (CURRENT EDITION), "OPERATIONAL SAFETY ON AIRPORTS DURING CONSTRUCTION", APPLY TO THIS CONTRACT, EXCEPT AS MODIFIED BY THIS SAFETY PLAN, OR AS MODIFIED BY THE OWNER THROUGH THE RESIDENT ENGINEER AT THE PRECONSTRUCTION CONFERENCE, OR DURING THE COURSE OF THE CONTRACT.
- THE CONTRACTORS SHALL MINIMIZE DISRUPTION OF STANDARD OPERATING PROCEDURES FOR AERONAUTICAL ACTIVITY BY REMAINING WITHIN THE PRESCRIBED STAGING, CONSTRUCTION, AND PHASING AREAS PRESENTED ON THE PROJECT SAFETY AND PHASING PLANS.
- NO UNAUTHORIZED PERSONNEL SHALL ENTER ANY AREA OF THE AIRPORT THAT COULD POTENTIALLY BE HAZARDOUS. THE ENGINEER, ENGINEER'S REPRESENTATIVE AND/OR AIRPORT MANAGER RESERVE THE RIGHT TO SUSPEND OPERATIONS IN ORDER TO MAINTAIN SAFETY AT THE AIRPORT.
- CONTRACTOR EQUIPMENT, VEHICLES, AND PROJECT MATERIALS SHALL BE STORED AT THE STAGING AREA SHOWN ON THE PLAN VIEW, EXCEPT AS OTHERWISE PROVIDED FOR AT THE PRECONSTRUCTION CONFERENCE.
- ALL CONSTRUCTION EQUIPMENT OPERATING IN THE PRESCRIBED CONSTRUCTION AREA IS REQUIRED TO DISPLAY A CHECKERBOARD FLAG PROPERLY LOCATED OR A ROTATING BEACON (STROBE) AS SPECIFIED IN AC 150/5210-5, "PAINTING, MARKING, AND LIGHTING OF VEHICLES USED ON AN AIRPORT" LATEST EDITION.
- NO CONSTRUCTION MATERIAL STOCKPILES SHALL BE LOCATED WITHIN 200' OF ANY ACTIVE RUNWAY, WITHIN 50' OF ANY OTHER ACTIVE AIRPORT OPERATIONS AREA, OR PENETRATE A PART 77 IMAGINARY SURFACE (PROVIDED BY THE ENGINEER) EXTENDING OUT AND UPWARDS FROM ALL SIDES OF AN ACTIVE RUNWAY.
- CLOSED AIRFIELD PHASING AREAS, OPEN TRENCHES, AND STOCKPILED MATERIALS AT THE CONSTRUCTION SITE SHALL BE PROMINENTLY MARKED WITH LIGHTED BARRICADES WITH STEADY BURNING OR FLASHING RED LIGHTS AS SPECIFIED IN 150/5370-2, "OPERATIONAL SAFETY ON AIRPORT DURING CONSTRUCTION, LATEST EDITION. LIGHTED BARRICADES MUST BE NO TALLER THAN 18" (EXCLUSIVE OF SUPPLEMENTARY LIGHTS AND FLAGS) ON THE TAXIWAYS AND COMPLY WITH ADVISORY CIRCULAR 150/5370-2, LATEST EDITION. CONTRACTOR SHALL NIGHT CHECK BARRICADES DAILY FOR PROPER OPERATION.
- NO OPEN TRENCHES WITHIN 200' OF AN ACTIVE RUNWAY CENTERLINE OR WITHIN 50' OF ANY AIRPORT OPERATIONS AREA WILL BE PERMITTED UNLESS PROPERLY MARKED. OTHER TRENCHES SHALL BE MAINTAINED SAFE, I.E., BARRICADED OR COVERED WITH STEEL PLATES IN ALL OTHER AREAS.
- OPEN TRENCHES, EXCAVATIONS, AND STOCKPILED MATERIALS AT THE CONSTRUCTION SITE SHOULD BE PROMINENTLY MARKED WITH ORANGE FLAGS AND LIGHTED WITH FLASHING YELLOW LIGHTS DURING HOURS OF RESTRICTED VISIBILITY AND/OR DARKNESS.
- NO CONSTRUCTION EQUIPMENT GREATER THAN 23' TALL WILL BE PERMITTED ON THE AIRPORT. HOWEVER OTHER EQUIPMENT TALLER THAN 23' MAY BE PERMITTED WITH THE APPROVAL OF THE AIRPORT MANAGER AND AIRSPACE APPROVAL BY THE FAA.
- NO OPEN FLAME WELDING OR TORCH CUTTING OPERATION IS PERMITTED UNLESS ADEQUATE FIRE AND SAFETY PRECAUTIONS ARE PROVIDED AND HAVE BEEN APPROVED BY THE AIRPORT MANAGER. NO FLARE POTS ARE ALLOWED ON THE PROJECT.
- SOIL, DEBRIS, AND LOOSE MATERIAL DROPPED OR TRUCKED ONTO AIRPORT ROADS, TAXIWAYS, AND SOD SURFACES, OR WHICH CAN BE BLOWN ONTO SUCH SURFACES, SHALL BE IMMEDIATELY SWEEP, PICKED UP AND REMOVED, OR PLACED INTO CLOSED CONTAINERS. ANY DAMAGE TO AIRPORT PROPERTY SHALL BE REPAIRED IMMEDIATELY AT NO COST TO THE OWNER.
- EACH CONTRACTOR SHALL BE RESPONSIBLE FOR LOCATING AND MAINTAINING AIRPORT LIGHTING AND NAVIGATIONAL ELECTRICAL SYSTEMS DURING CONSTRUCTION. A CONTACT PERSON AND TELEPHONE NUMBER FOR 24 HOUR EMERGENCY IMMEDIATE REPAIR SHALL BE SUBMITTED TO THE AIRPORT MANAGER AND ENGINEER. HAUL ROUTES CROSSING PAVEMENT, DRAINAGE, MISCELLANEOUS STRUCTURES AND/OR AIRFIELD CABLES SHALL BE PROTECTED FROM DAMAGE.
- ALL AIRCRAFT AND AIRPORT OPERATIONS HAVE THE RIGHT-OF-WAY. CONTRACTOR TO YIELD TO VEHICLES AND REMAIN CLEAR AT ALL TIMES.
- CONTRACTOR SHALL PLACE, SECURE, AND MAINTAIN LIGHTED BARRICADES AND CLOSURE CROSSES WHEN A RUNWAY/TAXIWAY/APRON IS CLOSED OR AS REQUIRED BY THE PLANS AND DESIGNATED BY THE ENGINEER.
- CONTRACTOR SHALL MARK HAZARDOUS AREA WITH STEADY-BURNING OR FLASHING RED AND YELLOW LIGHTS DURING PERIODS OF LOW VISIBILITY AS REQUIRED.
- THE CONTRACTOR SHALL PERIODICALLY PERFORM ONSITE INSPECTIONS THROUGHOUT THE DURATION OF THE PROJECT WITH THE IMMEDIATE REMEDY OF ANY DIFFERENCES, WHETHER CAUSED BY NEGLIGENCE, OVERSIGHT, OR PROJECT SCOPE CHANGE.
- CONTRACTOR SHALL MOVE MAINTENANCE OF TRAFFIC COMPONENTS AT THE WRITTEN DIRECTION OF THE ENGINEER AT NO ADDITIONAL COST.
- CONTRACTOR SHALL NOT REMOVE THE BARRICADES WITHOUT THE APPROVAL BY THE ENGINEER.
- CONTRACTOR SHALL MAINTAIN FLASHERS, SIGNS AND/OR BARRICADES AS REQUIRED BY THE PLANS, CITY OR COUNTY REGULATIONS OR CONTRACTOR ACTIVITIES. CONTRACTOR SHALL OBTAIN ANY AND ALL REQUIRED LOCAL PERMITS UNLESS SPECIFIED OTHERWISE.
- THE CONTRACTOR SHALL UTILIZE WATER AND/OR CHEMICALS APPROVED BY THE ENGINEER AS NECESSARY TO CONTROL DUST.
- NO CONSTRUCTION VEHICLES SHALL BE DRIVEN ACROSS ANY ACTIVE RUNWAY, INCLUDING TURF RUNWAYS. CONSTRUCTION EQUIPMENT OR CONSTRUCTION ACTIVITY WILL NOT BE PERMITTED WITHIN 200' OF ANY ACTIVE RUNWAY CENTERLINE OR WITHIN 50' OF ANY OTHER ACTIVE AIRPORT TAXIWAY OR APRON. HOWEVER, CONSTRUCTION MAY BE PERMITTED IN THESE AREAS IF THE CONTRACTOR HAS GAINED APPROVAL FROM THE AIRPORT MANAGER AT LEAST 72 HOURS IN ADVANCE OF THE SCHEDULED CONSTRUCTION PERIOD AND THE OPERATIONAL AREA IS CLOSED TO TRAFFIC AND PROPER NOTAMS ARE ISSUED BY THE AIRPORT MANAGER TO THE APPROPRIATE FLIGHT SERVICE STATION.
- CONTRACTOR MAY WORK WITHIN OFZ WITHOUT PLACING RUNWAY CLOSED MARKERS IF HE CAN DEMONSTRATE THAT THE OFZ CAN BE CLEARED OF ALL MEN, EQUIPMENT AND OBSTRUCTIONS WITHIN A 15 MINUTE TIME PERIOD BY MONITORING UNICOM FREQUENCY 122.8 AND CLEARING OFZ AT THE REQUEST OF PILOTS. RADIO(S) TO BE PROVIDED BY CONTRACTOR TO ALL CREWS NOT WITHIN MONITORING RANGE OF THE RADIO. (OWNER TO RESTRICT TOUCH AND GO'S DURING CONSTRUCTION WORK HOURS)
- UNLESS SPECIFIED OTHERWISE, COST FOR THE ABOVE IS TO BE CONSIDERED INCIDENTAL TO THE PROJECT. SEPARATE PAYMENT SHALL NOT BE MADE.

REVISION	
DATE	
MARSHALL COUNTY AIRPORT LACON, ILLINOIS	
BLOCK GRANT: 3-17-0059-B14	

Hanson Project No.	09A0031
Filename	C-009-SFY.dwg
Scale	NOT TO SCALE
Date	01/11/13
LAYOUT	KNL 08/16/12
DRAWN	BAK 08/16/12
REVIEWED	BSS 01/11/13

HANSON

© Copyright Hanson Professional Services Inc. 2013
Hanson Professional Services Inc.
1525 South Main Street
Springfield, Illinois 62703-2886

CONSTRUCT A 2,065' X 35'
PARTIAL PARALLEL TAXIWAY
TO RUNWAY 13/31

CONSTRUCTION SAFETY
AND PHASING DETAILS
AND NOTES

JAN 11, 2013 1:15 PM HARR01115
pw:\sps\sw306\hanson\Documents\09A0031\09A0031D\CAD\Airport\Sheet\C-009-SFY

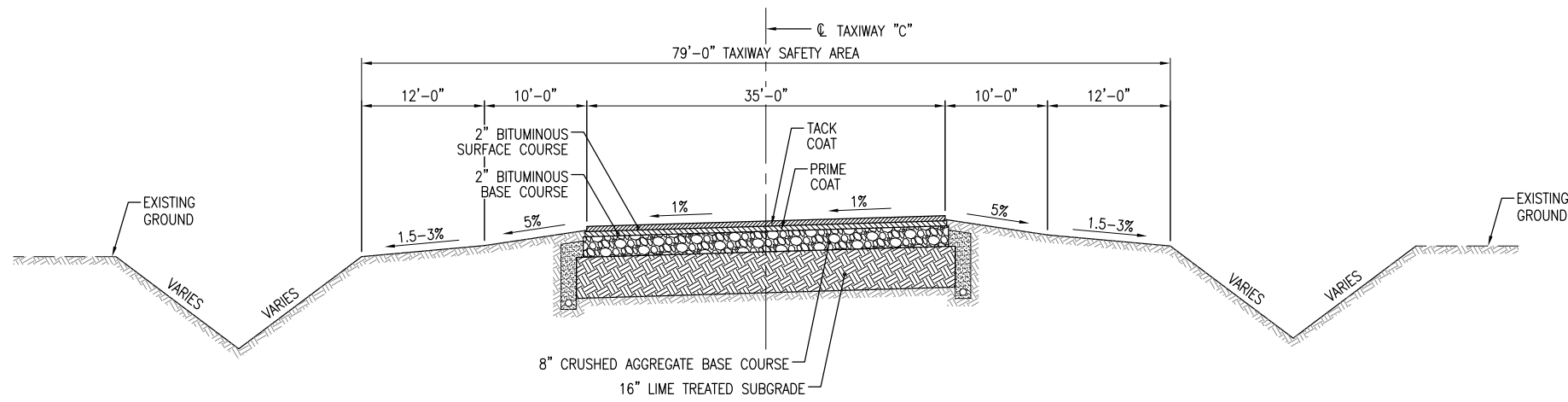

TYPICAL SUPERELEVATED SECTION - TAXIWAY "C"

NOT TO SCALE
STA. 135+00 TO STA 140+50
(SLOPES AND DIMENSIONS VARY AT INTERSECTIONS)

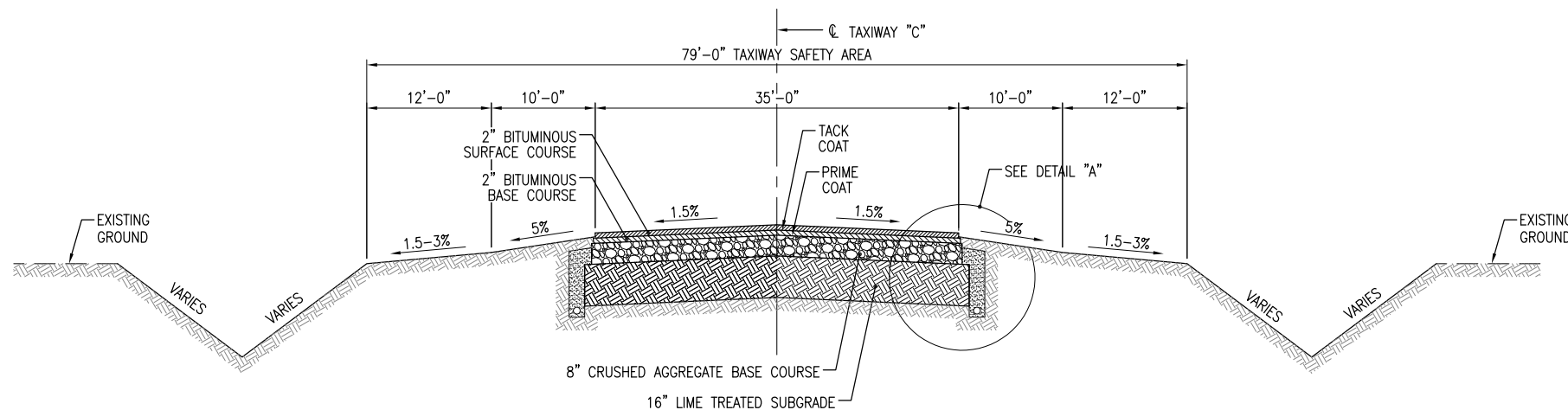

TYPICAL TANGENT SECTION - TAXIWAY "C"

NOT TO SCALE
STA. 122+00 TO STA. 131+00
(SLOPES AND DIMENSIONS VARY AT INTERSECTIONS)

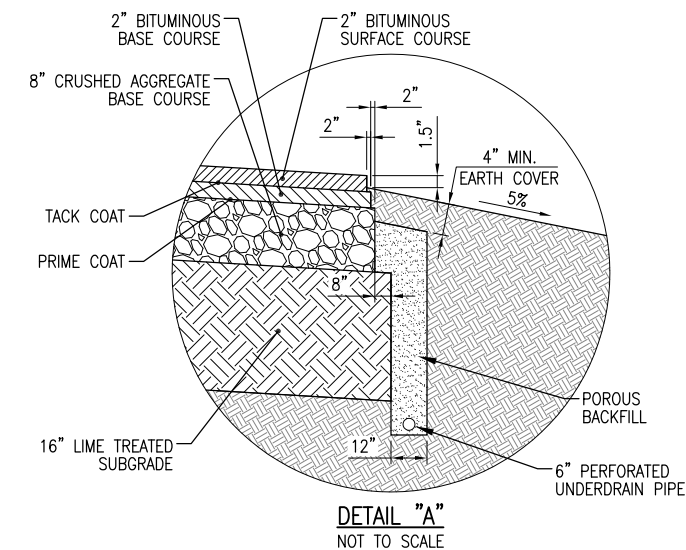

DETAIL "A"
NOT TO SCALE

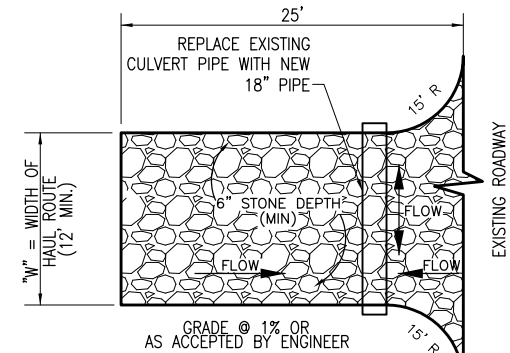

CONSTRUCTION ENTRANCE DRIVE DETAIL
NOT TO SCALE

- STONE SIZE SHALL CONFORM TO IDOT (2" TO 3" DIA.).
- CONTRACTOR SHALL PERIODICALLY PLACE 2" STONE TOP DRESSING AND WASH STONE AS REQUIRED BY OWNER/ENGINEER. INCIDENTAL WORK NOT PAID FOR DIRECTLY.
- CONTRACTOR SHALL PROVIDE ADEQUATELY SIZED PIPE AND COVER FOR CONSTRUCTION TRAFFIC VEHICLES TO MAINTAIN PROPER DRAINAGE BELOW TEMPORARY CONSTRUCTION ENTRANCE DRIVE.
- 25' LONG CONSTRUCTION ENTRANCE DRIVE IS TO REMAIN IN PLACE AT COMPLETION OF THE PROJECT.
- PAYMENT FOR ALL WORK ASSOCIATED WITH THE CONSTRUCTION ENTRANCE DRIVE IS TO BE INCLUDED IN THE COST OF AR150540 HAUL ROUTE.

REVISION	DATE

MARSHALL COUNTY AIRPORT
LACON, ILLINOIS

IL PROJ.: C75-4218 BLOCK GRANT: 3-17-0059-B14

Hanson Project No.	09A0031
Filename	C-300-TYP.dwg
Scale	NOT TO SCALE
Date	01/11/13
LAYOUT	ESC 12/03/12
DRAWN	ESC 12/03/12
REVIEWED	BSS 01/11/13



© Copyright Hanson Professional Services Inc. 2013
Hanson Professional Services Inc.
1525 South Rock Street
Springfield, Illinois 62703-2886

CONSTRUCT A 2,065' X 35'
PARTIAL PARALLEL TAXIWAY
TO RUNWAY 13/31

PROPOSED TYPICAL
SECTIONS

POINT COORDINATE DATA				
POINT #	NORTHING	EASTING	STATION	OFFSET
1	1585252.960	2513036.476	121+50.25	88.77' LT
2	1585222.427	2513076.071	121+00.25	88.77' LT
3	1585262.631	2513107.074	121+00.25	38.00' LT
4	1585296.522	2513063.123	121+55.75	38.00' LT
5	1585340.506	2513096.971	121+55.80	17.50' RT
6	1585296.886	2513070.349	121+50.25	33.30' LT
7	1585302.993	2513062.430	121+60.25	33.30' LT
8	1585309.650	2513069.892	121+58.40	23.47' LT
9	1585333.824	2513048.321	121+90.25	17.50' LT
10	1585996.530	2512188.929	132+75.48	17.50' LT
11	1586012.470	2512155.574	133+11.63	25.25' LT
12	1586003.447	2512151.262	133+09.53	35.02' LT
13	1586005.684	2512141.516	133+18.62	39.20' LT
14	1586004.540	2512141.253	133+18.13	40.27' LT
15	1586059.502	2512164.583	133+33.21	17.50' RT
16	1586082.304	2512142.383	133+64.72	22.00' RT
17	1586065.489	2512092.134	133+94.24	22.00' LT
18	1586088.291	2512069.934	134+25.75	17.50' LT
19	1586143.252	2512093.264	134+40.83	40.27' RT
20	1586142.109	2512093.001	134+40.34	39.20' RT
21	1586144.346	2512083.255	134+49.43	35.02' RT
22	1586135.323	2512078.943	134+47.33	25.25' RT
23	1586151.263	2512045.588	134+83.48	17.50' RT
24	1586496.976	2511539.955	140+95.00	17.50' LT
25	1586515.463	2511503.700	141+35.00	25.00' LT
26	1586488.367	2511473.334	141+42.50	65.00' LT
27	1586524.692	2511561.328	140+95.00	17.50' RT
28	1586555.057	2511534.232	141+35.00	25.00' RT
29	1586591.313	2511552.720	141+42.50	65.00' RT

- LEGEND**
- EXISTING PAVEMENT
 - EXISTING PIPE
 - EXISTING UNDERDRAIN
 - EXISTING CLEANOUTS
 - EXISTING HEADWALL
 - PROPOSED TAXIWAY PAVEMENT
 - PROPOSED UNDERDRAIN
 - PROPOSED STORM PIPE WITH END SECTIONS
 - PROPOSED DITCH FLOWLINE
 - PROPOSED CLEANOUT STRUCTURE
 - CORE DRILL PROPOSED RCP TO CONNECT PROPOSED UNDERDRAIN (U.D. INV. ELEV. 547.93) PROVIDE WATERTIGHT SEAL AT PIPE CONNECTIONS USING WATER SEALING GROUT. COST INCIDENTAL TO UNDERDRAIN.
 - CORE DRILL PROPOSED RCP TO CONNECT PROPOSED UNDERDRAIN (U.D. INV. ELEV. 548.11) PROVIDE WATERTIGHT SEAL AT PIPE CONNECTIONS USING WATER SEALING GROUT. COST INCIDENTAL TO UNDERDRAIN.

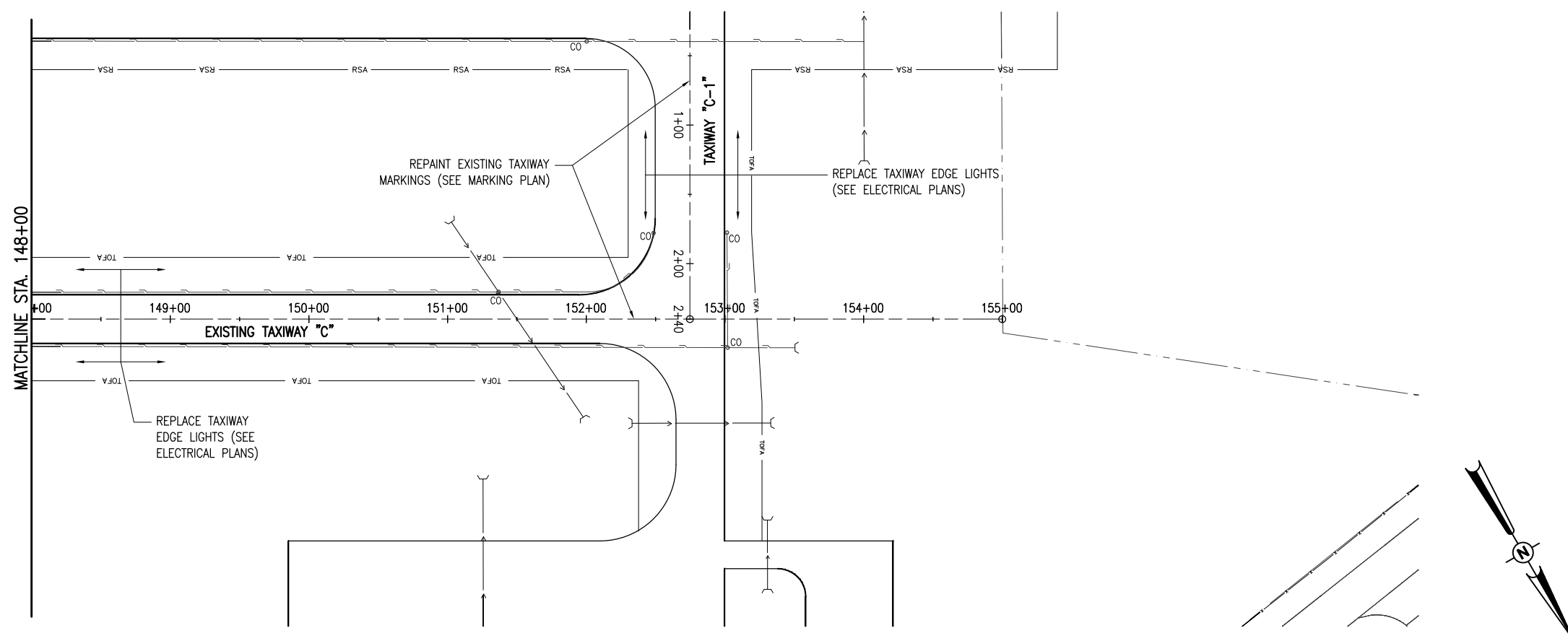
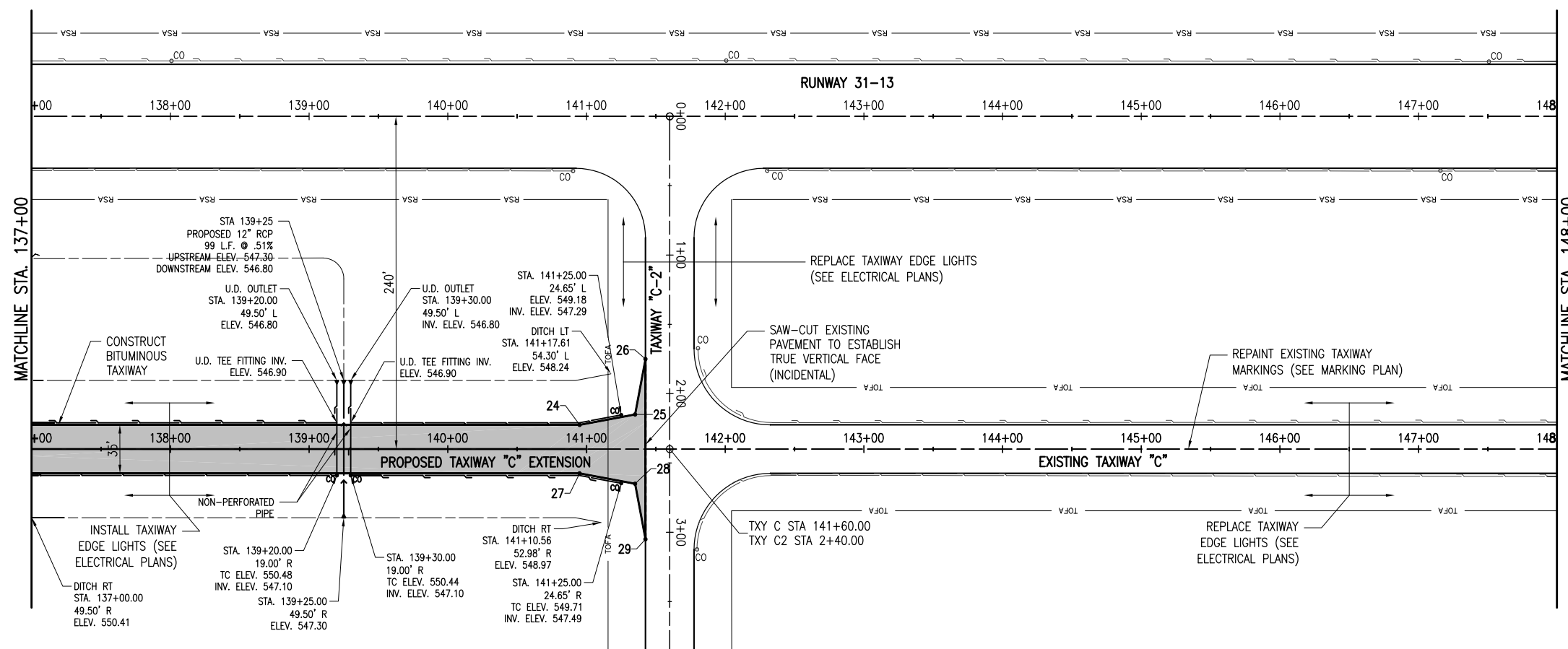
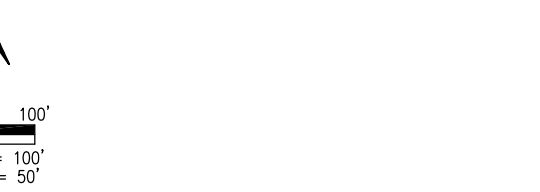

JAN 11, 2013 1:15 PM HARR01115
 p:\s\svr306\hanson\Documents\09\jobs\09A0031\09A0031D\CAD\Airport\Sheet\C-121-CONST

REVISION	
DATE	
MARSHALL COUNTY AIRPORT LACON, ILLINOIS	
BLOCK GRANT: 3-17-0059-B14	
IL PROJ.: C75-4218	

Hanson Project No.	09A0031
Filename	C-121-CONST.dwg
Scale	1" = 50'
Date	01/11/13
LAYOUT	BAK 08/07/12
DRAWN	BAK 08/07/12
REVIEWED	888 01/11/13

HANSON

Copyright Hanson Professional Services Inc. 2013
 Hanson Professional Services Inc.
 1525 South Main Street
 Springfield, Illinois 62703-2886

CONSTRUCT A 2,065' X 35'
 PARTIAL PARALLEL TAXIWAY
 TO RUNWAY 13/31
 CONSTRUCTION PLAN -
 STA. 137+00 TO STA. 148+00

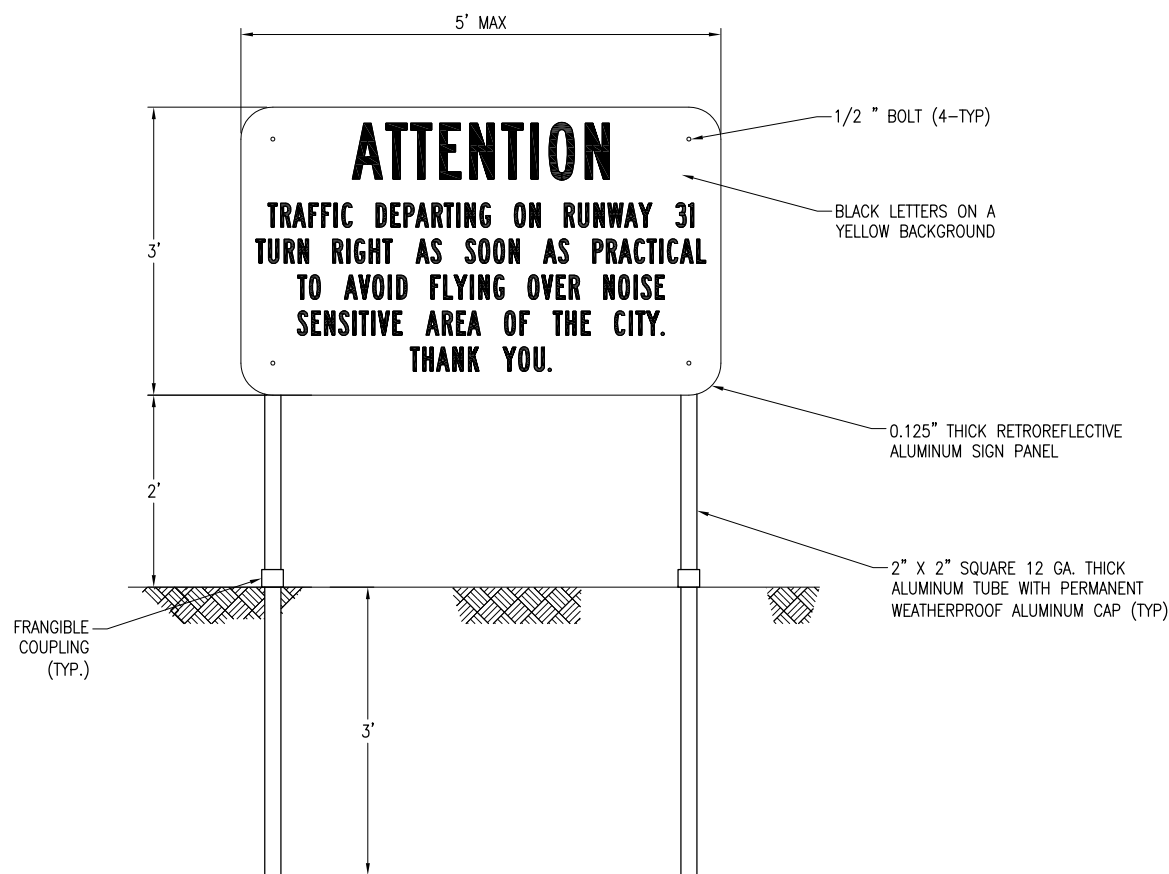

INFORMATION SIGN
NO SCALE

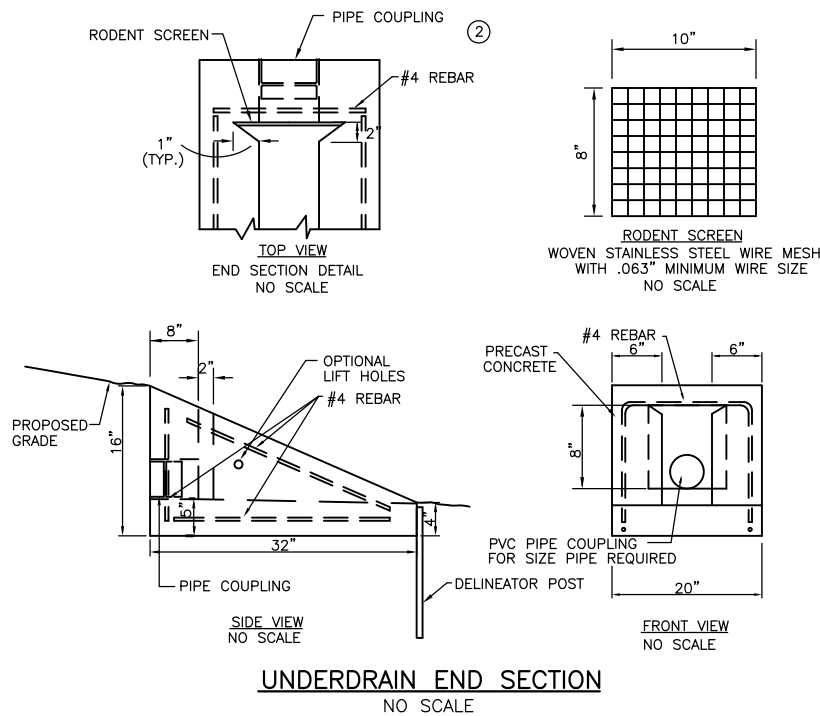

UNDERDRAIN END SECTION
NO SCALE

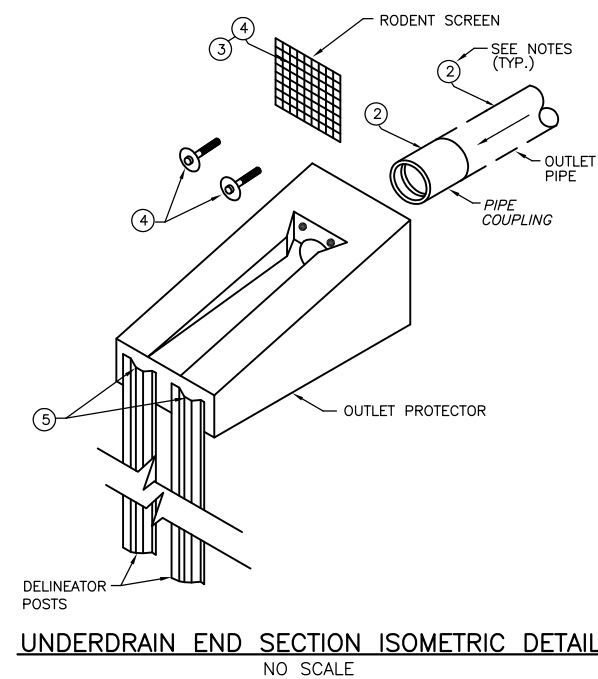

UNDERDRAIN END SECTION ISOMETRIC DETAIL
NO SCALE

UNDERDRAIN END SECTION NOTES:

1. ALL MATERIALS AND WORKMANSHIP SHALL BE IN ACCORDANCE WITH THE SPECIFICATIONS.
2. ALL PIPE AND PIPE FITTINGS SHALL CONFORM TO 6" I.D. PVC CORRUGATED SEWER PIPE WITH A SMOOTH INTERIOR FOR UNDERDRAIN OUTLETS AND 2" DIAMETER PVC SCHEDULE 40 DRAIN PIPE FOR HANDHOLE OUTLETS.
3. RODENT SCREEN SHALL BE 1/3" SQUARE (3 OPENINGS PER INCH).
4. THE RODENT SCREEN SHALL BE THE SIZE AND SHAPE AS SHOWN ON THE DETAILS. IT SHALL BE FASTENED TO THE OUTLET PROTECTOR WITH TWO 1/4" BY 1" HEX HEAD LAG SCREWS WITH FLAT WASHERS AND ANCHORS. THE APPROXIMATE LOCATION OF THE ANCHOR HOLES SHALL BE AS SHOWN ON THE DETAILS.
5. THE DELINEATOR POSTS USED TO ANCHOR THE OUTLET PROTECTOR SHALL BE EMBEDDED A MINIMUM OF 2'. THE EXPOSED END OF THESE DELINEATOR POSTS SHALL NOT PROTRUDE ABOVE THE TOP EDGE OF THE DOWNSTREAM END OF THE OUTLET PROTECTOR.

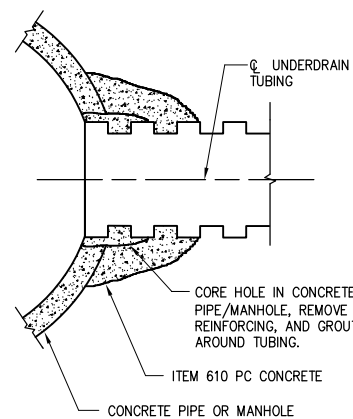

STORM SEWER CONCRETE COLLAR AND GROUT CONNECTION
NO SCALE

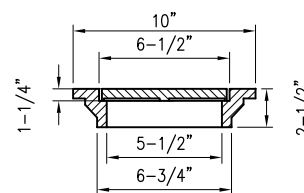

CAST IRON FRAME AND COVER

NEENAH R-6013, DEETER 1810,
EAST JORDAN 2790-6 OR
APPROVED EQUAL

CLEANOUT NOTES

DIAMETER OF PIPE AS SPECIFIED.

TOP OF CLEANOUTS SHALL BE 2" ABOVE FINISH GROUND LINE AT LOCATION SHOWN ON PLANS.

1/2" CHAMFER TO BE USED ON ALL EXPOSED EDGES OF CLEANOUTS.

THE CONCRETE SHALL BE STRUCTURAL PORTLAND CEMENT CONCRETE (NON- REINFORCED) IN ACCORDANCE WITH ITEM 610.

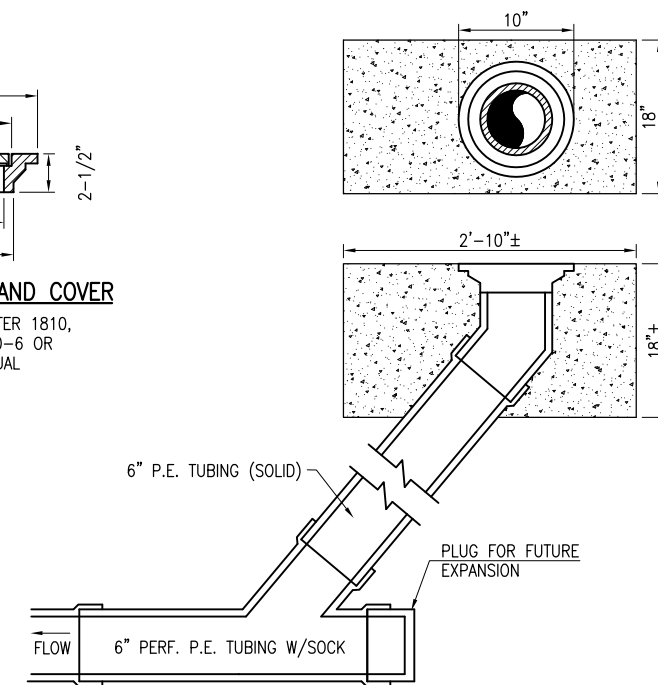

UNDERDRAIN CLEANOUT TYPE B
NO SCALE

REVISION	DATE

MARSHALL COUNTY AIRPORT
LACON, ILLINOIS

IL PROJ.: C75-4218 BLOCK GRANT: 3-17-0059-B14

Hanson Project No.	09A0031	LAYOUT	12/03/12
Filename	C-501-DETL.dwg	ESC	12/03/12
Scale	NOT TO SCALE	DRAWN	12/03/12
Date	01/11/13	REVIEWED	01/11/13



© Copyright Hanson Professional Services Inc. 2013
Hanson Professional Services Inc.
1525 South Main Street
Springfield, Illinois 62703-2886

CONSTRUCT A 2,065' X 35'
PARTIAL PARALLEL TAXIWAY
TO RUNWAY 13/31

MISCELLANEOUS
CONSTRUCTION DETAILS

JAN 11, 2013 2:59 PM HARR01115
 pw:\s\3\06\hanson\Documents\09\jobs\09A0031\09A0031D\CAD\Airport\Sheet\C-701-Plan-Profile

MA026

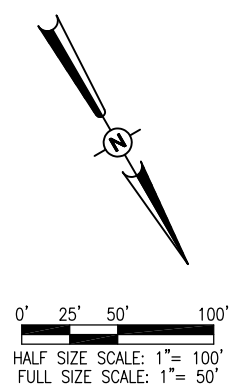
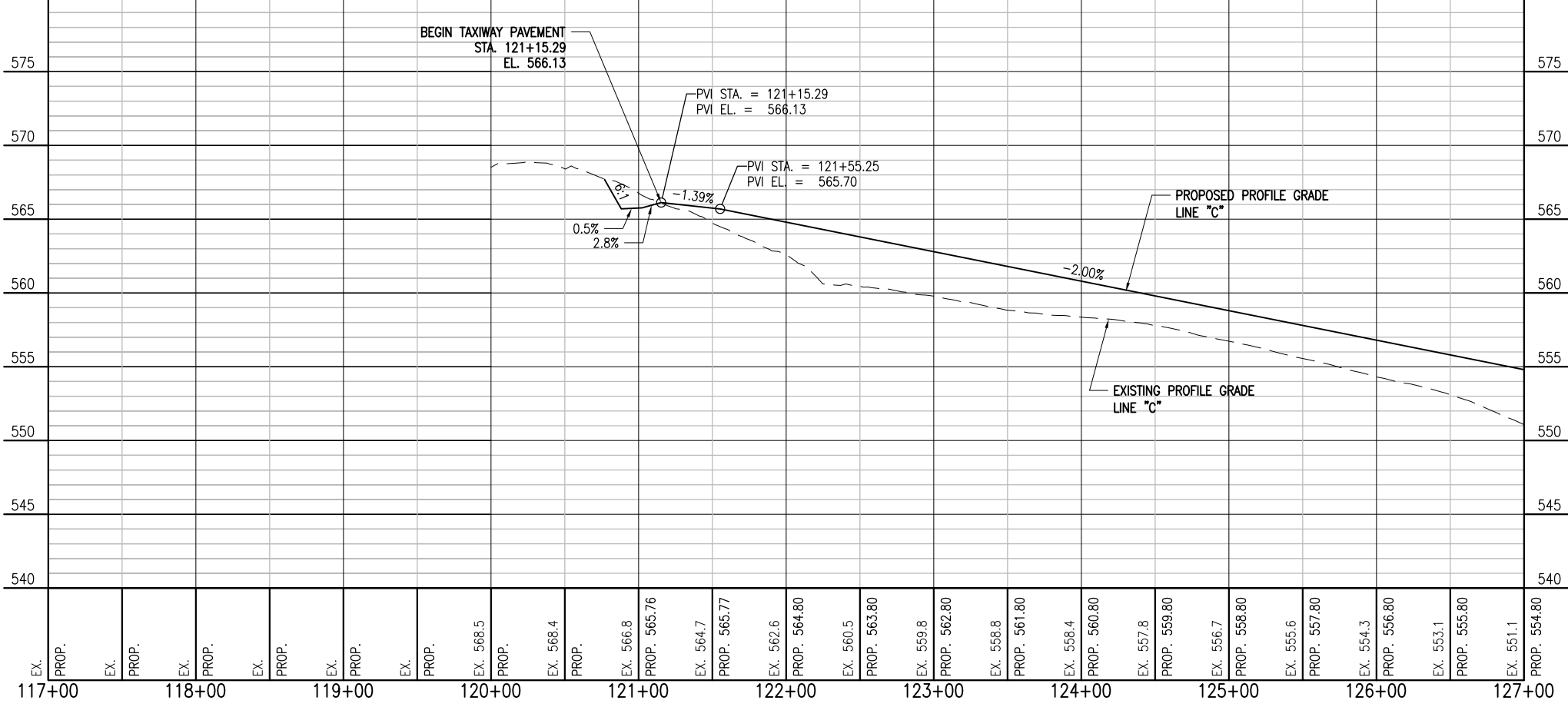
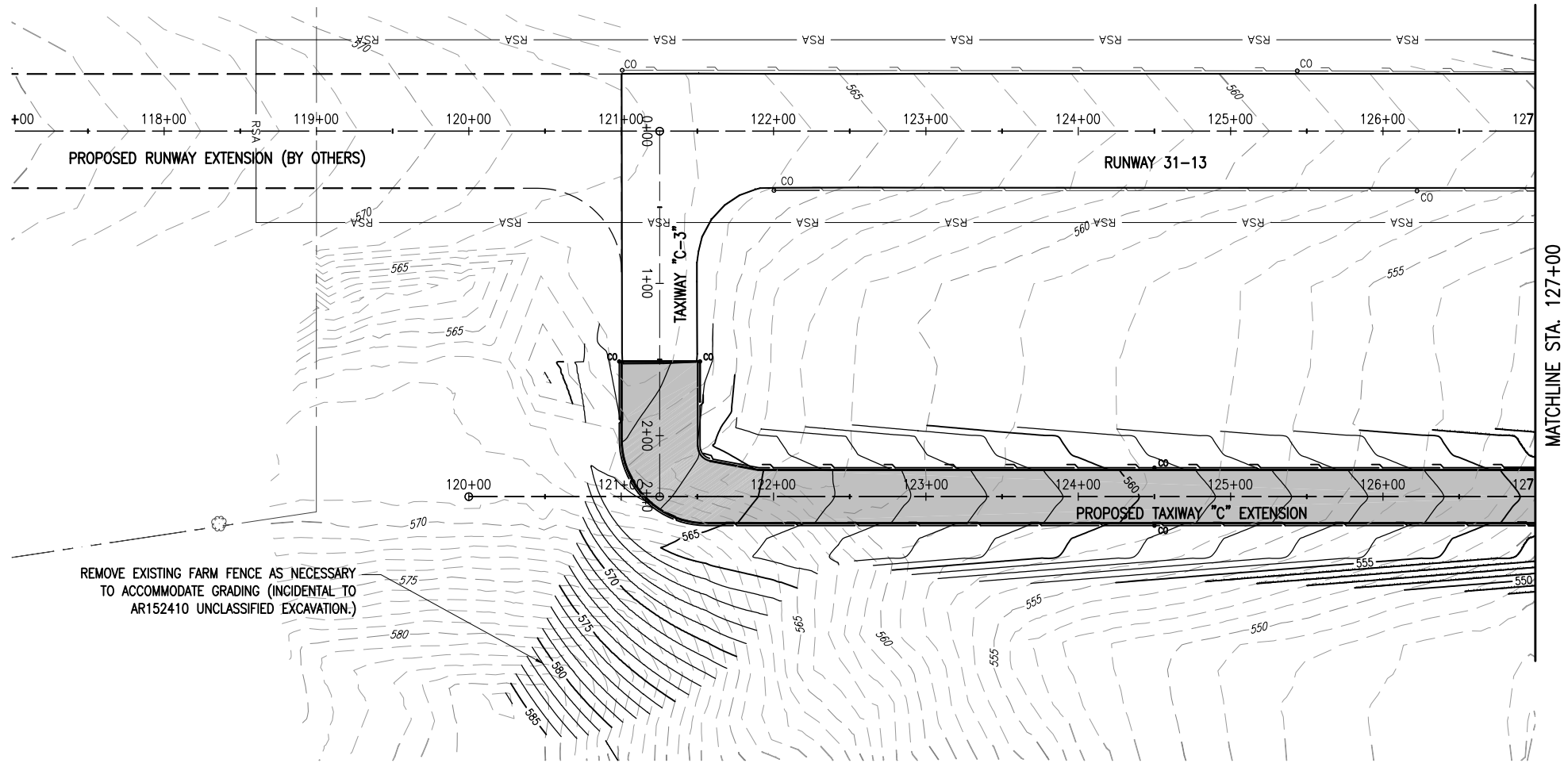

REVISION		DATE	
MARSHALL COUNTY AIRPORT LACON, ILLINOIS			
Hanson Project No. 09A0031		LAYOUT BAK 08/07/12	
Filename C-701-Plan-Profile.dwg		DRAWN BAK 08/07/12	
Scale 1" = 50'H 1" = 5'V		REVIEWED BSS 01/11/13	
Date 01/11/13			
HANSON		© Copyright Hanson Professional Services Inc. 2013 Hanson Professional Services Inc. 1525 South Lincoln Street Springfield, Illinois 62703-2886	
CONSTRUCT A 2,065' X 35' PARTIAL PARALLEL TAXIWAY TO RUNWAY 13/31		PLAN AND PROFILE - STA. 117+00 TO STA. 127+00	
14		14 of 79 sheets	

IL PROJ.: C75-4218 BLOCK GRANT: 3-17-0059-B14

JAN 11, 2013 1:15 PM HARR01115
 pw:\s\3\306\hanson\Documents\09\jobs\09A0031\09A0031D\CAD\Airport\Sheet\C-701-Plan-Profile

MA026

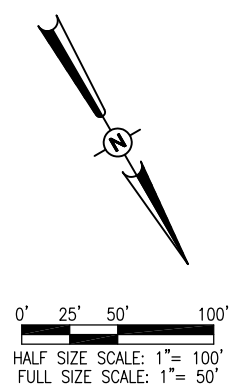
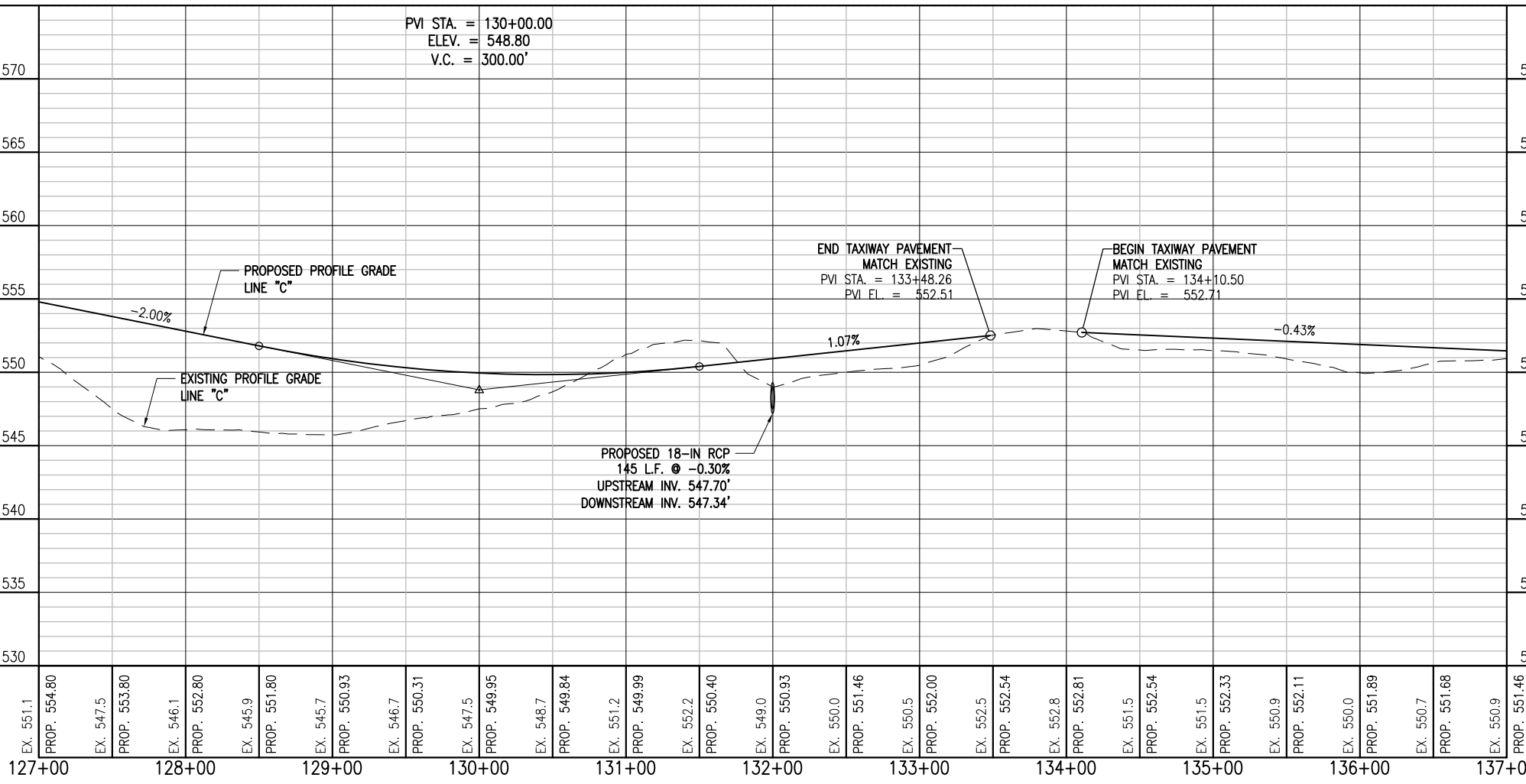
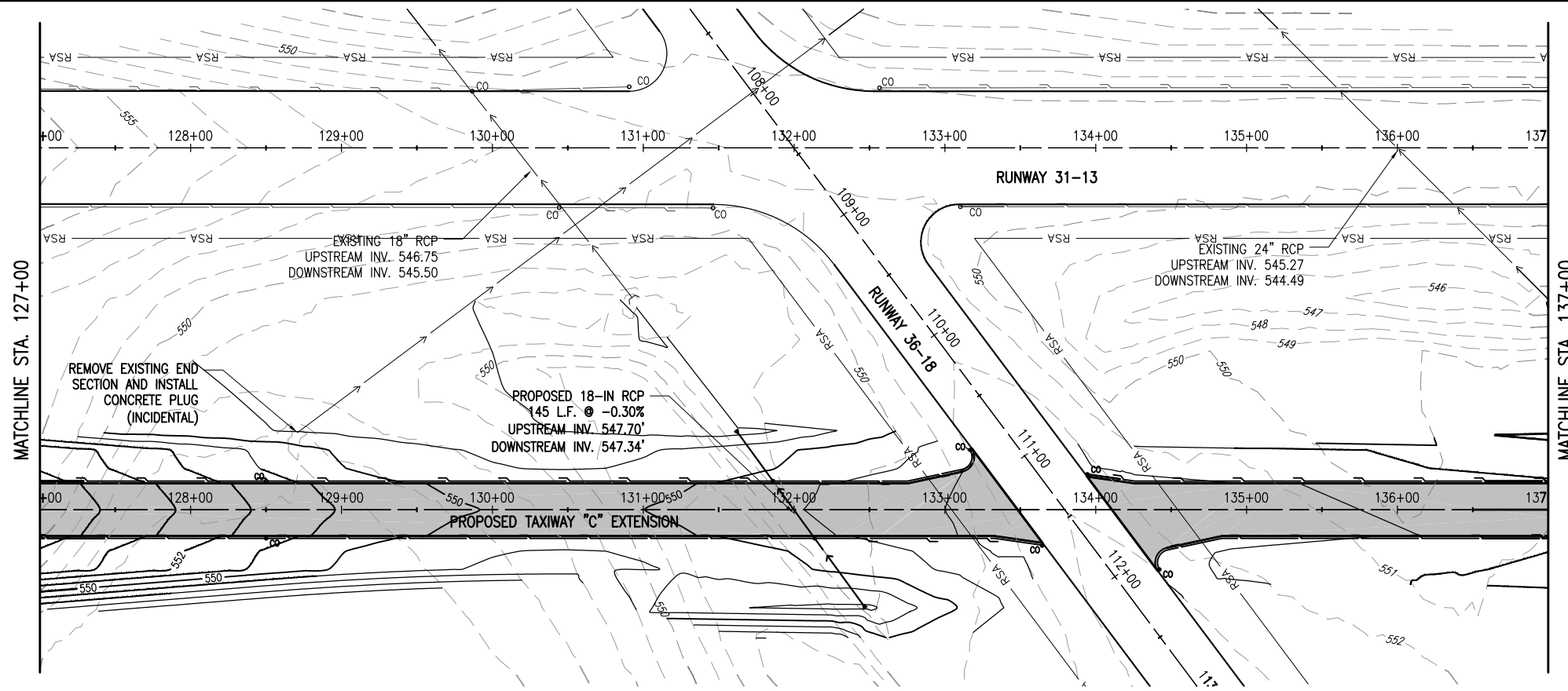

REVISION	DATE

MARSHALL COUNTY AIRPORT
 LACON, ILLINOIS
 IL PROJ.: C75-4218 BLOCK GRANT: 3-17-0059-B14

Hanson Project No.	09A0031
Filename	C-701-Plan-Profile.dwg
Scale	1" = 50'H, 1" = 5'V
Date	01/11/13
LAYOUT	BAK 08/07/12
DRAWN	BAK 08/07/12
REVIEWED	BSS 01/11/13



CONSTRUCT A 2,065' X 35'
 PARTIAL PARALLEL TAXIWAY
 TO RUNWAY 13/31
 PLAN AND PROFILE - STA.
 127+00 TO STA. 137+00

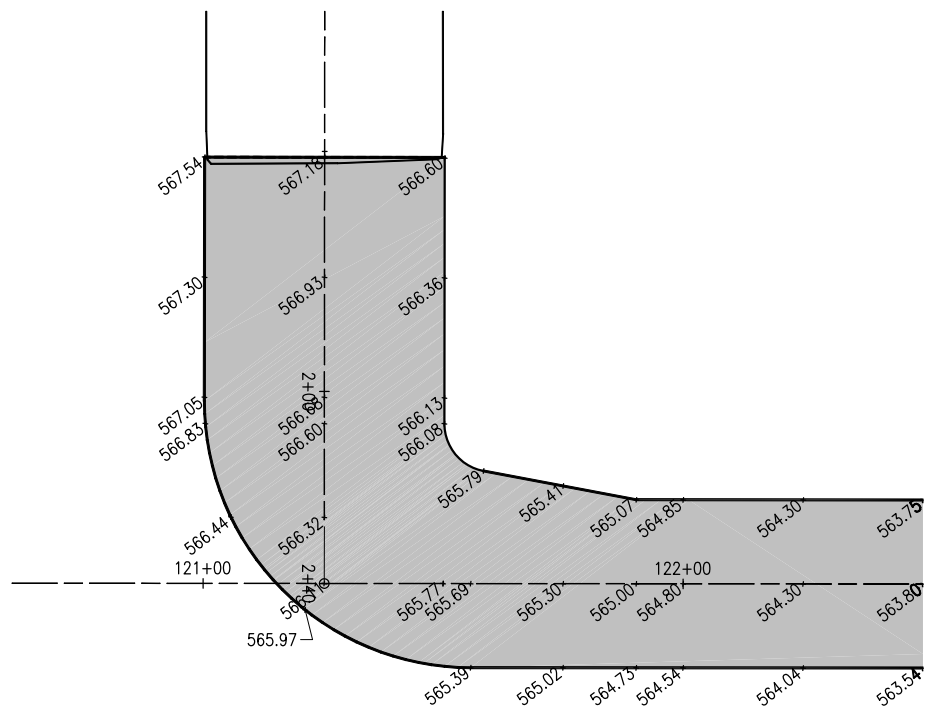

TAXIWAY "C" EXTENSION & TAXIWAY "C-3"
INTERSECTION DETAIL

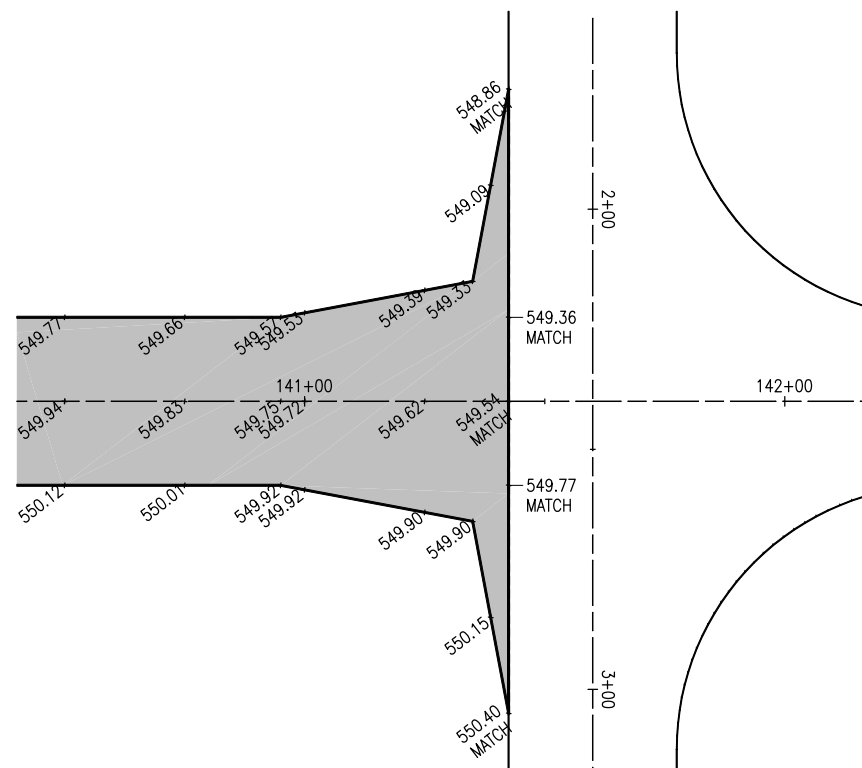

TAXIWAY "C" EXTENSION & TAXIWAY "C-2"
INTERSECTION DETAIL

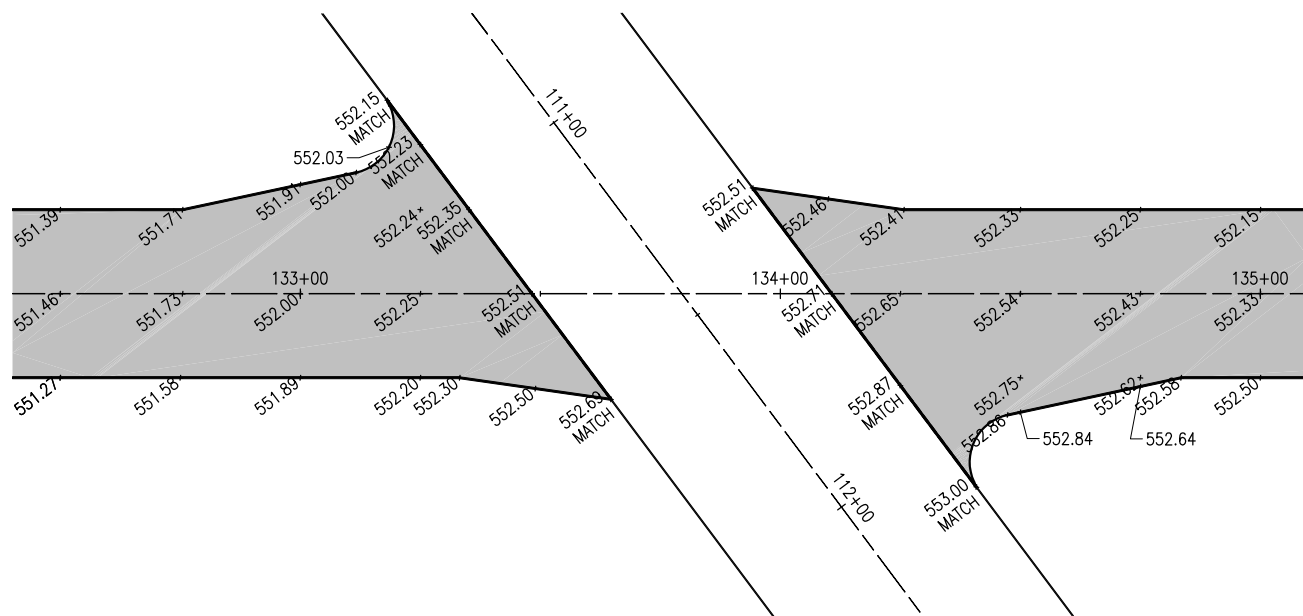

TAXIWAY "C" EXTENSION & RUNWAY "36-18"
INTERSECTION DETAIL

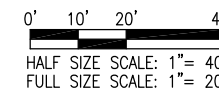
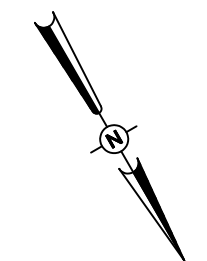

REVISION	DATE

MARSHALL COUNTY AIRPORT
LACON, ILLINOIS

IL PROJ.: C75-4218 BLOCK GRANT: 3-17-0059-B14

Hanson Project No.	09A0031
Filename	C-191-STK.dwg
Scale	1" = 20'
Date	01/11/13
LAYOUT	BAK 08/07/12
DRAWN	BAK 08/07/12
REVIEWED	BSS 01/11/13

© Copyright Hanson Professional Services Inc. 2013
Hanson Professional Services Inc.
1525 South Rock Street
Springfield, Illinois 62703-2886

CONSTRUCT A 2,065' X 35'
PARTIAL PARALLEL TAXIWAY
TO RUNWAY 13/31

SPOT ELEVATION PLAN

JAN 11, 2013 1:16 PM HARR01115
pw:\s\spi-svr306\hanson\dom\hanson_projects\Documents\09\jobs\09A0031\09A0031D\CAD\Airport\Sheet\C-191-STK

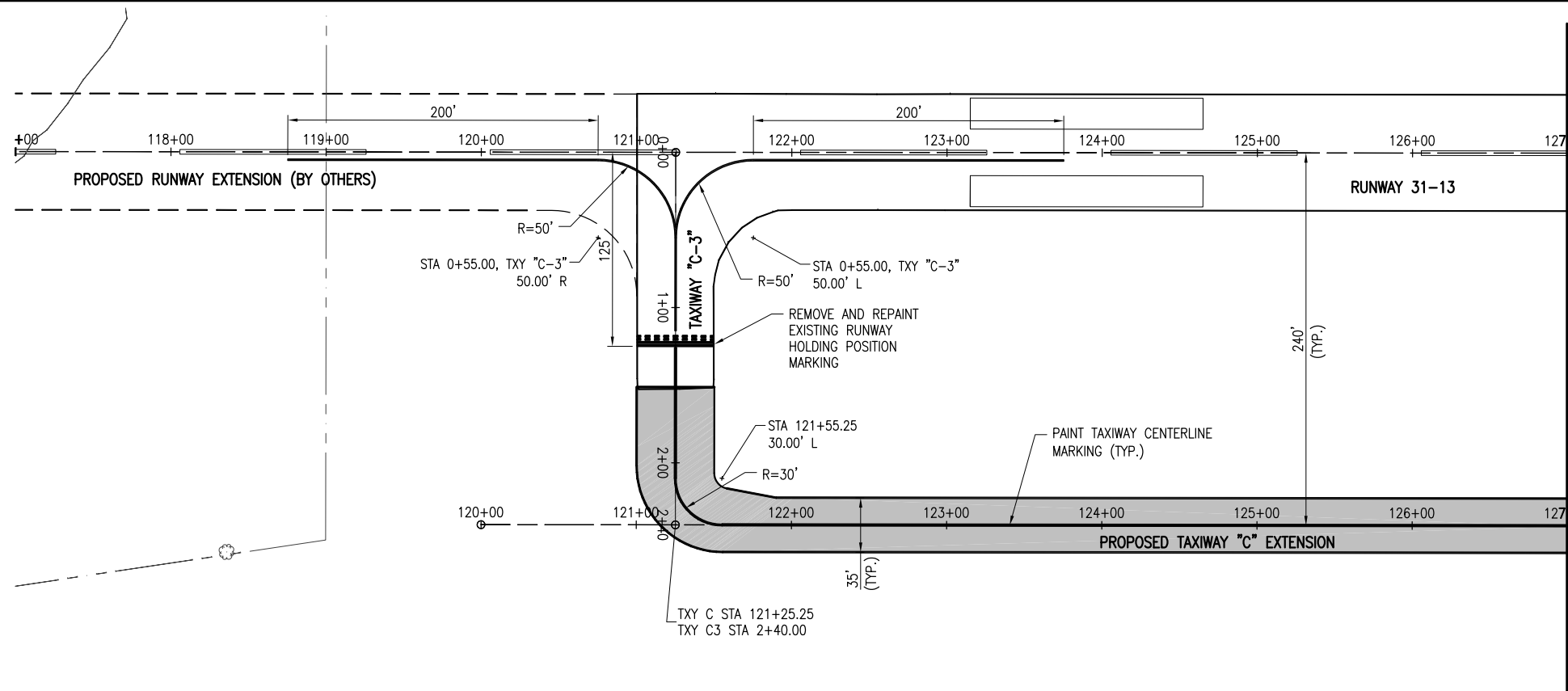

PAVEMENT MARKING NOTES

1. TYPE B GLASS BEADS SHALL BE REQUIRED FOR ALL YELLOW PERMANENT PAINT MARKINGS. GLASS BEADS ARE NOT REQUIRED FOR TEMPORARY MARKINGS OR BLACK PAINT. REFER TO SPECIFICATION ITEM 620 FOR ADDITIONAL INFORMATION.
2. PAINT SHALL MEET REQUIREMENTS OF TECHNICAL SPECIFICATION ITEM 620, WATERBORNE PAINT.
3. ALL EXISTING MARKINGS NOTED FOR REMOVAL SHALL BE COMPLETED USING HIGH PRESSURE WATER BLASTING OR METHOD APPROVED BY THE ENGINEER. PAINT REMOVAL BY GRINDING OR OTHER METHODS WHICH DAMAGE THE PAVEMENT SURFACES SHALL NOT BE USED. THE MARKINGS SHALL NOT BE PAINTED OVER WITH BLACK PAINT.
4. IMMEDIATELY PRIOR TO THE APPLICATION OF PAINT, ALL SURFACES SHALL BE DRY AND FREE FROM DIRT, GREASE, OIL, LAITANCE, OR OTHER FOREIGN MATERIAL WHICH WOULD REDUCE THE BOND BETWEEN THE PAINT AND THE PAVEMENT. THIS SHALL INCLUDE PAINTED AREAS ON THE EXISTING PAVEMENTS. REFER TO SPECIFICATION ITEM 620-3.3 FOR ADDITIONAL INFORMATION.
5. EXISTING PAVEMENT MARKINGS OUTSIDE THE LIMITS OF THE MARKINGS SHOWN ON THESE PLANS WHICH ARE REMOVED OR WORN DUE TO CONSTRUCTION ACTIVITY SHALL BE REPAINTED. NO ADDITIONAL COMPENSATION SHALL BE MADE FOR THIS WORK.

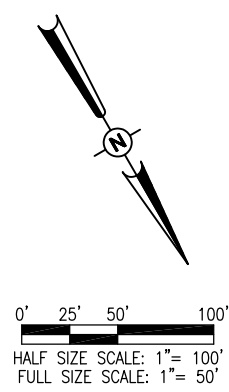
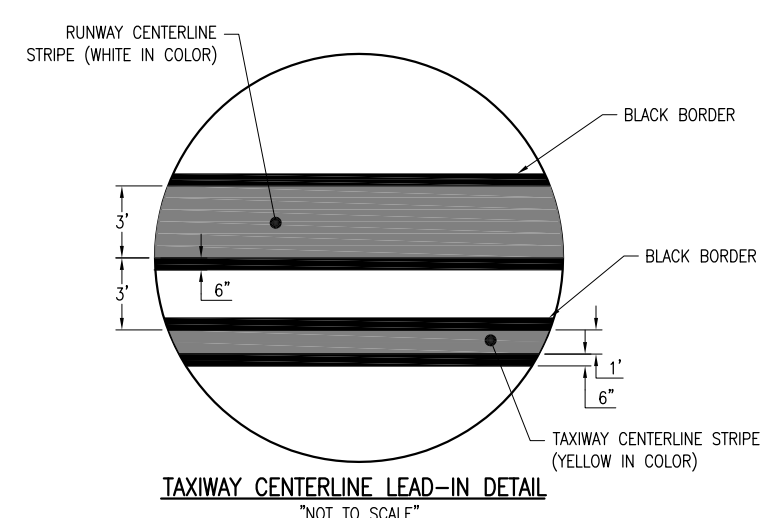
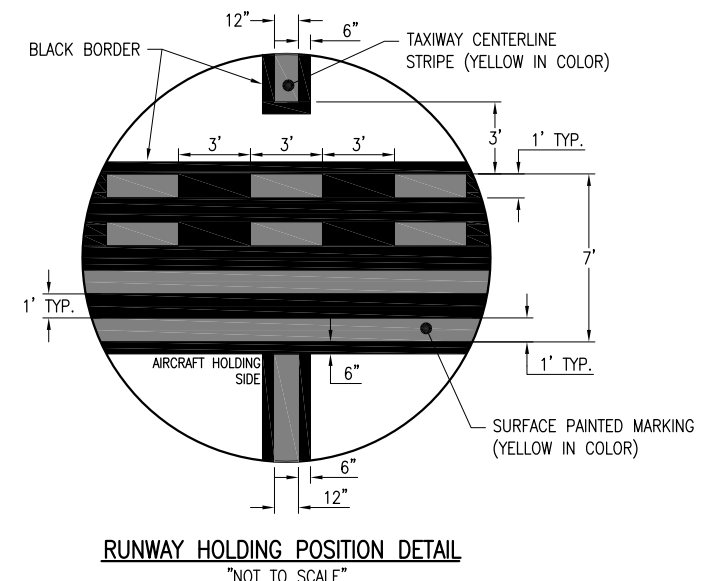
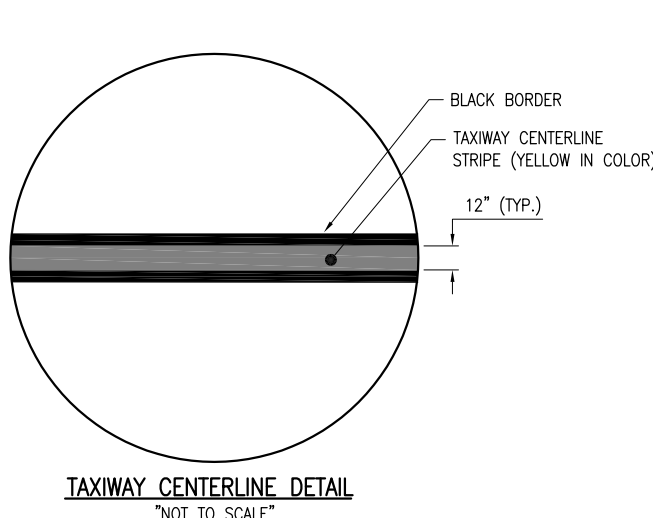

REVISION	
DATE	
MARSHALL COUNTY AIRPORT LACON, ILLINOIS	
BLOCK GRANT: 3-17-0059-B14	
IL PROJ.: C75-4218	

Hanson Project No.	09A0031
Filename	C-151-MRK.dwg
Scale	1" = 50'
Date	01/11/13
LAYOUT	BAK 08/07/12
DRAWN	BAK 08/07/12
REVIEWED	BSS 01/11/13

HANSON
 Copyright Hanson Professional Services Inc. 2013
 Hanson Professional Services Inc.
 1525 South Main Street
 Springfield, Illinois 62703-2886

CONSTRUCT A 2,065' X 35'
 PARTIAL PARALLEL TAXIWAY
 TO RUNWAY 13/31
 PROPOSED MARKING PLAN
 STA. 117+00 TO STA. 127+00

JAN 11, 2013 1:16 PM HARR01115
 pw:\s\spi-sv\306.hanson.com\Hanson Projects\Documents\09A0031\09A0031D\CAD\Airport\Sheet\C-151-MRK

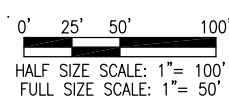
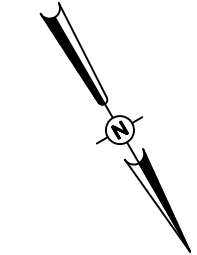
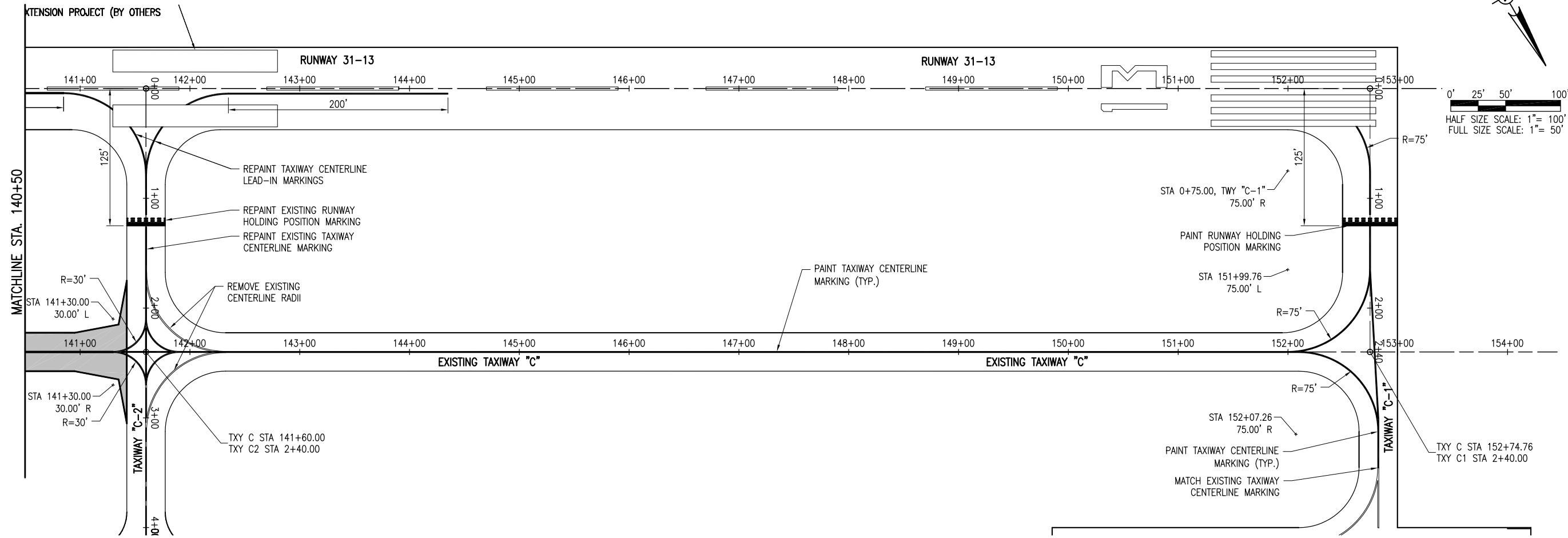
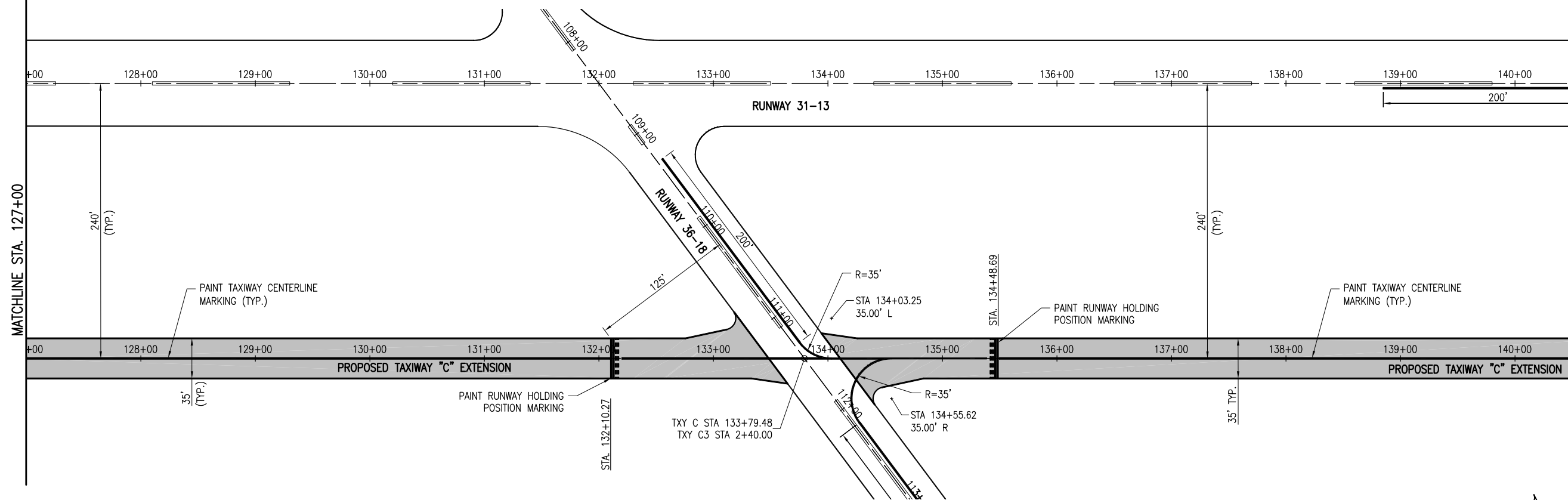

JAN 11, 2013 1:16 PM HARR01115
 pw:\s\svr306\hanson\Projects\Documents\09\jobs\09A0031\09A0031D\CAD\Airport\Sheet\C-151-MRK

REVISION	DATE

MARSHALL COUNTY AIRPORT
LACON, ILLINOIS

IL PROJ.: C75-4218 BLOCK GRANT: 3-17-0059-B14

Hanson Project No.	09A0031
Filename	C-151-MRK.dwg
Scale	1" = 50'
Date	01/11/13
LAYOUT	BAK 08/07/12
DRAWN	BAK 08/07/12
REVIEWED	BSS 01/11/13



CONSTRUCT A 2,065' X 35'
 PARTIAL PARALLEL TAXIWAY
 TO RUNWAY 13/31
 PROPOSED MARKING PLAN
 STA. 127+00 TO STA. 153+00

STORM WATER POLLUTION PREVENTION NOTES

1. THE CONTRACTOR SHALL IMPLEMENT ALL PROVISIONS OF THE CONTRACT DOCUMENTS TO ASSURE THAT STORM WATER POLLUTION PREVENTION ITEMS ARE CONSTRUCTED AND MAINTAINED IN A TIMELY MANNER. SEDIMENTATION MUST NOT BE TRANSPORTED OFF THE CONSTRUCTION SITE. PERMANENT DRAINAGE FEATURES AND VEGETATIVE MEASURES SHALL BE PROVIDED AS SOON AS POSSIBLE.
2. THE CONTRACTOR SHALL BE REQUIRED TO IMPLEMENT AND MAINTAIN STORM WATER POLLUTION PREVENTION PRACTICES AND MEASURES PRIOR TO THE STRIPPING OF EXISTING VEGETATION WHERE EVER POSSIBLE AND AS SOON AS CONSTRUCTION PERMITS IN OTHER AREAS. POLLUTION CONTROL MEASURES SHALL BE IN ACCORDANCE WITH THE CONTRACT DOCUMENTS, INCLUDING THESE CONSTRUCTION PLANS, AND WITH STANDARDS AND SPECIFICATIONS FOR SOIL EROSION AND SEDIMENT CONTROL, ILLINOIS ENVIRONMENTAL PROTECTION AGENCY, CURRENT ISSUE. THE CONTRACTOR SHALL ADJUST HIS OPERATIONS AND IMPLEMENT POLLUTION CONTROL MEASURES SO THAT NO RUNOFF FROM STRIPPED AREAS WILL LEAVE THE CONSTRUCTION SITE OTHER THAN THROUGH SEDIMENT TRAPS OR OTHER SUITABLE CONTROL MEASURES.
3. POLLUTION CONTROL ITEMS SHALL BE PROVIDED AS NOTED ON THE STORM WATER POLLUTION PREVENTION PLAN AND IN THE STORM WATER POLLUTION PREVENTION DETAILS AND AS DIRECTED BY THE ENGINEER. THE LIMITS OF SUCH MEASURES SHALL BE STAKED BY THE CONTRACTOR PRIOR TO THE COMMENCEMENT OF CONSTRUCTION. SUCH LIMITS MAY BE ADJUSTED BY THE ENGINEER TO ACCOUNT FOR ACTUAL SITE CONDITIONS EXPERIENCED DURING CONSTRUCTION. ADDITIONAL COMPENSATION FOR MEASURES EXCEEDING THE PLAN QUANTITIES WILL BE PAID FOR AT THE CONTRACT UNIT PRICE FOR EACH ITEM.
4. THE CONTRACTOR IS TO MAINTAIN AND ADJUST, REPAIR OR REPLACE ALL POLLUTION PREVENTION MEASURES AS REQUIRED OR AS DIRECTED BY THE ENGINEER UNTIL PERMANENT VEGETATION HAS BEEN ESTABLISHED. MAINTENANCE OF POLLUTION CONTROL MEASURES IS TO BE PROVIDED AT NO ADDITIONAL COST TO THE CONTRACT.

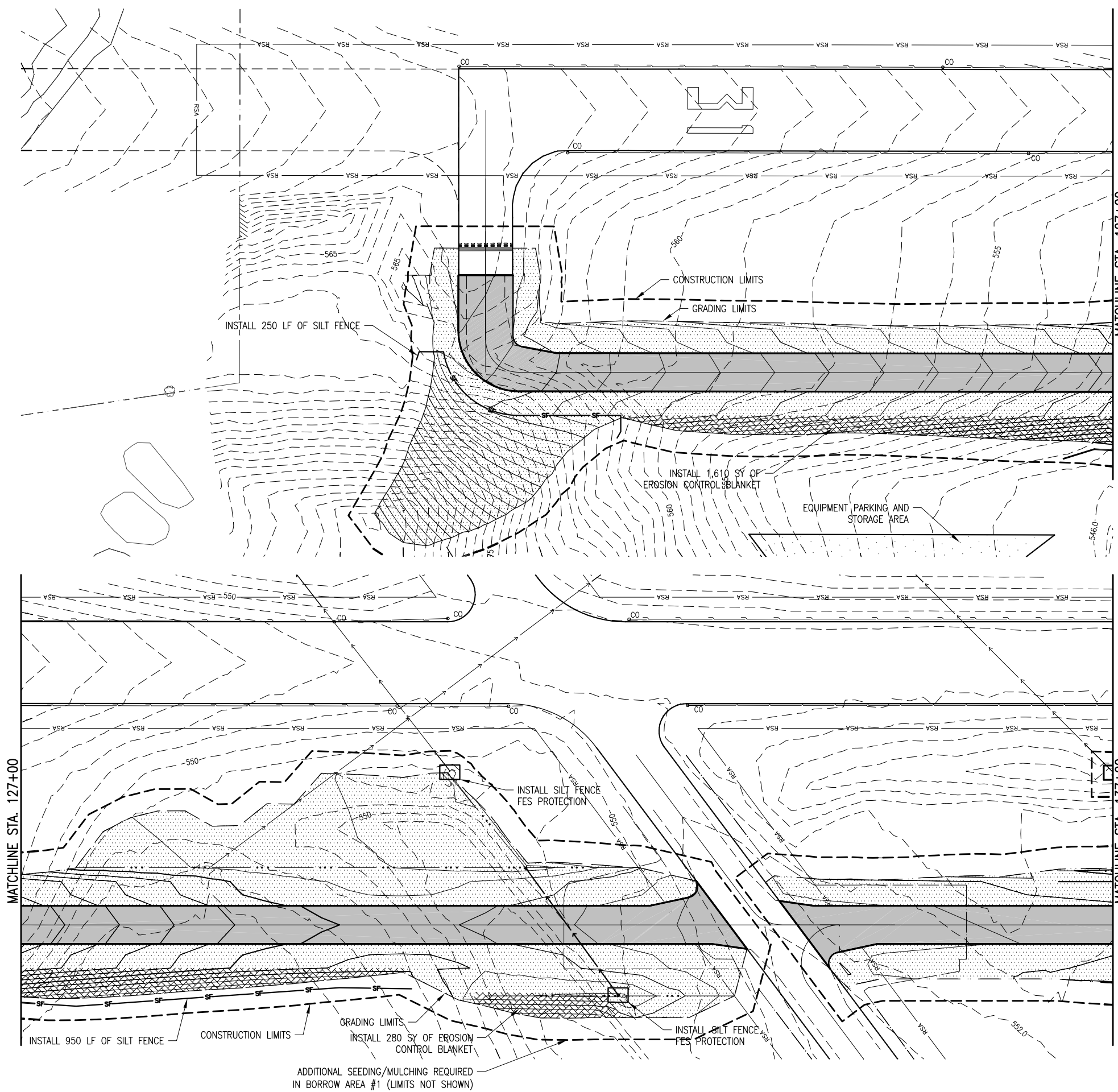

LEGEND

- PROPOSED PAVEMENT
- CONSTRUCTION LIMITS
- PROPOSED SEEDING/MULCHING
- PROPOSED EROSION CONTROL BLANKET
- PROPOSED SILT FENCE

0' 25' 50' 100'

HALF SIZE SCALE: 1" = 100'

FULL SIZE SCALE: 1" = 50'

REVISION	DATE

MARSHALL COUNTY AIRPORT
LACON, ILLINOIS

IL PROJ.: C75-4218 BLOCK GRANT: 3-17-0059-B14

Hanson Project No.	09A0031
Filename	C-181-SWP.dwg
Scale	1" = 50'
Date	01/11/13
LAYOUT	BAK 08/07/12
DRAWN	BAK 08/07/12
REVIEWED	BSS 01/11/13

© Copyright Hanson Professional Services Inc. 2013
Hanson Professional Services Inc.
1525 South Main Street
Springfield, Illinois 62703-2886

CONSTRUCT A 2,065' X 35'
PARTIAL PARALLEL TAXIWAY
TO RUNWAY 13/31

PROPOSED STORMWATER
POLLUTION PREVENTION PLAN

JAN 11, 2013 1:16 PM HARR01115
pw:\spr-sv306\hanson\dom\hanson Projects\Documents\09\jobs\09A0031\09A0031D\CAD\Airport\Sheet\C-181-SWP

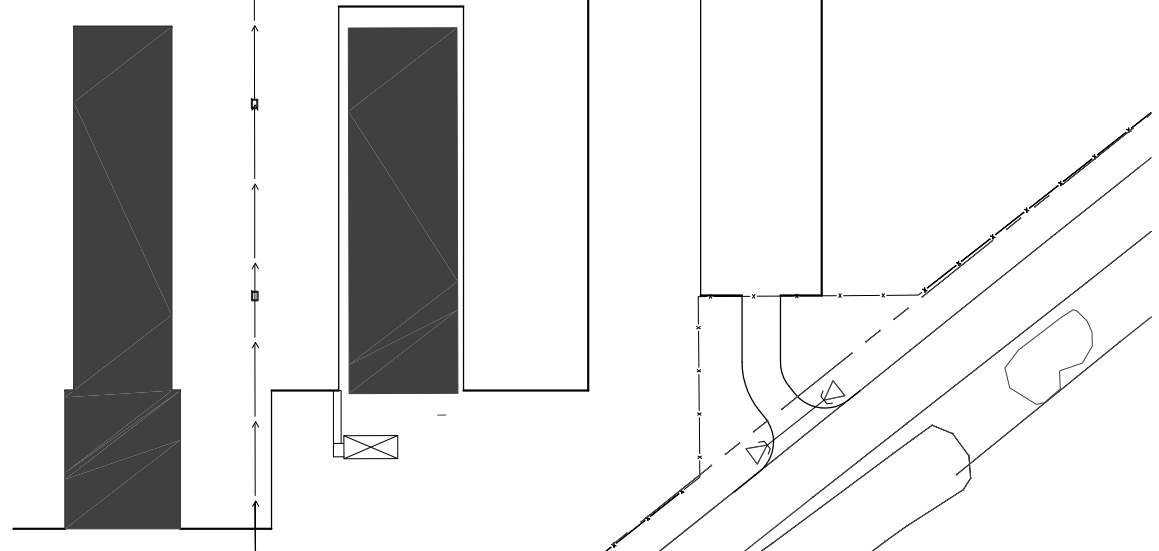
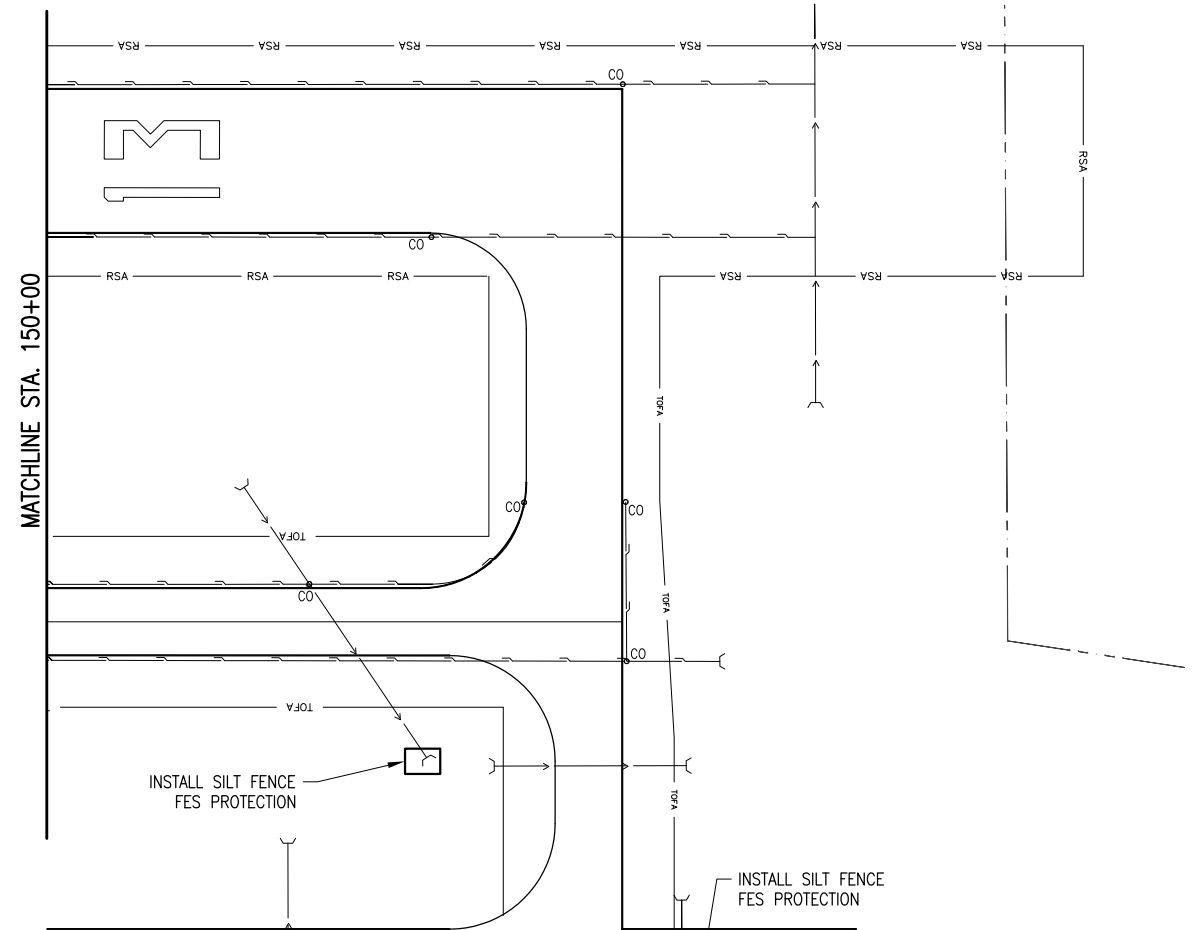
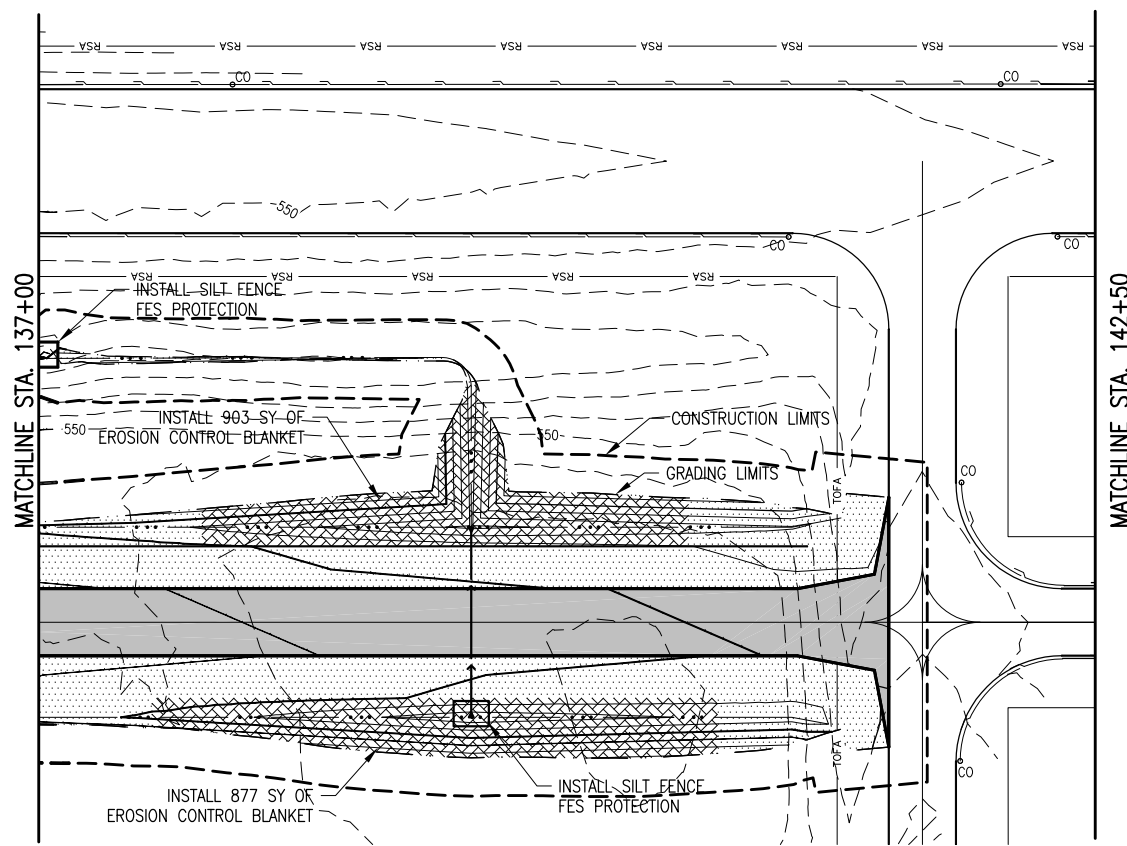

LEGEND

- PROPOSED PAVEMENT
- CONSTRUCTION LIMITS
- PROPOSED SEEDING/MULCHING
- PROPOSED EROSION CONTROL BLANKET
- PROPOSED SILT FENCE

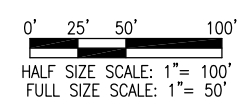
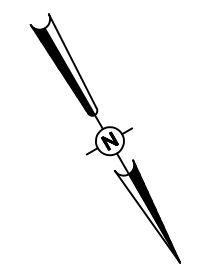

REVISION	DATE

MARSHALL COUNTY AIRPORT
LACON, ILLINOIS

IL PROJ.: C75-4218 BLOCK GRANT: 3-17-0059-B14

Hanson Project No.	09A0031
Filename	C-181-SWP.dwg
Scale	1" = 50'
Date	01/11/13
LAYOUT	BAK 08/07/12
DRAWN	BAK 08/07/12
REVIEWED	BSS 01/11/13

HANSON
Professional Services Inc.
1525 South Lincoln Street
Springfield, Illinois 62703-2886

CONSTRUCT A 2,065' X 35'
PARTIAL PARALLEL TAXIWAY
TO RUNWAY 13/31

PROPOSED STORMWATER
POLLUTION PREVENTION PLAN
(2)

JAN 11, 2013 1:16 PM HARR01115
pw:\s\spi-svr306\hanson.com\Projects\Documents\09\Jobs\09A0031\09A0031D\CAD\Airport\Sheet\C-181-SWP

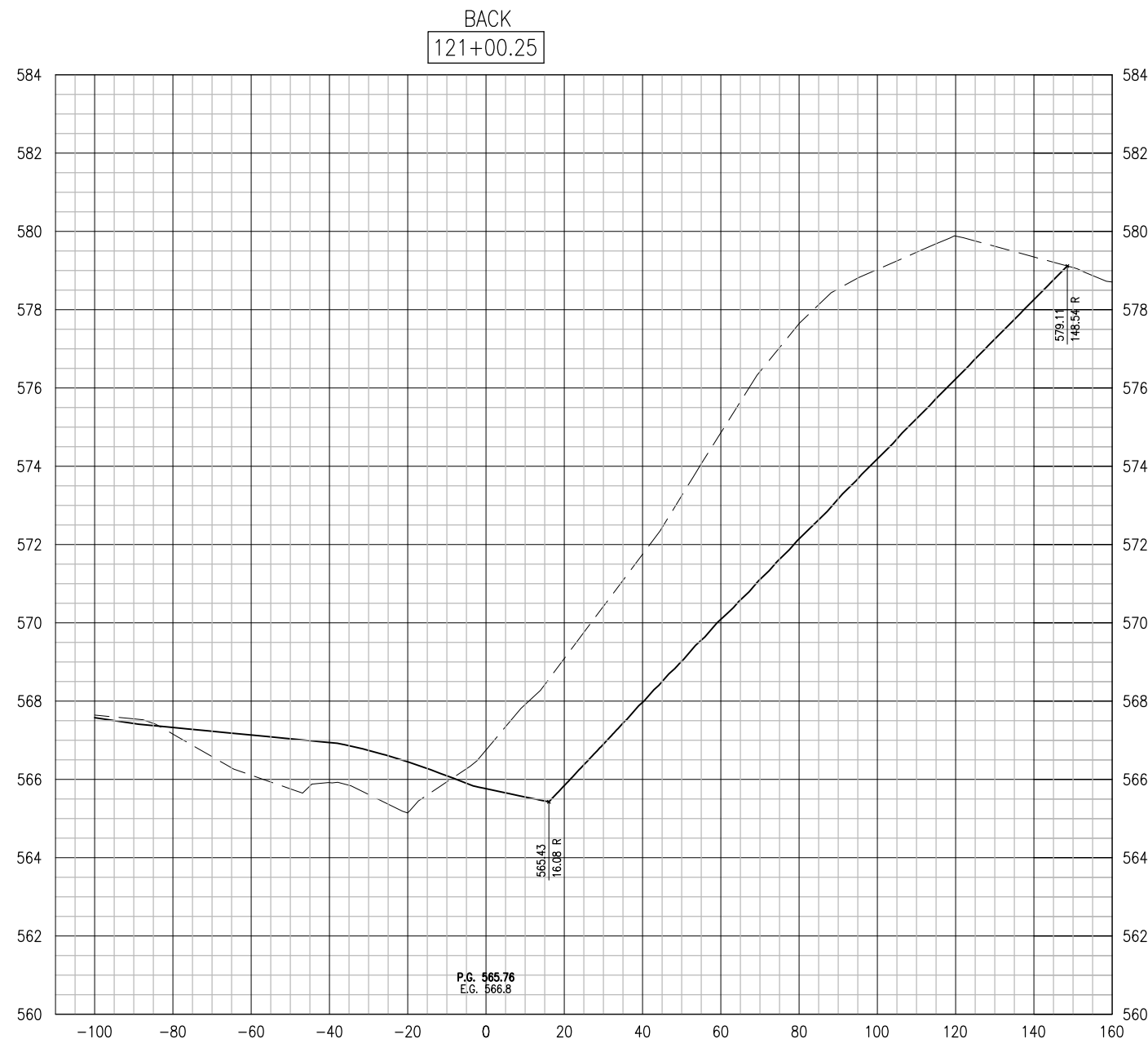
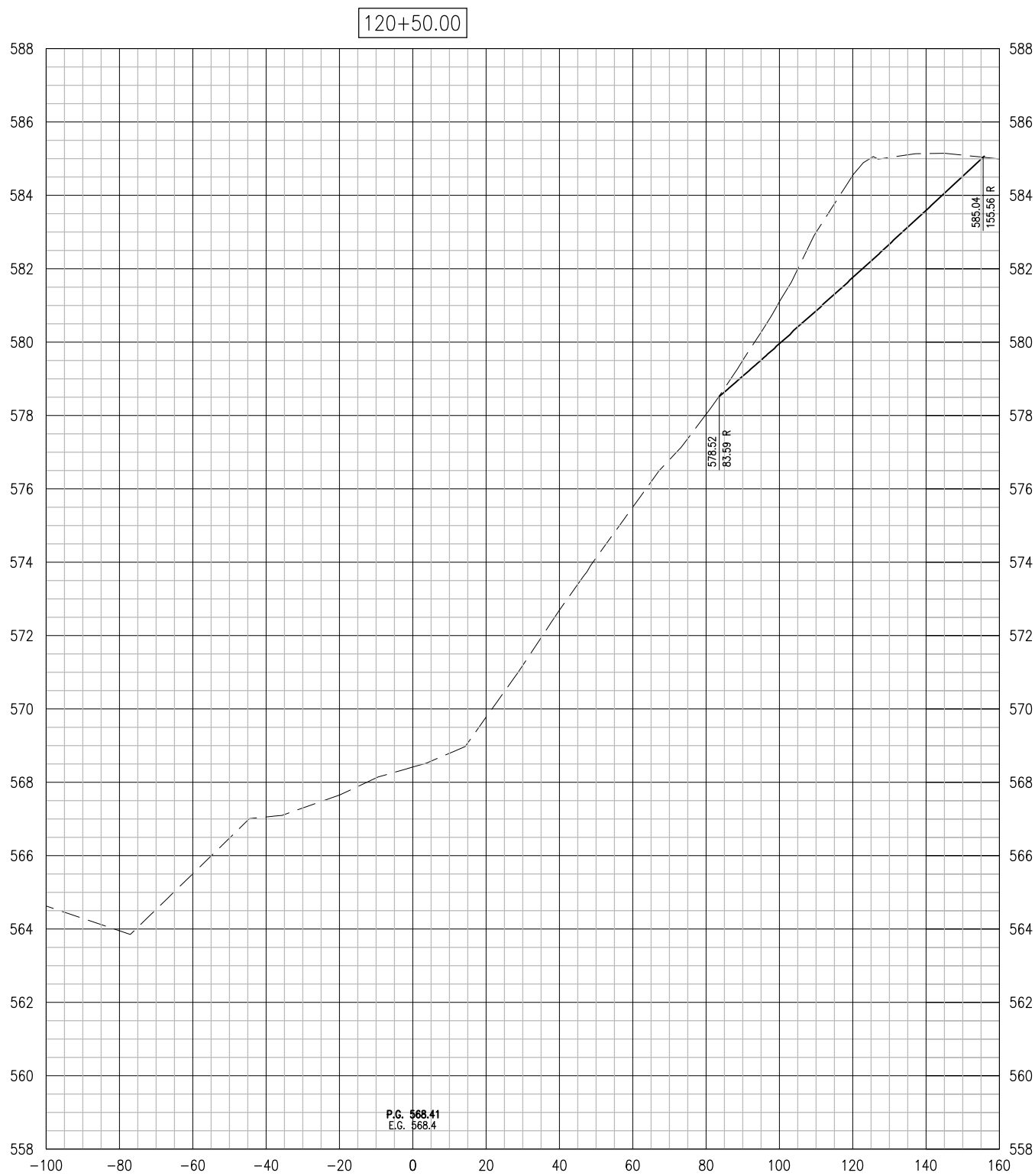

JAN 11, 2013 1:17 PM HARR01115
pw:\sps-svr306\hanson.dom\hanson_projects\Documents\09\jobs\09A0031\09A0031D\CAD\Airport\Sheet\C-301-XS

REVISION	DATE

MARSHALL COUNTY AIRPORT
LACON, ILLINOIS

IL PROJ.: C75-4218 BLOCK GRANT: 3-17-0059-B14

Hanson Project No.	09A0031
Filename	C-301-XS.dwg
Scale	1" = 20'H 1" = 2'V
Date	01/11/13
LAYOUT	MLH 12/06/12
DRAWN	MLH 12/06/12
REVIEWED	BSS 01/11/13



CONSTRUCT A 2,065' X 35'
PARTIAL PARALLEL TAXIWAY
TO RUNWAY 13/31

CROSS SECTIONS STA. 120+50
TO STA. 121+00.25

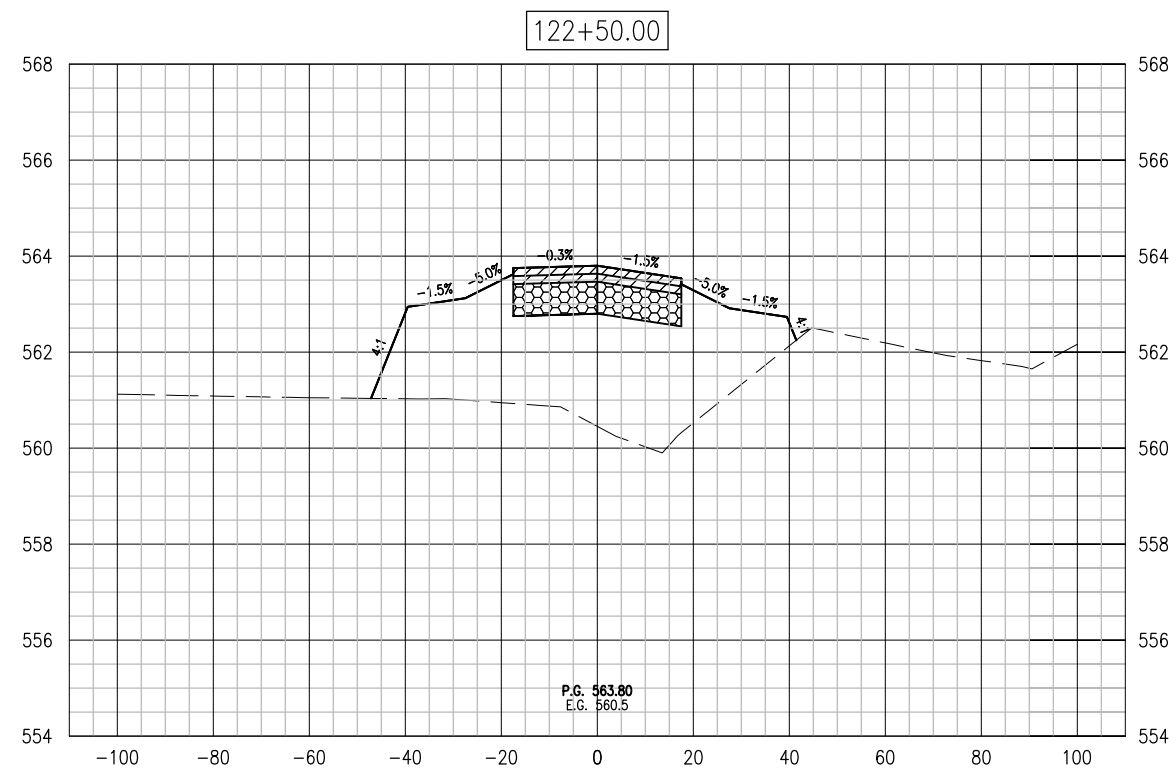
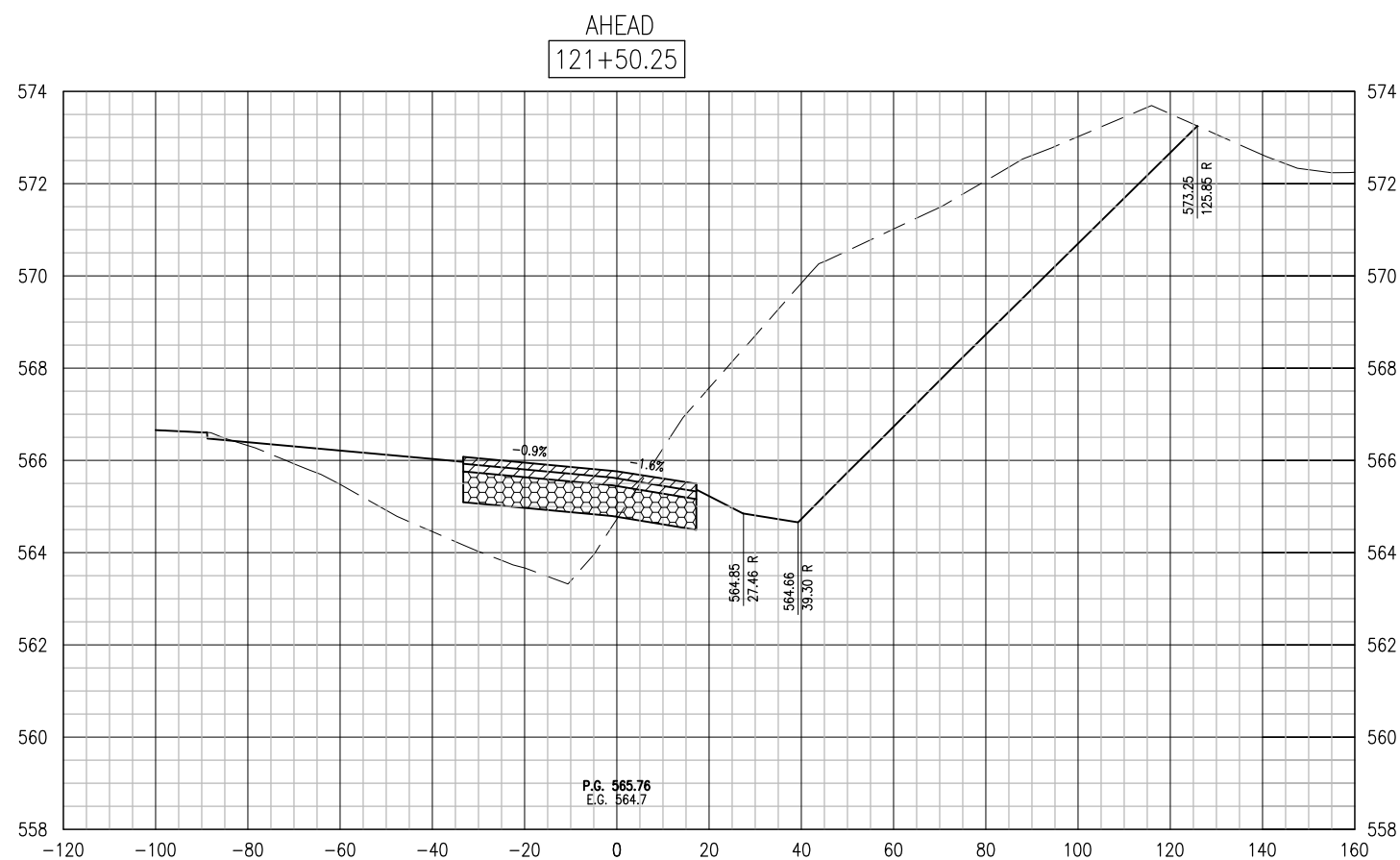
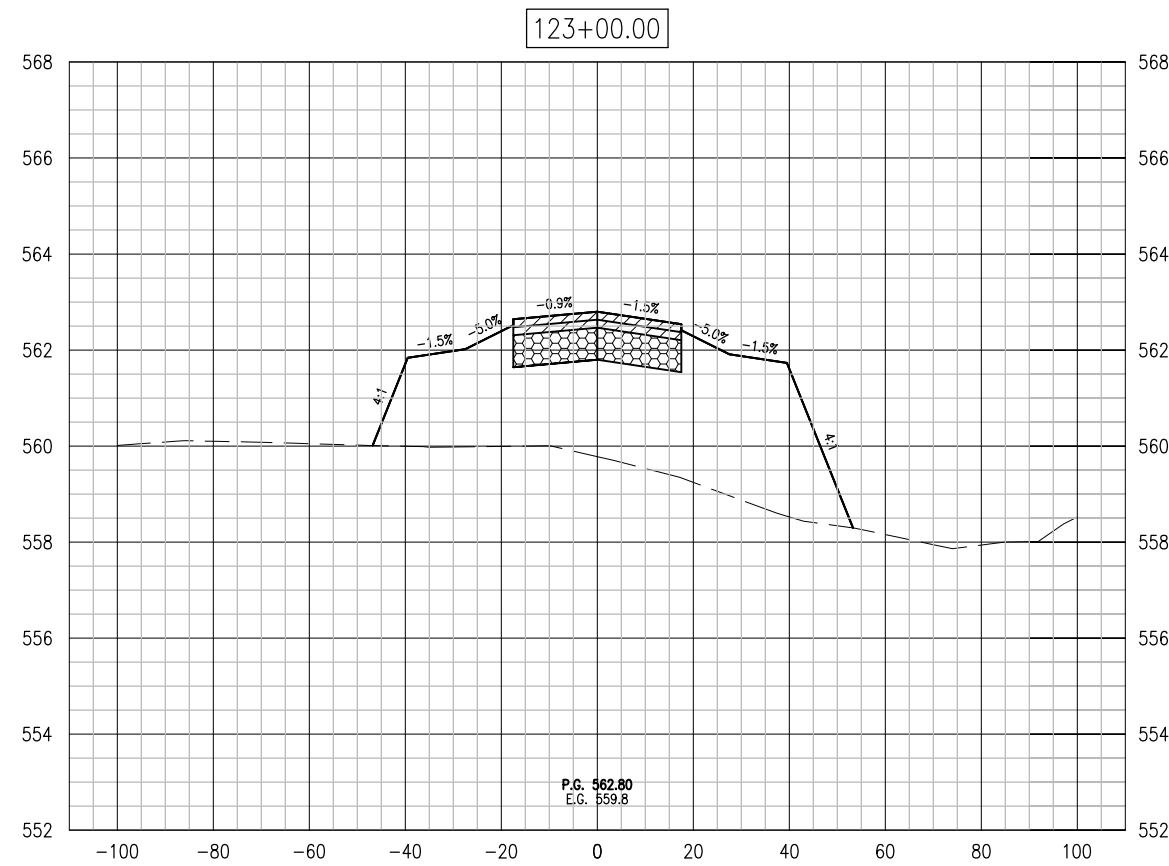

REVISION	DATE

MARSHALL COUNTY AIRPORT
LACON, ILLINOIS

IL PROJ.: C75-4218 BLOCK GRANT: 3-17-0059-B14

Hanson Project No.	09A0031
Filename	C-301-XS.dwg
Scale	1" = 20'H, 1" = 2'V
Date	01/11/13
LAYOUT	MLH 12/06/12
DRAWN	MLH 12/06/12
REVIEWED	BSS 01/11/13



© Copyright Hanson Professional Services Inc. 2013
Hanson Professional Services Inc.
1525 South Illinois Street
Springfield, Illinois 62703-2886

CONSTRUCT A 2,065' X 35'
PARTIAL PARALLEL TAXIWAY
TO RUNWAY 13/31

CROSS SECTIONS STA.
121+50.25 TO STA. 123+00

JAN 11, 2013 1:17 PM HARR01115
pw:\sps-svc\06.hanson.com\Hanson Projects\Documents\09.jobs\09A0031\09A0031D\CAD\Airport\Sheet\C-301-XS

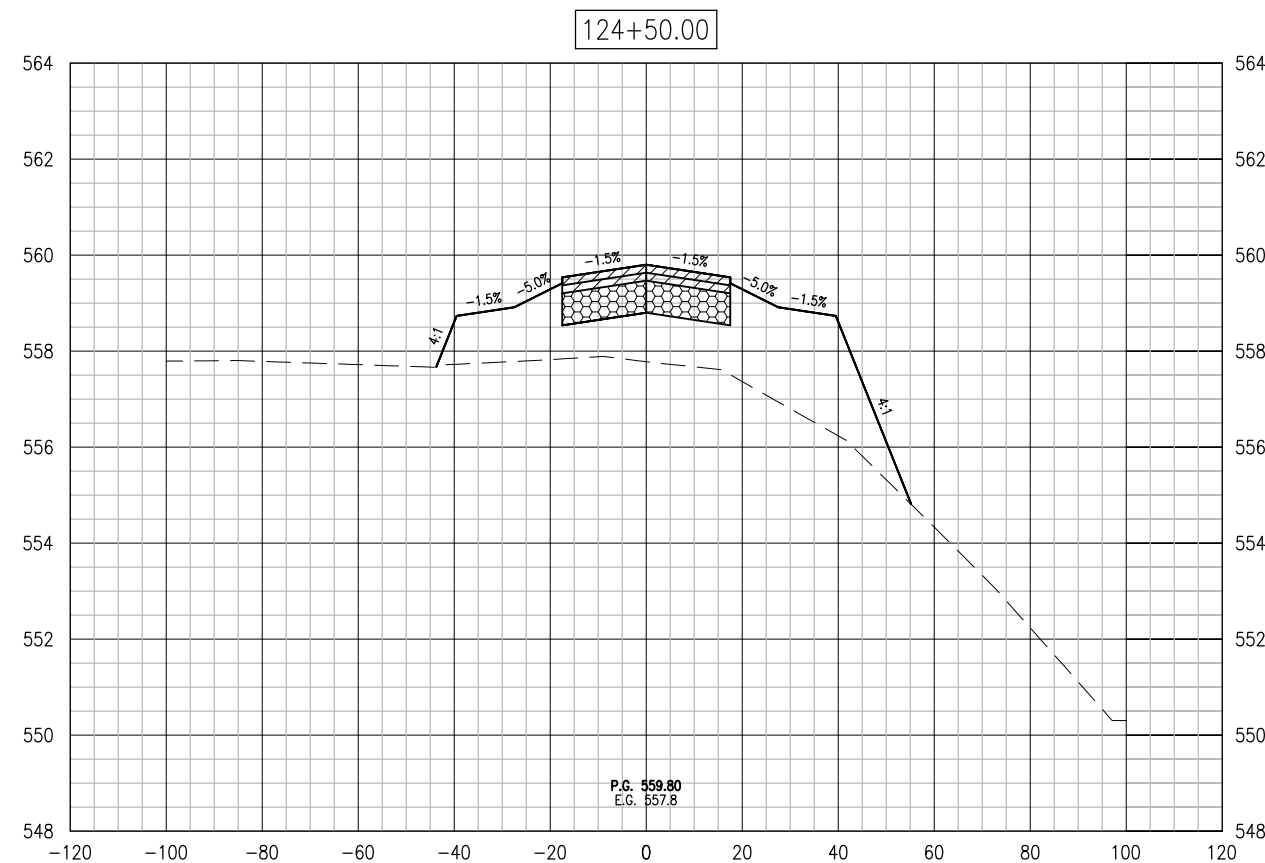
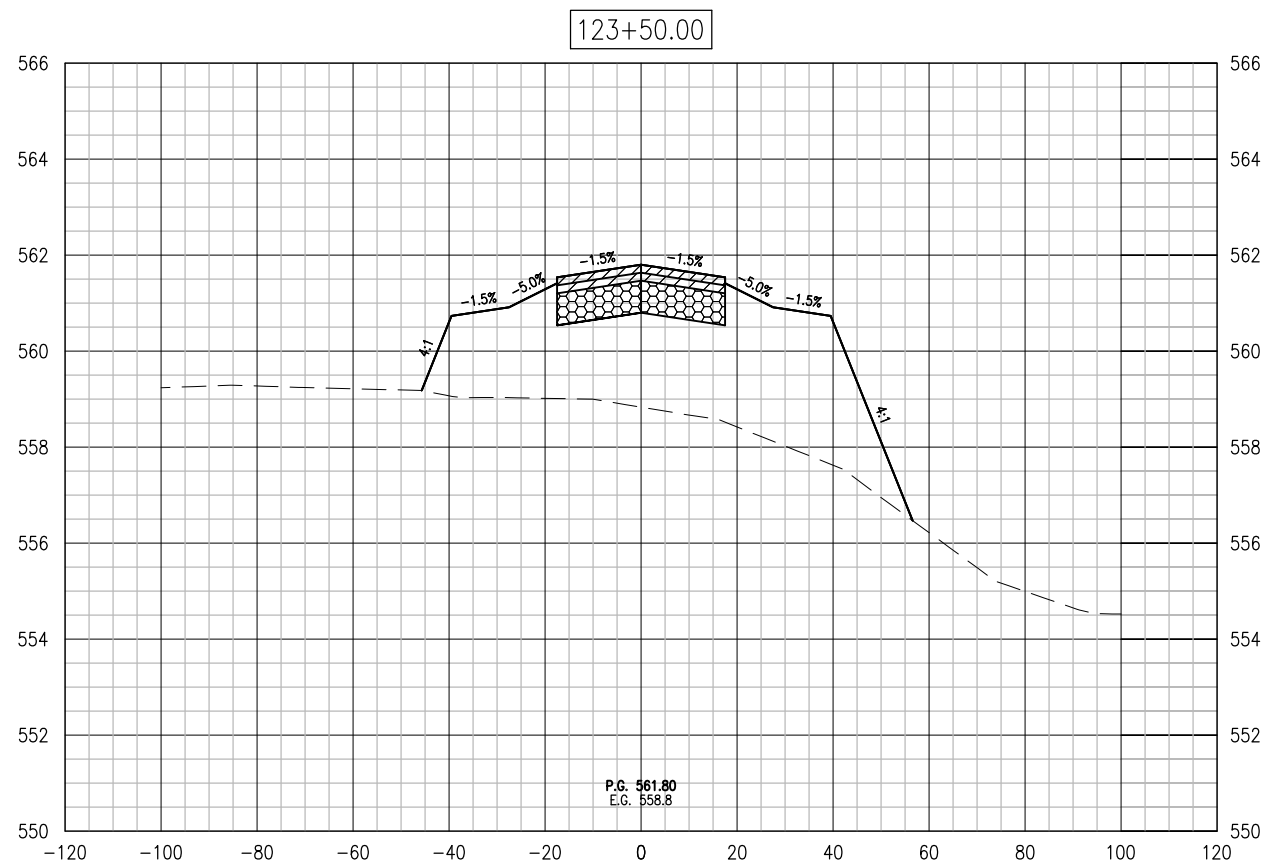
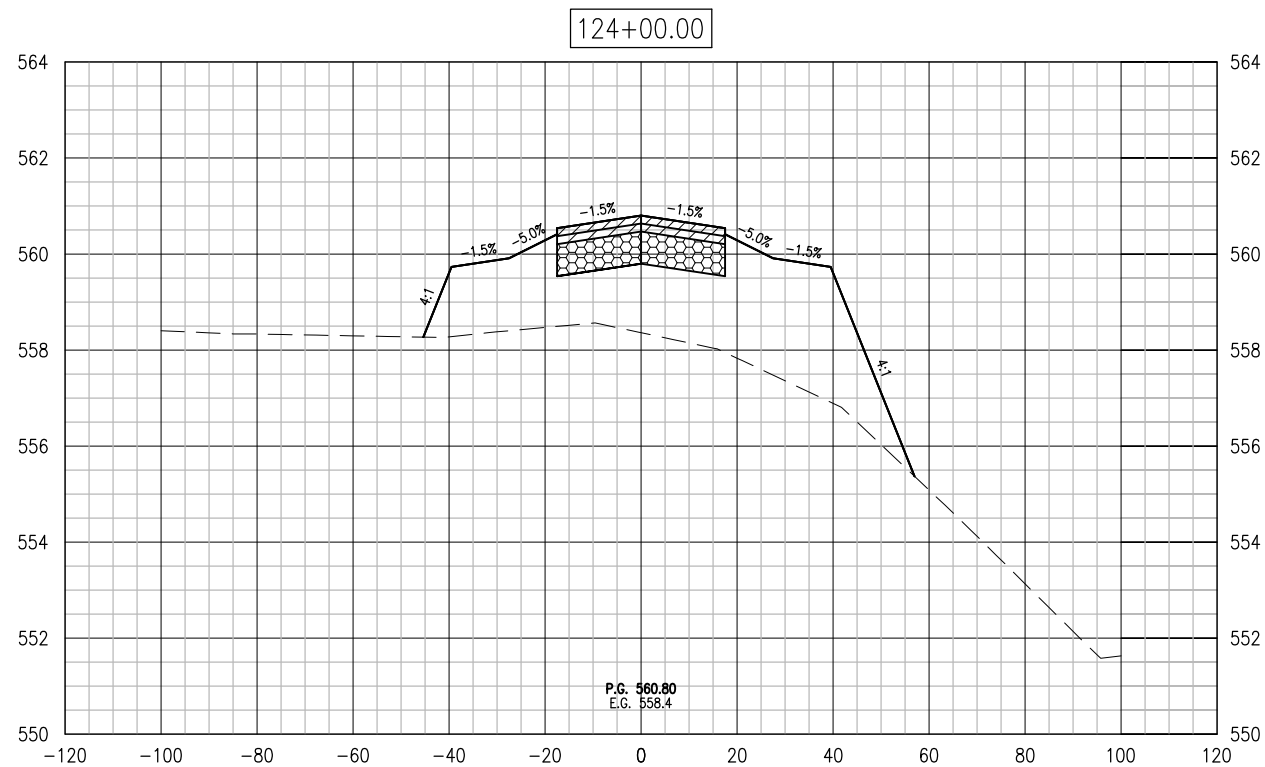

REVISION	DATE

MARSHALL COUNTY AIRPORT
LACON, ILLINOIS

IL PROJ.: C75-4218 BLOCK GRANT: 3-17-0059-B14

Hanson Project No.	09A0031
Filename	C-301-XS.dwg
Scale	1" = 20'H, 1" = 2'V
Date	01/11/13
LAYOUT	MLH 12/06/12
DRAWN	MLH 12/06/12
REVIEWED	BSS 01/11/13



© Copyright Hanson Professional Services Inc. 2013
Hanson Professional Services Inc.
1525 North Lincoln Street
Springfield, Illinois 62703-2886

CONSTRUCT A 2,065' X 35'
PARTIAL PARALLEL TAXIWAY
TO RUNWAY 13/31

CROSS SECTIONS STA. 123+50
TO STA. 124+50

JAN 11, 2013 1:17 PM HARR01115
pw:\s\p\svr306\hanson\dom\hanson_projects\Documents\09\jobs\09A0031\09A0031D\CAD\Airport\Sheet\C-301-XS

JAN 11, 2013 1:17 PM HARR01115
 pw:\s\svr306\hanson.dom\hanson_projects\Documents\09\Jobs\09A0031\09A0031D\CAD\Airport\Sheet\C-301-XS



REVISION	DATE

MARSHALL COUNTY AIRPORT
 LACON, ILLINOIS

IL PROJ.: C75-4218 BLOCK GRANT: 3-17-0059-B14

Hanson Project No.	09A0031
Filename	C-301-XS.dwg
Scale	1" = 20'H 1" = 2'V
Date	01/11/13
LAYOUT	MLH 12/06/12
DRAWN	MLH 12/06/12
REVIEWED	BSS 01/11/13



CONSTRUCT A 2,065' X 35'
 PARTIAL PARALLEL TAXIWAY
 TO RUNWAY 13/31

CROSS SECTIONS STA. 125+00
 TO STA. 125+50

JAN 11, 2013 1:17 PM HARR01115
 pw:\sps-svc06\hanson.dom\hanson_projects\Documents\09\jobs\09A0031\09A0031D\CAD\Airport\Sheet\C-301-XS

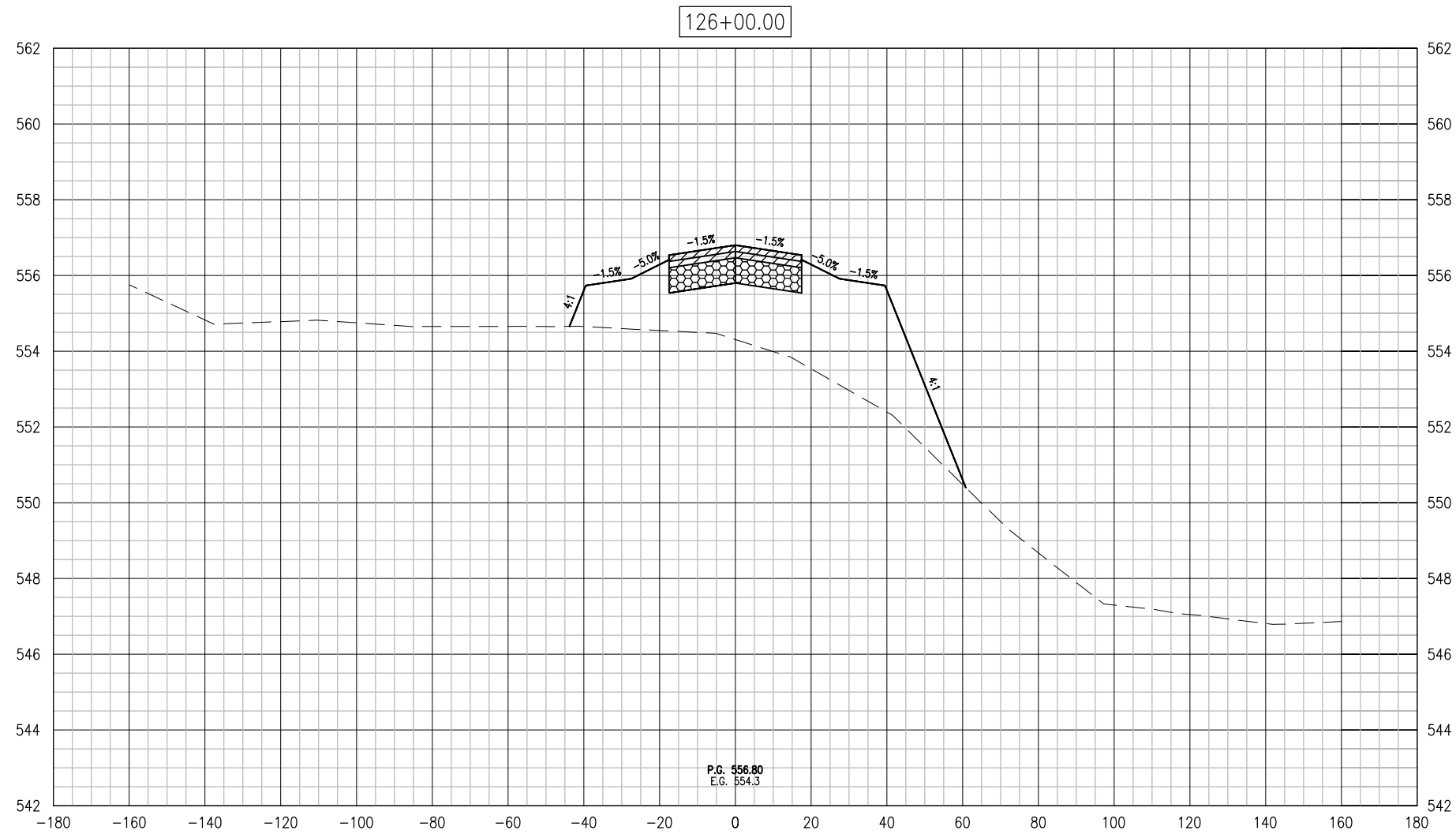

126+00.00

P.G. 556.80
 E.G. 554.3

DATE	REVISION

MARSHALL COUNTY AIRPORT
 LACON, ILLINOIS

IL PROJ.: C75-4218 BLOCK GRANT: 3-17-0059-B14

Hanson Project No. 09A0031	LAYOUT	MLH	12/06/12
Filename C-301-XS.dwg	DRAWN	MLH	12/06/12
Scale 1" = 20'H 1" = 2'V	REVIEWED	BSS	01/11/13
Date 01/11/13			



CONSTRUCT A 2,065' X 35'
 PARTIAL PARALLEL TAXIWAY
 TO RUNWAY 13/31

CROSS SECTIONS STA. 126+00

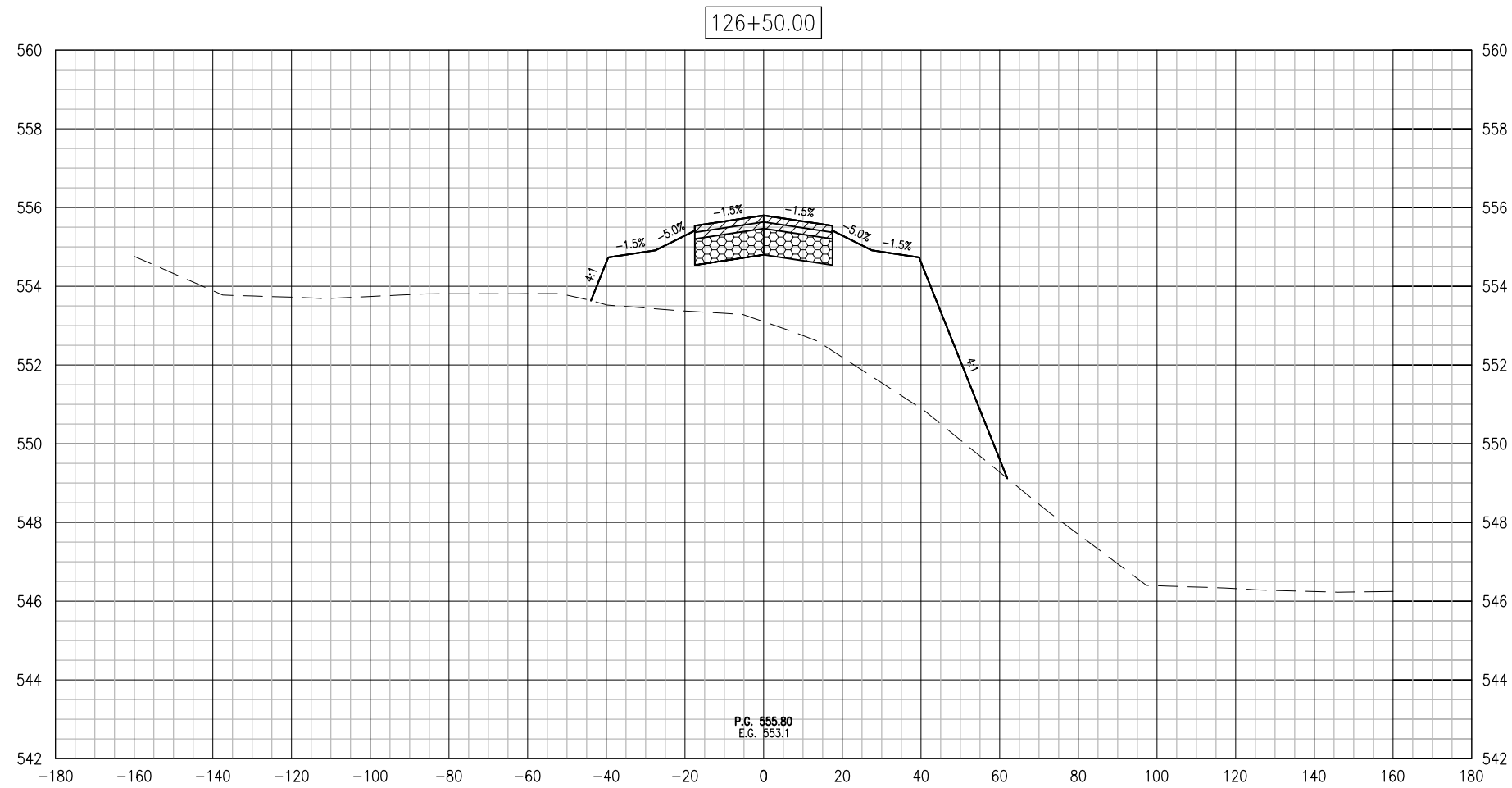

DATE	REVISION

MARSHALL COUNTY AIRPORT
 LACON, ILLINOIS

IL PROJ.: C75-4218 BLOCK GRANT: 3-17-0059-B14

Hanson Project No.	09A0031
Filename	C-301-XS.dwg
Scale	1" = 20'H 1" = 2'V
Date	01/11/13
LAYOUT	MLH 12/06/12
DRAWN	MLH 12/06/12
REVIEWED	BSS 01/11/13



CONSTRUCT A 2,065' X 35'
 PARTIAL PARALLEL TAXIWAY
 TO RUNWAY 13/31

CROSS SECTIONS STA. 126+50

JAN 11, 2013 1:17 PM HARR01115
 pw:\s\spi-svc\06.hanson.dom\hanson_projects\Documents\09.jobs\09A0031\09A0031D\CAD\Airport\Sheet\C-301-XS

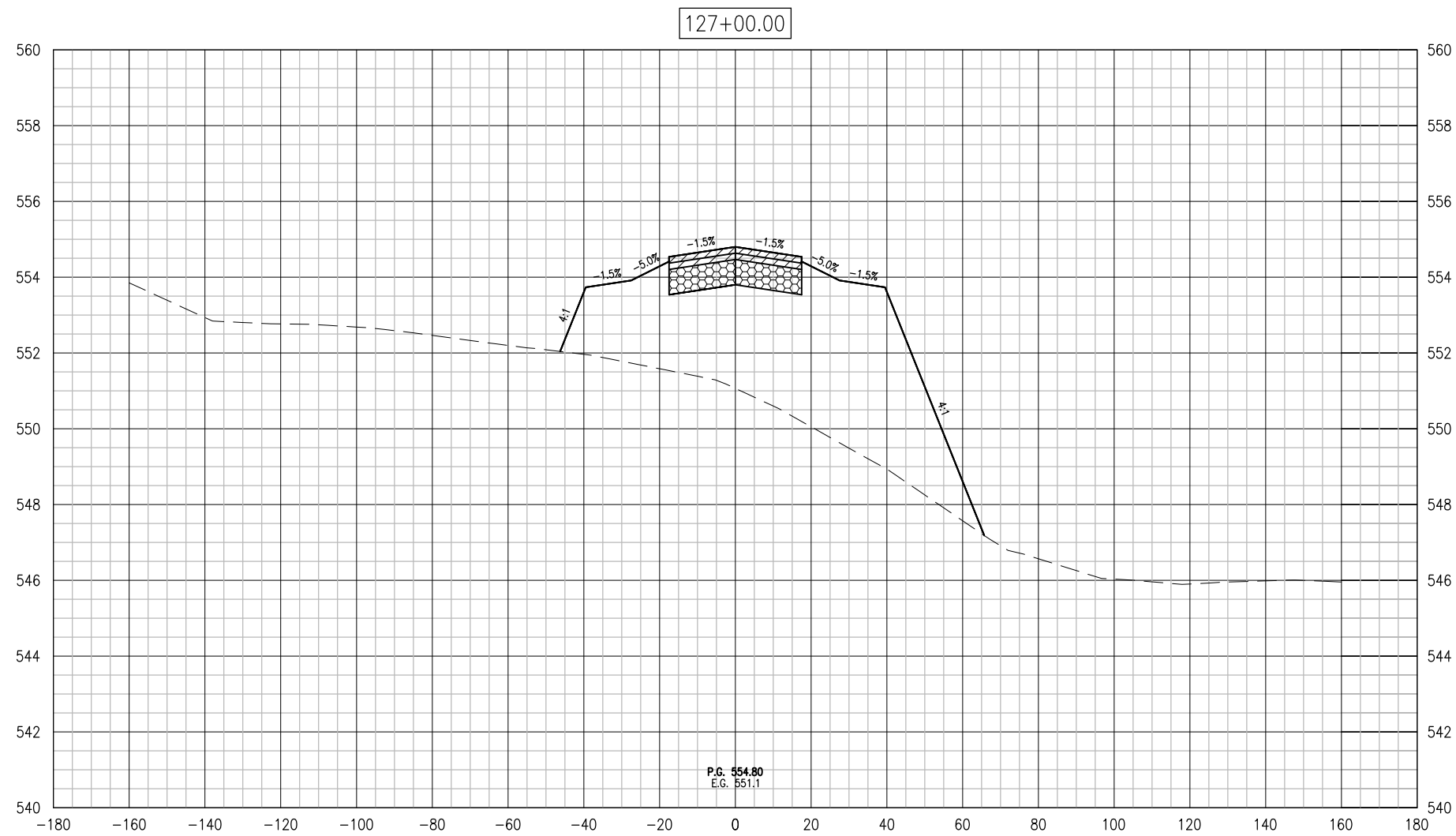

DATE	REVISION

MARSHALL COUNTY AIRPORT
 LACON, ILLINOIS

IL PROJ.: C75-4218 BLOCK GRANT: 3-17-0059-B14

Hanson Project No. 09A0031	LAYOUT MLH 12/06/12
Filename C-301-XS.dwg	DRAWN MLH 12/06/12
Scale 1" = 20'H 1" = 2'V	REVIEWED BSS 01/11/13
Date 01/11/13	



CONSTRUCT A 2,065' X 35'
 PARTIAL PARALLEL TAXIWAY
 TO RUNWAY 13/31

CROSS SECTIONS STA. 127+00

JAN 11, 2013 1:18 PM HARR01115
 pw:\s\spi-svr306\hanson.dom\hanson_projects\Documents\09\jobs\09A0031\09A0031D\CAD\Airport\Sheet\C-301-XS

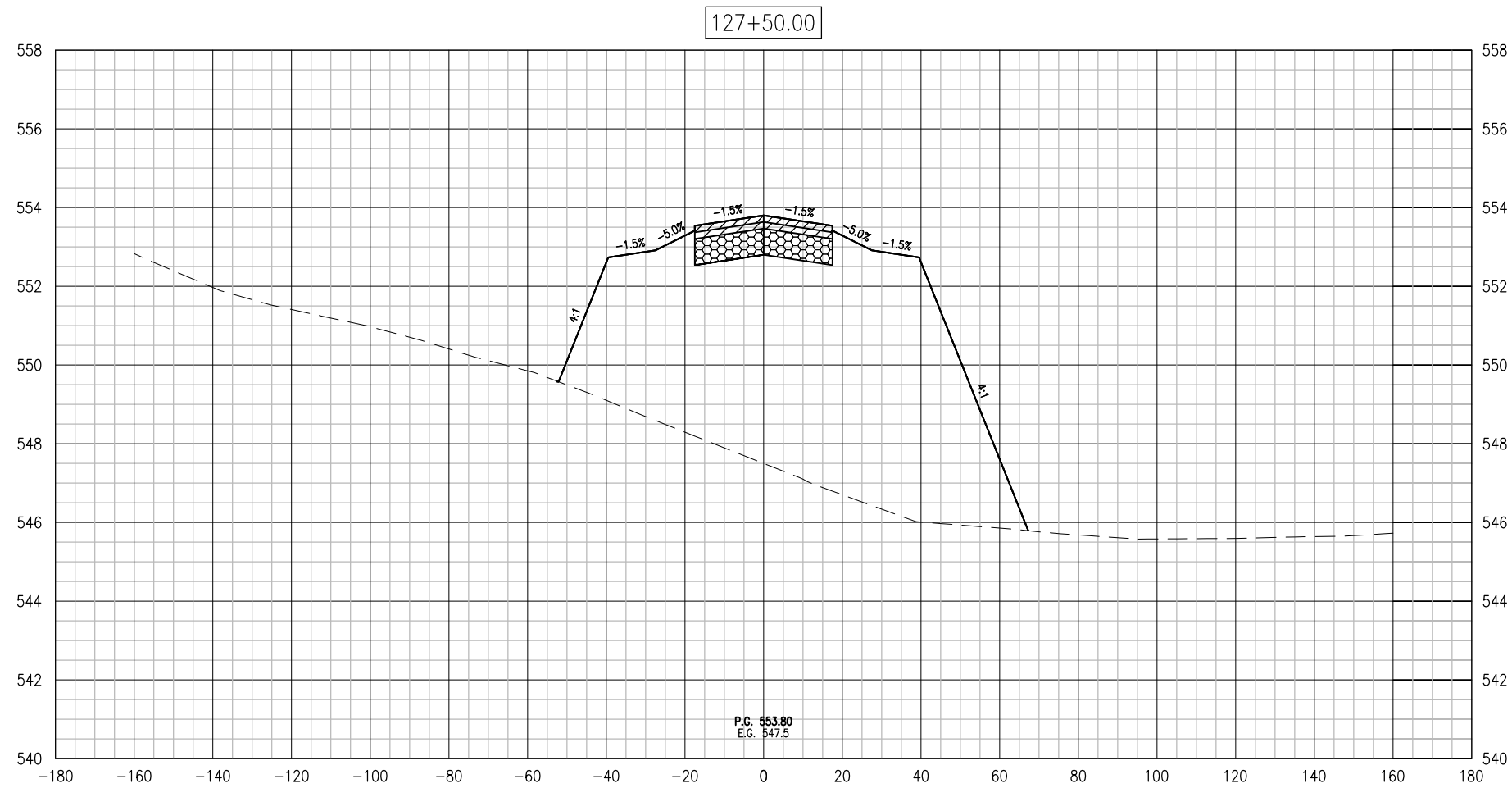

DATE	REVISION

**MARSHALL COUNTY AIRPORT
LACON, ILLINOIS**

IL PROJ.: C75-4218 BLOCK GRANT: 3-17-0059-B14

Hanson Project No.	09A0031
Filename	C-301-XS.dwg
Scale	1" = 20'H 1" = 2'V
Date	01/11/13

LAYOUT	MLH	12/06/12
DRAWN	MLH	12/06/12
REVIEWED	BSS	01/11/13



© Copyright Hanson Professional Services Inc. 2013
Hanson Professional Services Inc.
 1525 John H. Brown St.
 Springfield, Illinois 62703-2886

CONSTRUCT A 2,065' X 35'
 PARTIAL PARALLEL TAXIWAY
 TO RUNWAY 13/31

CROSS SECTIONS STA. 127+50

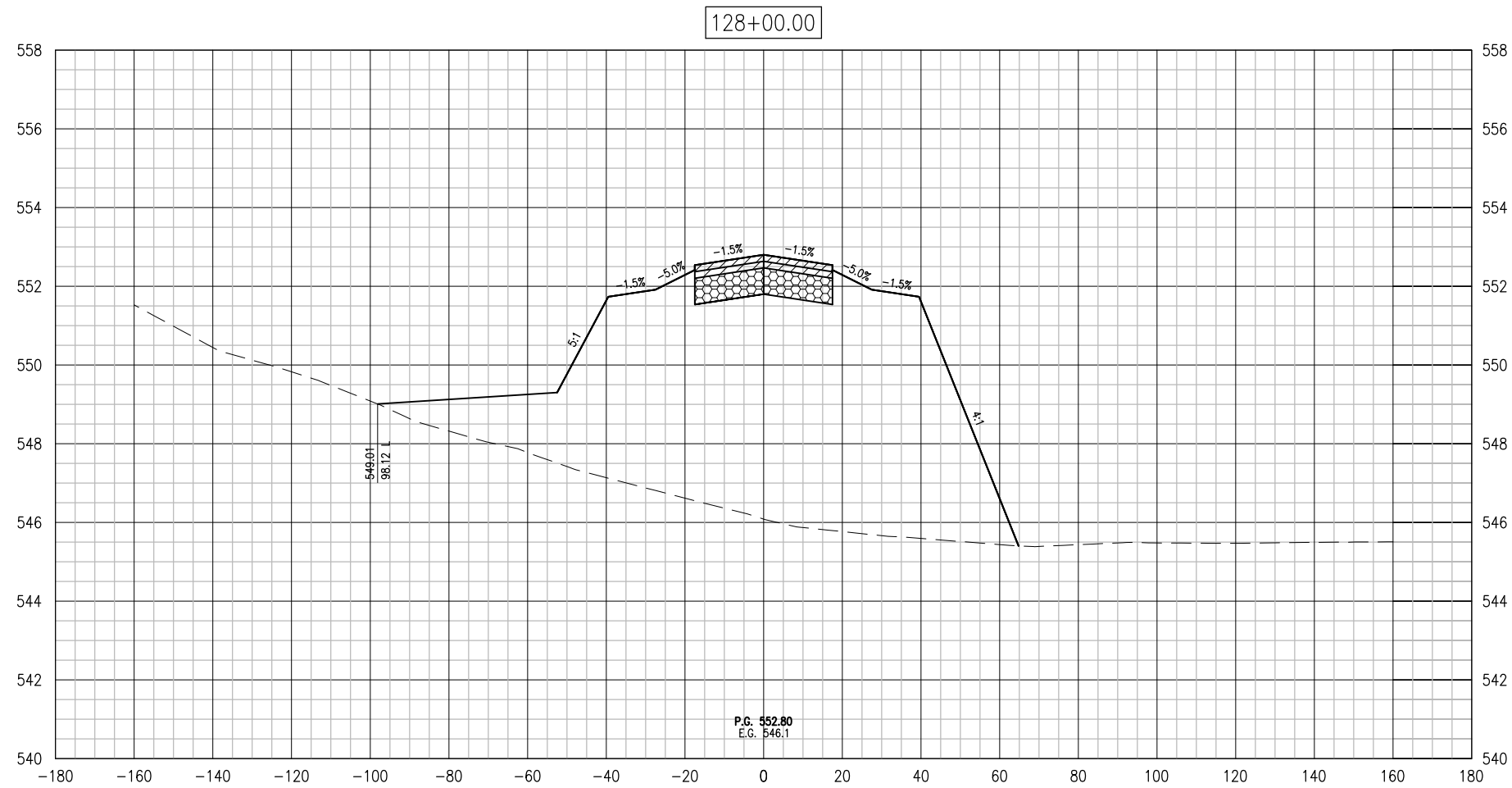

DATE	REVISION

MARSHALL COUNTY AIRPORT
 LACON, ILLINOIS

IL PROJ.: C75-4218 BLOCK GRANT: 3-17-0059-B14

Hanson Project No.	09A0031
Filename	C-301-XS.dwg
Scale	1" = 20'H 1" = 2'V
Date	01/11/13

LAYOUT	MLH	12/06/12
DRAWN	MLH	12/06/12
REVIEWED	BSS	01/11/13



© Copyright Hanson Professional Services Inc. 2013
 Hanson Professional Services Inc.
 1525 John H. Brown Sr. Blvd.
 Springfield, Illinois 62703-2886

CONSTRUCT A 2,065' X 35'
 PARTIAL PARALLEL TAXIWAY
 TO RUNWAY 13/31

CROSS SECTIONS STA. 128+00

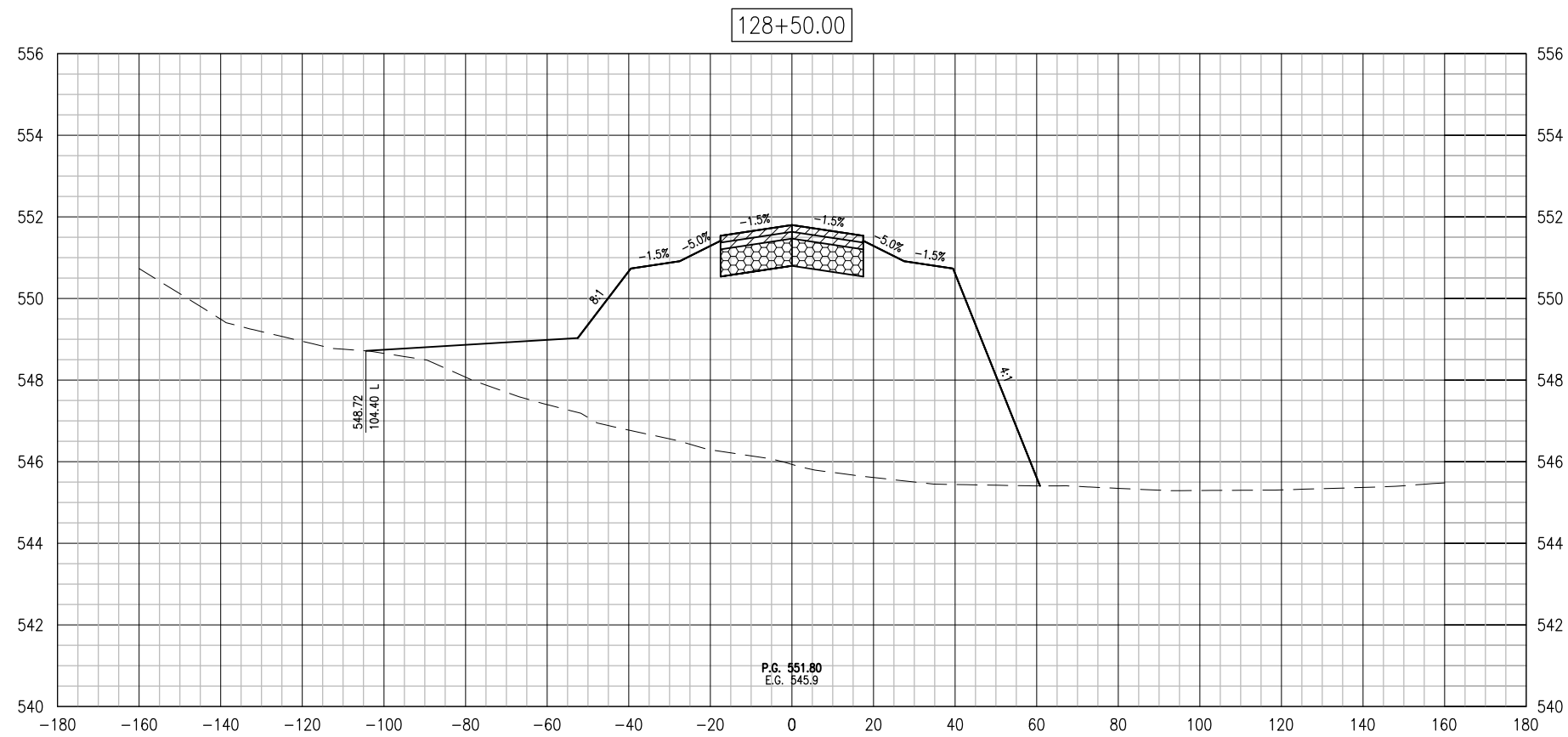
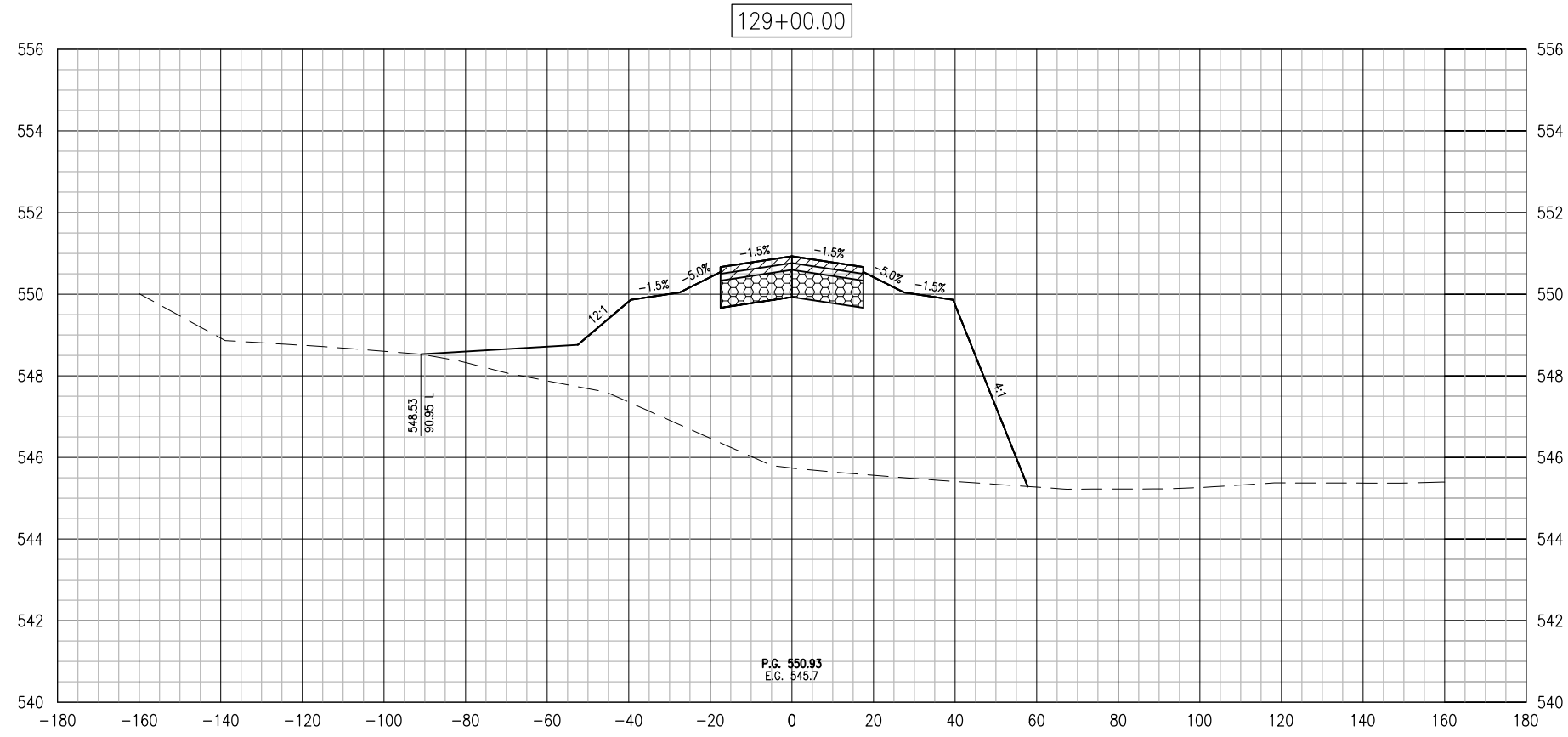

JAN 11, 2013 1:18 PM HARR01115
 pw:\sps-svc\06.hanson.com\hanson_projects\Documents\09a\031\09a0031\CAD\Airport\Sheet\C-301-XS

REVISION	DATE

MARSHALL COUNTY AIRPORT
 LACON, ILLINOIS

IL PROJ.: C75-4218 BLOCK GRANT: 3-17-0059-B14

Hanson Project No.	09A0031
Filename	C-301-XS.dwg
Scale	1" = 20'H 1" = 2'V
Date	01/11/13
LAYOUT	MLH 12/06/12
DRAWN	MLH 12/06/12
REVIEWED	BSS 01/11/13



CONSTRUCT A 2,065' X 35'
 PARTIAL PARALLEL TAXIWAY
 TO RUNWAY 13/31

CROSS SECTIONS STA. 128+50
 TO STA. 129+00

JAN 11, 2013 1:18 PM HARR01115
 pw:\s\spi-svr306\hanson\dom\hanson_projects\Documents\09\jobs\09A0031\09A0031D\CAD\Airport\Sheet\C-301-XS

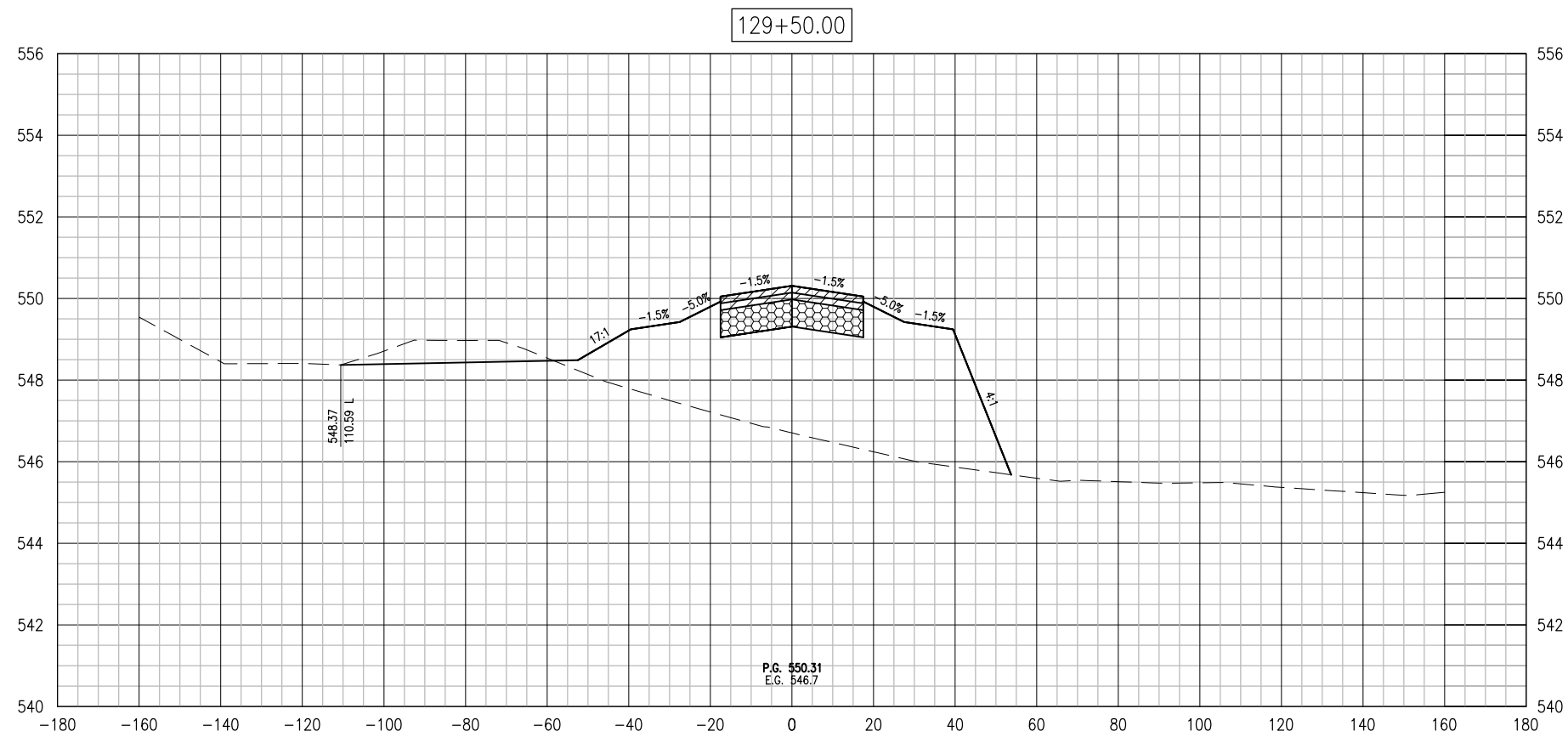
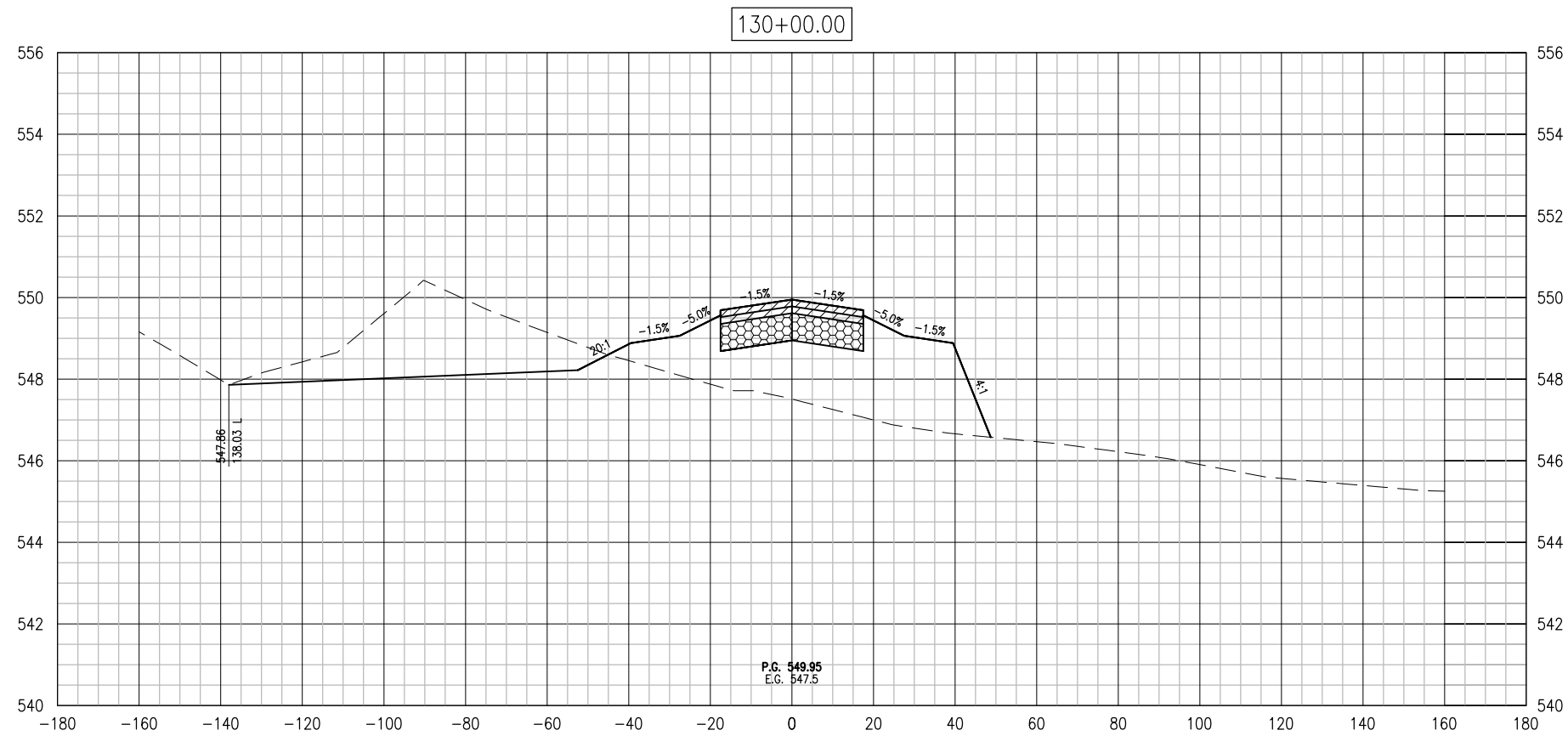

REVISION	DATE

MARSHALL COUNTY AIRPORT
LACON, ILLINOIS

IL PROJ.: C75-4218 BLOCK GRANT: 3-17-0059-B14

Hanson Project No.	09A0031
Filename	C-301-XS.dwg
Scale	1" = 20'H 1" = 2'V
Date	01/11/13
LAYOUT	MLH 12/06/12
DRAWN	MLH 12/06/12
REVIEWED	BSS 01/11/13



CONSTRUCT A 2,065' X 35'
PARTIAL PARALLEL TAXIWAY
TO RUNWAY 13/31

CROSS SECTIONS STA. 129+50
TO STA. 130+00

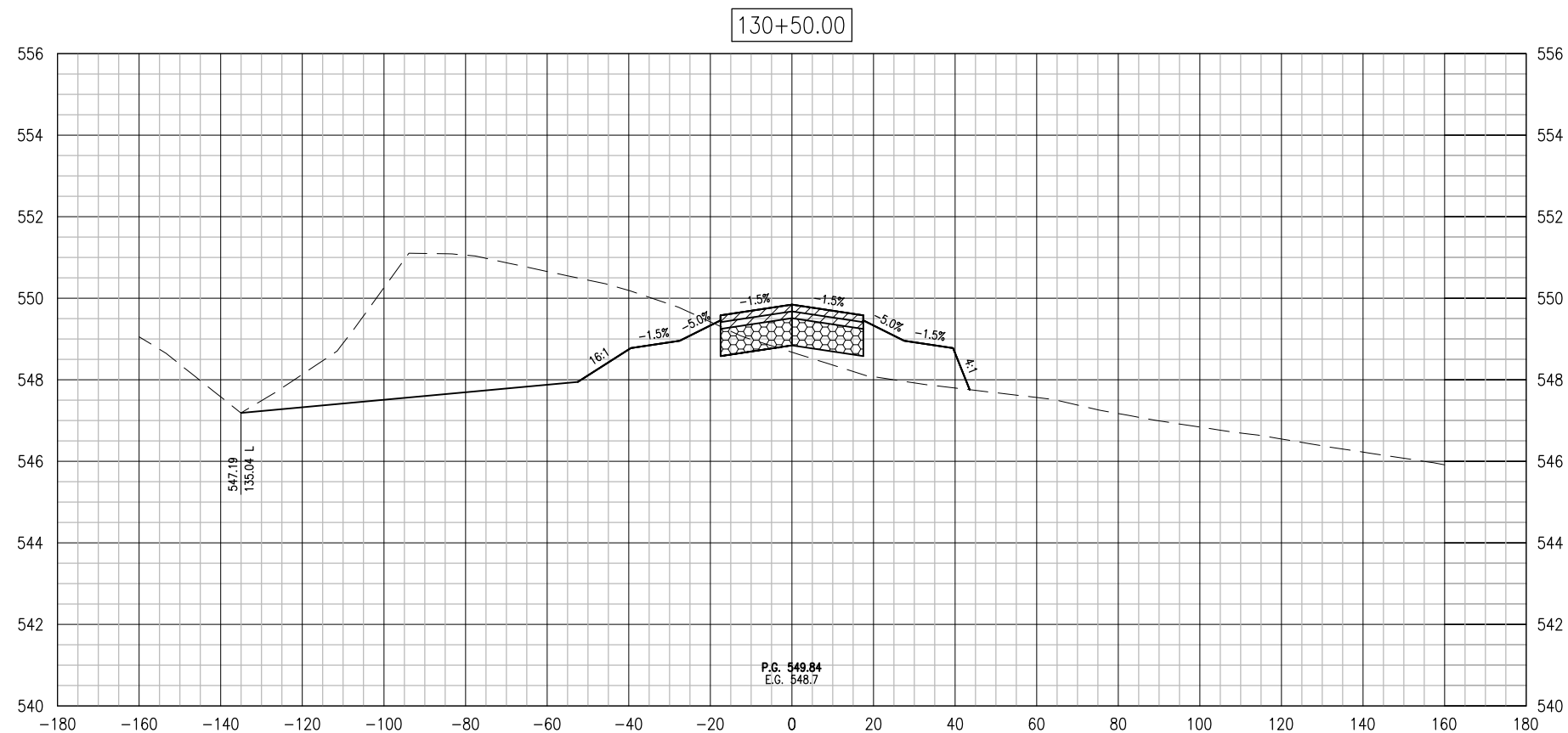

JAN 11, 2013 1:18 PM HARR01115
 pw:\s\spi-svr306\hanson\Documents\09\jobs\09A0031\09A0031D\CAD\Airport\Sheet\C-301-XS

REVISION	DATE

MARSHALL COUNTY AIRPORT
 LACON, ILLINOIS

IL PROJ.: C75-4218 BLOCK GRANT: 3-17-0059-B14

Hanson Project No.	09A0031
Filename	C-301-XS.dwg
Scale	1" = 20'H 1" = 2'V
Date	01/11/13
LAYOUT	MLH 12/06/12
DRAWN	MLH 12/06/12
REVIEWED	BSS 01/11/13



© Copyright Hanson Professional Services Inc. 2013
 Hanson Professional Services Inc.
 1525 Old Orchard Street
 Springfield, Illinois 62703-2886

CONSTRUCT A 2,065' X 35'
 PARTIAL PARALLEL TAXIWAY
 TO RUNWAY 13/31

CROSS SECTIONS STA. 130+50
 TO STA. 131+00

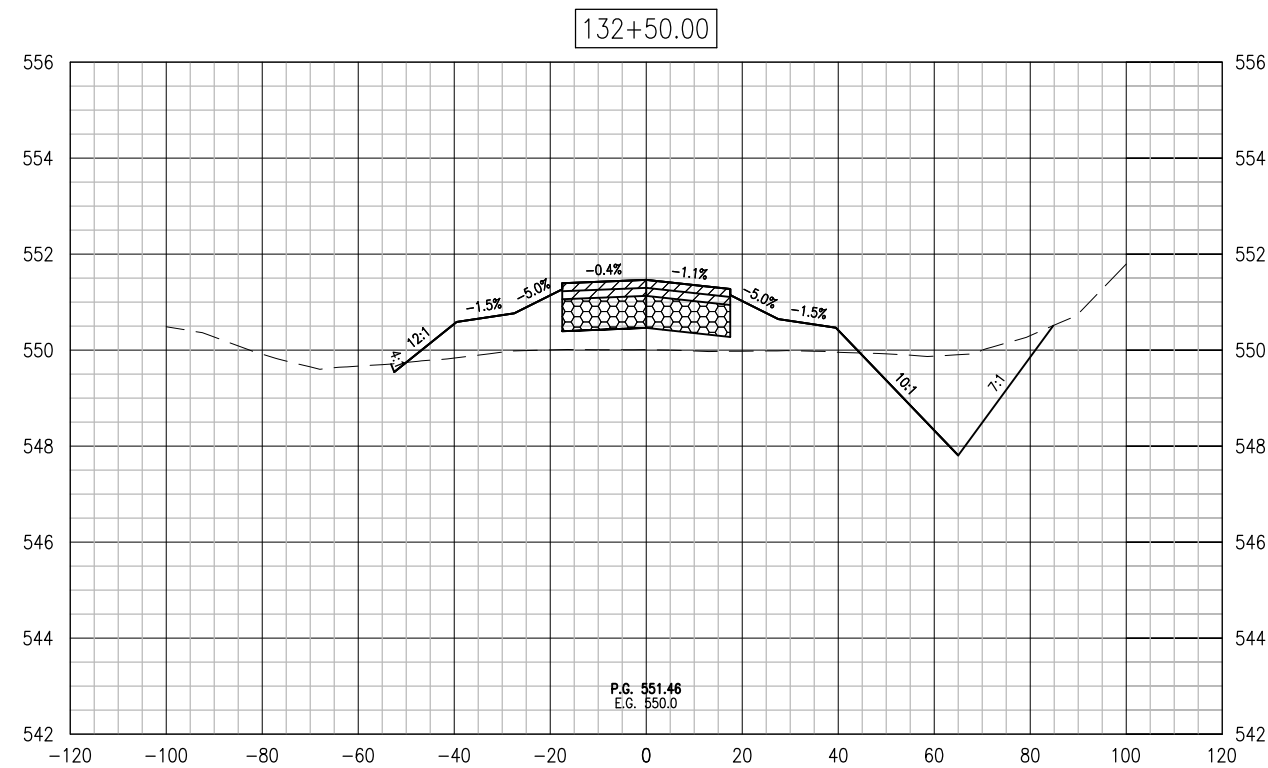
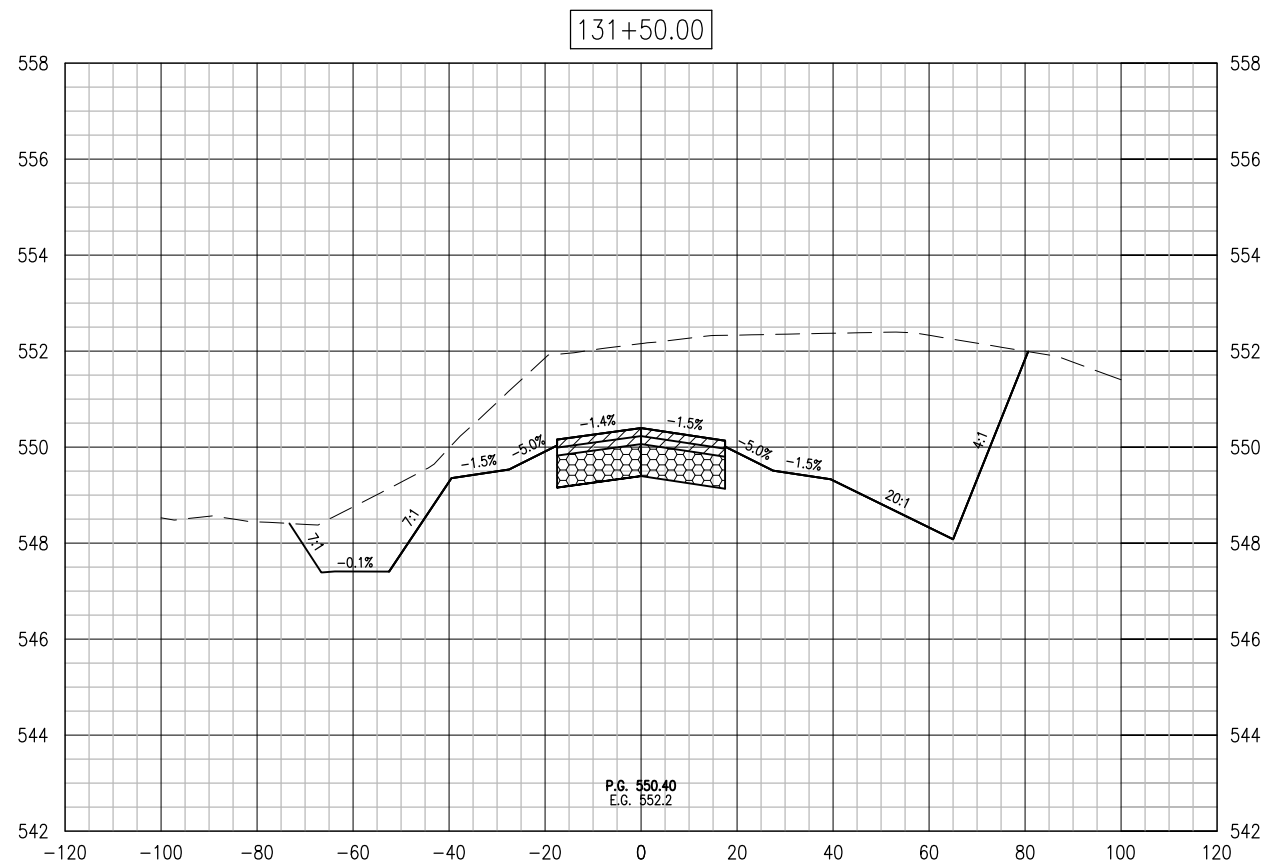
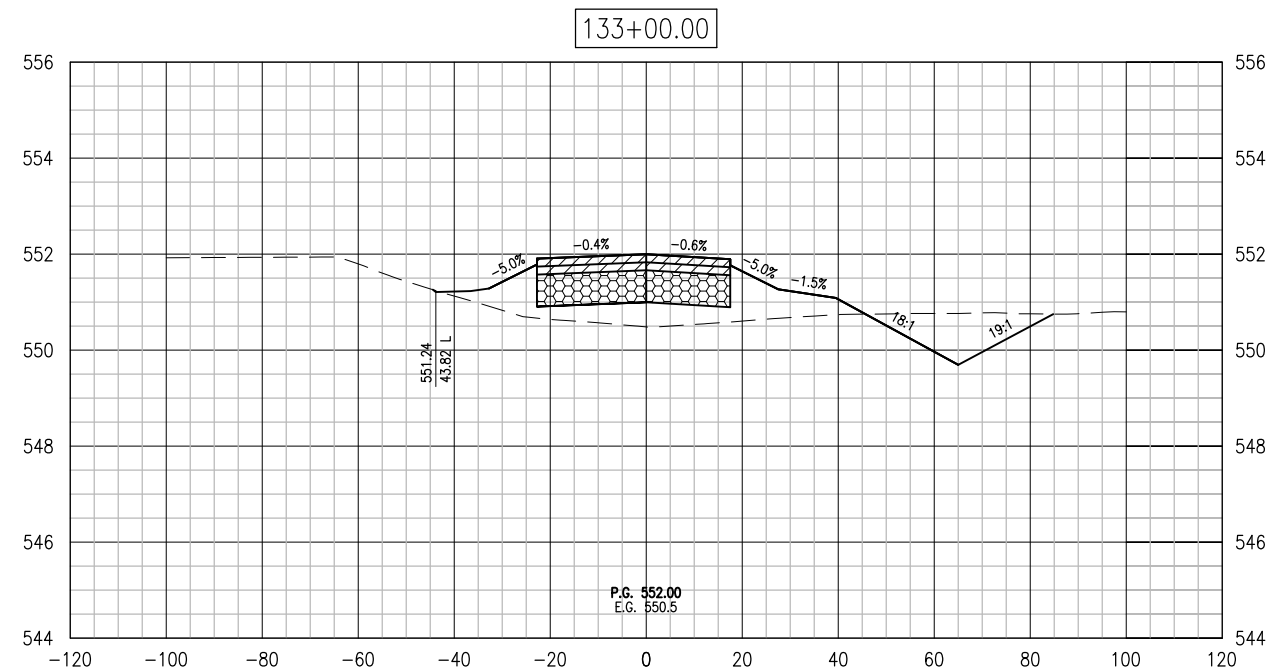
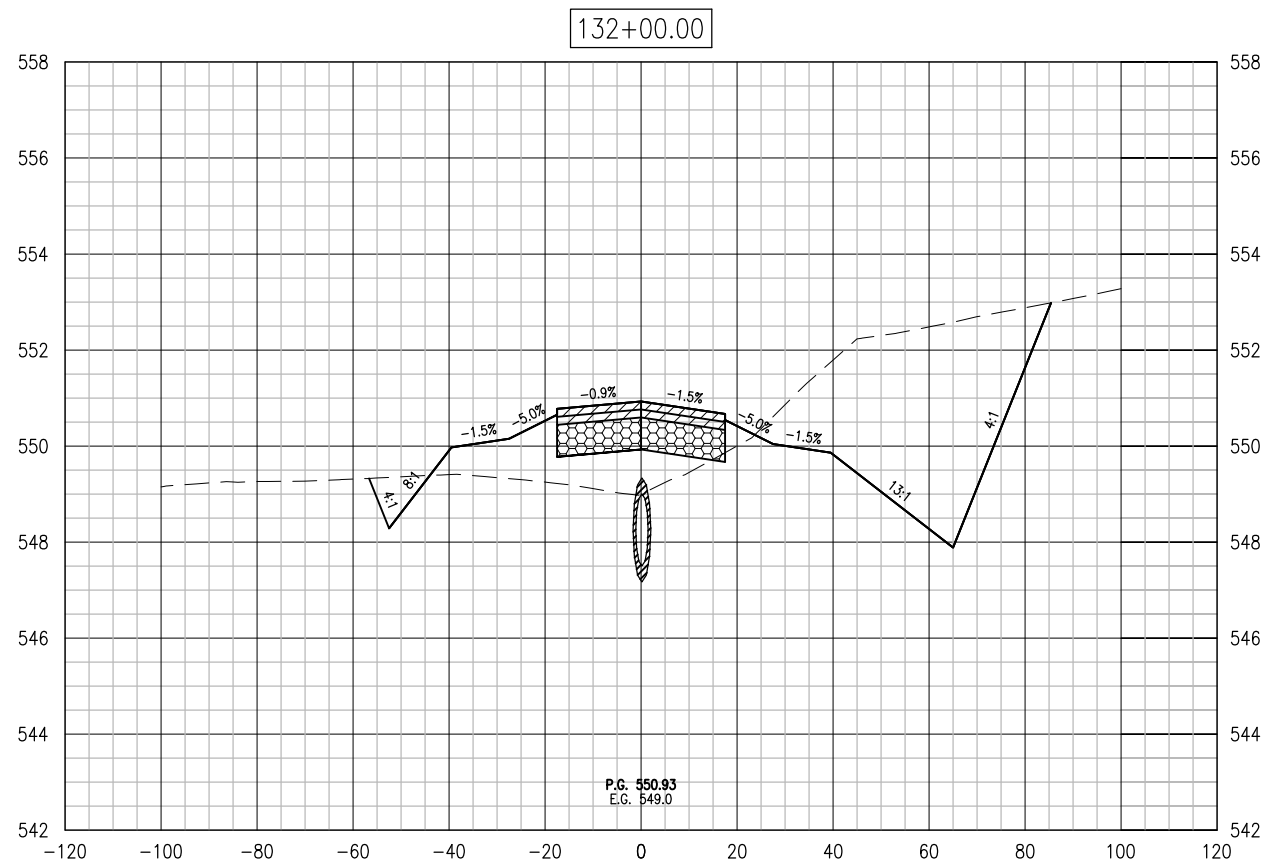

REVISION	DATE

MARSHALL COUNTY AIRPORT
LACON, ILLINOIS

IL PROJ.: C75-4218 BLOCK GRANT: 3-17-0059-B14

Hanson Project No.	09A0031
Filename	C-301-XS.dwg
Scale	1" = 20'H, 1" = 2'V
Date	01/11/13
LAYOUT	MLH 12/06/12
DRAWN	MLH 12/06/12
REVIEWED	BSS 01/11/13



CONSTRUCT A 2,065' X 35'
PARTIAL PARALLEL TAXIWAY
TO RUNWAY 13/31

CROSS SECTIONS STA. 131+50
TO STA. 133+00

JAN 11, 2013 1:18 PM HARR01115
pw:\s\svr306\hanson.dom\hanson Projects\Documents\09\jobs\09A0031\09A0031D\CAD\Airport\Sheet\C-301-XS

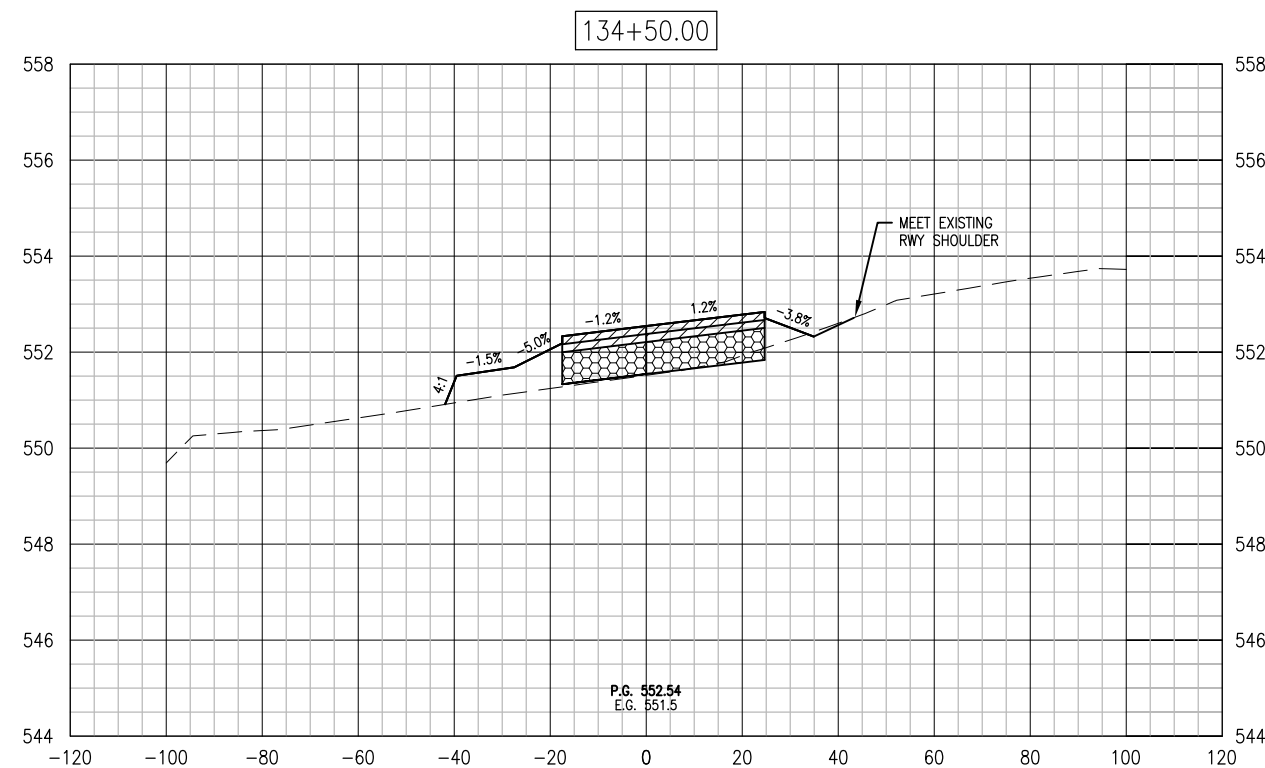
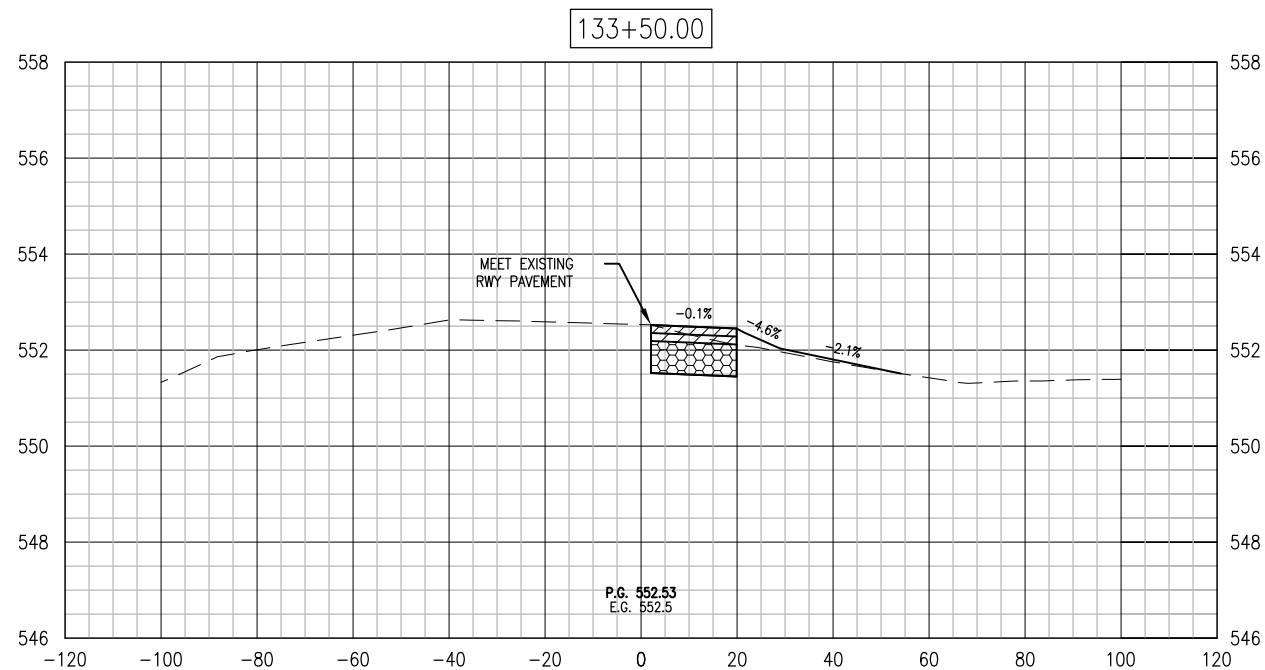
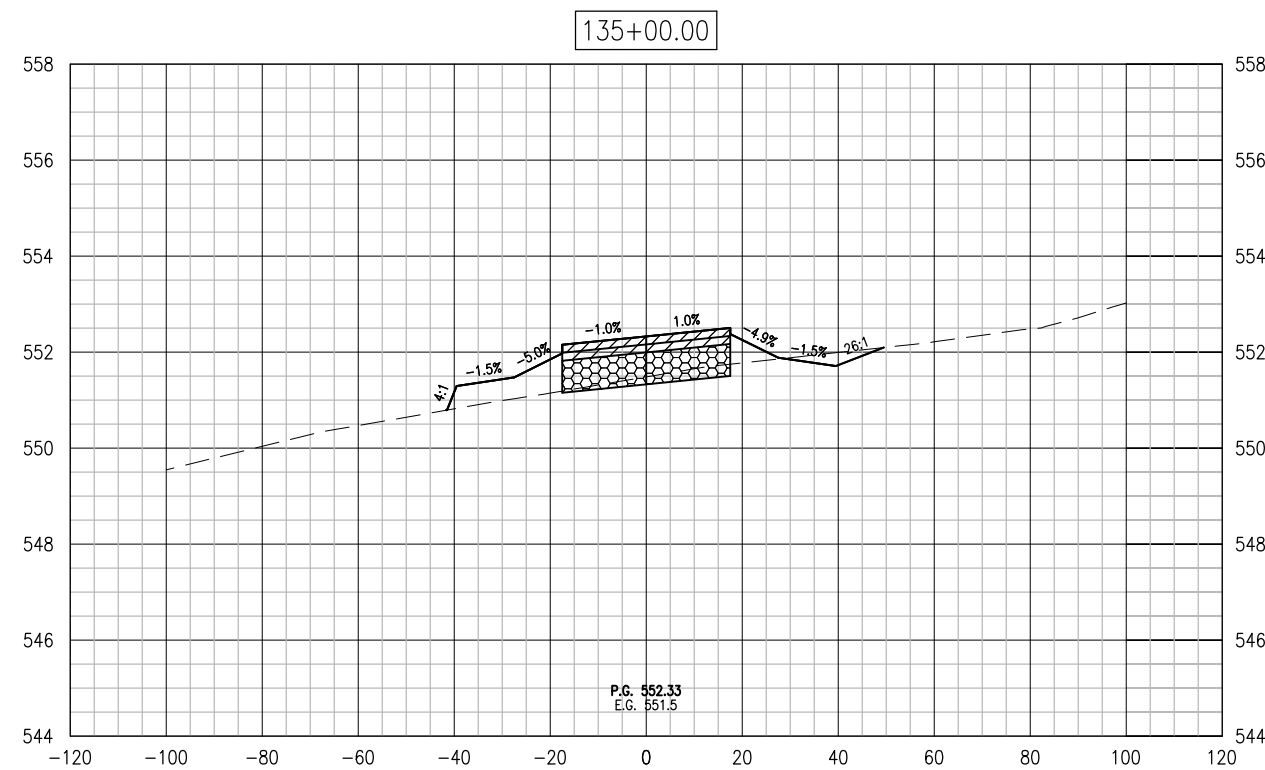
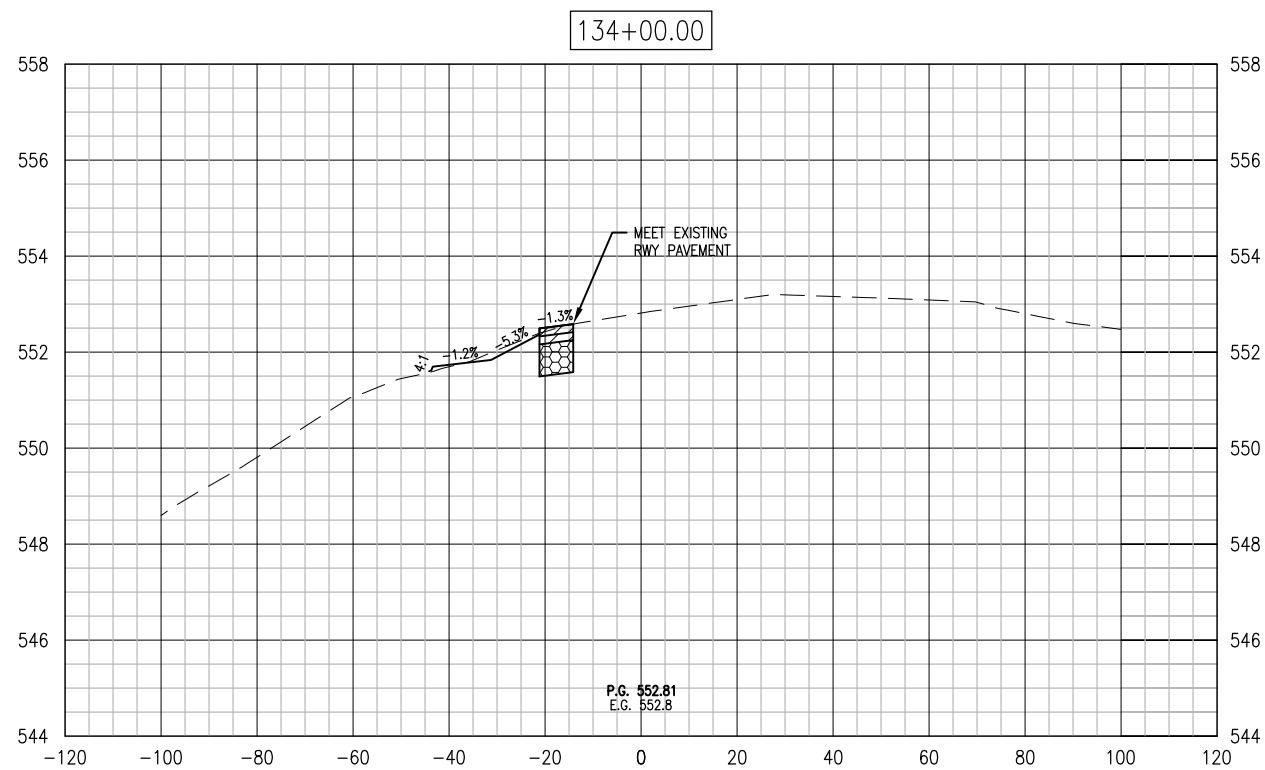

JAN 11, 2013 1:18 PM HARR01115
 pw:\s\svr306\hanson.dom\hanson_projects\Documents\09\jobs\09A0031\09A0031D\CAD\Airport\Sheet\C-301-XS

REVISION	DATE

MARSHALL COUNTY AIRPORT
 LACON, ILLINOIS

IL PROJ: C75-4218 BLOCK GRANT: 3-17-0059-B14

Hanson Project No.	09A0031
Filename	C-301-XS.dwg
Scale	1" = 20'H 1" = 2'V
Date	01/11/13
LAYOUT	MLH 12/06/12
DRAWN	MLH 12/06/12
REVIEWED	BSS 01/11/13



© Copyright Hanson Professional Services Inc. 2013
 Hanson Professional Services Inc.
 1525 North Rock Street
 Springfield, Illinois 62703-2886

CONSTRUCT A 2,065' X 35'
 PARTIAL PARALLEL TAXIWAY
 TO RUNWAY 13/31

CROSS SECTIONS STA. 133+50
 TO STA. 135+00

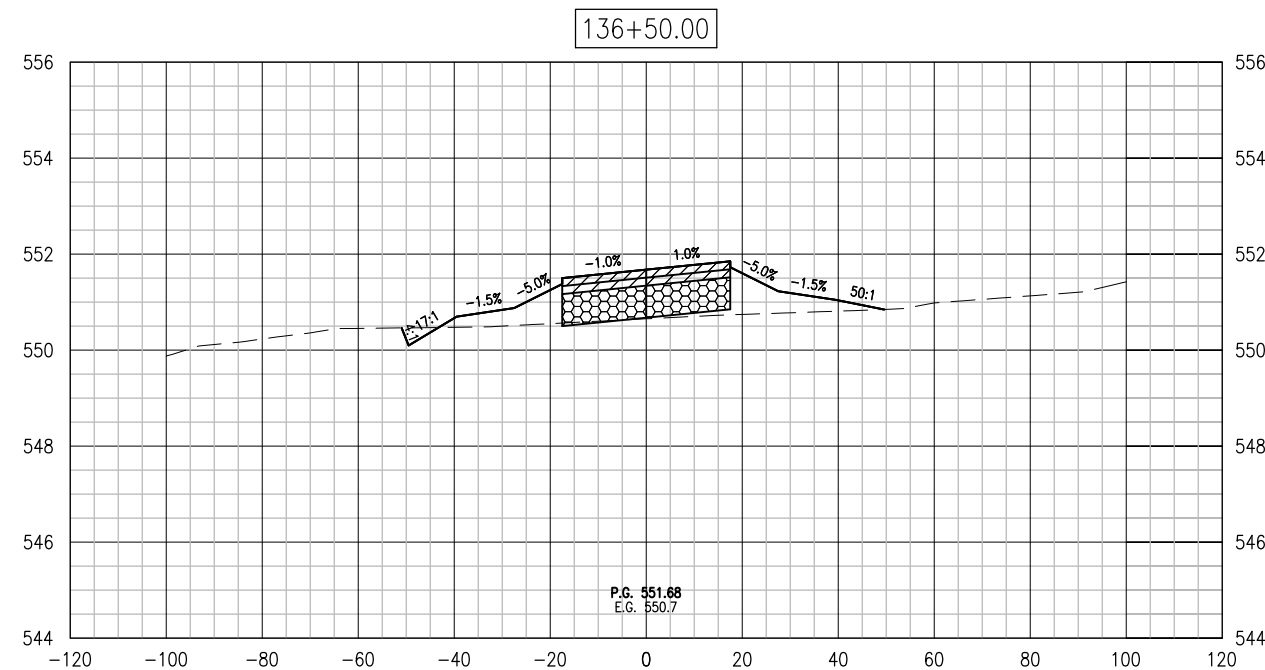
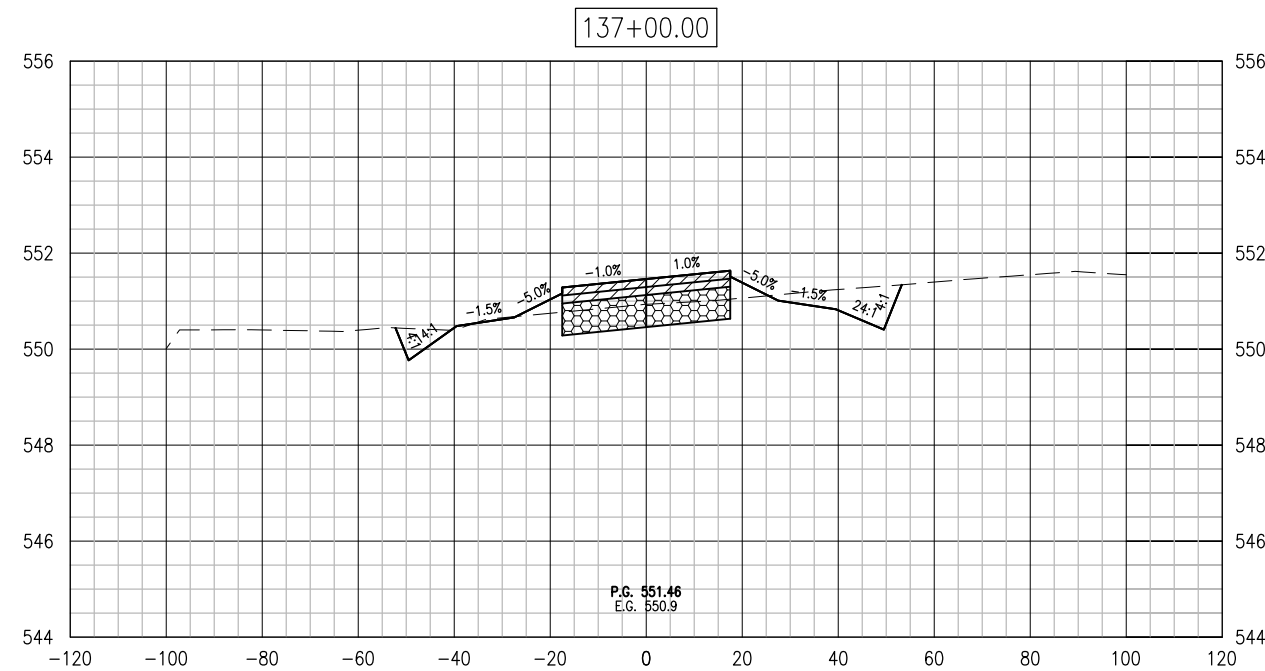
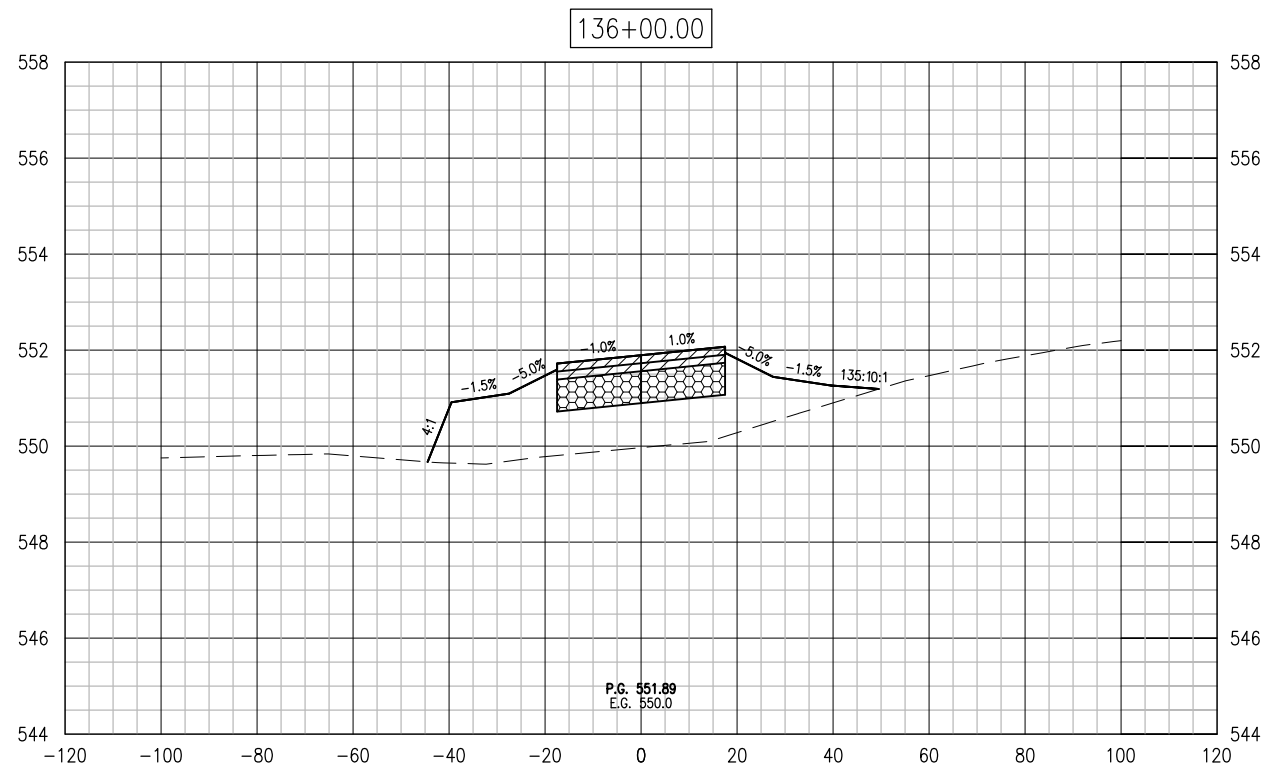

JAN 11, 2013 1:18 PM HARR01115
pw:\s\svr306\hanson\dom\hanson_projects\Documents\09\jobs\09A0031\09A0031D\CAD\Airport\Sheet\C-301-XS

REVISION	DATE

MARSHALL COUNTY AIRPORT
LACON, ILLINOIS

IL PROJ.: C75-4218 BLOCK GRANT: 3-17-0059-B14

Hanson Project No.	09A0031
Filename	C-301-XS.dwg
Scale	1" = 20'H 1" = 2'V
Date	01/11/13
LAYOUT	MLH 12/06/12
DRAWN	MLH 12/06/12
REVIEWED	BSS 01/11/13



CONSTRUCT A 2,065' X 35'
PARTIAL PARALLEL TAXIWAY
TO RUNWAY 13/31

CROSS SECTIONS STA. 135+50
TO STA. 137+00

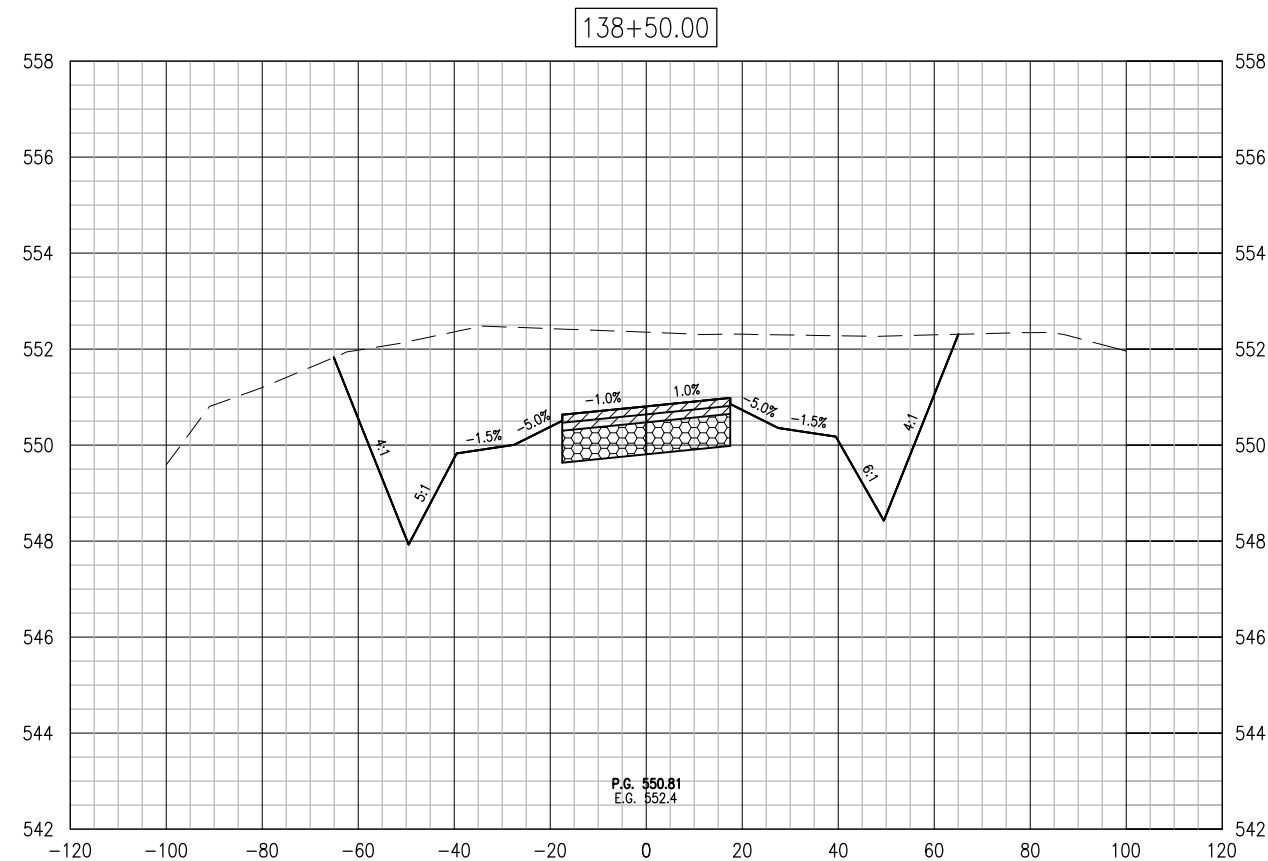
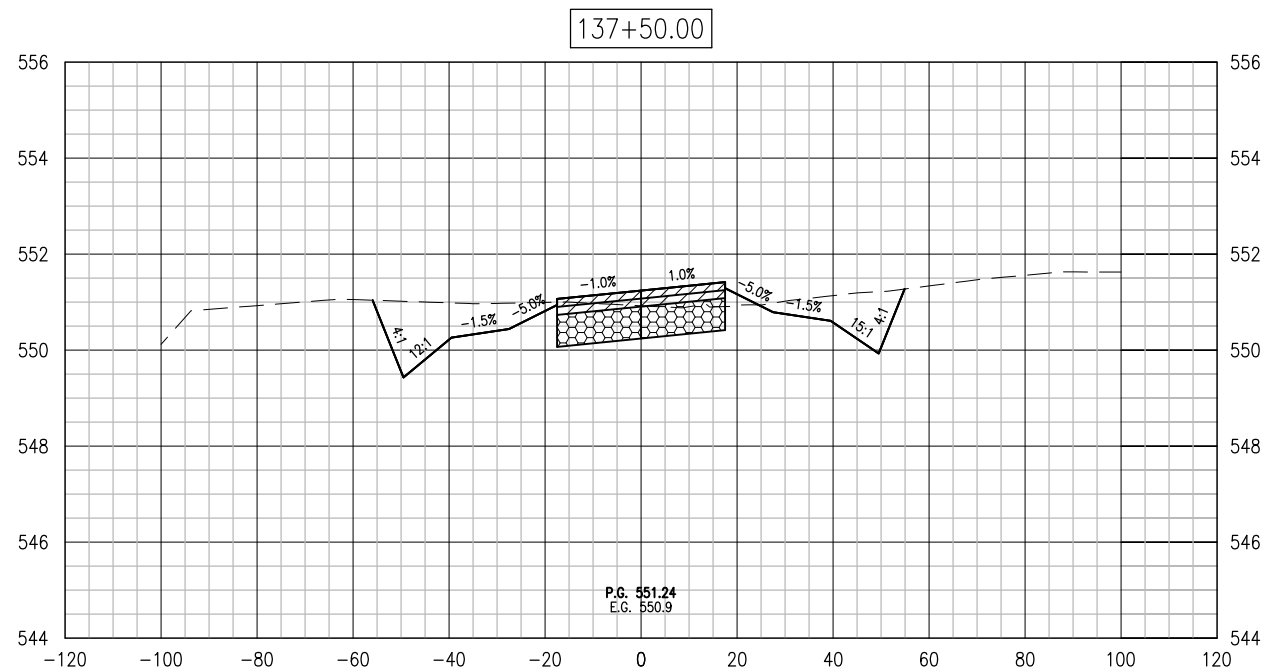
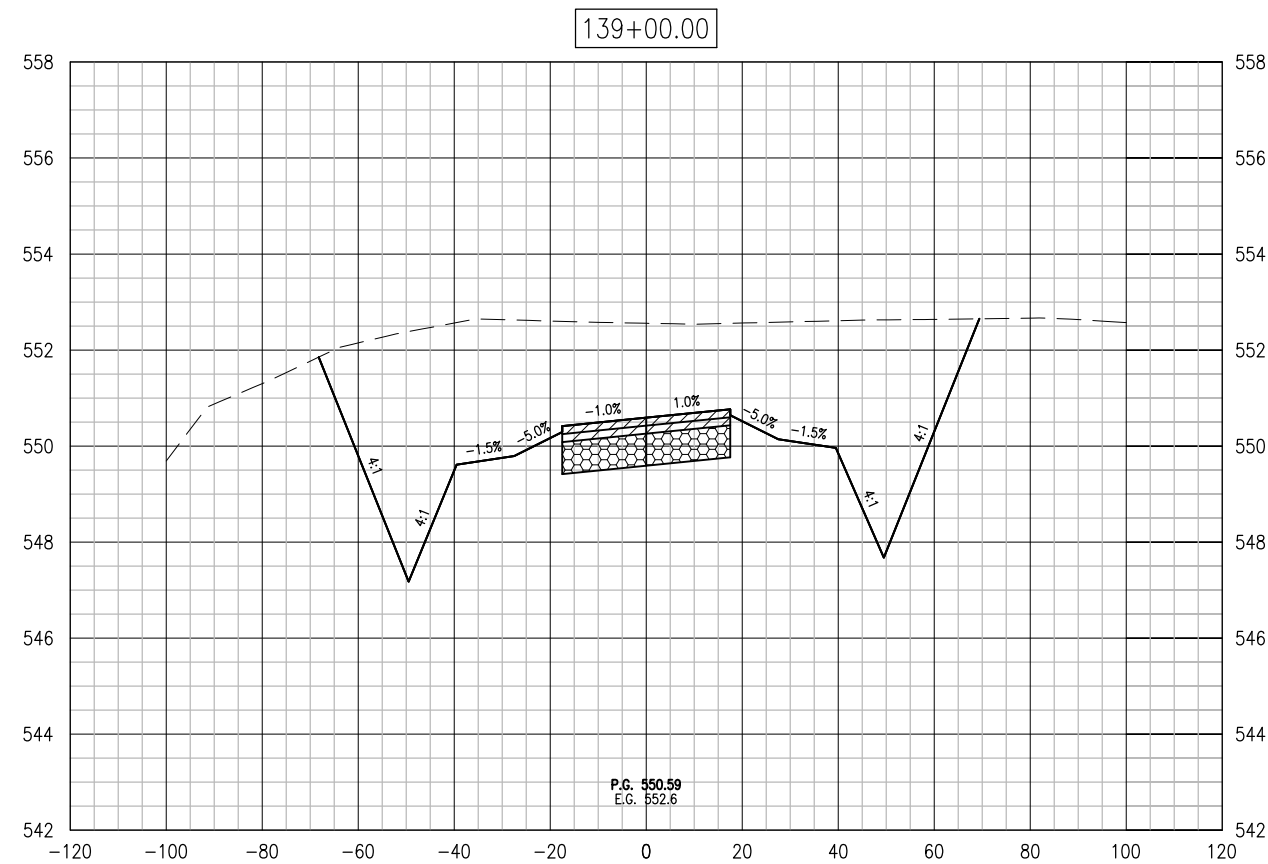
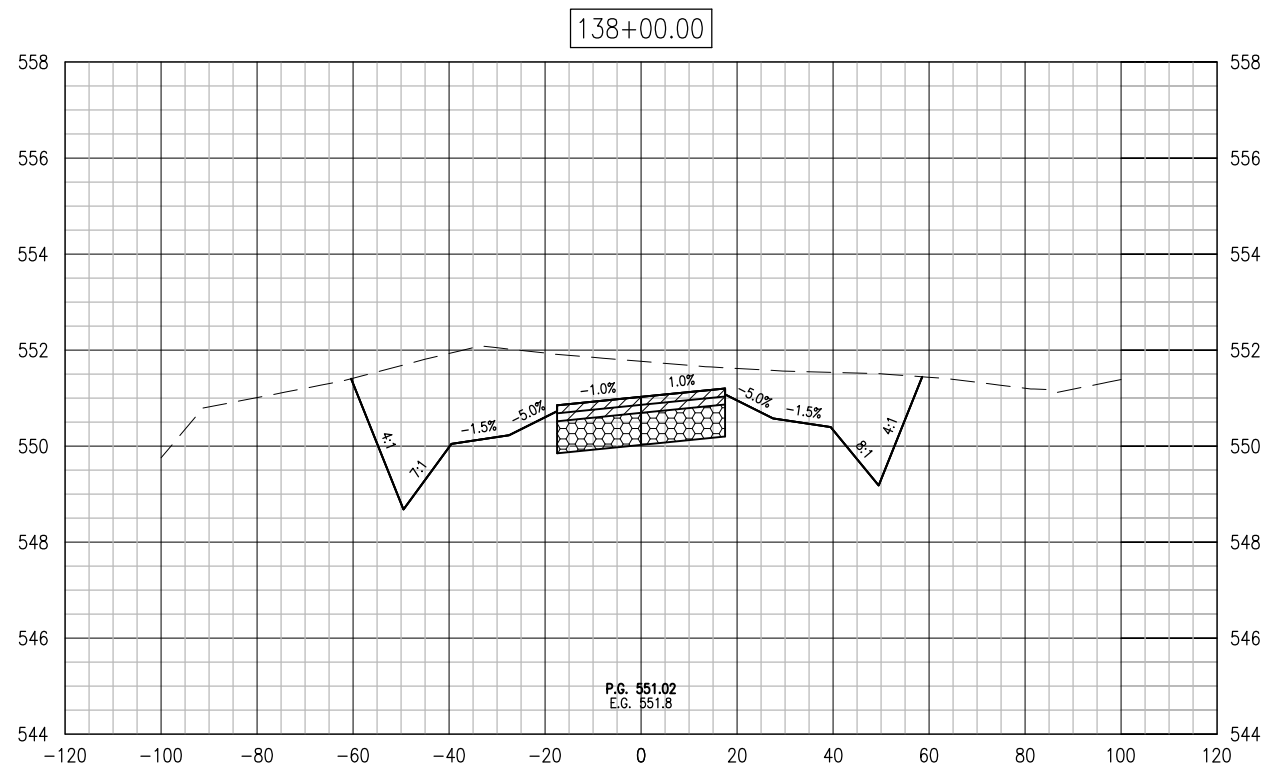

JAN 11, 2013 1:19 PM HARR01115
pw:\s\p\svr306\hanson\Documents\09\Jobs\09A0031\09A0031D\CAD\Airport\Sheet\C-301-XS

REVISION	DATE

MARSHALL COUNTY AIRPORT
LACON, ILLINOIS

IL PROJ.: C75-4218 BLOCK GRANT: 3-17-0059-B14

Hanson Project No.	09A0031
Filename	C-301-XS.dwg
Scale	1" = 20'H 1" = 2'V
Date	01/11/13
LAYOUT	MLH 12/06/12
DRAWN	MLH 12/06/12
REVIEWED	BSS 01/11/13



© Copyright Hanson Professional Services Inc. 2013
Hanson Professional Services Inc.
1525 North Rock Street
Springfield, Illinois 62703-2886

CONSTRUCT A 2,065' X 35'
PARTIAL PARALLEL TAXIWAY
TO RUNWAY 13/31

CROSS SECTIONS STA. 137+50
TO STA. 139+00

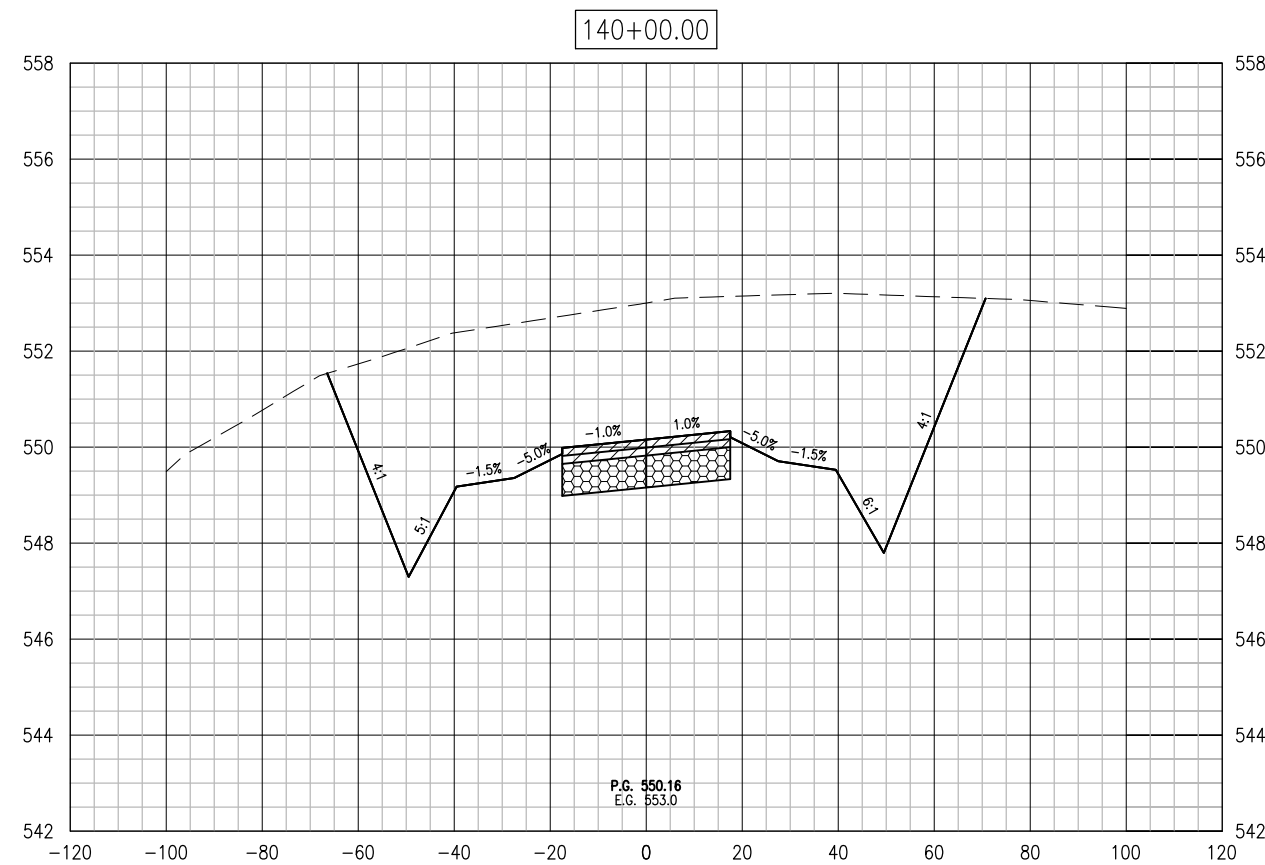
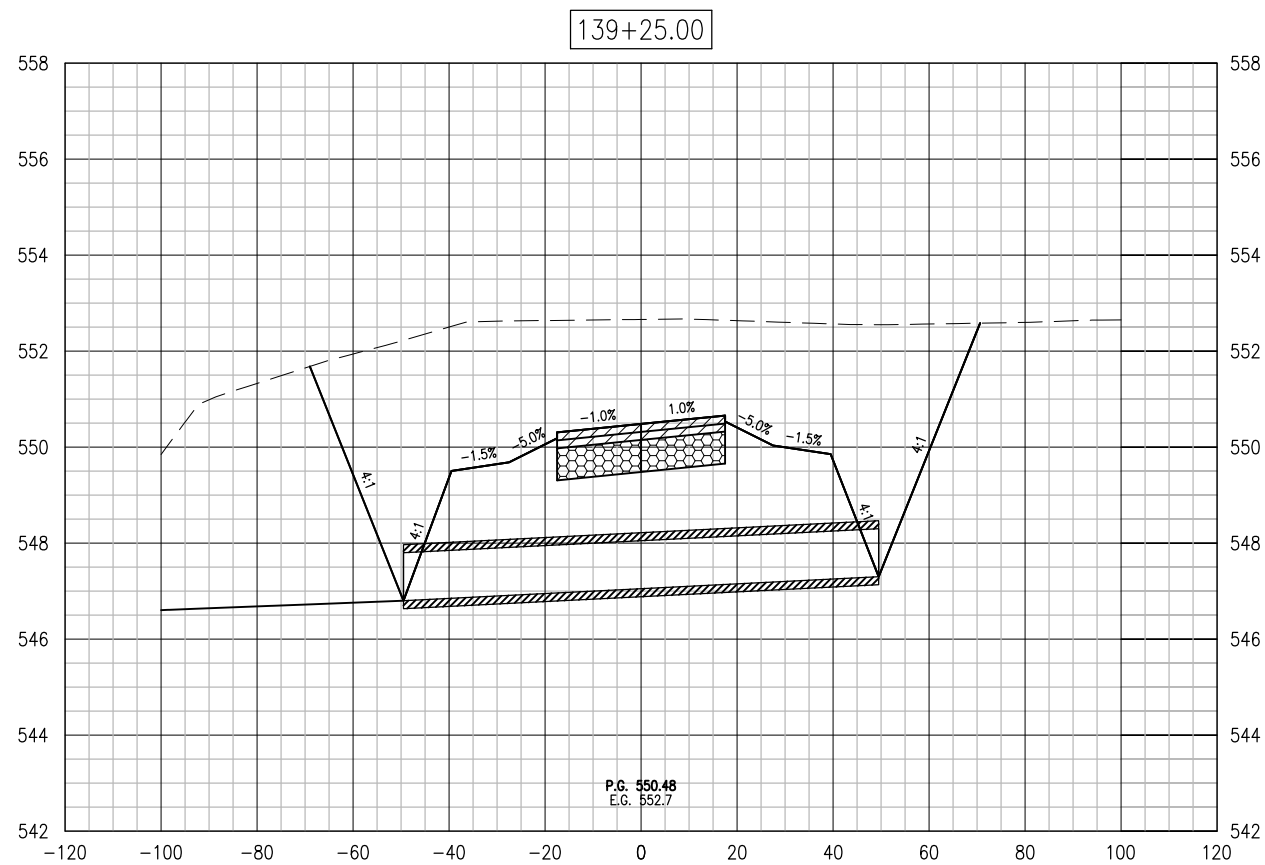
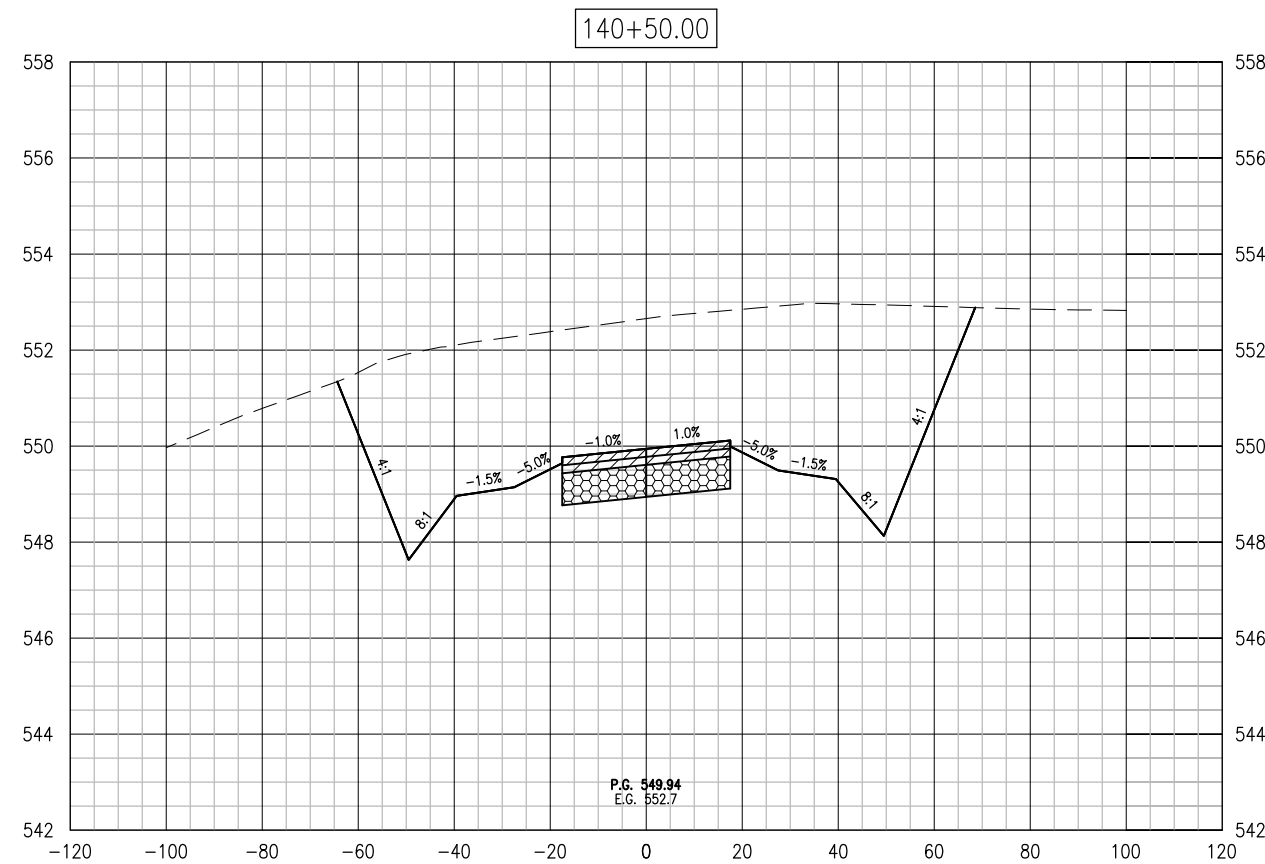
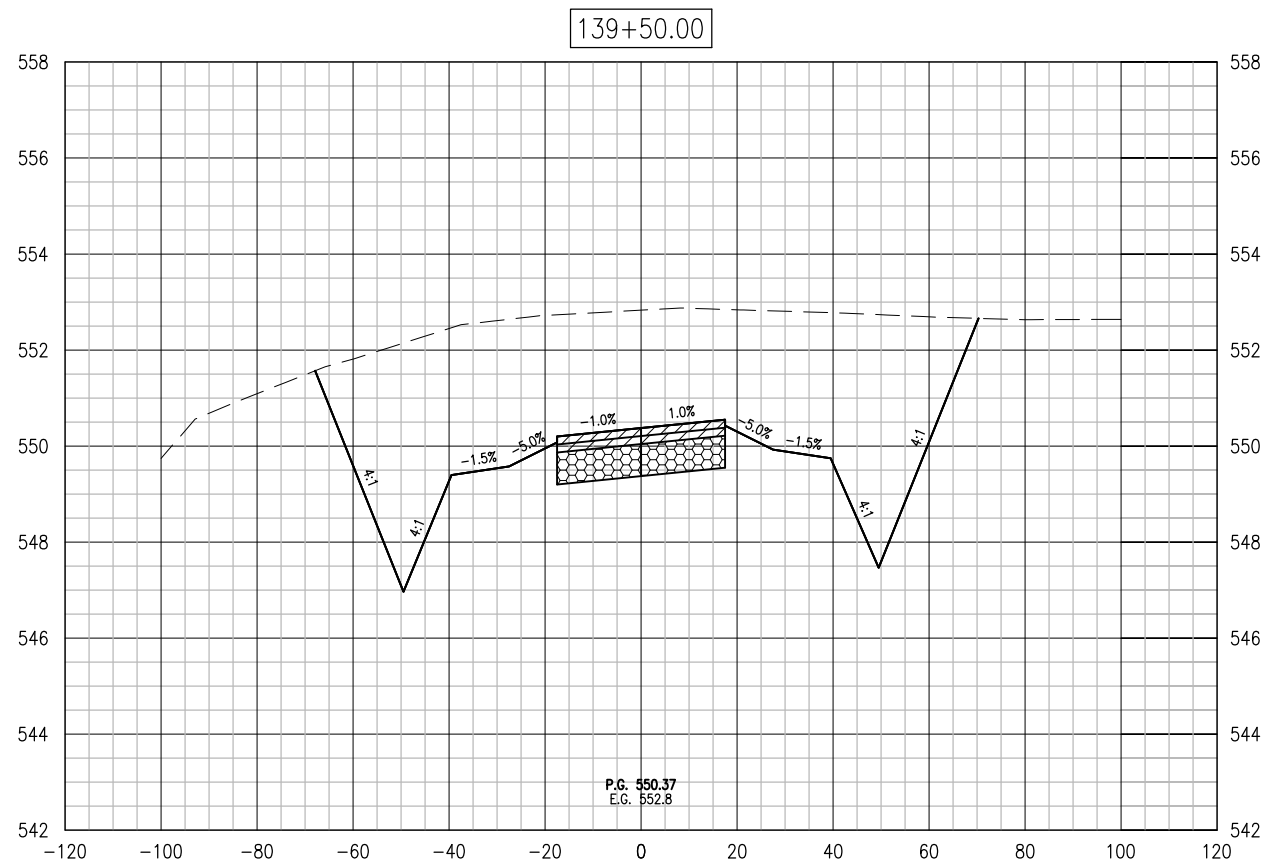

JAN 11, 2013 1:19 PM HARR01115
pw:\s\svr306\hanson\dom\hanson_projects\Documents\09\jobs\09A0031\09A0031D\CAD\Airport\Sheet\C-301-XS

REVISION	DATE

MARSHALL COUNTY AIRPORT
LACON, ILLINOIS

IL PROJ.: C75-4218 BLOCK GRANT: 3-17-0059-B14

FILENAME	SCALE	DATE	LAYOUT	MLH	12/06/12
C-301-XS.dwg	1" = 20'H 1" = 2'V	01/11/13			
			DRAWN	MLH	12/06/12
			REVIEWED	BSS	01/11/13

© Copyright Hanson Professional Services Inc. 2013
Hanson Professional Services Inc.
1525 North Lincoln Street
Springfield, Illinois 62703-2886

CONSTRUCT A 2,065' X 35'
PARTIAL PARALLEL TAXIWAY
TO RUNWAY 13/31

CROSS SECTIONS STA. 139+25
TO STA. 140+50

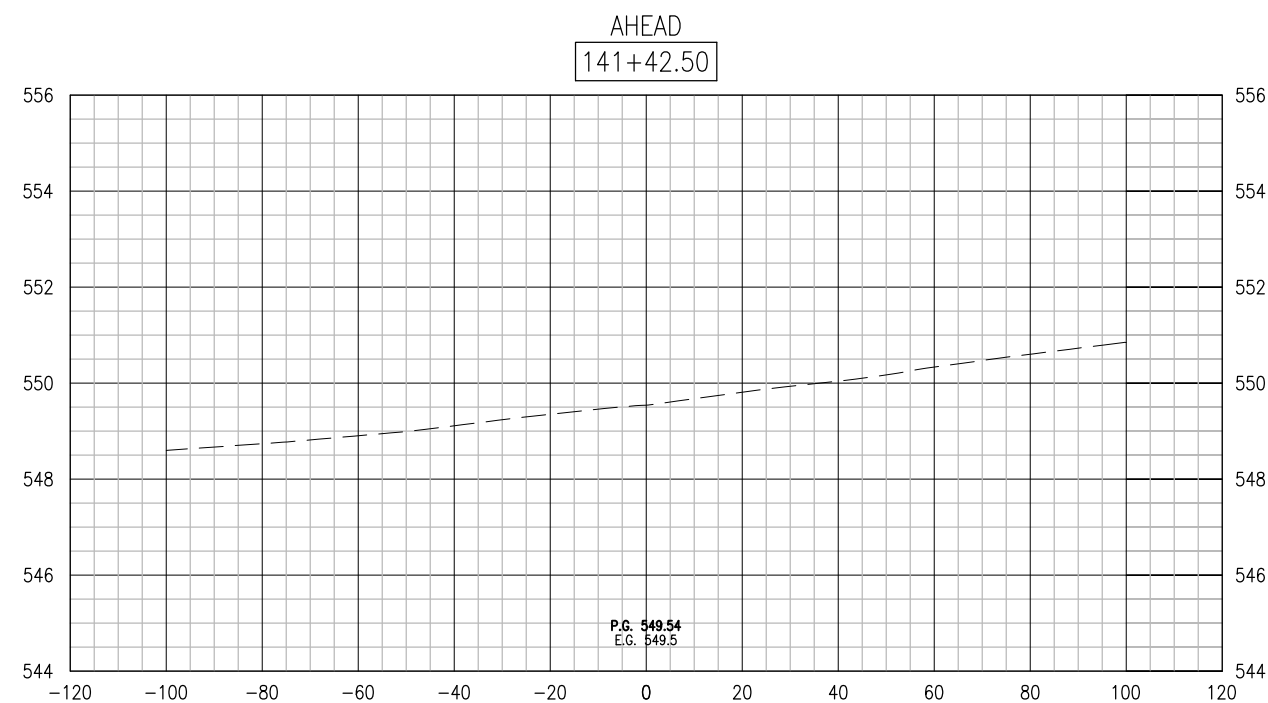
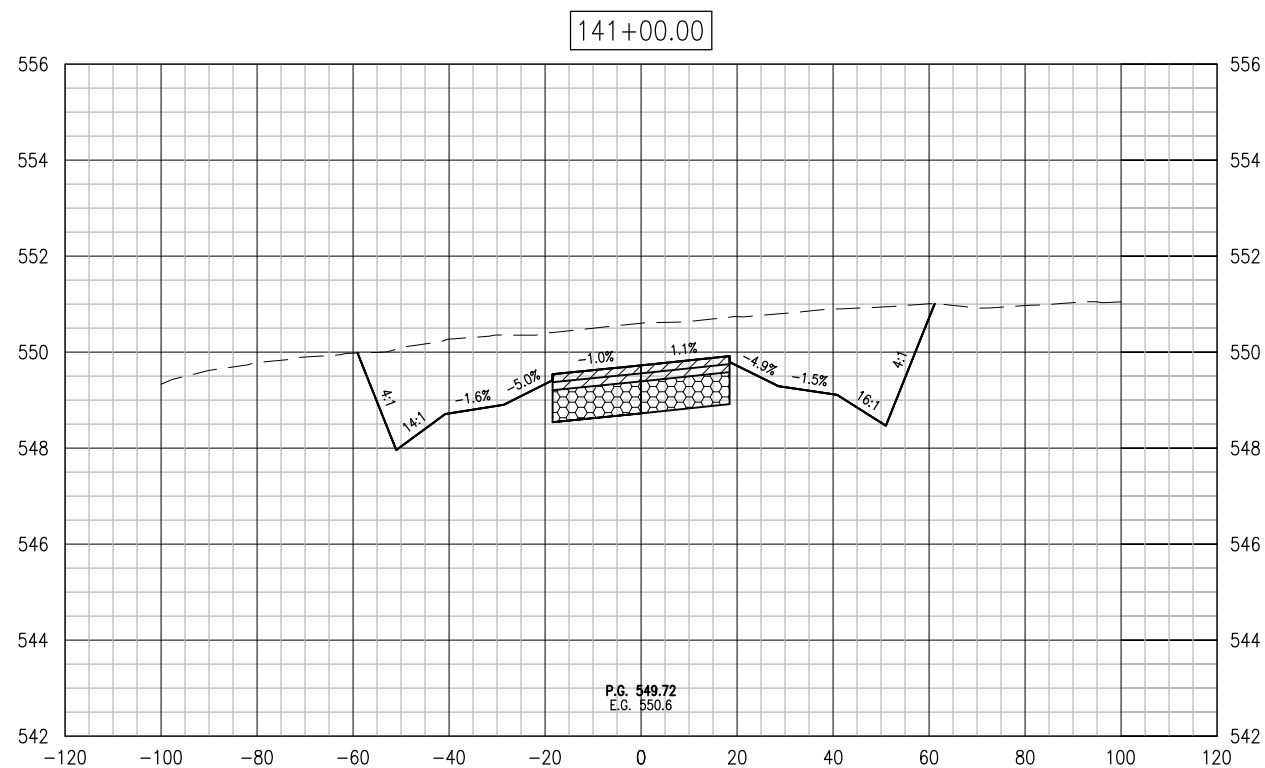
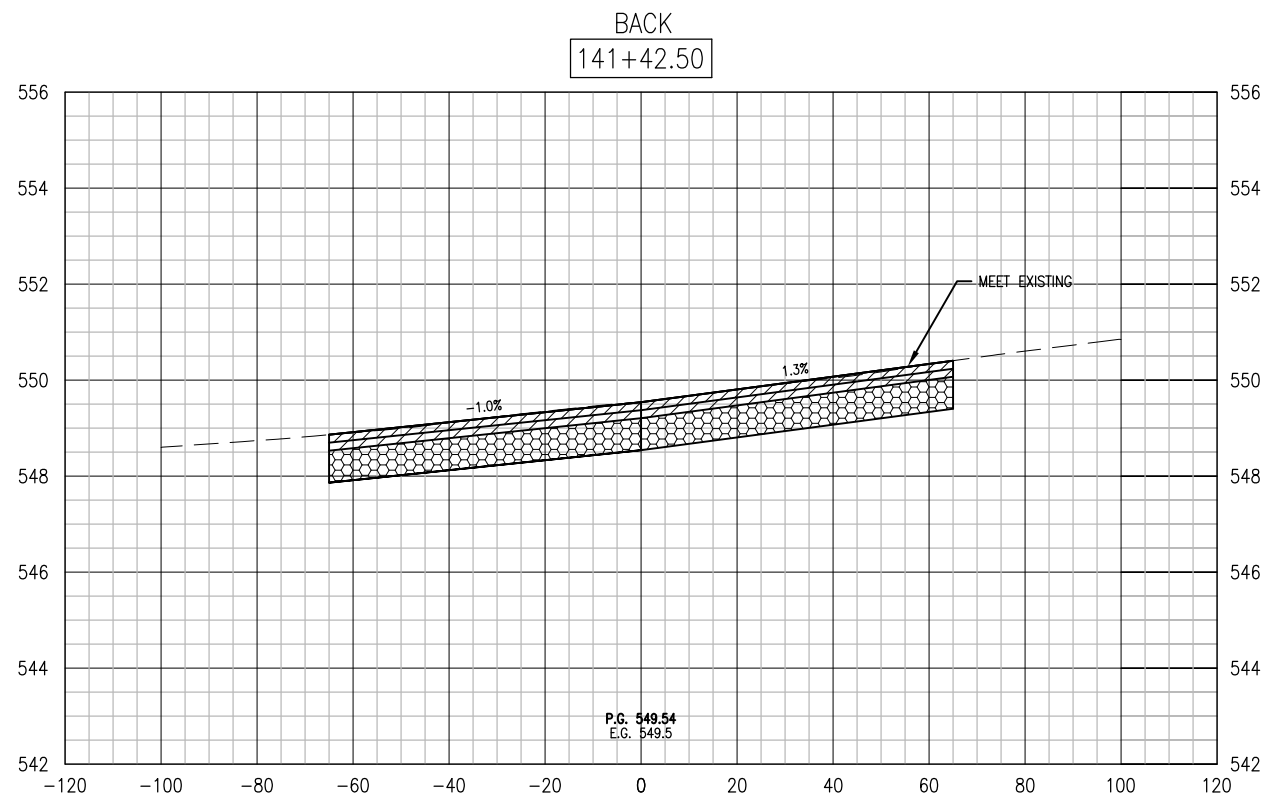

REVISION	DATE

MARSHALL COUNTY AIRPORT
LACON, ILLINOIS

IL PROJ.: C75-4218 BLOCK GRANT: 3-17-0059-B14

Hanson Project No.	09A0031
Filename	C-301-XS.dwg
Scale	1" = 20'H 1" = 2'V
Date	01/11/13
LAYOUT	MLH 12/06/12
DRAWN	MLH 12/06/12
REVIEWED	BSS 01/11/13



CONSTRUCT A 2,065' X 35'
PARTIAL PARALLEL TAXIWAY
TO RUNWAY 13/31

CROSS SECTIONS STA. 141+00
TO STA. 141+42.50

JAN 11, 2013 1:19 PM HARR01115
pw:\sps-svc\06.hanson.dom\hanson_projects\Documents\09A0031\09A0031\CAD\Airport\Sheet\C-301-XS

LEGEND

- EXISTING PAVEMENT
- FUTURE PAVEMENT
- EXISTING ELECTRICAL CABLES
- EXISTING STORM SEWER
- EXISTING UNDERDRAIN
- EXISTING STAKE MOUNTED RUNWAY LIGHT
- EXISTING BASE MOUNTED RUNWAY LIGHT
- EXISTING STAKE MOUNTED RUNWAY THRESHOLD LIGHT
- EXISTING UNDERDRAIN CLEANOUT
- EXISTING PAPI
- EXISTING DUCT MARKER
- EXISTING END SECTION

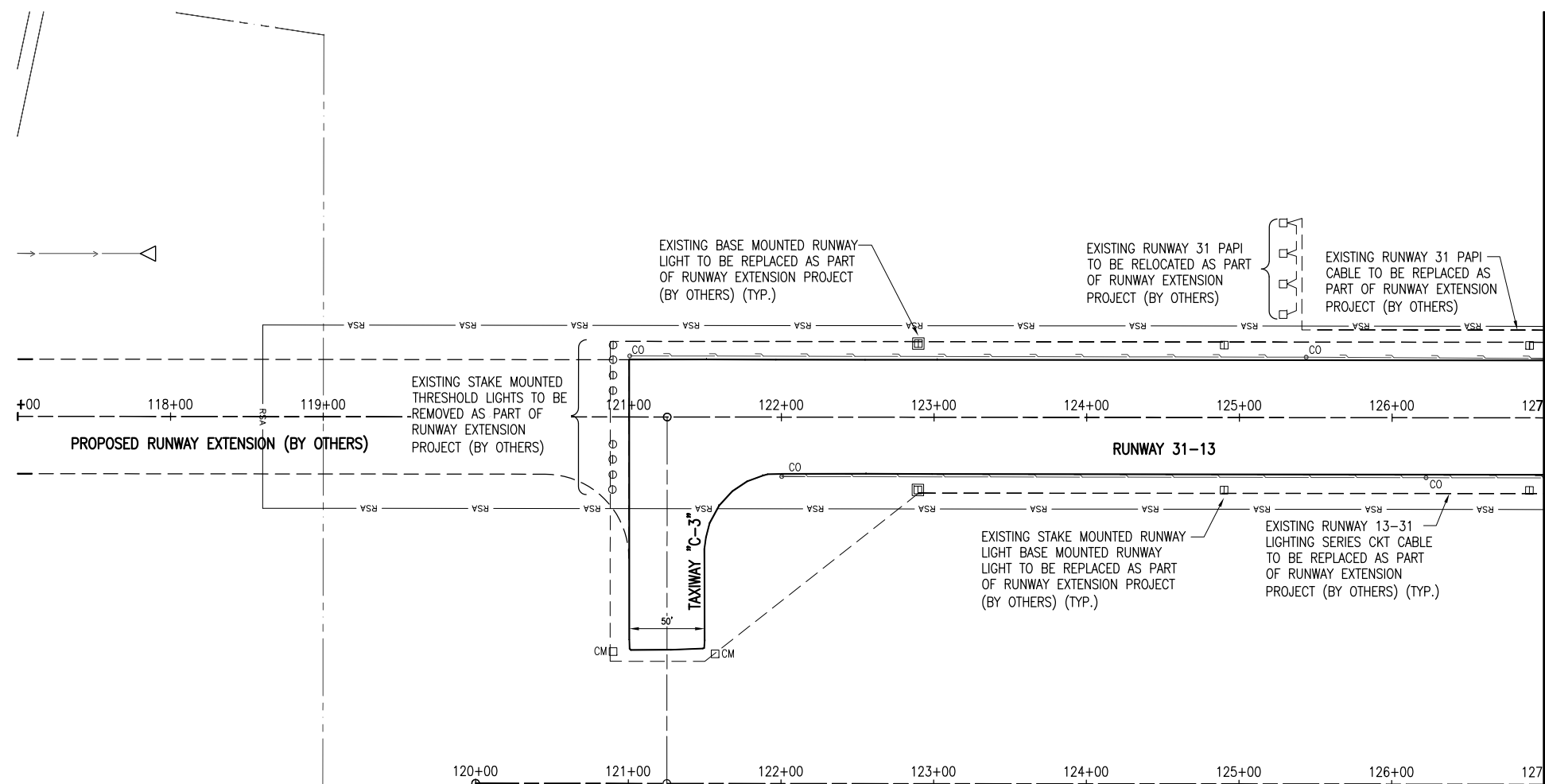

THE LOCATION, SIZE, AND TYPE OF MATERIAL OF EXISTING UNDERGROUND AND/OR ABOVEGROUND UTILITIES INDICATED ON THE PLANS ARE NOT REPRESENTED AS BEING ACCURATE, SUFFICIENT OR COMPLETE. NEITHER THE OWNER NOR THE ENGINEER ASSUMES ANY RESPONSIBILITY WHATEVER IN RESPECT TO THE ACCURACY, COMPLETENESS, OR SUFFICIENCY OF THE INFORMATION. THERE IS NO GUARANTEE, EITHER EXPRESSED OR IMPLIED, THAT THE LOCATIONS, SIZE AND TYPE OF MATERIAL OF EXISTING UNDERGROUND UTILITIES INDICATED ARE REPRESENTATIVE OF THOSE TO BE ENCOUNTERED IN THE CONSTRUCTION. IT SHALL BE THE CONTRACTOR'S RESPONSIBILITY TO DETERMINE THE ACTUAL LOCATION OF ALL SUCH FACILITIES, INCLUDING SERVICE CONNECTIONS TO UNDERGROUND UTILITIES. PRIOR TO CONSTRUCTION, THE CONTRACTOR SHALL NOTIFY THE UTILITY COMPANIES OF HIS OPERATIONAL PLANS AND SHALL OBTAIN FROM THE RESPECTIVE UTILITY COMPANIES DETAILED INFORMATION AND ASSISTANCE RELATIVE TO THE LOCATION OF THEIR FACILITIES AND THE WORKING SCHEDULE OF THE COMPANIES FOR REMOVAL OR ADJUSTMENT WHERE REQUIRED. IN THE EVENT AN UNEXPECTED UTILITY INTERFERENCE IS ENCOUNTERED DURING CONSTRUCTION, THE CONTRACTOR SHALL IMMEDIATELY NOTIFY THE UTILITY COMPANY OF JURISDICTION. THE OWNER'S REPRESENTATIVE AND/OR THE RESIDENT ENGINEER SHALL ALSO BE IMMEDIATELY NOTIFIED. ANY DAMAGE TO SUCH MAINS AND SERVICES SHALL BE RESTORED TO SERVICE AT ONCE AND PAID FOR BY THE CONTRACTOR AT NO ADDITIONAL COST TO THE CONTRACT.

ALL UTILITY CABLES AND LINES SHALL BE LOCATED BY THE RESPECTIVE UTILITY. **CONTACT JULIE (JOINT UTILITY LOCATION INFORMATION FOR EXCAVATORS) FOR UTILITY INFORMATION- PHONE: 1-800-892-0123.** CONTACT THE FAA (FEDERAL AVIATION ADMINISTRATION) FOR ASSISTANCE IN LOCATING FAA CABLES AND UTILITIES. LOCATION OF FAA POWER, CONTROL, AND COMMUNICATION CABLES SHALL BE COORDINATED WITH AND/OR LOCATED BY THE FAA. ALSO CONTACT AIRPORT DIRECTOR/MANAGER AND AIRPORT PERSONNEL FOR ASSISTANCE IN LOCATING UNDERGROUND AIRPORT CABLES AND/OR UTILITIES. ALSO COORDINATE WORK WITH ALL ABOVEGROUND UTILITIES.

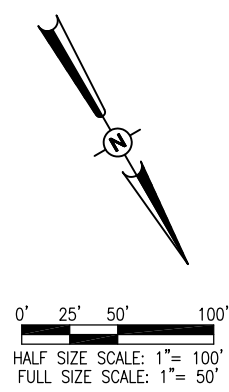

REVISION	DATE

MARSHALL COUNTY AIRPORT
LACON, ILLINOIS

IL PROJ.: C75-4218 BLOCK GRANT: 3-17-0059-B14

Hanson Project No.	09A0031
Filename	C-141-ELE.dwg
Scale	1" = 50'
Date	01/11/13
LAYOUT	KNL 11/11/12
DRAWN	MLH 12/17/12
REVIEWED	BSS 01/11/13













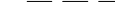





© Copyright Hanson Professional Services Inc. 2013
Hanson Professional Services Inc.
1525 South Main Street
Springfield, Illinois 62703-2886

CONSTRUCT A 2,065' X 35'
PARTIAL PARALLEL TAXIWAY
TO RUNWAY 13/31

EXISTING ELECTRICAL PLAN
STA. 117+00 TO STA. 127+00

JAN 11, 2013 1:19 PM HARR01115
pw:\sps-svr306\hanson.com\hanson Projects\Documents\09\jobs\09A0031\09A0031D\CAD\Airport\Sheet\C-141-ELE

LEGEND

-  EXISTING PAVEMENT
-  EXISTING BUILDINGS
-  EXISTING ELECTRICAL DUCT
-  EXISTING ELECTRICAL CABLES
-  EXISTING STORM SEWER
-  EXISTING UNDERDRAIN
-  EXISTING STAKE MOUNTED RUNWAY LIGHT
-  EXISTING BASE MOUNTED RUNWAY LIGHT
-  EXISTING STAKE MOUNTED TAXIWAY LIGHT
-  EXISTING BASE MOUNTED TAXIWAY LIGHT
-  EXISTING TAXI GUIDANCE SIGN
-  EXISTING WING TEE
-  EXISTING WIND CONE
-  EXISTING ELECTRICAL HANDHOLE
-  EXISTING UNDERDRAIN CLEANOUT
-  EXISTING HEADWALL
-  EXISTING STAKE MOUNTED TAXIWAY LIGHT (TO BE REMOVED)
-  EXISTING BASE MOUNTED TAXIWAY LIGHT (TO BE REMOVED)
-  EXISTING TAXI GUIDANCE SIGN (TO BE REMOVED)

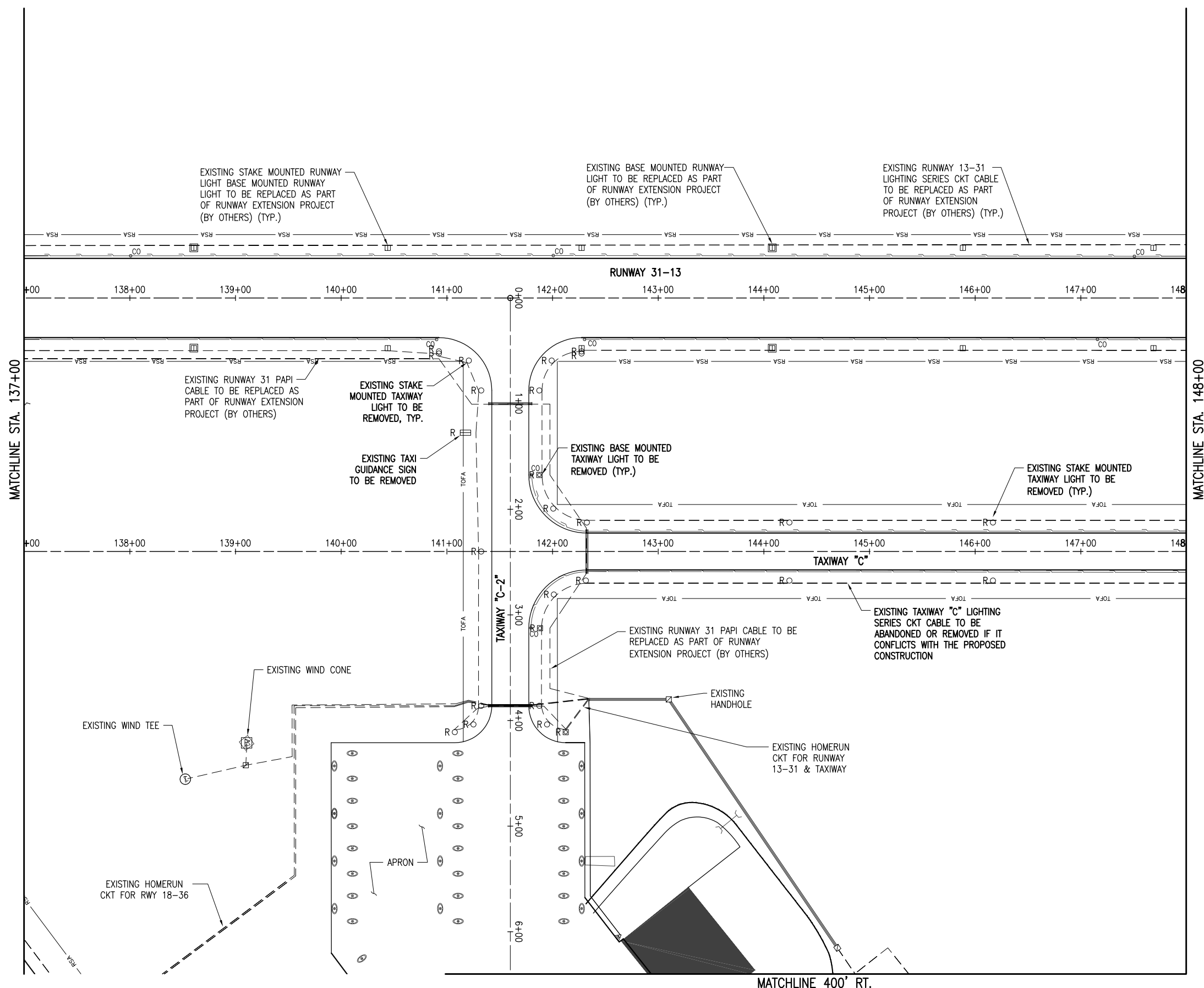

REVISION	DATE

MARSHALL COUNTY AIRPORT
LACON, ILLINOIS

IL PROJ.: C75-4218 BLOCK GRANT: 3-17-0059-B14

Hanson Project No.	09A0031
Filename	C-141-ELE.dwg
Scale	1" = 50'
Date	01/11/13
LAYOUT	KNL 11/11/12
DRAWN	MLH 12/17/12
REVIEWED	BSS 01/11/13



© Copyright Hanson Professional Services Inc. 2013
Hanson Professional Services Inc.
1525 South Lincoln Street
Springfield, Illinois 62703-2886

CONSTRUCT A 2,065' X 35'
HALF SIZE PARALLEL TAXIWAY
TO RUNWAY 13/31

EXISTING ELECTRICAL PLAN
STA. 137+00 TO STA. 148+00

JAN 11, 2013 1:19 PM HARR01115
pw:\sps-sv306\hanson\Documents\09\Jobs\09A0031\09A0031D\CAD\Airport\Sheet\C-141-ELE

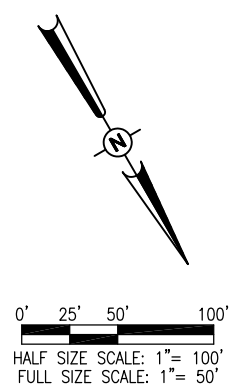

JAN 11, 2013 1:19 PM HARR01115
 pw:\sps-svr306\hanson\Projects\Documents\09\jobs\09A0031\09A0031D\CAD\Airport\Sheet\C-141-ELE

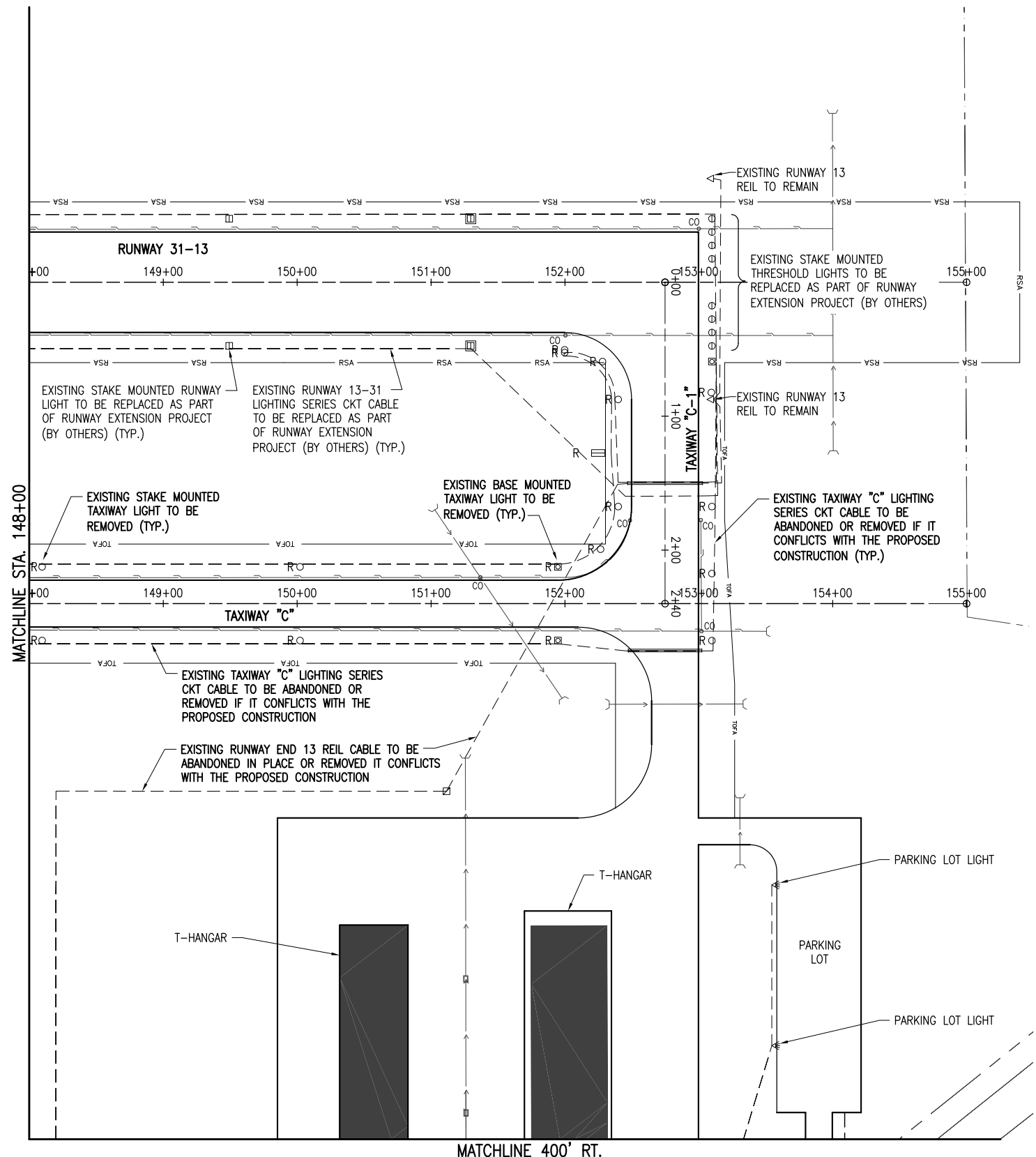

AIRFIELD LIGHTING REMOVAL NOTES

- ALL WORK, POWER OUTAGES, AND/OR SHUT DOWN OF EXISTING SYSTEMS SHALL BE COORDINATED WITH THE AIRPORT DIRECTOR/MANAGER. ONCE SHUT DOWN, THE CIRCUITS SHALL BE LABELED AS SUCH TO PREVENT ACCIDENTAL ENERGIZING OF THE RESPECTIVE CIRCUITS. ALL PERSONNEL SHALL FOLLOW U.S. DEPARTMENT OF LABOR OCCUPATIONAL SAFETY & HEALTH ADMINISTRATION (OSHA) 29 CFR PART 1910 OCCUPATIONAL SAFETY & HEALTH STANDARDS FOR ELECTRICAL SAFETY AND LOCKOUT/TAGOUT PROCEDURES INCLUDING, BUT NOT LIMITED TO, 29 CFR SECTION 1910.147 THE CONTROL OF HAZARDOUS ENERGY (LOCKOUT/TAGOUT).
- CONTRACTOR SHALL EXAMINE THE SITE TO DETERMINE THE EXTENT OF THE WORK. CONTRACTOR SHALL FIELD VERIFY EXISTING SITE CONDITIONS. RUNWAY 13-31 LIGHTING AND THE ASSOCIATED PARALLEL TAXIWAY LIGHTING SYSTEM APPEAR TO BE POWERED BY THE SAME CONSTANT CURRENT REGULATOR. CONTRACTOR SHALL FIELD VERIFY RESPECTIVE CIRCUITS AND POWER SOURCES PRIOR TO REMOVING OR DISCONNECTING THE RESPECTIVE AIRFIELD LIGHTING, NAVAIDS, OR OTHER DEVICE.
- COORDINATE REMOVAL OF TAXIWAY LIGHTS TO MINIMIZE DOWNTIME OF RUNWAY 13-31 LIGHTING SYSTEM. COORDINATE INSTALLATION OF NEW DUCTS AND CABLING TO MINIMIZE DOWNTIME OF RUNWAY 13-31 LIGHTING SYSTEM
- CONTRACTOR SHALL COMPLY WITH THE REQUIREMENTS OF FAA AC NO. 150/5370-2F (OR MOST CURRENT ISSUE) "OPERATIONAL SAFETY ON AIRPORTS DURING CONSTRUCTION".
- CONTRACTOR SHALL COMPLY WITH THE APPLICABLE REQUIREMENTS OF NFPA 70E - STANDARD FOR ELECTRICAL SAFETY IN THE WORKPLACE.
- THE EXISTING AIRFIELD (RUNWAY & TAXIWAY) LIGHTS, TAXI GUIDANCE SIGNS AND THEIR ISOLATED TRANSFORMERS DESIGNATED FOR REMOVAL SHALL BE REMOVED AND TURNED OVER TO THE AIRPORT MANAGER. REMOVAL OF THE EXISTING AIRFIELD LIGHTS WILL BE PAID FOR UNDER ITEM AR125901 REMOVE STAKE MOUNTED LIGHT, PER EACH AND AR125902 REMOVE BASE MOUNTED LIGHT, PER EACH. REMOVAL OF THE TAXI GUIDANCE SIGNS WILL BE PAID FOR UNDER ITEM AR125904 REMOVE TAXI GUIDANCE SIGN PER EACH.
- THE EXISTING AIRFIELD LIGHTING CABLES WILL BE ABANDONED IN PLACE UNLESS IT CONFLICTS WITH THE INSTALLATION OF A PROPOSED LIGHT OR CABLE, PAVEMENT, OR OTHER WORK, THEN IT SHALL BE REMOVED AT NO ADDITIONAL COST TO THE CONTRACT.
- ALL ABOVEGROUND JUMPERS SHALL BE IN A DUCT WITH ALL CONNECTIONS SEALED. THE CONTRACTOR SHALL SECURE, IDENTIFY AND PLACE ALL TEMPORARY EXPOSED WIRING IN CONDUIT, DUCT, OR UNIT DUCT TO PREVENT ELECTROCUTION AND FIRE IGNITION SOURCES AS PER THE REQUIREMENTS OF FAA 150/5370-2F, OPERATIONAL SAFETY ON AIRPORTS DURING CONSTRUCTION, SECTION 218 PARAGRAPH C.
- THE CONTRACTOR IS REQUIRED TO FILL IN ALL HOLES AND DEPRESSIONS RESULTING FROM THE LIGHT AND/OR SIGN REMOVAL WITH EARTH MATERIAL. THE AREAS SHALL BE COMPACTED TO PREVENT FUTURE SETTLEMENT AND FERTILIZED, SEEDED, AND MULCHED IN ACCORDANCE WITH ITEMS 901 AND 908 RESPECTIVELY. THIS WORK SHALL BE CONSIDERED INCIDENTAL TO THE LIGHT REMOVAL AND NO ADDITIONAL COMPENSATION WILL BE ALLOWED.
- NO CONNECTION TO AN ACTIVE LIGHTING CIRCUIT WILL BE BROKEN UNTIL THE CIRCUIT HAS BEEN TURNED OFF IN ACCORDANCE WITH NOTE 1.

LEGEND

- EXISTING PAVEMENT
- EXISTING BUILDINGS
- EXISTING ELECTRICAL DUCT
- EXISTING ELECTRICAL CABLES
- EXISTING STORM SEWER
- EXISTING UNDERDRAIN
- EXISTING STAKE MOUNTED RUNWAY LIGHT
- EXISTING BASE MOUNTED RUNWAY LIGHT
- EXISTING STAKE MOUNTED TAXIWAY LIGHT
- EXISTING BASE MOUNTED TAXIWAY LIGHT
- EXISTING STAKE MOUNTED RUNWAY THRESHOLD LIGHT
- EXISTING REILS
- EXISTING TAXI GUIDANCE SIGN
- EXISTING ELECTRICAL HANDHOLE
- EXISTING UNDERDRAIN CLEANOUT
- EXISTING HEADWALL
- EXISTING STAKE MOUNTED TAXIWAY LIGHT (TO BE REMOVED)
- EXISTING BASE MOUNTED TAXIWAY LIGHT (TO BE REMOVED)
- EXISTING TAXI GUIDANCE SIGN (TO BE REMOVED)

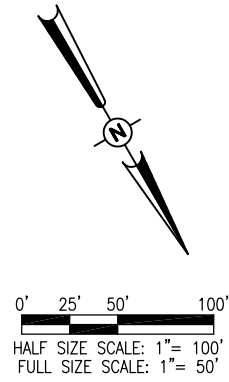

MA026

REVISION	DATE

MARSHALL COUNTY AIRPORT
 LACON, ILLINOIS

IL PROJ.: C75-4218 BLOCK GRANT: 3-17-0059-B14

Hanson Project No.	09A0031
Filename	C-141-ELE.dwg
Scale	1" = 50'
Date	01/11/13
LAYOUT	KNL 11/11/12
DRAWN	MLH 12/17/12
REVIEWED	BSS 01/11/13



© Copyright Hanson Professional Services Inc. 2013
 Hanson Professional Services Inc.
 1525 South Main Street
 Springfield, Illinois 62703-2886

CONSTRUCT A 2,065' X 35'
 PARTIAL PARALLEL TAXIWAY
 TO RUNWAY 13/31
 EXISTING ELECTRICAL PLAN
 STA. 148+00 TO STA. 153+00

45

MATCHLINE 400' RT.

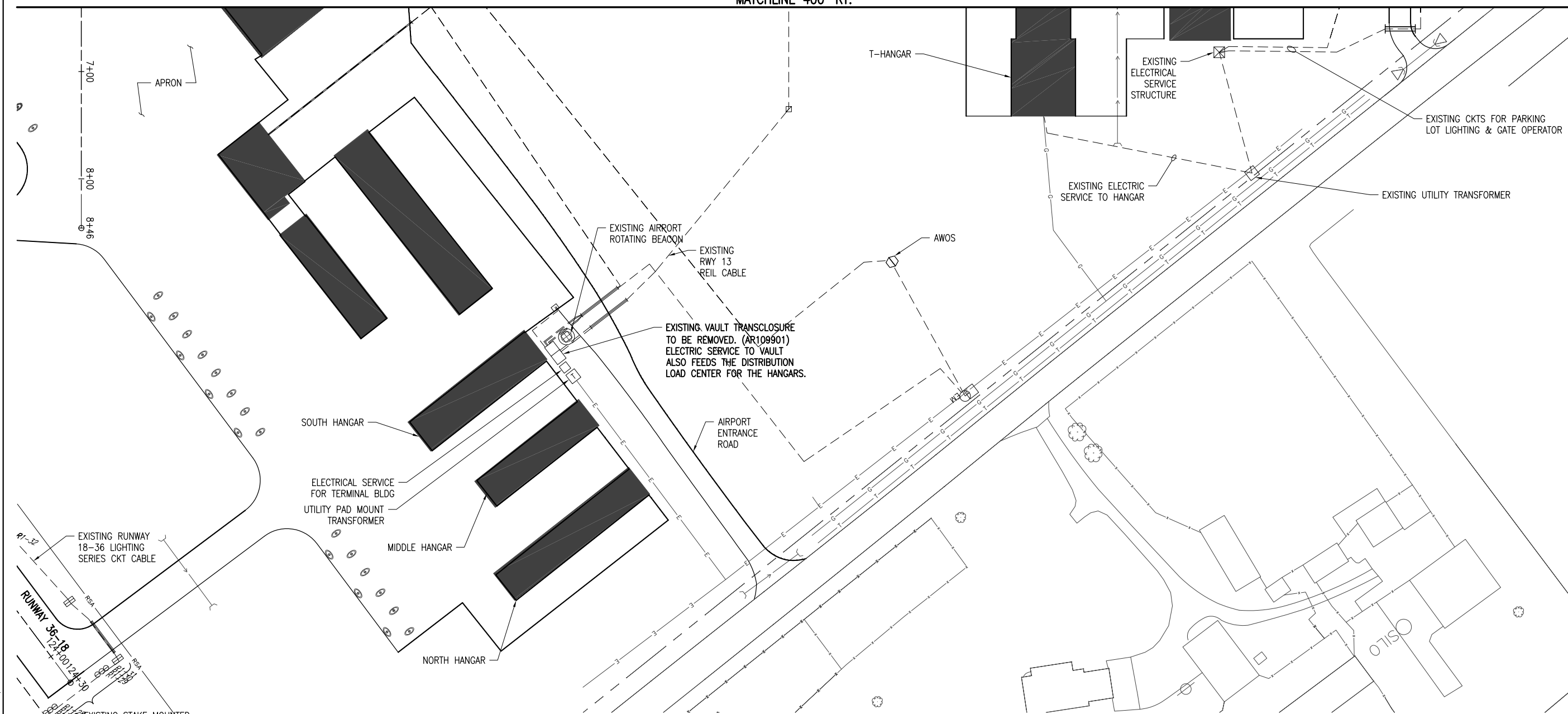

THE LOCATION, SIZE, AND TYPE OF MATERIAL OF EXISTING UNDERGROUND AND/OR ABOVEGROUND UTILITIES INDICATED ON THE PLANS ARE NOT REPRESENTED AS BEING ACCURATE, SUFFICIENT OR COMPLETE. NEITHER THE OWNER NOR THE ENGINEER ASSUMES ANY RESPONSIBILITY WHATEVER IN RESPECT TO THE ACCURACY, COMPLETENESS, OR SUFFICIENCY OF THE INFORMATION. THERE IS NO GUARANTEE, EITHER EXPRESSED OR IMPLIED, THAT THE LOCATIONS, SIZE AND TYPE OF MATERIAL OF EXISTING UNDERGROUND UTILITIES INDICATED ARE REPRESENTATIVE OF THOSE TO BE ENCOUNTERED IN THE CONSTRUCTION. IT SHALL BE THE CONTRACTOR'S RESPONSIBILITY TO DETERMINE THE ACTUAL LOCATION OF ALL SUCH FACILITIES, INCLUDING SERVICE CONNECTIONS TO UNDERGROUND UTILITIES. PRIOR TO CONSTRUCTION, THE CONTRACTOR SHALL NOTIFY THE UTILITY COMPANIES OF HIS OPERATIONAL PLANS AND SHALL OBTAIN FROM THE RESPECTIVE UTILITY COMPANIES DETAILED INFORMATION AND ASSISTANCE RELATIVE TO THE LOCATION OF THEIR FACILITIES AND THE WORKING SCHEDULE OF THE COMPANIES FOR REMOVAL OR ADJUSTMENT WHERE REQUIRED. IN THE EVENT AN UNEXPECTED UTILITY INTERFERENCE IS ENCOUNTERED DURING CONSTRUCTION, THE CONTRACTOR SHALL IMMEDIATELY NOTIFY THE UTILITY COMPANY OF JURISDICTION. THE OWNER'S REPRESENTATIVE AND/OR THE RESIDENT ENGINEER SHALL ALSO BE IMMEDIATELY NOTIFIED. ANY DAMAGE TO SUCH MAINS AND SERVICES SHALL BE RESTORED TO SERVICE AT ONCE AND PAID FOR BY THE CONTRACTOR AT NO ADDITIONAL COST TO THE CONTRACT.

ALL UTILITY CABLES AND LINES SHALL BE LOCATED BY THE RESPECTIVE UTILITY. CONTACT JULIE (JOINT UTILITY LOCATION INFORMATION FOR EXCAVATORS) FOR UTILITY INFORMATION, PHONE: 1-800-892-0123. CONTACT THE FAA (FEDERAL AVIATION ADMINISTRATION) FOR ASSISTANCE IN LOCATING FAA CABLES AND UTILITIES. LOCATION OF FAA POWER, CONTROL, AND COMMUNICATION CABLES SHALL BE COORDINATED WITH AND/OR LOCATED BY THE FAA. ALSO CONTACT AIRPORT DIRECTOR/MANAGER AND AIRPORT PERSONNEL FOR ASSISTANCE IN LOCATING UNDERGROUND AIRPORT CABLES AND/OR UTILITIES. ALSO COORDINATE WORK WITH ALL ABOVEGROUND UTILITIES.

- LEGEND**
- EXISTING PAVEMENT
 - EXISTING BUILDINGS
 - EXISTING ELECTRICAL DUCT
 - EXISTING ELECTRICAL CABLES
 - EXISTING STORM SEWER
 - EXISTING STAKE MOUNTED RUNWAY LIGHT
 - EXISTING BASE MOUNTED RUNWAY LIGHT
 - EXISTING STAKE MOUNTED TAXIWAY LIGHT
 - EXISTING BASE MOUNTED TAXIWAY LIGHT
 - EXISTING STAKE MOUNTED RUNWAY THRESHOLD LIGHT
 - EXISTING TAXI GUIDANCE SIGN
 - EXISTING HEADWALL
 - EXISTING GAS
 - EXISTING TELEPHONE
 - EXISTING ELECTRIC
 - EXISTING FENCE

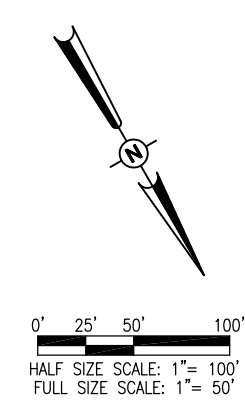

JAN 11, 2013 1:19 PM HARR01115
 pw:\sps-sv306\hanson.dom\hanson_projects\Documents\09\jobs\09A0031\09A0031D\CAD\Airport\Sheet\C-141-ELE

REVISION	DATE

MARSHALL COUNTY AIRPORT
 LACON, ILLINOIS
 IL PROJ.: C75-4218 BLOCK GRANT: 3-17-0059-B14

Hanson Project No.	Filename	Scale	Date	LAYOUT	KNL	11/11/12
09A0031	C-141-ELE.dwg	1" = 50'	01/11/13	DRAWN	MLH	12/17/12
				REVIEWED	BSS	01/11/13



CONSTRUCT A 2,065' X 35'
 PARTIAL PARALLEL TAXIWAY
 TO RUNWAY 13/31
 EXISTING ELECTRICAL PLAN
 400' RT.

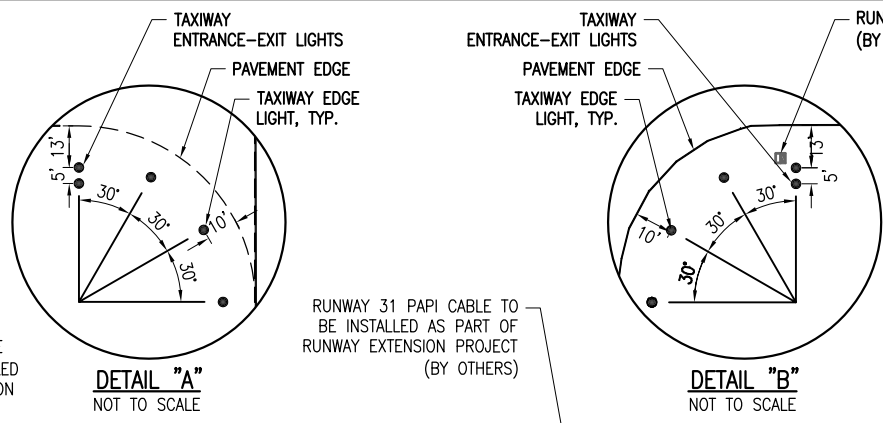
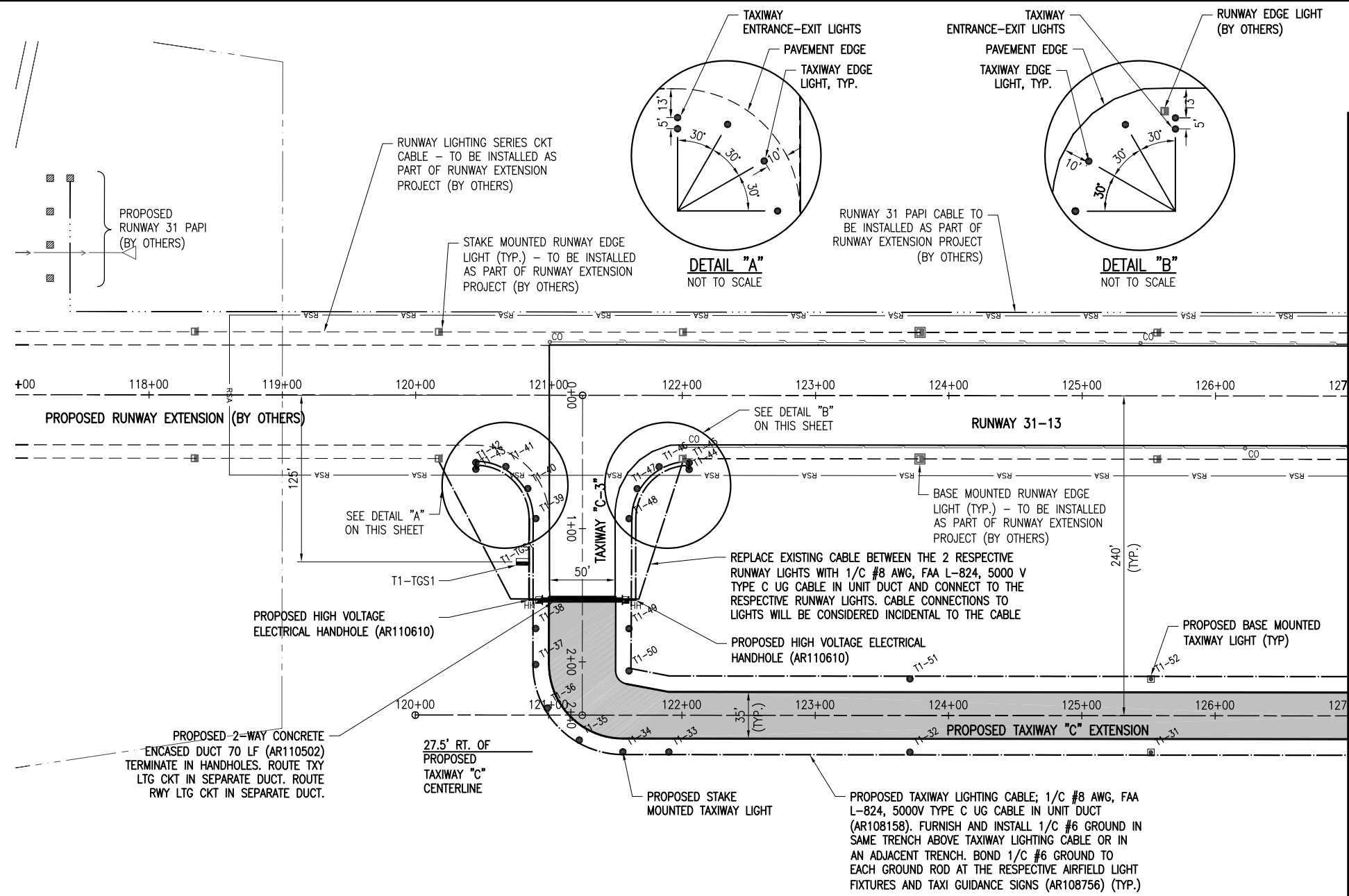

LEGEND

	EXISTING PAVEMENT
	PROPOSED PAVEMENT
	FUTURE PAVEMENT
	EXISTING ELECTRICAL DUCT
	PROPOSED ELECTRICAL DUCT
	EXISTING ELECTRICAL CABLES
	PROPOSED 1/C #8 AWG, FAA L-824, 5000 VOLT TYPE C UNDERGROUND CABLE IN UNIT DUCT
	PROPOSED 2-1/C #8 AWG, FAA L-824, 5000 VOLT TYPE C UNDERGROUND CABLE IN UNIT DUCT
	PROPOSED 3-1/C #6 XLP-USE 600V UG CABLE IN UNIT DUCT
	EXISTING STORM SEWER
	EXISTING UNDERDRAIN
	EXISTING UNDERDRAIN CLEANOUT
	EXISTING END SECTION
	EXISTING STAKE MOUNTED RUNWAY LIGHT
	EXISTING BASE MOUNTED RUNWAY LIGHT
	EXISTING STAKE MOUNTED RUNWAY THRESHOLD LIGHT
	EXISTING PAPI
	EXISTING DUCT MARKER
	PROPOSED STAKE MOUNTED TAXIWAY LIGHT
	PROPOSED BASE MOUNTED TAXIWAY LIGHT
	PROPOSED TAXI GUIDANCE SIGN
	PROPOSED ELECTRICAL HANDHOLE
	PROPOSED ELECTRICAL MANHOLE

REVISION	
DATE	
MARSHALL COUNTY AIRPORT LACON, ILLINOIS	
BLOCK GRANT: 3-17-0059-B14	
IL PROJ.: C75-4218	

Hanson Project No.	09A0031
Filename	C-142-ELEC.dwg
Scale	1" = 50'
Date	01/11/13
LAYOUT	KNL/MLH 11/18/12
DRAWN	MLH/TRR 12/18/12
REVIEWED	BSS 01/11/13

HANSON
 Copyright Hanson Professional Services Inc. 2013
 Hanson Professional Services Inc.
 1425 South Main Street
 Springfield, Illinois 62703-2886

CONSTRUCT A 2,065' X 35'
 PARTIAL PARALLEL TAXIWAY
 TO RUNWAY 13/31
 PROPOSED ELECTRICAL PLAN
 STA. 117+00 TO STA. 127+00

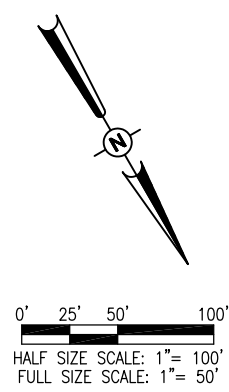

AIRFIELD LIGHTING NOTES

- ALL WORK, POWER OUTAGES, AND/OR SHUT DOWN OF EXISTING SYSTEMS SHALL BE COORDINATED WITH THE AIRPORT MANAGER. ONCE SHUT DOWN, THE CIRCUITS SHALL BE LABELED AS SUCH TO PREVENT ACCIDENTAL ENERGIZING OF THE RESPECTIVE CIRCUITS. ALL PERSONNEL SHALL FOLLOW U.S. DEPARTMENT OF LABOR OCCUPATIONAL SAFETY & HEALTH ADMINISTRATION (OSHA) 29 CFR PART 1910 OCCUPATIONAL SAFETY & HEALTH STANDARDS FOR ELECTRICAL SAFETY AND LOCKOUT/TAGOUT PROCEDURES INCLUDING, BUT NOT LIMITED TO 29 CFR SECTION 1910.147 THE CONTROL OF HAZARDOUS ENERGY (LOCKOUT/TAGOUT).
- CONTRACTOR SHALL FIELD VERIFY EXISTING SITE CONDITIONS. CONTRACTOR SHALL FIELD VERIFY RESPECTIVE CIRCUITS AND POWER SOURCES PRIOR TO REMOVING OR DISCONNECTING THE RESPECTIVE AIRFIELD LIGHTING, NAVAID, OR OTHER DEVICE.
- PROPOSED TAXIWAY LIGHTS SHALL BE PLACED 10' (FT.) FROM THE PAVEMENT EDGE UNLESS SHOWN OTHERWISE ON THESE CONSTRUCTION DRAWINGS. PROPOSED TAXI GUIDANCE SIGNS SHALL BE LOCATED SUCH THAT THE CLOSEST SIDE OF THE SIGN IS 15' FROM THE PAVEMENT EDGE, UNLESS SHOWN OTHERWISE.
- PROPOSED TAXIWAY LIGHTS, GUIDANCE SIGNS, OTHER AIRFIELD LIGHTING, SPLICE CANS, HANDHOLES, MANHOLES, ELECTRICAL DUCTS, AND CABLE SHALL BE INSTALLED AT THE LOCATIONS SHOWN AND IN COMPLIANCE WITH THE SPECIFICATIONS, SPECIAL PROVISIONS, RESPECTIVE DETAILS, AND MANUFACTURER'S RECOMMENDATIONS.
- PROPOSED CABLE FOR RUNWAY AND TAXIWAY LIGHTING SHALL BE INSTALLED APPROXIMATELY 10' FROM THE PAVEMENT EDGE. CABLES SHALL BE PLACED A MINIMUM OF 18" BELOW FINISHED GRADE.
- THE PROPOSED RUNWAY AND TAXIWAY LIGHTING CABLE SHALL BE 1/C, #8 AWG, FAA L-824, 5000 VOLT, TYPE C UNDERGROUND CABLE IN UNIT DUCT (AR108158), OR DUCT AS DETAILED HEREIN. THE PROPOSED RUNWAY AND TAXIWAY LIGHTING HOMERUN CABLES SHALL BE 2-1/C #8 AWG, FAA L-824, 5000 VOLT TYPE C UNDERGROUND CABLES IN UNIT DUCT (AR108258).
- IN AREAS WHERE THERE IS A CONGESTION OF CABLES OR WHERE THE PROPOSED CABLE CROSSES AN EXISTING CABLE, THE CONTRACTOR IS REQUIRED TO HAND DIG THE TRENCH NECESSARY FOR THE PROPOSED CABLE. AT OTHER LOCATIONS, THE PROPOSED CABLE MAY BE TRENCHED OR PLOWED INTO PLACE. HAND DIGGING, TRENCHING AND/OR PLOWING WILL BE CONSIDERED INCIDENTAL TO THE PROPOSED CABLES AND NO ADDITIONAL COMPENSATION WILL BE ALLOWED.
- ALL PROPOSED TAXIWAY LIGHTS SHALL BE L-861T(L) WITH LED (LIGHT EMITTING DIODE) ILLUMINATION AND FITTED WITH 360° BLUE LENSES.
- ALL PROPOSED TAXIWAY LIGHTS SHALL BE TAGGED BY THE CONTRACTOR IN ACCORDANCE WITH THE LIGHT NUMBERS SHOWN ON THESE CONSTRUCTION DRAWINGS.
- SEE "TAXI GUIDANCE SIGN SCHEDULE" FOR INFO ON SIGN LEGENDS.
- THE CONTRACTOR SHALL SECURE, IDENTIFY AND PLACE ALL TEMPORARY EXPOSED WIRING IN CONDUIT, DUCT OR UNIT DUCT TO PREVENT ELECTROCUTION AND FIRE IGNITION SOURCES AS PER THE REQUIREMENTS OF FAA AC 150/5370-2F, PART 218, PARAGRAPH C. ALL LABOR, MATERIALS, AND TIME NECESSARY TO COMPLY WITH THIS REQUIREMENT SHALL BE CONSIDERED INCIDENTAL TO THE CONTRACT AND NO ADDITIONAL COMPENSATION WILL BE ALLOWED.
- HOMERUN CABLES FOR A RESPECTIVE CIRCUIT THAT ARE INSTALLED IN CONDUIT OR DUCT SHALL BE RUN TOGETHER IN THE SAME RACEWAY OR DUCT.
- EXISTING AIRFIELD LIGHTING CABLES IN AREAS OF NEW WORK SHALL BE DISCONNECTED & REMOVED WHERE IN CONFLICT WITH NEW CONSTRUCTION. IN OTHER AREAS CABLES MAY BE ABANDONED IN PLACE.
- THE CONTRACTOR IS REQUIRED TO FILL IN ALL HOLES AND DEPRESSIONS RESULTING FROM THE NEW WORK, WITH EARTH MATERIAL. THE AREAS SHALL BE COMPACTED TO PREVENT FUTURE SETTLEMENT AND FERTILIZED, SEEDED, AND MULCHED IN ACCORDANCE WITH ITEMS 901 AND 908 RESPECTIVELY. THIS WORK WILL BE CONSIDERED AS AN INCIDENTAL ITEM AND NO ADDITIONAL COMPENSATION WILL BE ALLOWED.
- FURNISH AND INSTALL A #6 AWG BARE SOLID COPPER GROUND AND BOND IT TO EACH GROUND ROD AT THE RESPECTIVE AIRFIELD LIGHT FIXTURES AND TAXI GUIDANCE SIGNS. THE #6 AWG GROUND SHALL BE DIRECT BURIAL IN TRENCH APPROXIMATELY 12 TO 18 IN. BELOW GRADE. THE GROUND CONDUCTOR MAY BE INSTALLED ABOVE THE #8 FAA L-824, 5,000-VOLT CABLE IN UNIT DUCT OR IN AN ADJACENT TRENCH. THE #6 AWG GROUND SHALL BE CONNECTED TO EACH RESPECTIVE GROUND ROD WITH AN EXOTHERMIC WELD CONNECTION. THE COMPLETED GROUND WIRE INSTALLED WILL PROVIDE A GROUND RING SYSTEM FOR THE RESPECTIVE AIRFIELD LIGHTING CIRCUIT. THE GROUND WIRE WILL NOT BE INSTALLED WITH THE HOMERUN CABLES FOR THE RESPECTIVE AIRFIELD LIGHTING CIRCUIT. THE #6 AWG BARE SOLID COPPER GROUND WILL BE PAID FOR UNDER ITEM AR108756 1/C #6 GROUND PER LINEAL FOOT.
- IN THE EVENT THAT OTHER CONSTRUCTION PROJECTS ARE IN PROGRESS AT THE AIRPORT AT THE SAME TIME AS THIS PROJECT, THE CONTRACTOR WILL BE REQUIRED TO COOPERATE WITH ALL OTHER CONTRACTORS AND THE AIRPORT MANAGER IN COORDINATION OF THE WORK.
- NO CONNECTION TO AN ACTIVE LIGHTING CIRCUIT WILL BE BROKEN UNTIL THE CIRCUIT HAS BEEN TURNED OFF IN ACCORDANCE WITH NOTE 1.

JAN 11, 2013 1:19 PM HARR01115
 p:\s\svr306\hanson\Projects\Documents\09\jobs\09A0031\09A0031D\CAD\Airport\Sheet\C-142-ELEC

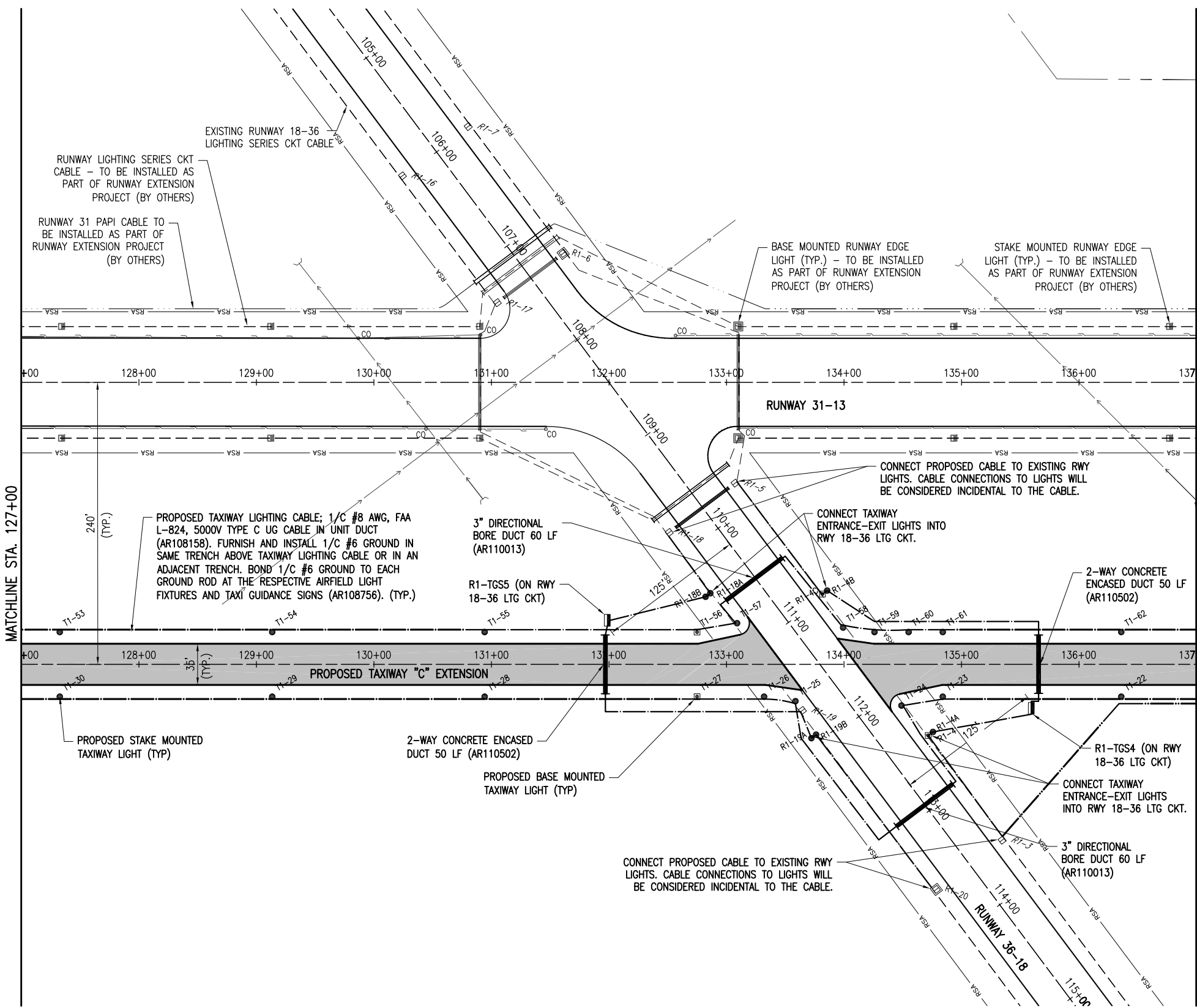

- LEGEND**
- EXISTING PAVEMENT
 - PROPOSED PAVEMENT
 - FUTURE PAVEMENT
 - EXISTING ELECTRICAL DUCT
 - PROPOSED ELECTRICAL DUCT
 - EXISTING ELECTRICAL CABLES
 - PROPOSED 1/C #8 AWG, FAA L-824, 5000 VOLT TYPE C UNDERGROUND CABLE IN UNIT DUCT
 - PROPOSED 2-1/C #8 AWG, FAA L-824, 5000 VOLT TYPE C UNDERGROUND CABLE IN UNIT DUCT
 - PROPOSED 3-1/C #6 XLP-USE 600V UG CABLE IN UNIT DUCT
 - EXISTING STORM SEWER
 - EXISTING UNDERDRAIN
 - EXISTING UNDERDRAIN CLEANOUT
 - EXISTING END SECTION
 - EXISTING STAKE MOUNTED RUNWAY LIGHT
 - EXISTING BASE MOUNTED RUNWAY LIGHT
 - EXISTING STAKE MOUNTED RUNWAY THRESHOLD LIGHT
 - EXISTING PAPI
 - EXISTING DUCT MARKER
 - PROPOSED STAKE MOUNTED TAXIWAY LIGHT
 - PROPOSED BASE MOUNTED TAXIWAY LIGHT
 - PROPOSED TAXI GUIDANCE SIGN
 - PROPOSED ELECTRICAL HANDHOLE
 - PROPOSED ELECTRICAL MANHOLE

REVISION	DATE

MARSHALL COUNTY AIRPORT
LACON, ILLINOIS

IL PROJ.: C75-4218 BLOCK GRANT: 3-17-0059-B14

Hanson Project No.	09A0031
Filename	C-142-ELEC.dwg
Scale	1" = 50'
Date	01/11/13
LAYOUT	KNL/MLH 11/18/12
DRAWN	MLH/TRR 12/18/12
REVIEWED	BSS 01/11/13

HANSON

© Copyright Hanson Professional Services Inc. 2013
Hanson Professional Services Inc.
1525 South Main Street
Springfield, Illinois 62703-2886

CONSTRUCT A 2,065' X 35'
PARTIAL PARALLEL TAXIWAY
TO RUNWAY 13/31

PROPOSED ELECTRICAL PLAN
STA. 127+00 TO STA. 137+00

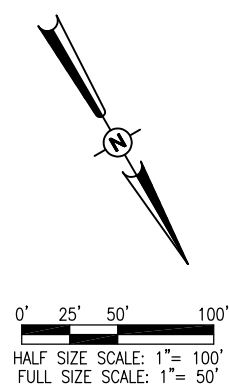

JAN 11, 2013 1:19 PM HARR01115
pw:\s\sp\svr306\hanson\dom\hanson_projects\Documents\09\obs\09A0031\09A0031D\CAD\Airport\Sheet\C-142-ELEC

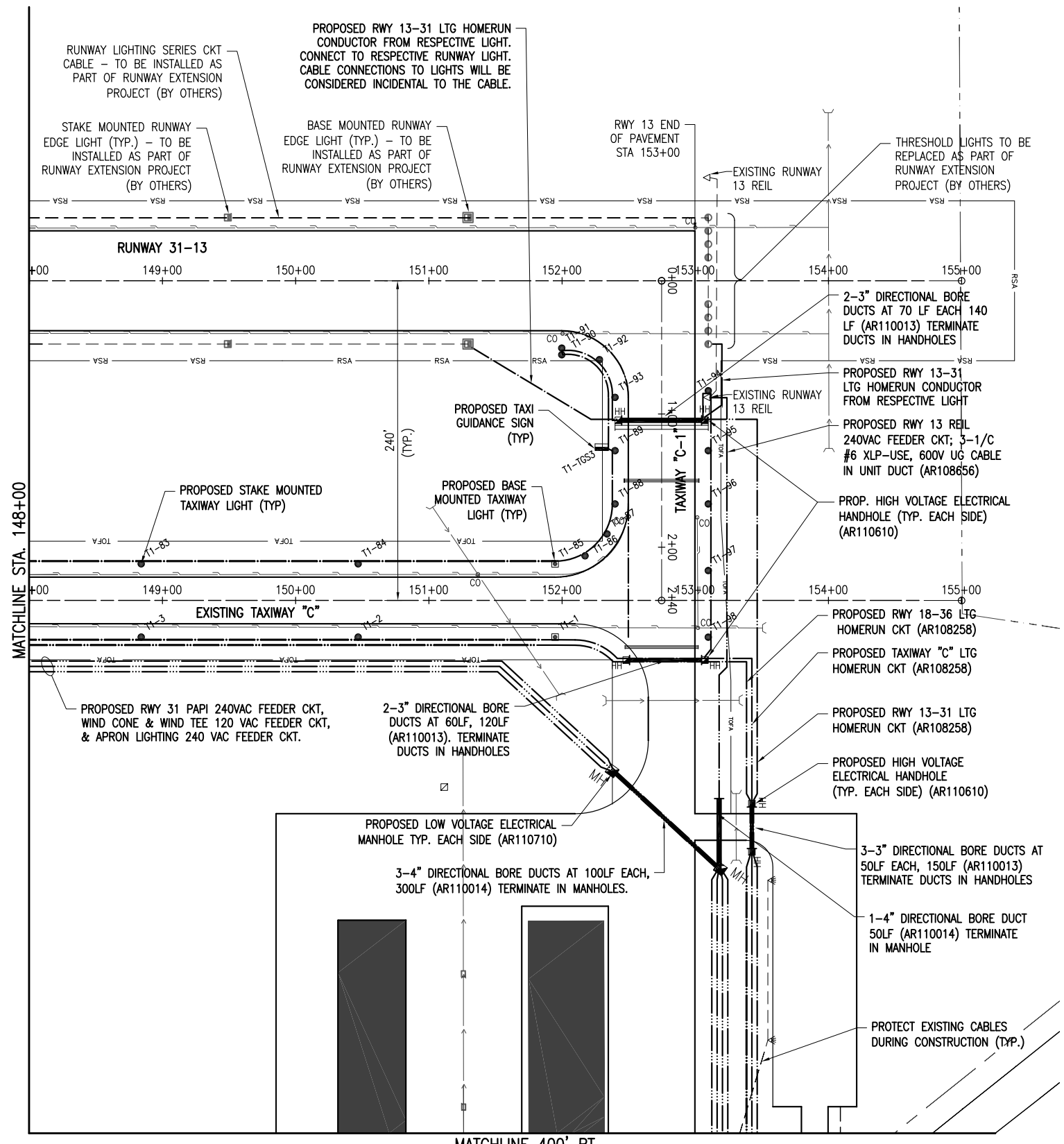

- LEGEND**
- [Solid Line] EXISTING PAVEMENT
 - [Shaded Area] PROPOSED PAVEMENT
 - [Dashed Line] FUTURE PAVEMENT
 - [Double Line] EXISTING ELECTRICAL DUCT
 - [Thick Solid Line] PROPOSED ELECTRICAL DUCT
 - [Thin Dashed Line] EXISTING ELECTRICAL CABLES
 - [Thin Solid Line] PROPOSED 1/C #8 AWG, FAA L-824, 5000 VOLT TYPE C UNDERGROUND CABLE IN UNIT DUCT
 - [Thin Solid Line] PROPOSED 2-1/C #8 AWG, FAA L-824, 5000 VOLT TYPE C UNDERGROUND CABLE IN UNIT DUCT
 - [Thin Solid Line] PROPOSED 3-1/C #6 XLP-USE 600V UG CABLE IN UNIT DUCT
 - [Arrow] EXISTING STORM SEWER
 - [Line] EXISTING UNDERDRAIN
 - [Circle with Center] EXISTING UNDERDRAIN CLEANOUT
 - [Triangle] EXISTING CULVERT END SECTION
 - [Square with Center] EXISTING STAKE MOUNTED RUNWAY LIGHT
 - [Square with Center] EXISTING BASE MOUNTED RUNWAY LIGHT
 - [Circle with Center] EXISTING STAKE MOUNTED RUNWAY THRESHOLD LIGHT
 - [Square] EXISTING PAPI
 - [Square with Center] EXISTING DUCT MARKER
 - [Circle with Center] PROPOSED STAKE MOUNTED TAXIWAY LIGHT
 - [Square with Center] PROPOSED BASE MOUNTED TAXIWAY LIGHT
 - [Square] PROPOSED TAXI GUIDANCE SIGN
 - [Square with Center] PROPOSED ELECTRICAL HANDHOLE
 - [Square with Center] PROPOSED ELECTRICAL MANHOLE
 - [Triangle] EXISTING REIL

- NOTES**
- ADJUST DUCT LOCATIONS WHERE APPLICABLE TO AVOID INTERFERENCES WITH EXISTING UTILITIES, UNDERDRAINS, PIPES, STRUCTURES, CABLES, OR OTHER INSTALLATIONS.

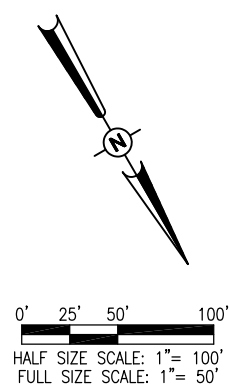

REVISION	DATE

MARSHALL COUNTY AIRPORT
LACON, ILLINOIS

IL PROJ.: C75-4218 BLOCK GRANT: 3-17-0059-B14

Hanson Project No.	09A0031
Filename	C-142-ELEC.dwg
Scale	1" = 50'
Date	01/11/13
LAYOUT	BAK 08/07/12
DRAWN	BAK 08/07/12
REVIEWED	BSS 01/11/13



CONSTRUCT A 2,065' X 35' PARTIAL PARALLEL TAXIWAY TO RUNWAY 13/31

PROPOSED ELECTRICAL PLAN STA. 148+00 TO STA. 153+00

JAN 11, 2013 1:19 PM HARR01115
p:\s\svr306\hanson\Documents\09A0031\09A0031D\CAD\Airport\Sheet\C-142-ELEC

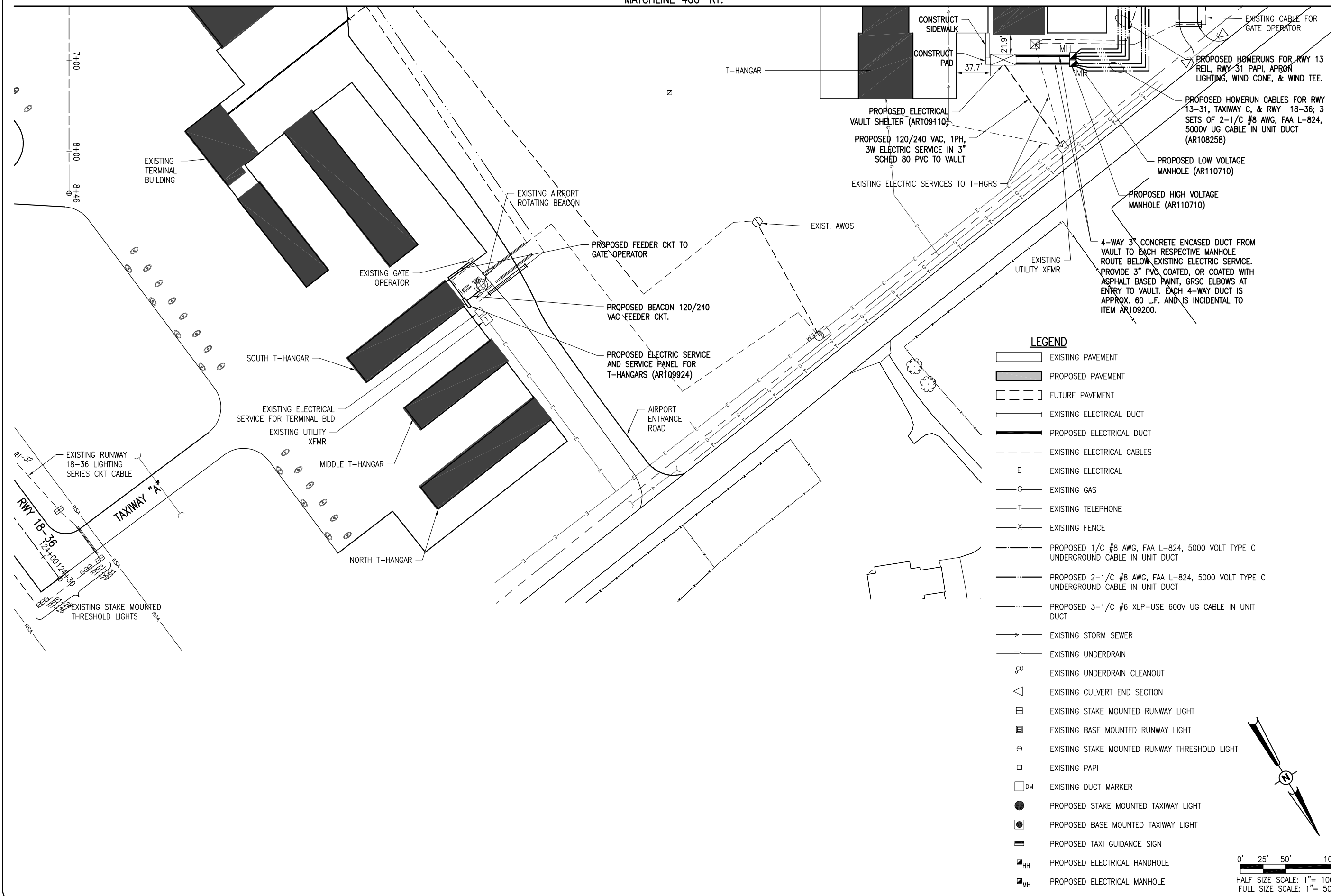

- LEGEND**
- EXISTING PAVEMENT
 - PROPOSED PAVEMENT
 - FUTURE PAVEMENT
 - EXISTING ELECTRICAL DUCT
 - PROPOSED ELECTRICAL DUCT
 - EXISTING ELECTRICAL CABLES
 - EXISTING ELECTRICAL
 - EXISTING GAS
 - EXISTING TELEPHONE
 - EXISTING FENCE
 - PROPOSED 1/C #8 AWG, FAA L-824, 5000 VOLT TYPE C UNDERGROUND CABLE IN UNIT DUCT
 - PROPOSED 2-1/C #8 AWG, FAA L-824, 5000 VOLT TYPE C UNDERGROUND CABLE IN UNIT DUCT
 - PROPOSED 3-1/C #6 XLP-USE 600V UG CABLE IN UNIT DUCT
 - EXISTING STORM SEWER
 - EXISTING UNDERDRAIN
 - EXISTING UNDERDRAIN CLEANOUT
 - EXISTING CULVERT END SECTION
 - EXISTING STAKE MOUNTED RUNWAY LIGHT
 - EXISTING BASE MOUNTED RUNWAY LIGHT
 - EXISTING STAKE MOUNTED RUNWAY THRESHOLD LIGHT
 - EXISTING PAPI
 - EXISTING DUCT MARKER
 - PROPOSED STAKE MOUNTED TAXIWAY LIGHT
 - PROPOSED BASE MOUNTED TAXIWAY LIGHT
 - PROPOSED TAXI GUIDANCE SIGN
 - PROPOSED ELECTRICAL HANDHOLE
 - PROPOSED ELECTRICAL MANHOLE

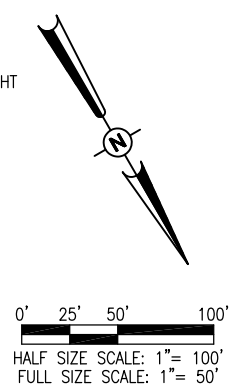

REVISION	DATE

MARSHALL COUNTY AIRPORT
LACON, ILLINOIS

IL PROJ.: C75-4218 BLOCK GRANT: 3-17-0059-B14

Hanson Project No.	09A0031
Filename	C-142-ELEC.dwg
Scale	1" = 50'
Date	01/11/13

LAYOUT	KNL/MLH	11/18/12
DRAWN	MLH/TRR	12/18/12
REVIEWED	BSS	01/11/13

HANSON
Professional Services Inc.
1525 S. 36th Street
Springfield, Illinois 62703-2886

CONSTRUCT A 2,065' X 35'
PARTIAL PARALLEL TAXIWAY
TO RUNWAY 13/31

PROPOSED ELECTRICAL PLAN
400' RT.

JAN 11, 2013 1:19 PM HARR01115
pw:\s\spi-svr306\hanson\Documents\09\jobs\09A0031\09A0031\09A0031\09A0031\09A0031.dwg\Airport\Sheet\C-142-ELEC

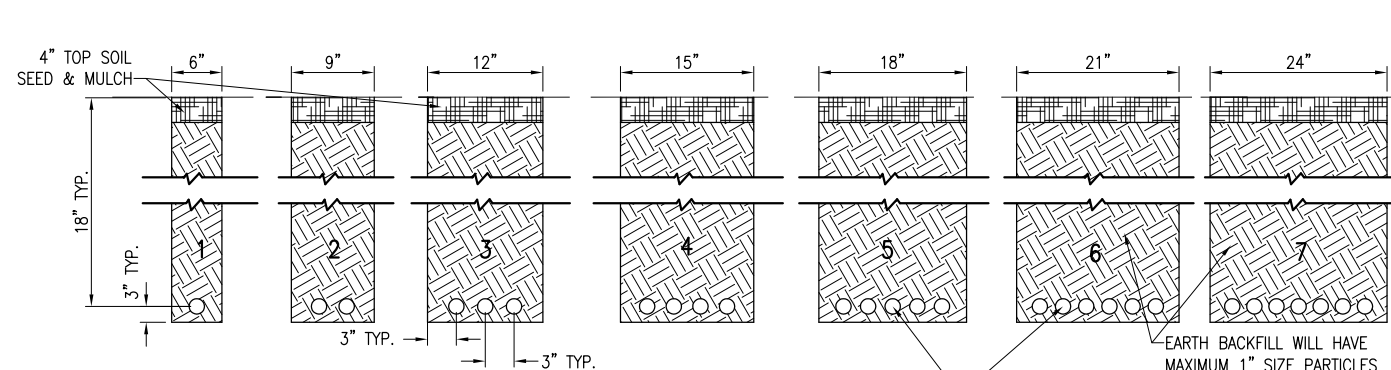

NOTES:
 DETAIL NUMBERS INDICATE NO. OF CABLES.
 TRENCHES WITH MORE THAN SEVEN CABLES SHALL BE INCREASED 3" IN WIDTH FOR EACH ADDITIONAL CABLE; IF SPECIFIED ON PLANS TWO PARALLEL TRENCHES MAY BE CONSTRUCTED.
 DEPTH OF TRENCHES SHALL BE AS SHOWN ABOVE UNLESS OTHERWISE SPECIFIED ON THE PLANS.
 ALL DISTURBED SURFACES SHALL BE RESTORED TO THEIR ORIGINAL CONDITION. COST IS INCIDENTAL TO TRENCH.

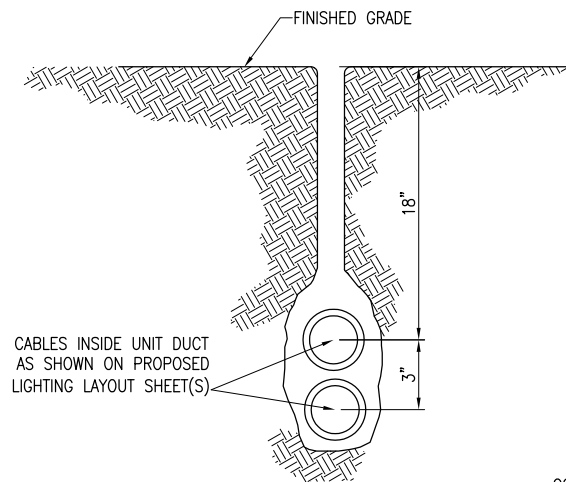

PLOWED CABLE
(NOT TO SCALE)

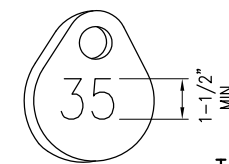

TAG DETAIL
(NOT TO SCALE)

NOTE:
 AFFIX NON-CORROSIVE TAG TO FIXTURE FACING RUNWAY WITH SET SCREW, WIRE TIE, OR METAL BAND. NUMERALS SHALL BE ENGRAVED FOR PERMANENT READABILITY.

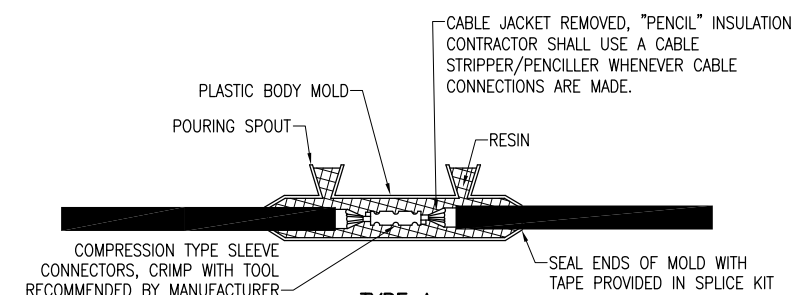

TYPE A

FOR SPLICES IN LOW VOLTAGE CABLE (600V) HOMERUNS FOR EXTENSIONS TO EXISTING LOW VOLTAGE CABLES ONLY

CONTINUOUS HEAT SHRINK TUBING PLACED OVER THE ENTIRE L-823 CONNECTOR(S) BOTH MALE AND FEMALE AT ALL 5KV JUNCTIONS. THE HEAT SHRINK TUBING SHALL BE APPROXIMATELY 18" IN LENGTH WITH 6 INCHES OF MASTIC ON BOTH ENDS AND VOID OF MASTIC IN MIDDLE OF TUBE RATED FOR 5KV.

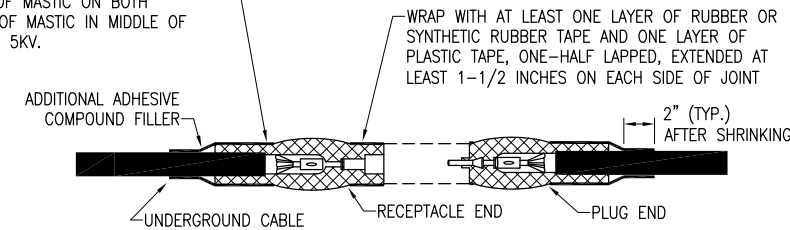

TYPE B

FOR SPLICES AT JUNCTION OF HOMERUN WITH LOOP CIRCUIT AND FOR SPLICES IN HOMERUNS TO EXISTING CABLES

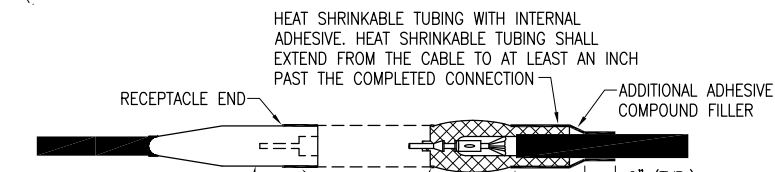

TYPE C

FOR SPLICES AT RUNWAY AND TAXIWAY LIGHTS
 HEAT SHRINKABLE TUBING WITH INTERNAL ADHESIVE. HEAT SHRINKABLE TUBING SHALL EXTEND FROM THE CABLE TO AT LEAST AN INCH PAST THE COMPLETED CONNECTION

NOTES:
 SEE PROPOSED LIGHTING LAYOUT SHEET(S) FOR SPLICE TYPE.
 INSIDE DIAMETER OF CONNECTOR SHALL PROPERLY MATCH THE OUTSIDE DIAMETER OF CABLE.

CABLE SPLICES
(NOT TO SCALE)

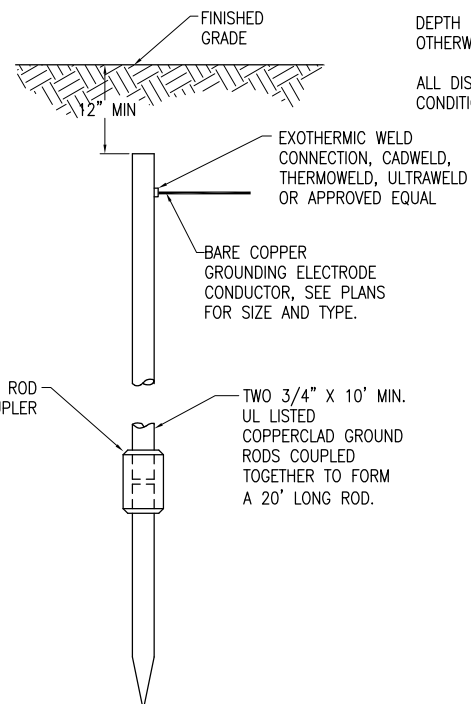

CABLE TRENCHES
(NOT TO SCALE)

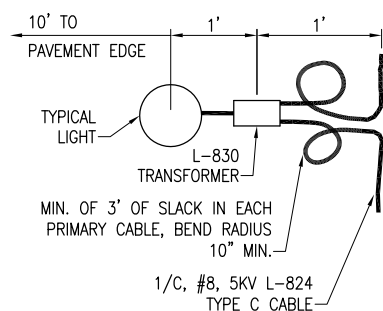

PLAN VIEW

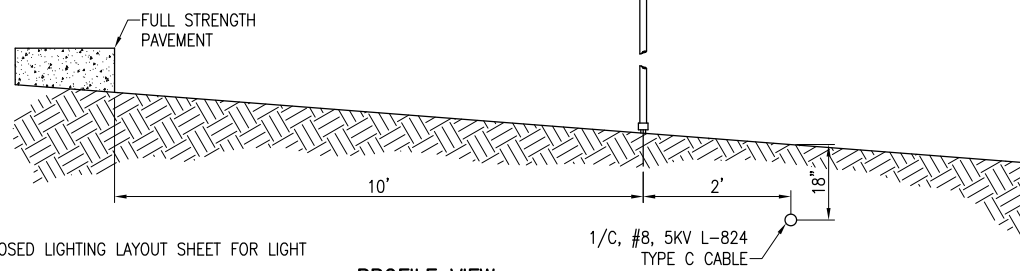

PROFILE VIEW

LIGHT AND CABLE INSTALLATION DETAIL
(NOT TO SCALE)

PER FAA AC 150/5340-30G DESIGN AND INSTALLATION DETAILS FOR AIRPORT VISUAL AIDS, A LIGHT BASE GROUND MUST BE INSTALLED AT EACH LIGHT FIXTURE. A LIGHT BASE GROUND SHALL BE INSTALLED AT EACH STAKE MOUNTED LIGHT AND EACH TRANSFORMER BASE/LIGHT CAN ASSOCIATED WITH RUNWAY LIGHTS, TAXIWAY LIGHTS, AND LIGHTED TAXI GUIDANCE SIGNS. THE LIGHT BASE GROUND SHALL BE A #6 AWG BARE COPPER CONDUCTOR CONNECTED TO THE GROUND LUG ON THE RESPECTIVE L-867 TRANSFORMER BASE/LIGHT CAN OR MOUNTING STAKE AND A 3/4-INCH DIAMETER BY 20-FOOT LONG (MINIMUM) UL LISTED COPPER CLAD GROUND ROD.

NOTES:
 SEE PROPOSED LIGHTING LAYOUT SHEET FOR LIGHT LOCATIONS.

NOTES:
 TYPE AND MINIMUM NUMBER OF GROUND RODS SHALL BE AS SPECIFIED ON THE PLAN.
 THE RESISTANCE TO GROUND OF THE GROUNDING SYSTEM SHALL NOT EXCEED 25 OHMS.
 COST OF GROUND RODS IS INCIDENTAL TO THE ASSOCIATED ITEMS REQUIRING GROUNDING UNLESS OTHERWISE SPECIFIED.

GROUND ROD
(NOT TO SCALE)

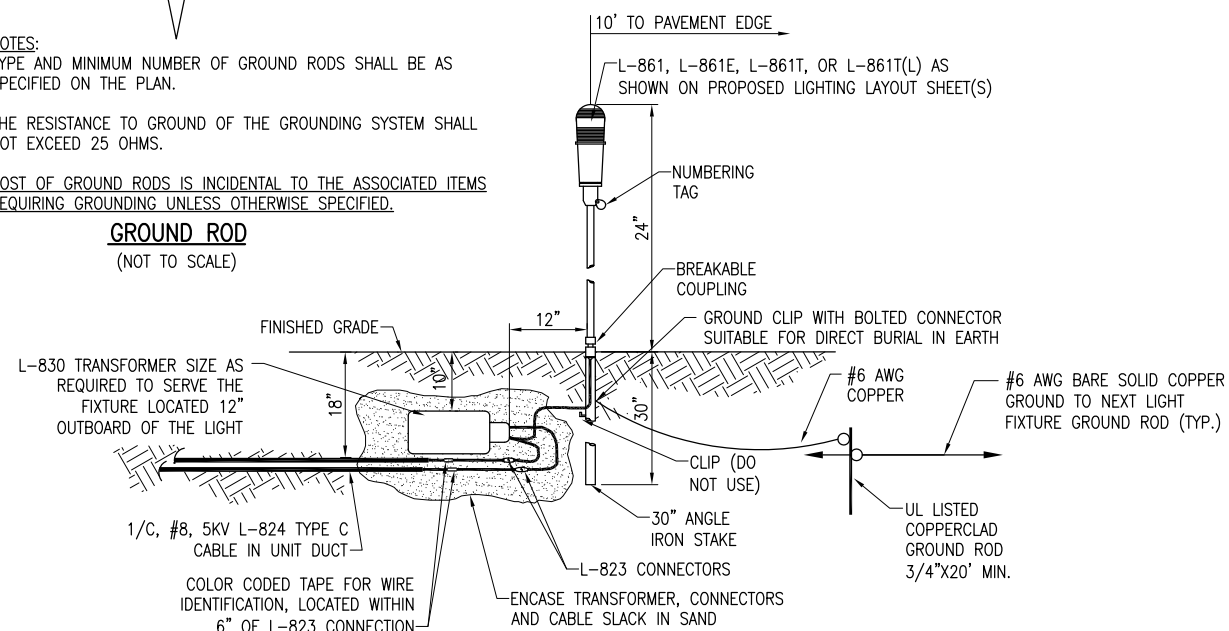

MEDIUM INTENSITY LIGHT - STAKE MOUNTED
(NOT TO SCALE)

NOTES

- SEE "ELECTRICAL DETAILS SHEET 2" FOR MEDIUM INTENSITY LIGHT BASE MOUNTED DETAILS

REVISION	
DATE	

MARSHALL COUNTY AIRPORT
LACON, ILLINOIS

IL PROJ.: C75-4218 BLOCK GRANT: 3-17-0059-B14

Hanson Project No.	09A0031	LAYOUT	KNL	08/16/12
Filename	E-501-ELEC.dwg	DRAWN	BAK	08/16/12
Scale	NOT TO SCALE	REVIEWED	BSS	01/11/13
Date	01/11/13			



CONSTRUCT A 2,065' X 35' PARTIAL PARALLEL TAXIWAY TO RUNWAY 13/31

ELECTRICAL DETAILS SHEET 1

JAN 11, 2013 1:20 PM HARR01115
 p:\s\svr306\hanson\Projects\Documents\09jobs\09A0031\CAD\Airport\Sheet\E-501-ELEC

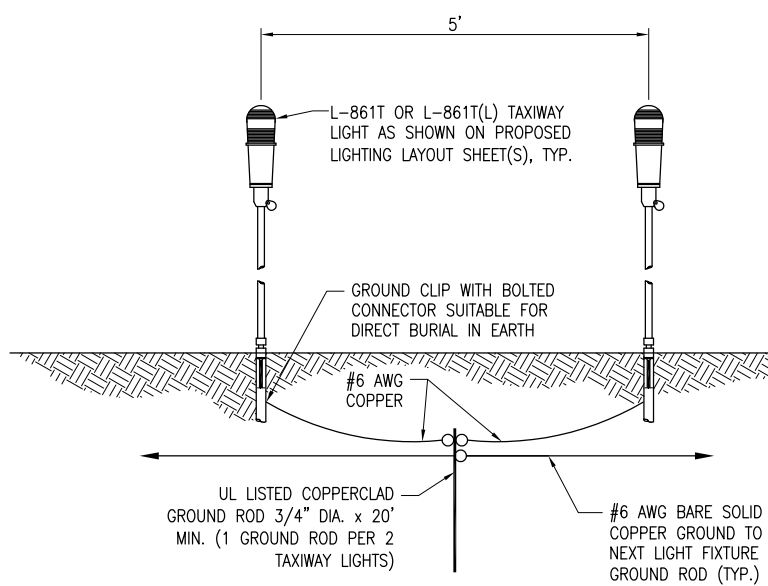

GROUNDING DETAIL FOR ADJACENT TAXIWAY LIGHTS
(NOT TO SCALE)

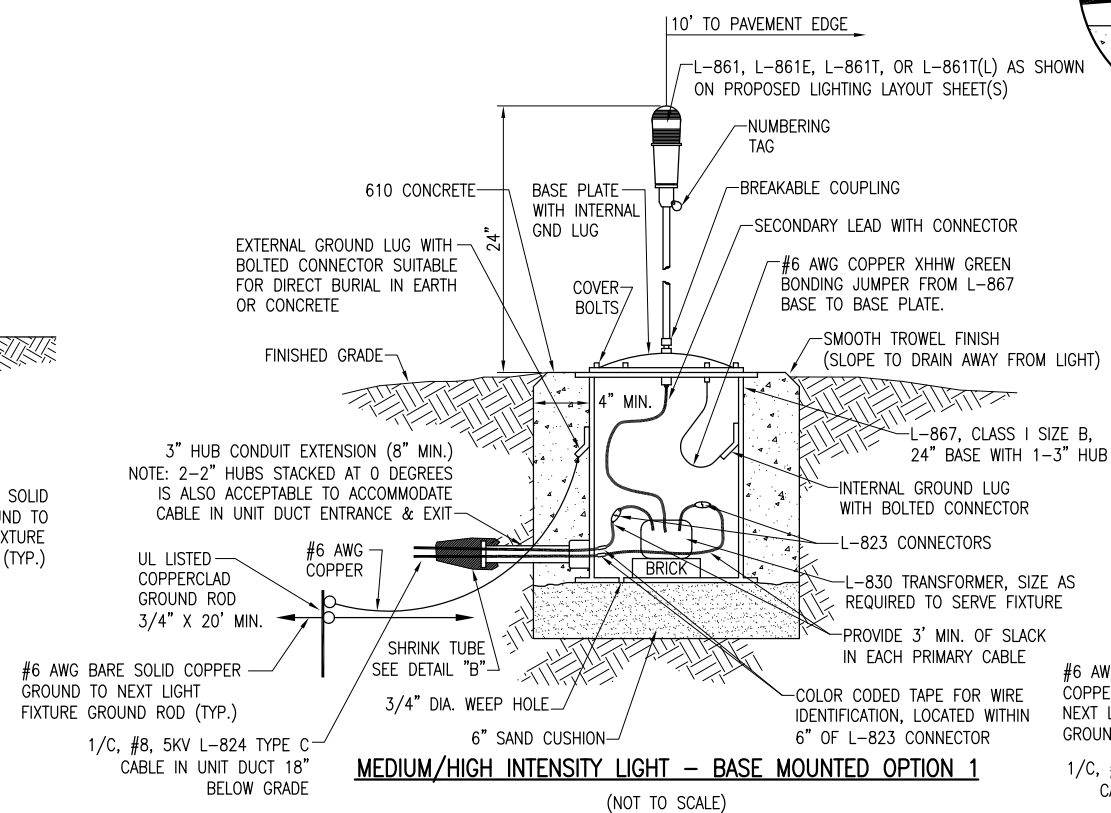

MEDIUM/HIGH INTENSITY LIGHT - BASE MOUNTED OPTION 1
(NOT TO SCALE)

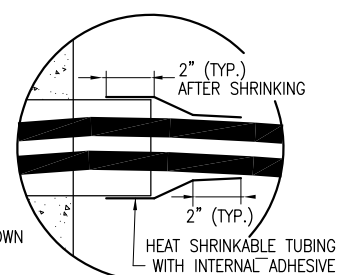

DETAIL "B"
(NOT TO SCALE)

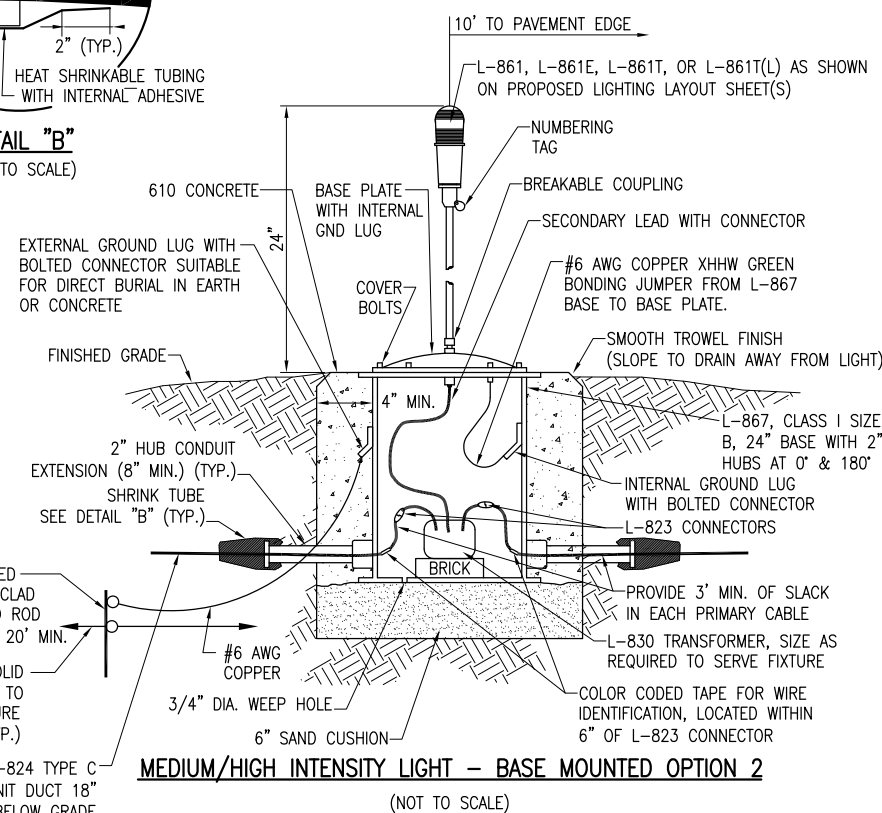

MEDIUM/HIGH INTENSITY LIGHT - BASE MOUNTED OPTION 2
(NOT TO SCALE)

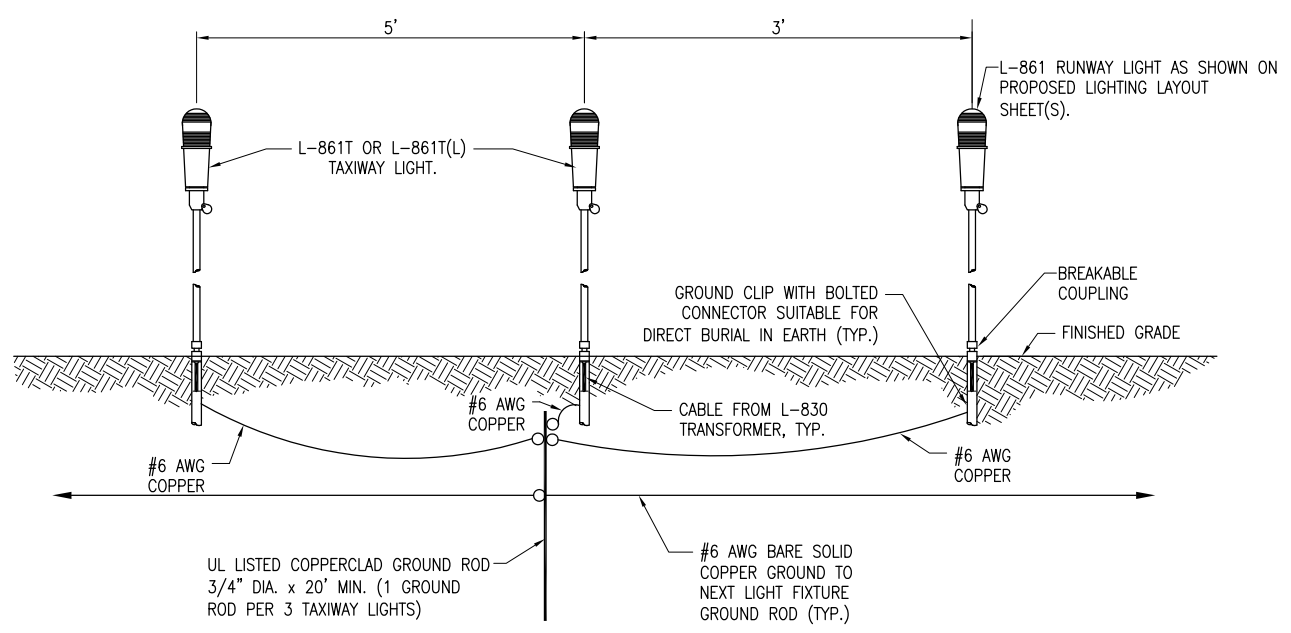

GROUNDING DETAIL FOR ADJACENT RUNWAY AND TAXIWAY LIGHTS
(NOT TO SCALE)

NOTES

- GROUNDING FOR RUNWAY LIGHTS, TAXIWAY LIGHTS, AND LIGHTED TAXI GUIDANCE SIGNS SHALL BE AS DETAILED ON THE PLANS AND AS SPECIFIED HEREIN. PER FAA AC 150/5340-30G DESIGN AND INSTALLATION DETAILS FOR AIRPORT VISUAL AIDS, CHAPTER 12, PART 12.6; A GROUND MUST BE INSTALLED AT EACH LIGHT FIXTURE. THE PURPOSE OF THE LIGHT BASE GROUND IS TO PROVIDE A DEGREE OF PROTECTION FOR MAINTENANCE PERSONNEL FROM POSSIBLE CONTACT WITH AN ENERGIZED LIGHT BASE OR MOUNTING STAKE THAT MAY RESULT FROM A SHORTED POWER CABLE OR ISOLATION TRANSFORMER. A LIGHT BASE GROUND SHALL BE INSTALLED AT EACH TRANSFORMER BASE/LIGHT CAN ASSOCIATED WITH RUNWAY LIGHTS, TAXIWAY LIGHTS, AND LIGHTED TAXI GUIDANCE SIGNS. A LIGHT BASE GROUND SHALL ALSO BE INSTALLED AT EACH STAKE MOUNTED LIGHT FIXTURE. A LIGHT BASE GROUND SHALL BE INSTALLED AND CONNECTED TO THE METAL FRAME OF EACH TAXI GUIDANCE SIGN AS DETAILED ON THE PLANS AND IN ACCORDANCE WITH THE RESPECTIVE TAXI GUIDANCE SIGN MANUFACTURER RECOMMENDATIONS. THE LIGHT BASE GROUND SHALL BE A #6 AWG BARE COPPER CONDUCTOR BONDED TO THE GROUND LUG ON THE RESPECTIVE L-867 TRANSFORMER BASE/LIGHT CAN OR MOUNTING STAKE AND A 3/4-INCH DIAMETER BY 20-FOOT LONG (MINIMUM) UL LISTED COPPER CLAD GROUND ROD. (TWO 3/4-INCH DIAMETER BY 10-FOOT LONG, UL LISTED COPPER CLAD GROUND RODS COUPLED TOGETHER). 20-FOOT LONG GROUND RODS ARE REQUIRED DUE TO POOR RESISTANCE OF THE SOIL AT THE RESPECTIVE SITE. CONNECTIONS TO GROUND LUGS ON THE L-867 TRANSFORMER BASE/LIGHT CAN OR MOUNTING STAKE SHALL BE WITH A UL LISTED GROUNDING CONNECTOR SUITABLE FOR DIRECT BURIAL IN EARTH OR CONCRETE. CONNECTIONS TO GROUND RODS SHALL BE MADE WITH EXOTHERMIC WELD TYPE CONNECTORS, CADWELD BY ERICO PRODUCTS, INC., SOLON, OHIO, (PHONE: 800-248-9353), THERMOWELD BY CONTINENTAL INDUSTRIES, INC., TULSA, OKLAHOMA (PHONE: 918-663-1440), ULTRAWELD BY HARGER, GRAYSLAKE, ILLINOIS (PHONE: 800-842-7437), OR APPROVED EQUAL. EXOTHERMIC WELD CONNECTIONS SHALL BE INSTALLED IN CONFORMANCE WITH THE RESPECTIVE MANUFACTURER'S DIRECTIONS USING MOLDS AS REQUIRED FOR EACH RESPECTIVE APPLICATION. BOLTED CONNECTIONS WILL NOT BE PERMITTED AT GROUND RODS. TOP OF GROUND RODS SHALL BE BURIED 12 INCHES MINIMUM BELOW GRADE, UNLESS SPECIFIED OTHERWISE HEREIN, FOR RESPECTIVE APPLICATIONS.
- FOR BASE MOUNTED LIGHT FIXTURES THE LIGHT FIXTURE MUST BE BONDED TO THE LIGHT BASE INTERNAL GROUND LUG VIA A #6 AWG STRANDED COPPER WIRE RATED FOR 600 VOLTS WITH GREEN XHHW OR USE INSULATION. THE GROUND WIRE LENGTH MUST BE SUFFICIENT TO ALLOW THE REMOVAL OF THE LIGHT FIXTURE FROM THE LIGHT BASE FOR ROUTINE MAINTENANCE. SEE THE LIGHT FIXTURE MANUFACTURER'S INSTRUCTIONS FOR PROPER METHODS OF ATTACHING A BONDING WIRE.
- FURNISH AND INSTALL A #6 AWG BARE SOLID COPPER GROUND AND BOND IT TO EACH GROUND ROD AT THE RESPECTIVE AIRFIELD LIGHT FIXTURES AND TAXI GUIDANCE SIGNS. THE #6 AWG GROUND SHALL BE DIRECT BURIAL IN TRENCH APPROXIMATELY 12 TO 18 INCHES BELOW GRADE. THE GROUND CONDUCTOR MAY BE INSTALLED ABOVE THE #8 FAA L-824, 5000-VOLT CABLE IN UNIT DUCT OR IN AN ADJACENT TRENCH. THE #6 AWG GROUND SHALL BE CONNECTED TO EACH RESPECTIVE GROUND ROD WITH AND EXOTHERMIC WELD CONNECTION. THE COMPLETED GROUND WIRE INSTALLED WILL PROVIDE A GROUND RING SYSTEM FOR THE RESPECTIVE AIRFIELD LIGHTING CIRCUIT. THE GROUND WIRE WILL NOT BE INSTALLED WITH THE HOMERUN CABLES FOR THE #6 AWG BARE SOLID COPPER GROUND WILL BE PAID FOR UNDER ITEM AR108756 1/C #6 GROUND PER LINEAR FOOT.
- FOR TAXIWAY LIGHTS THAT ARE SPACED WITH LESS THAN 10 FEET OF SEPARATION BETWEEN THEM PROVIDE ONE 3/4-INCH DIAMETER BY 20-FOOT LONG GROUND ROD PER TWO ADJACENT TAXIWAY LIGHTS.
- STEEL USED TO MANUFACTURE GROUND RODS SHALL BE 100% DOMESTIC STEEL.

REVISION				
DATE				
MARSHALL COUNTY AIRPORT LACON, ILLINOIS				
BLOCK GRANT: 3-17-0059-B14 IL PROJ.: C75-4218				
Hanson Project No.	09A0031	LAYOUT	KNL	08/20/12
Filename	E-502-ELEC.dwg	DRAWN	BAK	08/20/12
Scale	NOT TO SCALE	REVIEWED	BSS	01/11/13
Date	01/11/13			
HANSON				
© Copyright Hanson Professional Services Inc. 2012 Hanson Professional Services Inc. 1525 S. Rock Street Springfield, Illinois 62703-2886				
CONSTRUCT A 2,065' X 35' PARTIAL PARALLEL TAXIWAY TO RUNWAY 13/31				
ELECTRICAL DETAILS SHEET 2				
54				
54 of 79 sheets				

JAN 11, 2013 1:20 PM HARR01115
 p:\s\sp\sw306\hanson\Documents\09A0031\09A0031D\CAD\Airport\Sheet\E-502-ELEC

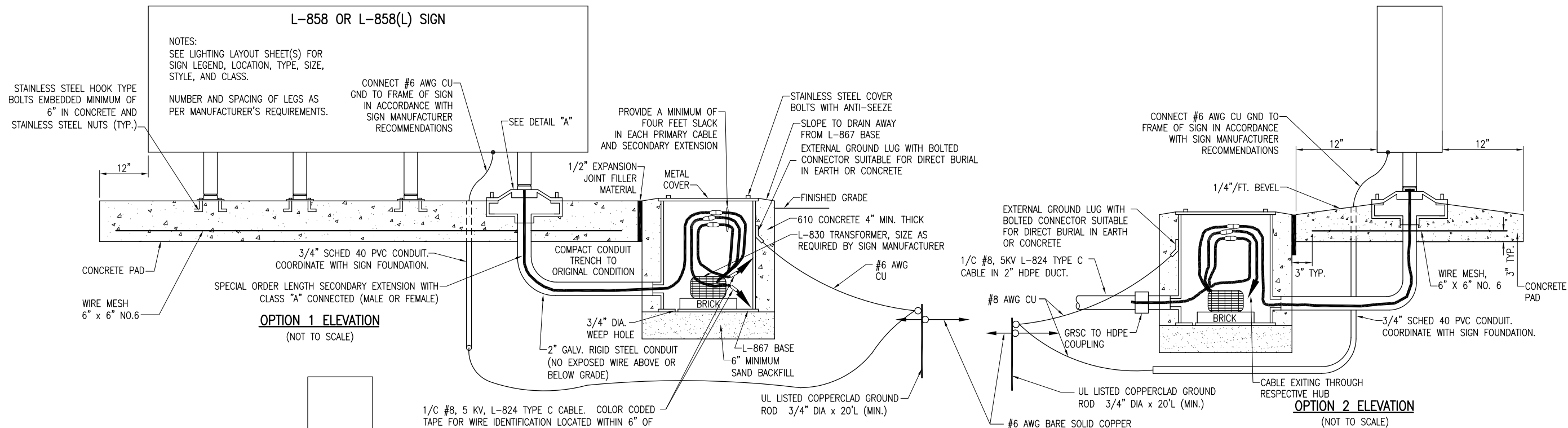

- ① EXISTING SOD TO BE STRIPPED AND REMOVED
- ② SAND BACKFILL, VARIABLE DEPTH
- ③ PROPOSED TOPSOIL BACKFILL MATERIAL

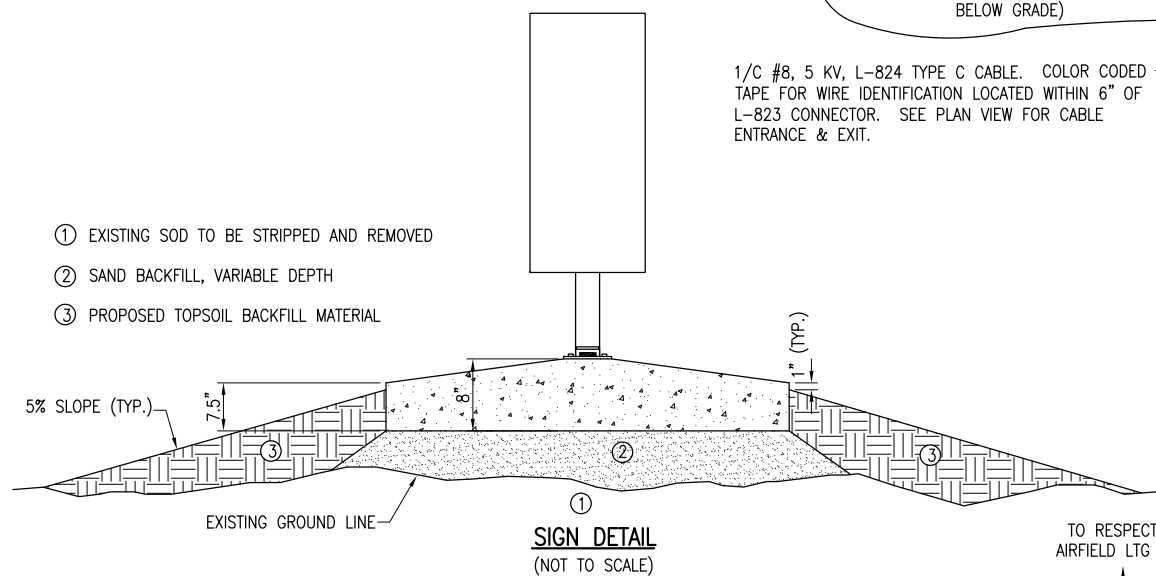

PER FAA AC 150/5340-30G DESIGN AND INSTALLATION DETAILS FOR AIRPORT VISUAL AIDS, A LIGHT BASE GROUND MUST BE INSTALLED AT EACH LIGHT FIXTURE. A LIGHT BASE GROUND SHALL BE INSTALLED AT EACH STAKE MOUNTED LIGHT AND EACH TRANSFORMER BASE/LIGHT CAN ASSOCIATED WITH RUNWAY LIGHTS, TAXIWAY LIGHTS, AND LIGHTED TAXI GUIDANCE SIGNS. THE LIGHT BASE GROUND SHALL BE A #6 AWG BARE COPPER CONDUCTOR CONNECTED TO THE GROUND LUG ON THE RESPECTIVE L-867 TRANSFORMER BASE/LIGHT CAN, TAXI SIGN FRAME, OR MOUNTING STAKE AND A 3/4-INCH DIAMETER BY 20-FOOT LONG (MINIMUM) UL LISTED COPPER CLAD GROUND ROD. ALSO BOND THE SIGN FRAME TO THE GROUND ROD WITH A #6 AWG BARE COPPER CONDUCTOR.

- GENERAL NOTES**
1. SEE LIGHTING LAYOUT SHEET FOR SIGN LEGEND, LOCATION, TYPE, SIZE, STYLE, AND CLASS.
 2. SEE ELECTRICAL NOTES SHEETS.

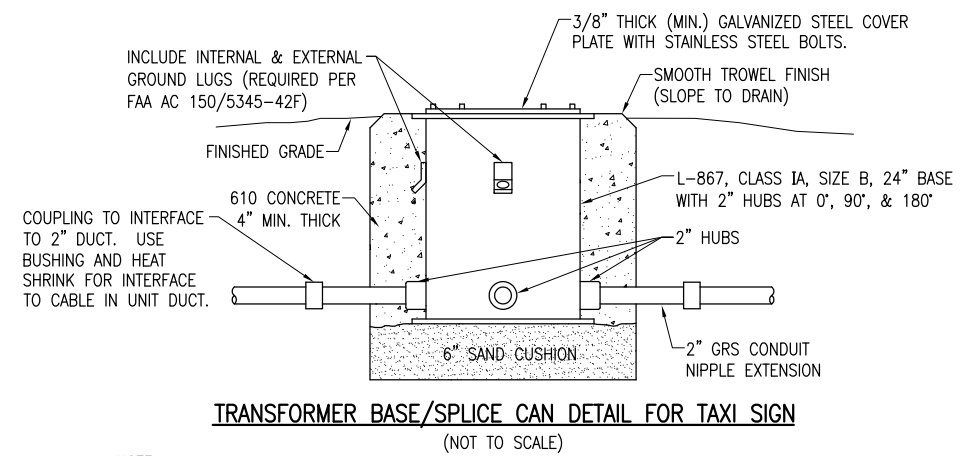
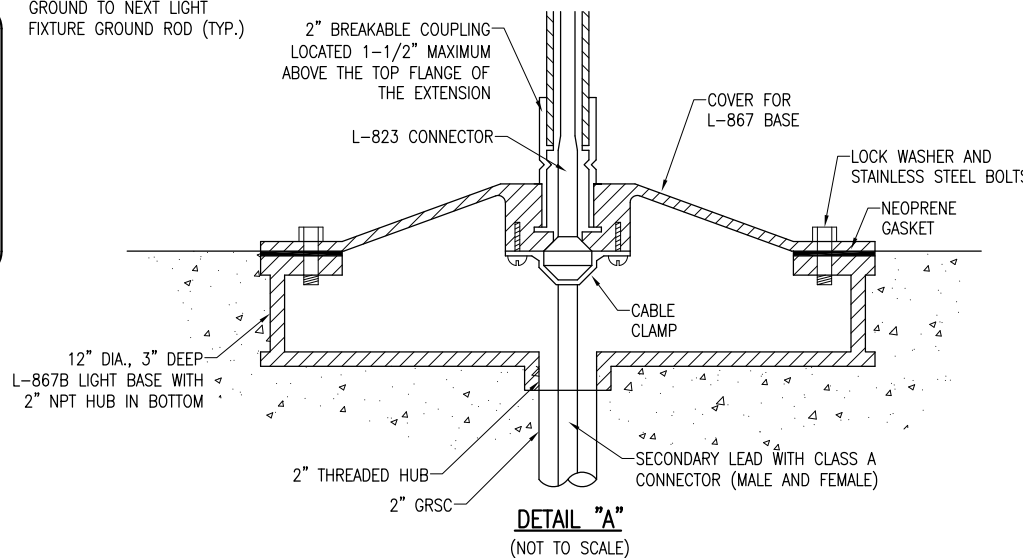
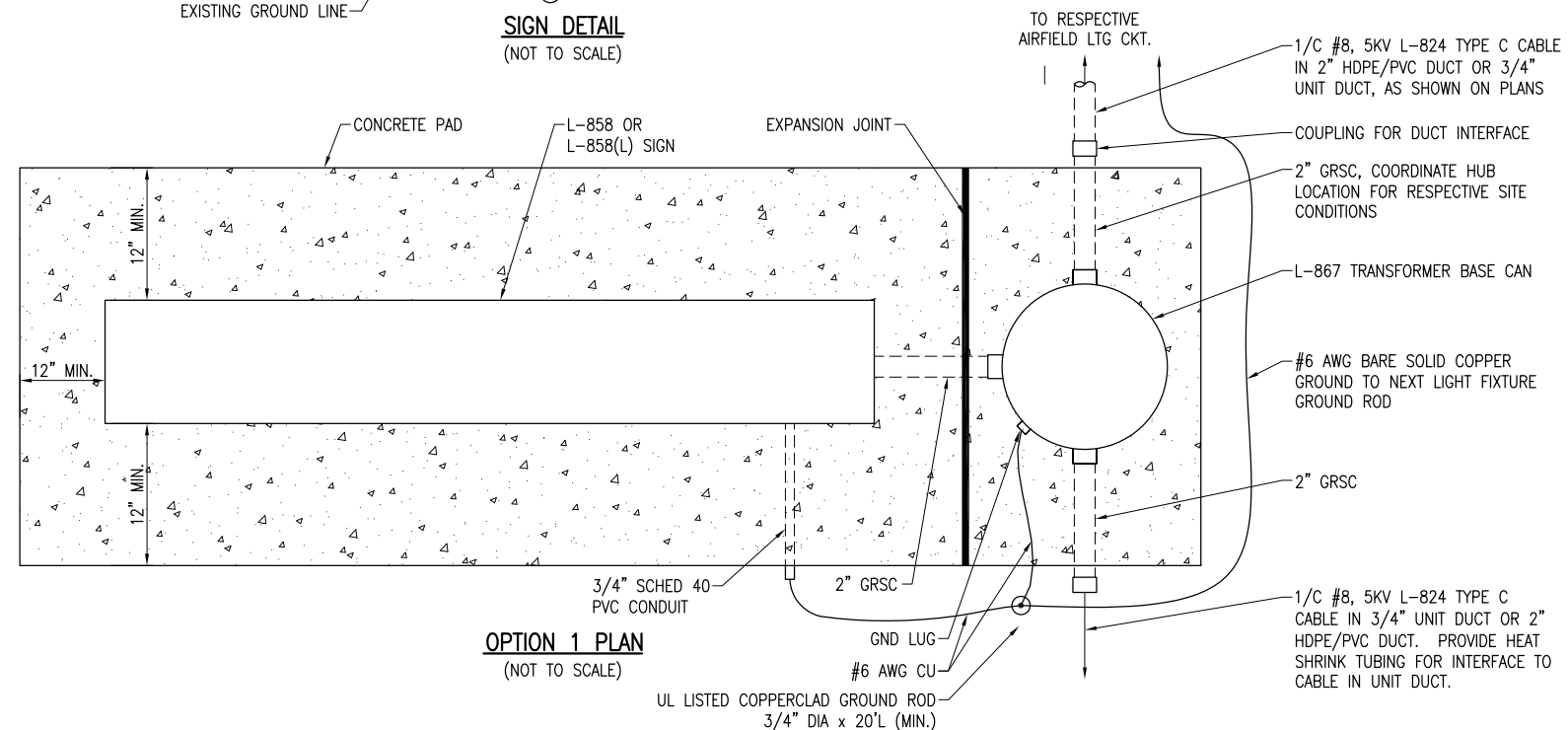

NOTE:
FOR THE PURPOSE OF ENHANCING SAFETY, EACH BASE MUST HAVE INSTALLED, BY THE MANUFACTURER, AN INTERNAL AND EXTERNAL GROUND STRAP THAT IS AVAILABLE FOR THE PURPOSE OF ATTACHING A GROUND LUG THAT IS CONNECTED TO AN EARTH GROUND OR A SAFETY GROUND CONDUCTOR INSTALLED WITH THE RESPECTIVE CIRCUIT. FOR AIRPORT PROJECTS RECEIVING FEDERAL FUNDS THIS REQUIREMENT IS MANDATORY PER FAA AC 150/5345-42F.

REVISION	DATE

MARSHALL COUNTY AIRPORT
LACON, ILLINOIS

PROJECT: C75-4218
BLOCK GRANT: 3-17-0059-B14
IL PROJ.: C75-4218

Hanson Project No.	09A0031
Filename	E-503-ELEC.DWG
Scale	NOT TO SCALE
Date	01/11/13
LAYOUT	KNL 08/20/12
DRAWN	BAK 08/20/12
REVIEWED	BSS 01/11/13



CONSTRUCT A 2,065' X 35'
PARTIAL PARALLEL TAXIWAY
TO RUNWAY 13/31

ELECTRICAL DETAILS
SHEET 3

JAN 11, 2013 1:20 PM HARR01115
pw:\sps-sv306\hanson\Projects\Documents\09\jobs\09A0031\09A0031D\CAD\Airport\Sheet\E-503-ELEC

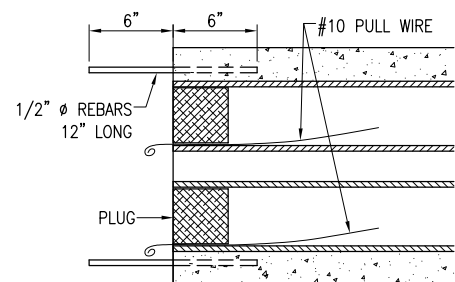

DUCT BANK TYPICAL SECTION
"NOT TO SCALE"

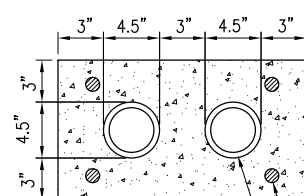

2-DUCT BANK
"NOT TO SCALE"

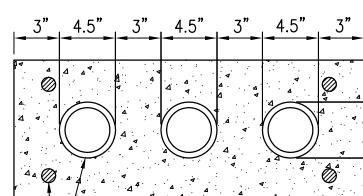

3-DUCT BANK
"NOT TO SCALE"

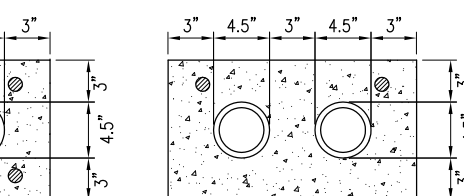

4-DUCT BANK
"NOT TO SCALE"

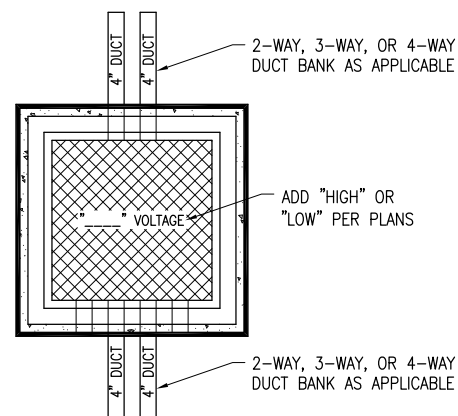

HEAVY DUTY FRAME & LID SUITABLE FOR H-20 LOADING, NEENAH CAT. NO. R-6662-PP OR APPROVED EQUAL

SMOOTH TROWEL FINISH (SLOPE TO DRAIN)

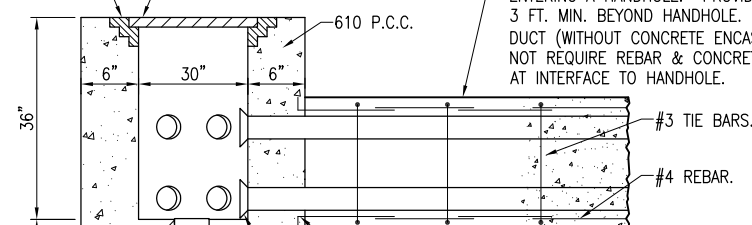

6" SCHED 40 PVC DRAIN PIPE. FILL WITH PEA GRAVEL TO ACCOMMODATE DRAINAGE. NOTE 6" OF CA-7 GRAVEL MAY BE PROVIDED, INSTEAD OF 6" CONCRETE FLOOR WITH DRAIN PIPE, AT CONTRACTORS OPTION.

EXTEND NO. 4 REBAR INTO HANDHOLE APPROX 3". PROVIDE 90° "L" HOOK ON REBAR TERMINATION IN HANDHOLE. (TYP.) OR EXTEND REBAR EPOXY ANCHORED INTO HANDHOLE WITH 4" EMBEDMENT.

PROVIDE CONDUIT BUSHING OR BELL AT TERMINATION IN HANDHOLE (TYP.)

NOTES:

- LIDS FOR LOW VOLTAGE HANDHOLES SHALL BE LABELED "LOW VOLTAGE". LIDS FOR HIGH VOLTAGE HANDHOLES SHALL BE LABELED "HIGH VOLTAGE". COORDINATE LETTERING WITH MFR.
- HANDHOLES MAY BE CAST IN PLACE OR PRECAST CONCRETE. PRECAST MANUFACTURERS MUST BE ON THE IDOT (ILLINOIS DEPT. OF TRANSPORTATION) APPROVED LIST OF CERTIFIED PRECAST CONCRETE PRODUCERS. FIBERGLASS HANDHOLES ARE NOT ACCEPTABLE.
- ALL CORING, INTERFACE, AND LABOR ASSOCIATED WITH CONDUIT, DUCT, CABLE IN UNIT DUCT, AND / OR CABLE ENTRIES WILL BE CONSIDERED INCIDENTAL TO THE INSTALLATION OF THE HANDHOLE AND NO ADDITIONAL COMPENSATION WILL BE ALLOWED.
- INCLUDE CERTIFICATION OF MANUFACTURE IN THE UNITED STATES OF AMERICA WITH HANDHOLE SHOP DRAWING SUBMITTAL.

ELECTRICAL HANDHOLE
"NOT TO SCALE"

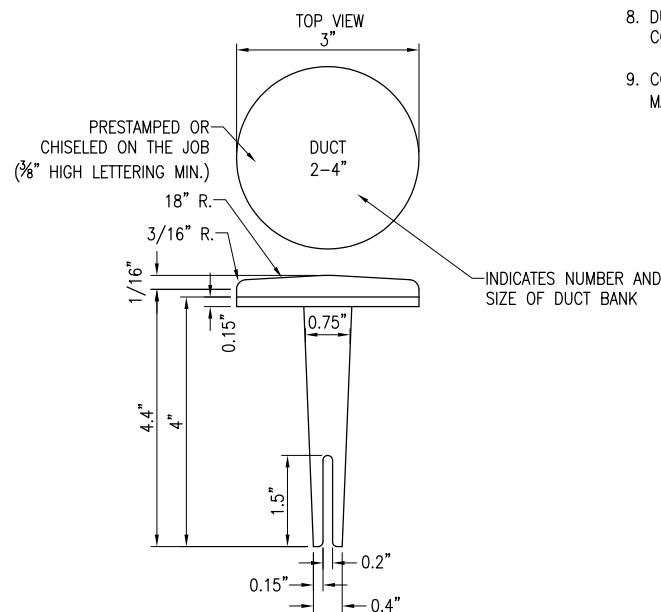

BITUMINOUS PAVEMENT DUCT MARKERS
"NOT TO SCALE"

NOTES:

- TOP OF MARKER SHALL BE FLUSH WITH FINISHED PAVEMENT SURFACE. MARKER MAY BE INSTALLED IN A DRILLED HOLE AND SECURED WITH EPOXY GLUE.
- BRASS DUCT MARKERS ARE AVAILABLE FROM G&S FOUNDRY & MANUFACTURING CO. INC., 210 KASKASKIA DRIVE, RED BUD, IL. 62278, PHONE (618) 282-4114, OR APPROVED EQUAL.

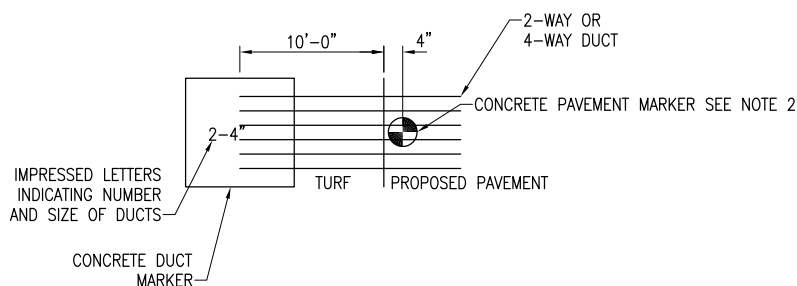

DUCT MARKER DETAIL
"NOT TO SCALE"

DUCT BANK NOTES:

- DIMENSIONS FOR CONCRETE COVERAGE AND SEPARATION BETWEEN DUCTS ARE MINIMUM.
- INCLUDE DUCT SPACERS AS MANUFACTURED BY UNDERGROUND DEVICES INC., OR APPROVED EQUAL TO MAINTAIN PROPER SEPARATION OF CONDUITS.
- REBAR IS REQUIRED TO ACCOMMODATE FUTURE DUCT EXTENSIONS & INTERFACE AT DUCT BANK TERMINATIONS. CONCRETE ENCASED DUCT BANKS TERMINATING IN HANDHOLES REQUIRE REBAR AT TERMINATIONS.
- CONDUITS FOR CONCRETE ENCASED DUCT SHALL BE SCHEDULE 40 PVC CONFORMING TO ITEM 110.
- MINIMUM DEPTH OF TOP OF DUCT ENCASEMENT SHALL BE 18" BELOW FINISHED GRADE.
- HIGH VOLTAGE AND LOW VOLTAGE CIRCUITS SHALL NOT BE INSTALLED IN THE SAME RACEWAY, CONDUIT, DUCT, HANDHOLE, OR MANHOLE.
- HOMERUN CABLES FOR A RESPECTIVE CIRCUIT SHALL BE INSTALLED IN THE SAME RACEWAY OR DUCT.
- DUCT INTERFACE TO HANDHOLES OR MANHOLES WILL BE CONSIDERED INCIDENTAL TO THE RESPECTIVE DUCT PAY ITEM.
- CONCRETE ENCASED DUCTS AND/OR DIRECT BURY DUCTS SHALL MAINTAIN 3" MINIMUM SEPARATION BETWEEN DUCTS.

CABLE & DUCT MARKER NOTES:

- THE COST OF ALL TURF AND PAVEMENT DUCT MARKERS SHALL BE INCIDENTAL TO THE DUCT. THE COST OF ALL CABLE MARKERS SHALL BE INCIDENTAL TO THE CABLE.
- BITUMINOUS PAVEMENT DUCT MARKER AND CONCRETE DUCT MARKER TO BE PROVIDED AT EACH END OF EACH DUCT AS SHOWN ON THE LOCATION PLAN. FOR CONCRETE PAVEMENT, THE LETTER "D" SHALL BE IMPRESSED IN THE PAVEMENT INSTEAD OF THE MARKER. THE LETTER SHALL BE FORMED AS DESCRIBED IN NOTE 4.
- CABLE MARKERS SHALL BE PLACED AT CHANGES OF DIRECTION AND APPROXIMATELY EVERY 200' ALONG CABLE RUNS.
- CONCRETE CABLE MARKERS AND DUCT MARKERS SHALL HAVE LETTERS 4" HIGH, 3" WIDE WITH WIDTH OF STROKE 1/2" AND 1/4" DEEP. ALL LETTERS, NUMBERS AND ARROWS TO BE IMPRESSED.

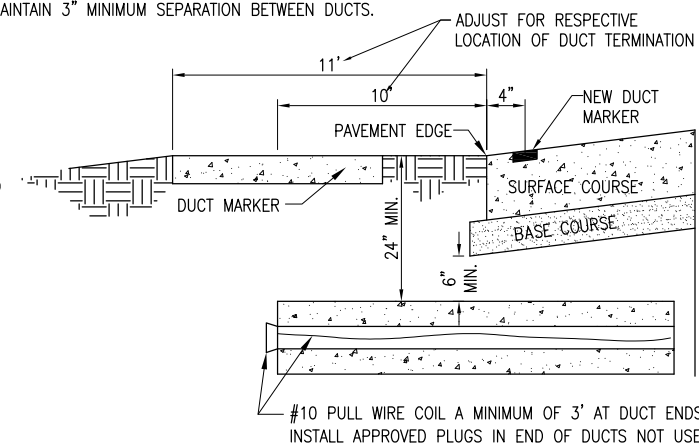

UNDERGROUND ELECTRICAL DUCT
"NOT TO SCALE"

#10 PULL WIRE COIL A MINIMUM OF 3' AT DUCT ENDS. INSTALL APPROVED PLUGS IN END OF DUCTS NOT USED.

IMPRESSED LETTERS AND DIRECTIONAL ARROW, ADJUST TO CABLE LAYOUT

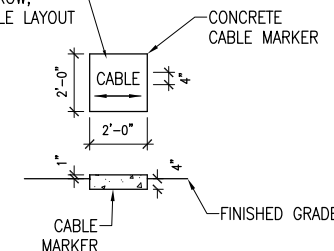

TURF CABLE MARKERS
"NOT TO SCALE"

IMPRESSED NUMBERS NOTING NUMBER & SIZE OF DUCTS. ADJUST FOR RESPECTIVE QUANTITY & SIZE OF DUCTS

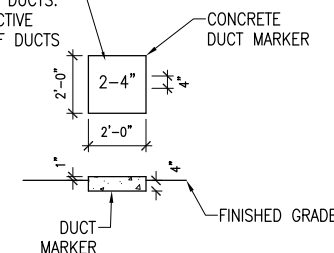

TURF DUCT MARKERS
"NOT TO SCALE"

REVISION	
DATE	
MARSHALL COUNTY AIRPORT LACON, ILLINOIS	
BLOCK GRANT: 3-17-0059-B14	
IL PROJ.: C75-4218	

Hanson Project No.	09A0031
Filename	E-504-ELEC.dwg
Scale	NOT TO SCALE
Date	01/11/13
LAYOUT	KNL 08/20/12
DRAWN	BAK 08/20/12
REVIEWED	BSS 01/11/13

HANSON

© Copyright Hanson Professional Services Inc. 2012
Hanson Professional Services Inc.
1525 S. Main Street
Springfield, Illinois 62703-2886

CONSTRUCT A 2,065' X 35'
PARTIAL PARALLEL TAXIWAY
TO RUNWAY 13/31

ELECTRICAL DETAILS
SHEET 4

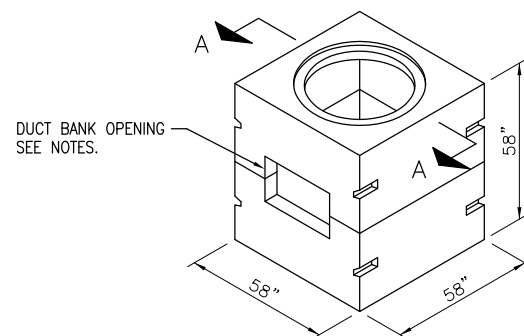
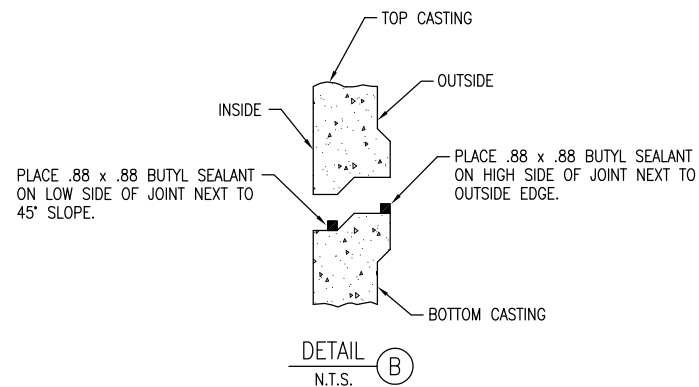

PRECAST 4'x4'x4' ELECTRICAL MANHOLE NOTES

1. 4'x4'x4' ELECTRICAL MANHOLE SHALL BE CONSTRUCTED TO MEET THE FOLLOWING:

DESIGN CRITERIA:

- 1) DESIGN SPECIFICATION: ACI 318, AASHTO LOAD FACTOR DESIGN METHOD, AND ASTM C858
- 2) DESIGN LOADING: AASHTO HS20 (32,000 LB/AXLE)
- 3) LIVE LOAD SURCHARGE: .5% OF THE WHEEL LOADING APPLIED TO 8'-0" OF DEPTH.
- 4) CONCRETE COMPRESSIVE STRENGTH: $F'_c = 4500$ PSI
- 5) REINFORCING STEEL: ASTM A706, $F_y = 60000$ PSI

DESIGN ASSUMPTIONS:

- 1) GROUND WATER LEVEL: 3'-6" BELOW GRADE.
- 2) EARTH COVER: 2'-0" MINIMUM TO 5'-0" MAXIMUM
- 3) LIVE LOAD IMPACT: 2'-0" $I = 20\%$
2'-1" TO 2'-11" $I = 10\%$
3'-0" TO 5'-0" $I = 0\%$
- 4) COEFFICIENT OF ACTIVE EARTH PRESSURE: $K_a = 0.3$
- 5) SPECIFIC WEIGHT OF STD. AGGREGATE CONCRETE: 150 PCF
- 6) SPECIFIC WEIGHT OF DRY EARTH: 100 PCF
- 7) SPECIFIC WEIGHT OF SATURATED EARTH: 120 PCF
- 8) EQUIVALENT FLUID PRESSURE OF DRY EARTH: 30 PSF
- 9) EQUIVALENT FLUID PRESSURE OF SATURATED EARTH: 80 PSF

THE SUPPLIER SHALL PROVIDE CERTIFICATION THAT THE PRECAST MANHOLES MEET OR EXCEED THESE REQUIREMENTS PRIOR TO INSTALLATION.

2. MANHOLE FRAME & LID SHALL BE CAPABLE OF WITHSTANDING MINIMUM 50,000 POUND LOADS. MANHOLE FRAME & LID SHALL BE NEENAH CATALOG NO. R-1640-C OR APPROVED EQUAL. LID FOR HIGH VOLTAGE MANHOLE SHALL BE LABELED "HIGH VOLTAGE". LID FOR LOW VOLTAGE MANHOLE SHALL BE LABELED "LOW VOLTAGE" OR "OV-600V".
3. COORDINATE DUCT BANK INTERFACE & OPENINGS WITH THE MANHOLE MFR. CONTRACTOR SHALL SLOPE DUCT BANK TO PRECAST MANHOLE OPENINGS. ALL OPENINGS SHALL BE SEALED WATERTIGHT AFTER DUCT BANK INSTALLATION.
4. 4'x4'x4' MANHOLE SHALL BE MANUFACTURED BY A CONCRETE ELECTRICAL MANHOLE PRODUCER ON THE ILLINOIS DEPARTMENT OF TRANSPORTATION APPROVED LIST OF CERTIFIED PRECAST CONCRETE PRODUCERS. MANHOLE PRODUCER SHALL SUBMIT CERTIFICATION THAT THE RESPECTIVE PRE-CAST MANHOLES ARE MANUFACTURED IN THE UNITED STATES.
5. 4'x4'x4' MANHOLE SHALL BE PAID FOR UNDER ITEM AR110710 ELECTRICAL MANHOLE PER EACH.
6. CABLE RACKS SHALL BE HEAVY DUTY CORROSION RESISTANT NYLON MATERIAL WITH CORROSION RESISTANT STAINLESS STEEL MOUNTING HARDWARE; UNDERGROUND DEVICES, INC. CAT. NO. 3SR1N, 3SR2N OR 3SR3N OR EQUAL. PROVIDE AT LEAST TWO TRIPLE HOOK CABLE RACKS ON EACH MANHOLE WALL, SPACED TO SUPPORT RESPECTIVE CABLES.
7. COORDINATE INSTALLATION OF MANHOLES WITH RESPECTIVE FINISHED GRADE ELEVATIONS.

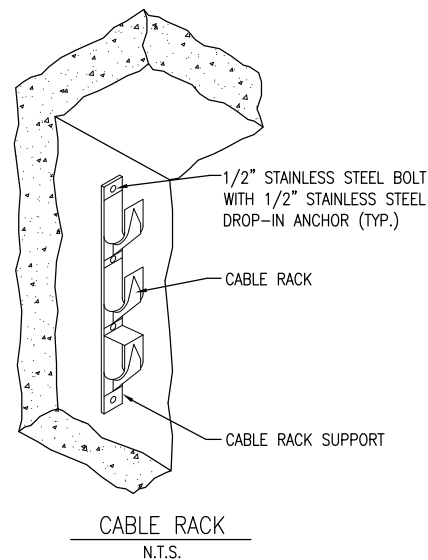
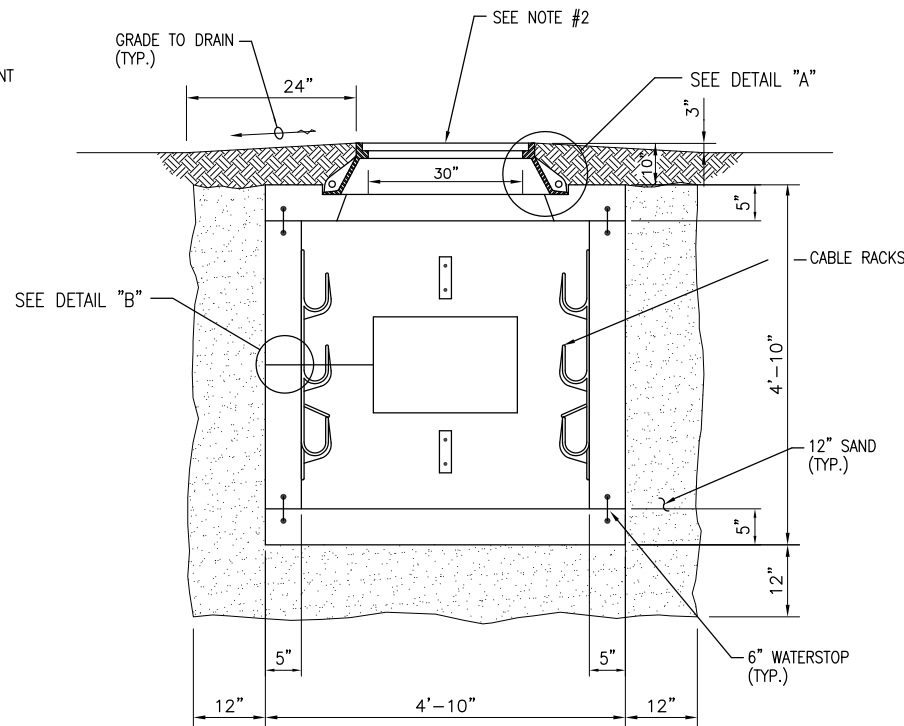
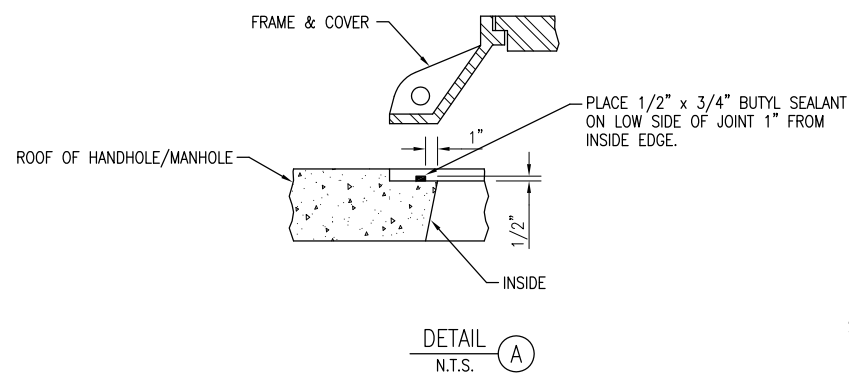

PRECAST 4' x 4' x 4' MANHOLE DETAILS
N.T.S. (NOT TO SCALE)

REVISION	DATE

MARSHALL COUNTY AIRPORT
LACON, ILLINOIS

IL PROJ.: C75-4218 BLOCK GRANT: 3-17-0059-B14

Hanson Project No.	09A0031	LAYOUT	KNL	12/17/12
Filename	E-507-ELEC.dwg	DRAWN	MLH	12/17/12
Scale	NOT TO SCALE	REVIEWED	BSS	01/11/13
Date	01/11/13			



© Copyright Hanson Professional Services Inc. 2012
Hanson Professional Services Inc.
1425 South Rock Street
Springfield, Illinois 62703-2886

CONSTRUCT A 2,065' X 35'
PARTIAL PARALLEL TAXIWAY
TO RUNWAY 13/31

4' X 4' X 4' ELECTRICAL
MANHOLE

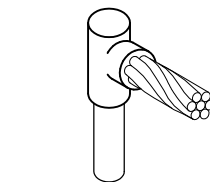

CABLE TO GROUND ROD

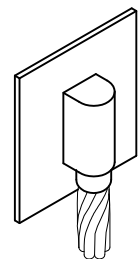

CABLE TO SURFACE

DETAIL NOTES

- EXOTHERMIC WELDS SHALL BE CADWELD AS MANUFACTURED BY ERICO PRODUCTS, SOLON, OHIO, ULTRAWELD AS MANUFACTURED BY HARGER LIGHTNING PROTECTION & GROUNDING EQUIPMENT, GRAYSLAKE, IL, THERMOWELD AS MANUFACTURED BY CONTINENTAL INDUSTRIES, TULSA, OKLAHOMA OR APPROVED EQUAL. VERIFY PROPER SIZES, MOLDS, TYPES, AND REQUIREMENTS FOR THE RESPECTIVE APPLICATION WITH THE MANUFACTURER, AND INSTALL PER THEIR DIRECTIONS.
- FOR APPLICATIONS TO GALVANIZED STEEL OR PAINTED STEEL, REMOVE GALVANIZING AND/OR PAINT & CLEAN THE SURFACE TO EXPOSE BARE STEEL BEFORE MAKING EXOTHERMIC WELD CONNECTION.
- VERIFY EXOTHERMIC MOLDS ARE SUITABLE FOR USE WITH THE RESPECTIVE TYPE (SOLID OR STRANDED) & SIZE CONDUCTOR.

EXOTHERMIC WELD DETAILS
"NOT TO SCALE"

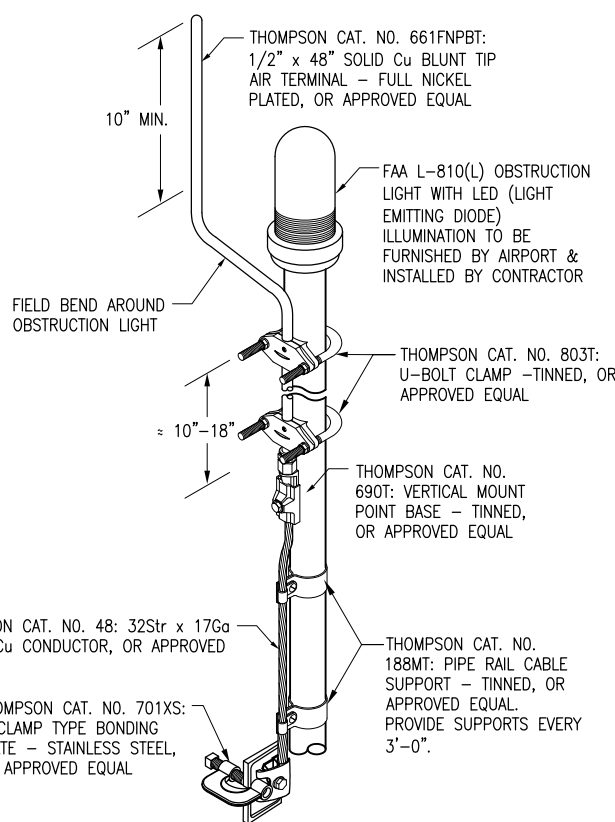

DETAIL A
"NOT TO SCALE"

NOTES

- REFERENCES TO THOMPSON ARE THOMPSON LIGHTNING PROTECTION INC., 901 SIBLEY MEMORIAL HWY, ST. PAUL, MN 55188, PHONE: 651-455-7661, 800-777-1230, FAX: 651-455-2545.
- VERIFY LIGHTNING PROTECTION COMPONENTS AND CATALOG NUMBERS WITH THE RESPECTIVE LIGHTNING PROTECTION EQUIPMENT MANUFACTURER.
- CLEAN ALL CONNECTIONS TO EXPOSE BARE METAL.

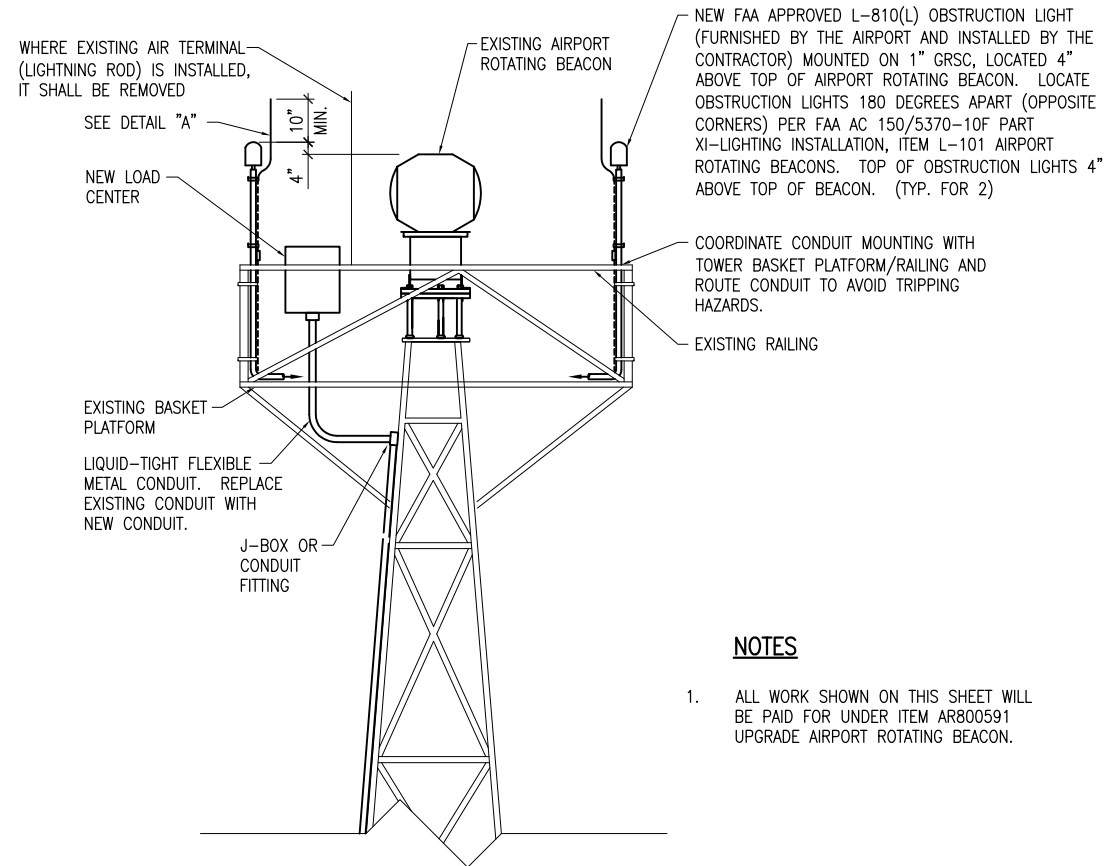

NOTES

- ALL WORK SHOWN ON THIS SHEET WILL BE PAID FOR UNDER ITEM AR800591 UPGRADE AIRPORT ROTATING BEACON.

2#8 THWN
1#8 NEUTRAL
1#8 GND
IN 1" MIN. GRSC FROM LIGHTING CONTACTOR PANEL TO BEACON LOAD CENTER. XLP-USE OR XHHW WIRING IS ALSO ACCEPTABLE.

#2 AWG BARE COPPER GROUNDING ELECTRODE CONDUCTOR. BOND TO TOWER FRAME AT OPPOSITE CORNERS (2 LOCATIONS) WITH EXOTHERMIC WELD

GRSC TO PLASTIC COUPLING.

TRANSITION TO HDPE DUCT OR SCHED 40 PVC BELOW GRADE.

NEW 3/4" DIA. X 20' LONG UL LISTED COPPER CLAD GROUND ROD. (TYPICAL FOR 2) LOCATE GROUND RODS AT OPPOSITE CORNERS OF TOWER FOUNDATION. GROUND RODS SHALL NOT BE SPACED LESS THAN 20 FEET APART. COORDINATE LOCATIONS OF GROUND RODS WITH OTHER WORK, IN THE AREA.

LIGHTNING PROTECTION DETAIL
FOR AIRPORT ROTATING BEACON
"NOT TO SCALE"

EXISTING TOWER FOUNDATION

AIRPORT ROTATING BEACON LOAD CENTER SCHEDULE			
CKT #	DUTY	SIZE	CKT #
1	AIRPORT ROTATING BEACON	15A 1P	2
3	OBSTRUCTION LIGHTS	15A 1P	4
5	BLANK		6
7	BLANK		8
9	BLANK		10
11	BLANK		12

SIZE	DUTY
30A 1P	SURGE PROTECTOR (PHASE A)
30A 1P	SURGE PROTECTOR (PHASE B)
	BLANK
	BLANK
	BLANK
	BLANK

100 AMP, 120/240 VAC, 1 PHASE, 3 WIRE, 12 CIRCUIT LOAD CENTER WITH MAIN LUGS IN A NEMA 3R RAIN PROOF ENCLOSURE, SQUARE D CAT. NO. Q0112L125GRB WITH EQUIPMENT GROUND BAR KIT OR APPROVED EQUAL. CONFIRM LOAD CENTER IS MADE IN THE USA TO COMPLY WITH THE AIRPORT IMPROVEMENT PROGRAM BUY AMERICAN REQUIREMENT.

NOTES

- INCLUDE EQUIPT GROUND BAR KIT.
- ALL BREAKERS SHALL HAVE 10,000 AIC RATING AT 120/240 VAC.
- PHASE "A" SHALL BE SWITCHED THROUGH A LIGHTING CONTACTOR AT THE VAULT. PHASE "B" SHALL BE UNSWITCHED.
- INCLUDE ENGRAVED PHENOLIC LEGEND PLATE LABELED ARB PANEL, 120/240 VAC, 1PH, 3W, FED FROM VAULT.
- SURGE PROTECTORS SHALL BE SUITABLE FOR 120VAC, 1PH, 2W PLUS GROUND, 30KA (MINIMUM) SURGE CURRENT RATING, JOSLYN MODEL 1260-21 OR LIGHTING PROTECTION CORP. MODEL LPC 11765-132, OR APPROVED EQUAL. FURNISH & INSTALL TWO SURGE PROTECTORS (ONE FOR EACH PHASE).
- LOAD CENTER SHALL BE MANUFACTURED IN THE UNITED STATES TO COMPLY WITH THE AIRPORT IMPROVEMENT PROGRAM BUY AMERICAN REQUIREMENTS. PROVIDE CERTIFICATION OF MANUFACTURE IN THE UNITED STATES WITH SHOP DRAWING SUBMITTAL.

REVISION	DATE

MARSHALL COUNTY AIRPORT
LACON, ILLINOIS

IL PROJ.: C75-4218 BLOCK GRANT: 3-17-0059-B14

Hanson Project No.	09A0031
Filename	E-506-ELEC.dwg
Scale	NOT TO SCALE
Date	01/11/13
LAYOUT	KNL 11/11/12
DRAWN	MLH 11/18/12
REVIEWED	BSS 01/11/13



CONSTRUCT A 2,065' X 35' PARTIAL PARALLEL TAXIWAY TO RUNWAY 13/31

AIRPORT ROTATING BEACON UPGRADE DETAILS AND NOTES

JAN 11, 2013 1:20 PM HARR01115
pw:\sps-sv306\hanson\Documents\09A0031\09A0031D\CAD\Airport\Sheet\E-506-ELEC

GENERAL NOTES

- ALL ELECTRICAL EQUIPMENT SHALL BE INSTALLED IN CONFORMANCE WITH NFPA 70 – NATIONAL ELECTRICAL CODE (NEC) MOST CURRENT ISSUE IN FORCE, THE RESPECTIVE EQUIPMENT MANUFACTURER'S DIRECTIONS AND ALL OTHER APPLICABLE LOCAL CODES, LAWS, ORDINANCES, AND REQUIREMENTS IN FORCE. ANY INSTALLATIONS WHICH VOID THE U.L. LISTING, ETL LISTING (OR OTHER THIRD PARTY LISTING) AND/OR THE MANUFACTURER'S WARRANTY OF A DEVICE WILL NOT BE PERMITTED.
- CONTRACTOR SHALL KEEP A COPY OF THE LATEST NEC IN FORCE ON SITE AT ALL TIMES DURING CONSTRUCTION FOR USE AS A REFERENCE.
- CONTRACTOR SHALL COORDINATE WORK AND ANY POWER OUTAGES AND/OR SHUT DOWN OF SYSTEMS WITH THE RESPECTIVE FACILITY OWNER PERSONNEL AND THE AIRPORT MANAGER/DIRECTOR. ONCE SHUT DOWN, THE CIRCUITS SHALL BE LABELED AS SUCH TO PREVENT ACCIDENTAL ENERGIZING OF THE RESPECTIVE CIRCUITS. ALL PERSONNEL SHALL FOLLOW U.S. DEPARTMENT OF LABOR OCCUPATIONAL SAFETY & HEALTH ADMINISTRATION (OSHA) 29 CFR PART 1910 OCCUPATIONAL SAFETY & HEALTH STANDARDS FOR ELECTRICAL SAFETY AND LOCKOUT/TAGOUT PROCEDURES INCLUDING, BUT NOT LIMITED TO, 29 CFR SECTION 1910.147 THE CONTROL OF HAZARDOUS ENERGY (LOCKOUT/TAGOUT).
- THE CONTRACTOR SHALL ASCERTAIN THAT ALL LIGHTING SYSTEM COMPONENTS FURNISHED BY HIM, INCLUDING FAA APPROVED EQUIPMENT, ARE COMPATIBLE IN ALL RESPECTS WITH EACH OTHER AND THE REMAINDER OF THE NEW/EXISTING SYSTEM. ANY NONCOMPATIBLE COMPONENTS FURNISHED BY THIS CONTRACTOR SHALL BE REPLACED BY HIM AT NO ADDITIONAL COST TO THE AIRPORT SPONSOR WITH A SIMILAR UNIT, APPROVED BY THE ENGINEER (DIFFERENT MODEL OR DIFFERENT MANUFACTURER) THAT IS COMPATIBLE WITH THE REMAINDER OF THE AIRPORT LIGHTING SYSTEM.
- IN CASE THE CONTRACTOR ELECTS TO FURNISH AND INSTALL AIRPORT LIGHTING EQUIPMENT REQUIRING ADDITIONAL WIRING, TRANSFORMERS, ADAPTORS, MOUNTINGS, ETC., TO THOSE SHOWN ON THE DRAWINGS AND/OR LISTED IN THE SPECIFICATION, ANY COST FOR THESE ITEMS SHALL BE INCIDENTAL TO THE EQUIPMENT COST.
- THE CONTRACTOR INSTALLED EQUIPMENT (INCLUDING FAA APPROVED) SHALL NOT GENERATE ANY ELECTROMAGNETIC INTERFERENCE IN THE EXISTING AND/OR NEW COMMUNICATIONS, WEATHER, AIR NAVIGATION, AND AIR TRAFFIC CONTROL EQUIPMENT. ANY EQUIPMENT GENERATING SUCH INTERFERENCE SHALL BE REPLACED BY THE CONTRACTOR AT NO ADDITIONAL COST WITH THE EQUIPMENT MEETING THE APPLICABLE SPECIFICATIONS AND NOT GENERATING ANY INTERFERENCE.
- WHEN A SPECIFIC TYPE, STYLE, CLASS, ETC. OF FAA APPROVED EQUIPMENT IS SPECIFIED ONLY THAT TYPE, STYLE, CLASS, WILL BE ACCEPTABLE, EVEN THOUGH EQUIPMENT OF OTHER TYPES STYLES, CLASSES, ETC. MAY BE APPROVED.
- ANY AND ALL INSTRUCTIONS FROM THE RESIDENT ENGINEER/RESIDENT PROJECT REPRESENTATIVE TO THE CONTRACTOR REGARDING CHANGES IN OR DEVIATIONS FROM THE PLANS AND SPECIFICATIONS SHALL BE IN WRITING WITH COPIES SENT TO THE AIRPORT SPONSOR AND THE ILLINOIS DEPARTMENT OF TRANSPORTATION DIVISION OF AERONAUTICS). THE CONTRACTOR SHALL NOT ACCEPT ANY VERBAL INSTRUCTIONS FROM THE RESIDENT ENGINEER/RESIDENT PROJECT REPRESENTATIVE REGARDING ANY CHANGES FROM THE PLANS AND SPECIFICATIONS.
- A MINIMUM OF THREE COPIES OF THE INSTRUCTION BOOK SHALL BE SUPPLIED WITH EACH DIFFERENT TYPE OF EQUIPMENT. THE BOOKS DESCRIBING A MORE SOPHISTICATED TYPE OF EQUIPMENT, SUCH AS REGULATORS, PAPI, REIL, ETC. AS A MINIMUM SHALL CONTAIN THE FOLLOWING:
 - A DETAILED DESCRIPTION OF THE OVERALL EQUIPMENT AND ITS INDIVIDUAL COMPONENTS.
 - THEORY OF OPERATION INCLUDING THE FUNCTION OF EACH COMPONENT.
 - INSTALLATION INSTRUCTION.
 - START-UP INSTRUCTIONS.
 - PREVENTATIVE MAINTENANCE REQUIREMENTS.
 - CHART FOR TROUBLE-SHOOTING.
 - COMPLETE POWER AND CONTROL DETAILED WIRING DIAGRAM(S), SHOWING EACH CONDUCTOR/CONNECTION/COMPONENT – "BLACK" BOXES ARE NOT ACCEPTABLE. THE DIAGRAM OF THE NARRATIVE SHALL SHOW VOLTAGE/CURRENTS/WAVE SHAPES AT STRATEGIC LOCATIONS TO BE USED WHEN CHECKING AND/OR TROUBLE-SHOOTING THE EQUIPMENT. WHEN THE EQUIPMENT HAS SEVERAL MODES OF OPERATION, SUCH AS SEVERAL BRIGHTNESS STEPS, THESE PARAMETERS SHALL BE INDICATED FOR ALL DIFFERENT MODES.
 - PARTS LIST WHICH WILL INCLUDE ALL MAJOR AND MINOR COMPONENTS SUCH AS RESISTORS, DIODES, ETC. IT SHALL INCLUDE A COMPLETE NOMENCLATURE OF EACH COMPONENT AND, IF APPLICABLE, THE NAME OF ITS MANUFACTURER AND THE CATALOG NUMBER.
 - SAFETY INSTRUCTIONS.

POWER AND CONTROL NOTES

- PROVIDE LEGEND PLATES FOR ALL ELECTRICAL EQUIPMENT TO IDENTIFY FUNCTION, CIRCUIT VOLTAGE AND PHASE. WHERE THE EQUIPMENT CONTAINS FUSES, ALSO IDENTIFY THE FUSE OR FUSE LINK AMPERE RATING. WHERE THE EQUIPMENT DOES NOT HAVE SUFFICIENT AREA TO INSTALL LEGEND PLATES, THE LEGEND PLATES SHALL BE INSTALLED ON THE WALL NEXT TO THE UNIT. LEGEND PLATES SHALL BE WEATHERPROOF ENGRAVED PLASTIC OR PHENOLIC MATERIAL, 1/4" HIGH BLACK LETTERS ON A WHITE BACKGROUND UNLESS NOTED OTHERWISE. SECURE WITH WEATHERPROOF ADHESIVE AND MACHINE SCREWS. FURNISH ADDITIONAL LEGEND PLATES WHERE REQUIRED BY CODE, FOR ADDITIONAL EQUIPMENT, AS DETAILED HEREIN ON THE PLANS, AND AS NOTED IN THE SPECIAL PROVISION SPECIFICATIONS.
- COLOR CODE ALL PHASE WIRING BY THE USE OF COLORED WIRE INSULATION AND/OR COLORED TAPE. WHERE TAPE IS USED, THE WIRE INSULATION SHALL BE BLACK. BLACK AND RED SHALL BE USED FOR PHASE CONDUCTORS ON 120/240VAC SINGLE-PHASE, THREE WIRE SYSTEMS AND BLACK, ORANGE (FOR HIGH LEG) AND BLUE SHALL BE USED FOR PHASE CONDUCTORS ON 240/120VAC THREE-PHASE, FOUR WIRE SYSTEMS. NEUTRAL CONDUCTORS, SIZE NO. 6 AWG OR SMALLER, SHALL BE IDENTIFIED BY A CONTINUOUS WHITE OR NATURAL GRAY OUTER FINISH ALONG ITS ENTIRE LENGTH. NEUTRAL CONDUCTORS LARGER THAN NO. 6 AWG SHALL BE IDENTIFIED EITHER BY A CONTINUOUS WHITE OR NATURAL GRAY OUTER FINISH ALONG ITS ENTIRE LENGTH OR BY THE USE OF WHITE TAPE AT ITS TERMINATIONS AND INSIDE ACCESSIBLE WIREWAYS. INSULATED GROUND CONDUCTORS SHALL HAVE GREEN COLORED INSULATION FOR ALL CONDUCTOR SIZES (AWG OR KCMIL).
- ALL BRANCH CIRCUIT CONDUCTORS CONNECTED TO A PARTICULAR PHASE SHALL BE IDENTIFIED WITH THE SAME COLOR. THE COLOR CODING SHALL BE EXTENDED TO THE POINT OF UTILIZATION.
- IN CONTROL WIRING THE SAME COLOR SHALL BE USED THROUGHOUT THE SYSTEM FOR THE SAME FUNCTION, SUCH AS 10%, 30%, 100% BRIGHTNESS CONTROL, ETC.
- LOW VOLTAGE (600 V.) AND HIGH VOLTAGE (5000 V.) CONDUCTORS SHALL BE INSTALLED IN SEPARATE WIREWAYS.
- NEATLY LACE WIRING IN DISTRIBUTION PANELS, WIREWAYS, SWITCHES AND JUNCTION/PULL BOXES.
- THE MINIMUM SIZE OF PULL/JUNCTION BOXES, REGARDLESS OF THE QUANTITY AND SIZE OF THE CONDUCTORS SHOWN, SHALL BE AS FOLLOWS:
 - IN STRAIGHT PULLS THE LENGTH OF THE BOX SHALL NOT BE LESS THAN EIGHT TIMES THE TRADE DIAMETER OF THE LARGER CONDUIT. THE TOTAL AREA (INCLUDING THE CONDUIT CROSS-SECTIONAL AREA) OF A BOX END SHALL BE AT LEAST 3 TIMES GREATER THAN THE TOTAL TRADE CROSS-SECTIONAL AREA OF THE CONDUITS TERMINATING AT THE END.
 - IN ANGLE PULLS OR 'U' PULLS THE DISTANCE BETWEEN EACH CONDUIT ENTRY INSIDE THE BOX AND THE OPPOSITE WALL OF THE BOX SHALL NOT BE LESS THAN SIX (6) TIMES THE TRADE DIAMETER OF THE LARGEST CONDUIT. THIS DISTANCE SHALL BE INCREASED FOR ADDITIONAL ENTRIES BY THE AMOUNT OF THE SUM OF THE DIAMETERS OF ALL OTHER CONDUIT ENTRIES ON THE SAME WALL AS THE BOX. THE DISTANCE BETWEEN CONDUIT ENTRIES ENCLOSING THE SAME CONDUCTOR SHALL NOT BE LESS THAN SIX TIMES THE TRADE DIAMETER OF THE LARGEST CONDUIT.
- A RUN OF CONDUIT BETWEEN TERMINATIONS AT EQUIPMENT ENCLOSURES, SQUARE DUCTS AND PULL/JUNCTION BOXES, SHALL NOT CONTAIN MORE THAN THE EQUIVALENT OF FOUR QUARTER BENDS (360 DEGREES TOTAL), INCLUDING THOSE BENDS LOCATED IMMEDIATELY AT THE TERMINATIONS, CAST, CONDUIT TYPE OUTLETS SHALL NOT BE TREATED AS PULL/JUNCTION BOXES.
- EQUIPMENT CABINETS SHALL NOT BE USED AS PULL/JUNCTION BOXES. ONLY WIRING TERMINATING AT THE EQUIPMENT SHALL BE BROUGHT INTO THESE ENCLOSURES.
- SPLICES AND JUNCTION POINTS SHALL BE PERMITTED ONLY IN JUNCTION BOXES, DUCTS EQUIPPED WITH REMOVABLE COVERS, AND AT EASILY ACCESSIBLE LOCATIONS.
- CIRCUIT BREAKERS IN POWER DISTRIBUTION PANEL(S) SHALL BE THERMAL-MAGNETIC MOLDED CASE, PERMANENT TRIP WITH 100 AMPERE, MINIMUM FRAME.
- DUAL LUGS SHALL BE USED WHERE TWO (2) WIRES, SIZE NO. 6 OR LARGER, ARE TO BE CONNECTED TO THE SAME TERMINAL.
- ALL INTERIOR WALL MOUNTED EQUIPMENT ENCLOSURES SHALL BE MOUNTED ON HOT DIPPED GALVANIZED STEEL STRUT SUPPORT, OR STAINLESS STEEL STRUT SUPPORT, WITH CORROSION RESISTANT HARDWARE.
- SUPPORT FOR EXTERIOR MOUNTED EQUIPMENT SHALL USE HOT DIPPED GALVANIZED STEEL STRUT SUPPORT OR STAINLESS STEEL STRUT SUPPORT WITH STAINLESS STEEL HARDWARE. PROVIDE ZINC RICH PAINT APPLIED TO FIELD CUTS OF GALVANIZED STEEL SUPPORT TO MINIMIZE THE POTENTIAL FOR CORROSION PER THE RESPECTIVE STRUT SUPPORT MANUFACTURER'S RECOMMENDATIONS.
- CONDUITS FOR ELECTRIC SERVICE ENTRANCE AND FEEDERS SHALL BE AS DETAILED HEREIN ON THE PLANS. WHERE GALVANIZED RIGID STEEL CONDUIT IS SPECIFIED IT SHALL HAVE THREADED FITTINGS. SET SCREW TYPE FITTINGS WILL NOT BE ACCEPTABLE. CONDUITS FOR UNDERGROUND APPLICATIONS SHALL BE AS DETAILED HEREIN. CONDUITS FOR GROUNDING ELECTRODE CONDUCTORS OR INDIVIDUAL GROUNDING CONDUCTORS SHALL BE SCHEDULE 40 OR SCHEDULE 80 PVC.
- PROVIDE LIQUID TIGHT FLEXIBLE METAL CONDUIT AT CONNECTIONS TO EQUIPMENT SUBJECT TO VIBRATION OR WHERE FLEXIBILITY IS REQUIRED. LIQUID TIGHT FLEXIBLE METAL CONDUIT AND ASSOCIATED FITTINGS SHALL BE U.L. LISTED TO MEET THE REQUIREMENTS OF NEC 350.6, SUITABLE FOR GROUNDING, SUNLIGHT RESISTANT, AND RESISTANT TO OIL, GASOLINE, AND GREASE. LIQUID TIGHT FLEXIBLE METAL CONDUIT THAT IS USED FOR FLEXIBILITY (INCLUDING CONNECTIONS TO MOTORS, TRANSFORMERS, & CONSTANT CURRENT REGULATORS) SHALL REQUIRE AN EXTERNAL BONDING JUMPER OR INTERNAL EQUIPMENT GROUNDING CONDUCTOR PER NEC 350.60. DO NOT INSTALL LIQUID TIGHT FLEXIBLE METAL CONDUIT THAT IS NOT U.L. LISTED. CONFIRM LIQUID-TIGHT FLEXIBLE METAL CONDUIT BEARS THE UL LABEL PRIOR TO INSTALLING IT.
- UNLESS OTHERWISE SHOWN, ALL EXPOSED CONDUITS SHALL BE RUN PARALLEL TO OR AT RIGHT ANGLES WITH THE LINES OF THE STRUCTURE.
- ALL STEEL CONDUITS, FITTINGS, NUTS, BOLTS, ETC. SHALL BE GALVANIZED.
- USE CONDUIT BUSHINGS AT EACH CONDUIT TERMINATION. WHERE NO. 4 AWG OR LARGER UNDERGROUND WIRE IS INSTALLED, USE INSULATED BUSHINGS.
- USE DOUBLE LOCK NUTS AT EACH CONDUIT TERMINATION.
- WRAP ALL PRIMARY AND SECONDARY POWER TRANSFORMER CONNECTIONS WITH SUFFICIENT LAYERS OF INSULATING TAPE (3M SCOTCH 23 ALL-VOLTAGE SPLICING TAPE, 3M SCOTCH 130C LINERLESS RUBBER SPLICING TAPE, OR APPROVED EQUAL) AND COVER WITH VINYL ELECTRICAL TAPE (3M SCOTCH 88 VINYL ELECTRICAL TAPE OR APPROVED EQUAL) FOR FULL VALUE OF CABLE INSULATION VOLTAGE.
- UNLESS OTHERWISE NOTED, ALL SINGLE CONDUCTOR CONTROL WIRING SHALL BE NO. 12 AWG. COPPER MINIMUM.
- THE FOLLOWING SHALL APPLY TO RELAY/CONTACTOR PANELS/ENCLOSURES:
 - FOR INTERIOR LOCATIONS ALL COMPONENTS SHALL BE MOUNTED IN NEMA 12 (DUST TIGHT) ENCLOSURE(S) WITH VERTICALLY HINGED COVERS. FOR EXTERIOR/OUTDOOR LOCATIONS ALL COMPONENTS SHALL BE MOUNTED IN NEMA 4X STAINLESS STEEL ENCLOSURE(S) WITH VERTICALLY HINGED COVERS. ALL CONDUIT ENTRIES INTO NEMA 4, 4X ENCLOSURES SHALL HAVE NEMA 4 HUBS LISTED SUITABLE FOR THE RESPECTIVE ENCLOSURE TO MAINTAIN THE NEMA 4, 4X RATING OF THE ENCLOSURE.
 - THE ENCLOSURE(S) SHALL HAVE AMPLE SPACE FOR THE CIRCUIT COMPONENTS, TERMINAL BLOCKS AND INCOMING AND INTERNAL WIRING.
 - ALL CONTROL CONDUCTOR TERMINATIONS SHALL BE OF THE OPEN-EYE CONNECTOR/SCREW TYPE. SOLDERED CLOSED-EYE TERMINATIONS, OR TERMINATIONS WITHOUT CONNECTORS ARE NOT ACCEPTABLE.
 - WHEN THE ENCLOSURE COVER IS OPENED, ALL CIRCUIT COMPONENTS, WIRING AND TERMINALS SHALL BE EXPOSED AND ACCESSIBLE WITHOUT REMOVAL OF ANY PANELS, COVERS, ETC., EXCEPT THOSE COVERING HIGH VOLTAGE COMPONENTS.
 - ACCESS TO, OR REMOVAL OF A CIRCUIT COMPONENT OR TERMINAL BLOCK WILL NOT REQUIRE THE REMOVAL OF ANY OTHER CIRCUIT COMPONENT OR TERMINAL BLOCK.
 - EACH CIRCUIT COMPONENT SHALL BE CLEARLY IDENTIFIED INDICATING ITS CORRESPONDING NUMBER SHOWN ON THE DRAWINGS AND ITS FUNCTION.
 - A COMPLETE WIRING DIAGRAM SHALL BE MOUNTED ON THE INSIDE OF THE COVER. THE DIAGRAM SHALL REPRESENT EACH CONDUCTOR BY A SEPARATE LINE.
 - THE DIAGRAM SHALL IDENTIFY EACH CIRCUIT COMPONENT AN NUMBERING AND COLOR OF EACH TERMINAL CONDUCTOR AND TERMINAL.
 - ALL WIRING SHALL BE NEATLY TRAINED AND LACED.
 - MINIMUM WIRE SIZE SHALL BE NO. 12 AWG.
- FURNISH & INSTALL A WEATHERPROOF WARNING LABEL FOR EACH METER SOCKET, SERVICE DISCONNECT, SAFETY SWITCH, CUTOUT, PANELBOARD, & CONTROL PANEL TO WARN PERSONS OF POTENTIAL ELECTRIC ARC FLASH HAZARDS, PER THE REQUIREMENTS OF NEC 110.16 "FLASH PROTECTION".

JAN 11, 2013 1:20 PM HARR01115
 pw:\sps-svr306\hanson\Projects\Documents\09\jobs\09A0031\09A0031D\CAD\Airport\Sheet\E-001-NOTE

REVISION		DATE	
MARSHALL COUNTY AIRPORT LACON, ILLINOIS			
Hanson Project No. 09A0031		E-001-NOTE.dwg	
Filename		NOT TO SCALE	
Scale		Date 01/11/13	
LAYOUT	KNL	08/16/12	
DRAWN	BAK	08/16/12	
REVIEWED	BSS	01/11/13	
 Copyright Hanson Professional Services Inc. 2012 Hanson Professional Services Inc. 1425 South Rock Street Springfield, Illinois 62703-2886			
CONSTRUCT A 2,065' X 35' PARTIAL PARALLEL TAXIWAY TO RUNWAY 13/31		ELECTRICAL NOTES SHEET 1	
59		59 of 79 sheets	

BLOCK GRANT: 3-17-0059-B14
 IL PROJ.: C75-4218

AIRFIELD LIGHTING NOTES

1. UNLESS OTHERWISE NOTED, ALL UNDERGROUND AIRFIELD LIGHTING SERIES CIRCUIT CONDUCTORS WHETHER DEB OR IN DUCT/CONDUIT SHALL BE FAA APPROVED 5000 VOLT L-824 TYPE. ALL UNDERGROUND FIELD POWER LOW VOLTAGE (600 VOLT & BELOW) CIRCUIT CONDUCTORS WHETHER DEB OR IN DUCT/CONDUIT SHALL BE UL LISTED 600 VOLT, TYPE XLP-USE-2 COPPER CONDUCTORS. CONDUCTOR SIZES SHALL BE AS SPECIFIED, HEREIN.
2. NO COMPONENTS OF PRIMARY CIRCUIT SUCH AS CABLE, CONNECTORS AND TRANSFORMERS SHALL BE BROUGHT ABOVE GROUND AT EDGE LIGHTS, SIGNS, REIL, PAPI, ETC.
3. THERE SHALL BE NO EXPOSED POWER/CONTROL CABLES BETWEEN THE POINT WHERE THEY LEAVE THE UNDERGROUND (DEB OR L-867 BASES) AND WHERE THEY ENTER THE EQUIPMENT (SUCH AS TAXIWAY SIGNS, PAPI, REIL, ETC.) ENCLOSURES. THESE CABLES SHALL BE ENCLOSED IN RIGID CONDUIT OR IN FLEXIBLE, WATERTIGHT CONDUIT WITH BREAKABLE COUPLING(S) AT THE GRADE OR THE HOUSING COVER, AS SHOWN IN APPLICABLE DETAILS.
4. THE JOINTS OF THE L-823 PRIMARY CONNECTORS SHALL BE WRAPPED WITH AT LEAST ONE LAYER OF RUBBER OR SYNTHETIC RUBBER TAPE AND ONE LAYER OF PLASTIC TAPE, ONE-HALF LAPPED, EXTENDING AT LEAST 1-1/2 INCHES ON EACH SIDE OF THE JOINT, AS SHOWN ON ELECTRICAL DETAILS SHEET 1.
5. THE CABLE ENTRANCE INTO THE FIELD-ATTACHED L-823 CONNECTORS SHALL BE ENCLOSED BY A HEAT-SHRINKABLE TUBING WITH CONTINUOUS INTERNAL ADHESIVE, AS SHOWN ON ELECTRICAL DETAILS SHEET 1.
6. L-823 TYPE II, TWO-CONDUCTOR SECONDARY CONNECTORS SHALL BE CLASS 'A' (FACTORY MOLDED).
7. THERE SHALL BE NO SPLICES IN THE SECONDARY CABLE(S) WITHIN THE STEMS OF A RUNWAY/TAXIWAY EDGE/THRESHOLD LIGHTING FIXTURE AND THE WIREWAYS LEADING TO TAXIWAY SIGNS AND PAPI/REIL EQUIPMENT.
8. ELECTRICAL INSULATING GREASE SHALL BE APPLIED WITHIN THE L-823, SECONDARY, TWO CONDUCTOR CONNECTORS TO PREVENT WATER ENTRANCE. THESE CONNECTORS SHALL NOT BE TAPED.
9. DEB ISOLATION TRANSFORMERS SHALL BE BURIED AT A DEPTH OF TEN (10") INCHES ON A LINE CROSSING THE LIGHT AND PERPENDICULAR TO THE RUNWAY/TAXIWAY CENTERLINE AT A LOCATION TWELVE (12") INCHES FROM THE LIGHT OPPOSITE FROM THE RUNWAY/TAXIWAY.
10. A SLACK OF THREE (3') FEET, MINIMUM, PLUS DEPTH OF BASE CAN (IF APPLICABLE) SHALL BE PROVIDED IN THE PRIMARY CABLE AT EACH TRANSFORMER/CONNECTOR TERMINATION. AT STAKE-MOUNTED LIGHTS, THE SLACK SHALL BE LOOSELY COILED IMMEDIATELY BELOW THE ISOLATION TRANSFORMER. THERE SHALL BE NO ADDITIONAL PAYMENT FOR CABLE SLACK AND THEREFORE THE QUANTITY OF PROPOSED CABLE SLACK HAS NOT BEEN INCLUDED IN THE RESPECTIVE CABLE PAY ITEMS.
11. DIRECTION OF PRIMARY CABLES SHALL BE IDENTIFIED BY COLOR CODING AS FOLLOWS: WHEN FACING LIGHT WITH BACK TO PAVEMENT, CABLE TO THE LEFT IS CODED RED AND CABLE TO RIGHT IS CODED BLUE. THIS APPLIES TO STAKE MOUNTED LIGHTS AND BASE MOUNTED LIGHTS WHERE THE BASE HAS ONLY ONE ENTRANCE.
12. L-867 BASES SHALL BE SIZE B, 24" DEEP, CLASS I, UNLESS OTHERWISE NOTED.
13. BASE MOUNTED BREAKABLE COUPLINGS SHALL NOT HAVE WEEP HOLES TO THE OUTSIDE. PLUGGED UP HOLES SHALL NOT BE ACCEPTABLE. IT SHALL BE A 1/4" DIAMETER, MINIMUM, OR EQUIVALENT OPENING FOR DRAINAGE FROM THE SPACE AROUND THE SECONDARY CONNECTOR INTO THE L-867 BASE.
14. THE ELEVATION OF THE BREAKABLE COUPLING GROOVE SHALL NOT EXCEED 1-1/2" ABOVE THE EDGE OF THE COVER IN CASE OF BASE MOUNTED COUPLINGS, OR THE TOP OF THE STAKE IN CASE OF STAKE MOUNTED COUPLINGS.
15. WHERE THE BREAKABLE COUPLING IS NOT AN INTEGRAL PART OF THE LIGHT FIXTURE STEM OR MOUNTING LEG, A BEAD OF SILICON SEAL SHALL BE APPLIED COMPLETELY AROUND LIGHT STEM OR WIREWAY AT BREAKABLE COUPLING TO PROVIDE A WATERTIGHT SEAL.
16. TOPS OF THE STAKES SUPPORTING LIGHT FIXTURES SHALL BE FLUSH WITH THE SURROUNDING GRADE.
17. PLASTIC LIGHTING FIXTURE COMPONENTS, SUCH AS LAMP HEADS, STEMS, BREAKABLE COUPLINGS, BASE COVERS, BRACKETS, STAKES, SHALL NOT BE ACCEPTABLE.
18. THE TOLERANCE FOR THE HEIGHT OF RUNWAY/TAXIWAY EDGE LIGHTS SHALL BE: ONE (1) INCH. IN CASE OF STAKE MOUNTED LIGHTS, THE SPECIFIED LIGHTING FIXTURE HEIGHT SHALL BE MEASURED BETWEEN THE TOP OF THE STAKE AND THE TOP OF THE LENS. IN CASE OF BASE MOUNTED LIGHTS, THE SPECIFIED LIGHTING FIXTURE HEIGHT SHALL BE MEASURED BETWEEN THE TOP OF THE BASE FLANGE AND THE TOP OF THE LENS, THUS INCLUDING THE BASE COVER, THE FRANGIBLE COUPLING, THE STEM, THE LAMP HOUSING AND THE LENS.

19. THE TOLERANCE FOR THE LATERAL SPACING (LIGHT LANE TO RUNWAY/TAXIWAY CENTERLINE) OF RUNWAY/TAXIWAY EDGE LIGHTS SHALL BE ONE (1) INCH. THIS ALSO APPLIES AT INTERSECTIONS TO LATERAL SPACING BETWEEN LIGHTS OF A RUNWAY/TAXIWAY AND THE INTERSECTING RUNWAY/TAXIWAY.
20. ENTRANCES INTO L-867 BASES SHALL HAVE CONDUIT COUPLINGS OR REDUCERS TO INTERFACE UNIT DUCT/CONDUIT TO L-867 BASE HUBS, OR SHALL BE SEALED WITH HEAT SHRINK AS SHOWN IN DETAIL "B" ON ELECTRICAL DETAILS SHEET 1.
21. GALVANIZED/PAINTED EQUIPMENT/COMPONENT SURFACES SHALL NOT BE DAMAGED BY DRILLING, FILING, ETC. DRAIN HOLES IN METAL TRANSFORMER HOUSINGS SHALL BE MADE BEFORE GALVANIZING.
22. EDGE LIGHT NUMBERING TAGS SHALL BE FACING THE PAVEMENT.
23. CABLE/SPLICE/DUCT MARKERS SHALL BE PRECAST CONCRETE OF THE SIZE SHOWN. LETTERS/NUMBERS/ARROWS FOR THE LEGEND TO BE IMPRESSED INTO THE TOPS OF THE MARKERS SHALL BE PRE-ASSEMBLED AND SECURED IN THE MOLD BEFORE THE CONCRETE IS POURED. LEGEND INSCRIBED BY HAND IN WET CONCRETE SHALL NOT BE ACCEPTABLE.
24. ALL UNDERGROUND CABLE RUNS SHALL BE IDENTIFIED BY CABLE MARKERS AT 200 FEET MAXIMUM SPACING, WITH AN ADDITIONAL MARKER AT EACH CHANGE OF DIRECTION OF THE CABLE RUN. CABLE MARKERS SHALL BE INSTALLED IMMEDIATELY ABOVE THE CABLES.
25. THERE SHALL BE NO SPLICES BETWEEN THE ISOLATION TRANSFORMERS. L-823 CONNECTORS ARE ALLOWED AT TRANSFORMER CONNECTIONS ONLY, UNLESS OTHERWISE SHOWN.
26. APPLY AN OXIDE INHIBITING, ANTI-SEIZING COMPOUND TO ALL SCREWS, NUTS AND BREAKAGE COUPLING THREADS.
27. LOCATIONS OF ENDS OF ALL UNDERGROUND DUCTS SHALL BE IDENTIFIED BY DUCT MARKERS.
28. WHERE A PARALLEL, CONSTANT VOLTAGE PAPI SYSTEM IS PROVIDED, THE "T" SPLICES SHALL BE OF THE CAST TYPE.
29. CONCRETE USED FOR SLABS, FOOTINGS, BACKFILL AROUND TRANSFORMER HOUSINGS, MARKINGS, ETC. SHALL BE 3500 PSI, AIR-ENTRAINED.
30. ALL POWER AND CONTROL CABLES IN MAN/HAND HOLES SHALL BE TAGGED. USE EMBOSSED COPPER STRIPS TO BE ATTACHED AT BOTH ENDS TO THE CABLE BY THE USE OF PLASTIC STRAPS. MINIMUM OF TWO TAGS SHALL BE PROVIDED ON EACH CABLE IN A MAN/HAND HOLE-ONE AT THE CABLE ENTRANCE AND ONE AT THE CABLE EXIT.
31. THE LOCATION, SIZE AND TYPE OF MATERIAL OF EXISTING UNDERGROUND AND/OR ABOVEGROUND UTILITIES INDICATED ON THE PLANS IS NOT REPRESENTED AS BEING ACCURATE, SUFFICIENT OR COMPLETE. NEITHER THE OWNER NOR THE ENGINEER ASSUMES ANY RESPONSIBILITY WHATEVER IN RESPECT TO ACCURACY, COMPLETENESS, OR SUFFICIENCY OF THE INFORMATION. THERE IS NO GUARANTEE EITHER EXPRESSED OR IMPLIED, THAT THE LOCATIONS, SIZE AND TYPE OF MATERIAL OF EXISTING UNDERGROUND UTILITIES INDICATED ARE REPRESENTATIVE OF THOSE TO BE ENCOUNTERED IN THE CONSTRUCTION. IT SHALL BE THE CONTRACTOR'S RESPONSIBILITY TO DETERMINE THE ACTUAL LOCATION OF ALL SUCH FACILITIES, INCLUDING SERVICE CONNECTIONS TO UNDERGROUND UTILITIES. PRIOR TO CONSTRUCTION, THE CONTRACTOR SHALL NOTIFY THE UTILITY COMPANIES OF HIS OPERATIONAL PLANS AND SHALL OBTAIN FROM THE RESPECTIVE UTILITY COMPANIES DETAILED INFORMATION AND ASSISTANCE RELATIVE TO THE LOCATION OF THEIR FACILITIES AND THE WORKING SCHEDULE OF THE COMPANIES FOR REMOVAL OR ADJUSTMENT WHERE REQUIRED. IN THE EVENT AN UNEXPECTED UTILITY INTERFERENCE IS ENCOUNTERED DURING CONSTRUCTION, THE CONTRACTOR SHALL IMMEDIATELY NOTIFY THE UTILITY COMPANY OF JURISDICTION. THE OWNER'S REPRESENTATIVE AND/OR THE RESIDENT ENGINEER SHALL ALSO BE IMMEDIATELY NOTIFIED. ANY DAMAGE TO SUCH MAINS AND SERVICES SHALL BE RESTORED TO SERVICE AT ONCE AND PAID FOR BY THE CONTRACTOR AT NO ADDITIONAL COST TO THE CONTRACT. ALL UTILITY CABLES AND LINES SHALL BE LOCATED BY THE RESPECTIVE UTILITY. **CONTACT JULIE (JOINT UTILITY LOCATION INFORMATION FOR EXCAVATORS) FOR UTILITY INFORMATION, PHONE: 1-800-892-0123.** CONTACT THE FAA (FEDERAL AVIATION ADMINISTRATION) FOR ASSISTANCE IN LOCATING FAA CABLES AND UTILITIES. LOCATION OF FAA POWER, CONTROL AND COMMUNICATION CABLES SHALL BE COORDINATED WITH AND/OR LOCATED BY THE FAA. ALSO CONTACT AIRPORT DIRECTOR/MANAGER AND AIRPORT PERSONNEL FOR ASSISTANCE IN LOCATING UNDERGROUND AIRPORT CABLES AND/OR UTILITIES. ALSO COORDINATE WORK WITH ALL ABOVE GROUND UTILITIES.
32. WHEN PREPARING CABLE FOR SPLICES, THE CONTRACTOR SHALL USE A CABLE STRIPPER/PENCILLER WHENEVER CABLE CONNECTIONS ARE MADE.

GROUNDING NOTES FOR AIRFIELD LIGHTING

1. GROUNDING FOR RUNWAY LIGHTS, TAXIWAY LIGHTS, AND LIGHTED TAXI GUIDANCE SIGNS SHALL BE AS DETAILED ON THE PLANS AND AS SPECIFIED HEREIN. PER FAA AC 150/5340-30G DESIGN AND INSTALLATION DETAILS FOR AIRPORT VISUAL AIDS, CHAPTER 12, PART 12.6; A GROUND MUST BE INSTALLED AT EACH LIGHT FIXTURE. THE PURPOSE OF THE LIGHT BASE GROUND IS TO PROVIDE A DEGREE OF PROTECTION FOR MAINTENANCE PERSONNEL FROM POSSIBLE CONTACT WITH AN ENERGIZED LIGHT BASE OR MOUNTING STAKE THAT MAY RESULT FROM A SHORTED POWER CABLE OR ISOLATION TRANSFORMER. A LIGHT BASE GROUND SHALL BE INSTALLED AT EACH TRANSFORMER BASE/LIGHT CAN ASSOCIATED WITH RUNWAY LIGHTS, TAXIWAY LIGHTS, AND LIGHTED TAXI GUIDANCE SIGNS. A LIGHT BASE GROUND SHALL ALSO BE INSTALLED AT EACH STAKE MOUNTED LIGHT FIXTURE. A LIGHT BASE GROUND SHALL BE INSTALLED AND CONNECTED TO THE METAL FRAME OF EACH TAXI GUIDANCE SIGN AS DETAILED ON THE PLANS AND IN ACCORDANCE WITH THE RESPECTIVE TAXI GUIDANCE SIGN MANUFACTURER RECOMMENDATIONS. THE LIGHT BASE GROUND SHALL BE A #6 AWG BARE COPPER CONDUCTOR CONNECTED TO THE GROUND LUG ON THE RESPECTIVE L-867 TRANSFORMER BASE/LIGHT CAN OR MOUNTING STAKE AND A 3/4-INCH DIAMETER BY 20-FOOT LONG (MINIMUM) UL LISTED COPPER CLAD GROUND ROD (TWO 3/4-INCH DIAMETER BY 10-FOOT LONG, UL LISTED COPPER CLAD GROUND RODS COUPLED TOGETHER). 20-FOOT LONG GROUND RODS ARE REQUIRED DUE TO POOR RESISTANCE OF THE SOIL AT THE RESPECTIVE SITE. CONNECTIONS TO GROUND LUGS ON THE L-867 TRANSFORMER BASE/LIGHT CAN OR MOUNTING STAKE SHALL BE WITH A UL LISTED GROUNDING CONNECTOR. CONNECTIONS TO GROUND RODS SHALL BE MADE WITH EXOTHERMIC WELD TYPE CONNECTORS, CADWELD BY ERICO PRODUCTS, INC., SOLON, OHIO, (PHONE: 800-248-9353), THERMOWELD BY CONTINENTAL INDUSTRIES, INC., TULSA, OKLAHOMA (PHONE: 918-663-1440), ULTRAWELD BY HARGER, GRAYSLAKE, ILLINOIS (PHONE: 800-842-7437), OR APPROVED EQUAL. EXOTHERMIC WELD CONNECTIONS SHALL BE INSTALLED IN CONFORMANCE WITH THE RESPECTIVE MANUFACTURER'S DIRECTIONS USING MOLDS AS REQUIRED FOR EACH RESPECTIVE APPLICATION. BOLTED CONNECTIONS WILL NOT BE PERMITTED AT GROUND RODS. TOP OF GROUND RODS SHALL BE BURIED 30 INCHES MINIMUM BELOW GRADE, UNLESS SPECIFIED OTHERWISE HEREIN, FOR RESPECTIVE APPLICATIONS.
2. FURNISH AND INSTALL A #6 AWG BARE SOLID COPPER GROUND AND BOND IT TO EACH GROUND ROD AT THE RESPECTIVE AIRFIELD LIGHT FIXTURES AND TAXI GUIDANCE SIGNS. THE #6 AWG GROUND SHALL BE DIRECT BURIAL IN TRENCH APPROXIMATELY 12 TO 18 INCHES BELOW BELOW GRADE. THE GROUND CONDUCTOR MAY BE INSTALLED ABOVE THE #8 FAA L-824, 5000-VOLT CABLE IN UNIT DUCT OR IN AN ADJACENT TRENCH. THE #6 AWG GROUND SHALL BE CONNECTED TO EACH RESPECTIVE GROUND ROD WITH AND EXOTHERMIC WELD CONNECTION. THE COMPLETED GROUND WIRE INSTALLED WILL PROVIDE A GROUND RING SYSTEM FOR THE RESPECTIVE AIRFIELD LIGHTING CIRCUIT. THE GROUND WIRE WILL NOT BE INSTALLED WITH THE HOMERUN CABLES FOR TH#6 AWG BARE SOLID COPPER GROUND WILL BE PAID FOR UNDER ITEM AR108756 1/C #6 GROUND PER LINEAR FOOT.
3. FOR BASE MOUNTED LIGHT FIXTURES THE LIGHT FIXTURE MUST BE BONDED TO THE LIGHT BASE INTERNAL GROUND LUG VIA A #6 AWG STRANDED COPPER WIRE RATED FOR 600 VOLTS WITH GREEN XHHW OR USE INSULATION. THE GROUND WIRE LENGTH MUST BE SUFFICIENT TO ALLOW THE REMOVAL OF THE LIGHT FIXTURE FROM THE LIGHT BASE FOR ROUTING MAINTENANCE. SEE THE LIGHT FIXTURE MANUFACTURER'S INSTRUCTIONS FOR PROPER METHODS OF ATTACHING BONDING WIRE.
4. CLEAN ALL METAL SURFACES BEFORE MAKING GROUND CONNECTIONS. METALLIC SURFACES TO BE JOINED SHALL BE PREPARED BY THE REMOVAL OF ALL NON-CONDUCTIVE MATERIAL PER 2011 NATIONAL ELECTRICAL CODE ARTICLE 250-12.
5. PER FAA 150/5340-30G THE RESISTANCE TO GROUND OF THE RESPECTIVE MOUNTING STAKE OR LIGHT BASE (WITH GROUND ROD CONNECTED) MUST BE 25 OHMS OR LESS.
6. FOR RUNWAY THRESHOLD LIGHTS THAT ARE SPACED WITH 10 FEET OF SEPARATION BETWEEN THEM, PROVIDE ONE 3/4-INCH DIAMETER BY 20-FOOT LONG GROUND ROD PER TWO ADJACENT THRESHOLD LIGHTS. LOCATE GROUND ROD MIDWAY BETWEEN THE TWO THRESHOLD LIGHTS.
7. FOR TAXIWAY LIGHTS THAT ARE SPACED WITH LESS THAN 20 FEET OF SEPARATION BETWEEN THEM, PROVIDE ONE 3/4-INCH DIAMETER BY 20 FEET LONG GROUND ROD PER TWO ADJACENT TAXIWAY LIGHTS. LOCATE GROUND ROD MIDWAY BETWEEN THE TWO TAXIWAY LIGHTS.
8. FOR EACH AIRFIELD LIGHT FIXTURE, TAXI GUIDANCE SIGN, AND NAVAID THE CONTRACTOR SHALL TEST THE MADE ELECTRODE GROUND SYSTEM WITH AN INSTRUMENT SPECIFICALLY DESIGN FOR TESTING GROUND SYSTEMS. TEST RESULT SHALL BE RECORDED FOR EACH AIRFIELD LIGHT FIXTURE, TAXI GUIDANCE SIGN, AND NAVAIDS INSTALLATION. IF GROUND RESISTANCE EXCEEDS 25 OHMS, CONTACT THE PROJECT ENGINEER FOR FURTHER DIRECTION. COPIES OF THE GROUND SYSTEM TEST RESULTS SHALL BE FURNISHED TO THE PROJECT ENGINEER.

JAN 11, 2013 1:20 PM HARR01115 p:\s\spi-svr306\hanson\Projects\Documents\09a\031\09a0031\09a0031\09a0031.dwg\Report\Sheet\E-002-NOTE

REVISION					
DATE					
MARSHALL COUNTY AIRPORT LACON, ILLINOIS					
BLOCK GRANT: 3-17-0059-B14					
IL PROJ.: C75-4218					
Hanson Project No. 09A0031	E-002-NOTE.dwg	NOT TO SCALE	01/11/13	KWL 08/16/12	BSS 01/11/13
Filename	Scale	Date	LAYOUT	DRAWN	REVIEWED
					
© Copyright Hanson Professional Services Inc. 2012 Hanson Professional Services Inc. 1625 So. Main Street Springfield, Illinois 62703-2886					
CONSTRUCT A 2.065' X 35' PARTIAL PARALLEL TAXIWAY TO RUNWAY 13/31			ELECTRICAL NOTES SHEET 2		
60					
60 of 79 sheets					

ELECTRICAL LEGEND - ONE-LINE DIAGRAM	
	CABLE TERMINATOR/LUG
	TRANSFORMER
	DISCONNECT SWITCH
	FUSIBLE DISCONNECT SWITCH
	CIRCUIT BREAKER
	THERMAL MAGNETIC CIRCUIT BREAKER
	FUSE
	TRANSIENT VOLTAGE SURGE SUPPRESSOR OR SURGE PROTECTOR DEVICE
	GROUND - GROUND ROD, GROUNDING ELECTRODE, OR AT EARTH POTENTIAL
	INDICATING LIGHT
	MOTOR
	LOAD, MOTOR, # = HORSEPOWER
	ELECTRIC UTILITY METER BASE
	JUNCTION BOX WITH SPLICE
	EQUIPMENT, XXX = DEVICE DESCRIPTION
	GROUND BUS OR TERMINAL
	NEUTRAL BUS
	PANELBOARD WITH MAIN LUGS
	PANELBOARD WITH MAIN BREAKER
	FUSE PANEL WITH MAIN FUSE PULLOUT
	DUPLEX RECEPTACLE 120V SINGLE PHASE GROUNDING TYPE
	CONTROL STATION
	TRANSFER SWITCH
	ENGINE GENERATOR SET

ELECTRICAL LEGEND - SCHEMATIC	
	NORMALLY OPEN (N.O.) CONTACT
	NORMALLY CLOSED (N.C.) CONTACT
	STARTER COIL, * = STARTER NUMBER
	OVERLOAD RELAY CONTACT
	CONTROL RELAY, * = CONTROL RELAY NUMBER
	RELAY, * = RELAY NUMBER
	TOGGLE SWITCH / 2 POSITION SWITCH
	2-POSITION SELECTOR SWITCH
	3-POSITION SELECTOR SWITCH (H-O-A SHOWN)
	2 POLE DISCONNECT SWITCH
	3 POLE DISCONNECT SWITCH
	PHOTOCELL
	TERMINAL BLOCK, * = TERMINAL NUMBER
	DEVICE TERMINAL, * = DEVICE TERMINAL NUMBER
	INTERNAL PANEL WIRING
	FIELD WIRING
	FUSE
	GROUND BUS OR TERMINAL
	NEUTRAL BUS
	GROUND, GROUND ROD, GROUND BUS
	INDUSTRIAL CONTROL RELAY OR LIGHTING CONTACTOR
	S1 CUTOUT HANDLE REMOVED
	S1 CUTOUT HANDLE INSERTED
	N.O. THERMAL SWITCH
	N.C. THERMAL SWITCH
	L-830 SERIES ISOLATION TRANSFORMER

ELECTRICAL ABBREVIATIONS	
A.F.F.	ABOVE FINISHED FLOOR
A, AMP	AMPERES
ATS	AUTOMATIC TRANSFER SWITCH
AWG	AMERICAN WIRE GAUGE
BKR	BREAKER
C	CONDUIT
CB	CIRCUIT BREAKER
CKT	CIRCUIT
CR	CONTROL RELAY
CU	COPPER
DPDT	DOUBLE POLE DOUBLE THROW
DPST	DOUBLE POLE SINGLE THROW
EM	EMERGENCY
EMT	ELECTRICAL METALLIC TUBING
ENCL	ENCLOSURE
EP	EXPLOSION PROOF
ES	EMERGENCY STOP
ETL	INTERTEK - ELECTRICAL TESTING LABS
ETM	ELAPSE TIME METER
GFCI	GROUND FAULT CIRCUIT INTERRUPTER
GFI	GROUND FAULT INTERRUPTER
GND	GROUND
GRSC	GALVANIZED RIGID STEEL CONDUIT
HID	HIGH INTENSITY DISCHARGE
HOA	HAND OFF AUTOMATIC
HP	HORSEPOWER
HPS	HIGH PRESSURE SODIUM
J	JUNCTION BOX
KVA	KILOVOLT AMPERE(S)
KW	KILOWATTS
LC	LIGHTING CONTACTOR
LTFMC	LIQUID TIGHT FLEXIBLE METAL CONDUIT (UL LISTED)
LTG	LIGHTING
LP	LIGHTING PANEL
MAX	MAXIMUM
MCB	MAIN CIRCUIT BREAKER
MCM	THOUSAND CIRCUAR MIL
MDP	MAIN DISTRIBUTION PANEL
MFR	MANUFACTURER
MH	METAL HALIDE
MIN	MINIMUM
MLO	MAIN LUGS ONLY
NEC	NATIONAL ELECTRICAL CODE (NFPA 70)
NC	NORMALLY CLOSED
NO	NORMALLY OPEN
NTS	NOT TO SCALE
OHE	OVERHEAD ELECTRIC
OL	OVERLOAD

ELECTRICAL ABBREVIATIONS (CONTINUED)	
PB	PULL BOX
PC	PHOTO CELL
PDB	POWER DISTRIBUTION BLOCK
PNL	PANEL
RCPT	RECEPTACLE
R	RELAY
S	STARTER
SPD	SURGE PROTECTION DEVICE
SPST	SINGLE POLE SINGLE THROW
TVSS	TRANSIENT VOLTAGE SURGE SUPPRESSOR
TYP	TYPICAL
UG	UNDERGROUND
UGE	UNDERGROUND ELECTRIC
UL	UNDERWRITER'S LABORATORIES
V	VOLTS
W/	WITH
W/O	WITHOUT
WP	WEATHER PROOF
XFER	TRANSFER
XFMR	TRANSFORMER

AIRPORT EQUIPMENT/FACILITY ABBREVIATIONS	
ASOS	AUTOMATED SURFACE OBSERVING SYSTEM
ATCT	AIR TRAFFIC CONTROL TOWER
AWOS	AUTOMATED WEATHER OBSERVING SYSTEM
CCR	CONSTANT CURRENT REGULATOR
DME	DISTANCE MEASURING EQUIPMENT
FAR	FEDERAL AVIATION REGULATION
GS	GLIDE SLOPE FACILITY
HIRL	HIGH INTENSITY RUNWAY LIGHT
ILS	INSTRUMENT LANDING SYSTEM
IM	INNER MARKER
LIR	LOW IMPACT-RESISTANT
LOC	LOCALIZER FACILITY
MALS	MEDIUM INTENSITY APPROACH LIGHTING SYSTEM
MALSR	MEDIUM INTENSITY APPROACH LIGHTING SYSTEM WITH RUNWAY ALIGNMENT INDICATING LIGHTS
MIRL	MEDIUM INTENSITY RUNWAY LIGHT
MITL	MEDIUM INTENSITY TAXIWAY LIGHT
NDB	NON-DIRECTIONAL BEACON
PAPI	PRECISION APPROACH PATH INDICATOR
PLASI	PULSE LIGHT APPROACH SLOPE INDICATOR
RAIL	RUNWAY ALIGNMENT INDICATING LIGHTS
REIL	RUNWAY END IDENTIFIER LIGHT
RVR	RUNWAY VISUAL RANGE
VADI	VISUAL APPROACH DESCENT INDICATOR
VASI	VISUAL APPROACH SLOPE INDICATOR
VOR	VERY HIGH FREQUENCY OMNIDIRECTIONAL RANGE FACILITY
WC	WIND CONE

NOTES:

- ALL ELECTRICAL EQUIPMENT SHALL BE INSTALLED IN CONFORMANCE WITH NFPA 70 - NATIONAL ELECTRICAL CODE (NEC) MOST CURRENT ISSUE IN FORCE, THE RESPECTIVE EQUIPMENT MANUFACTURER'S DIRECTIONS AND ALL OTHER APPLICABLE LOCAL CODES, LAWS, ORDINANCES, AND REQUIREMENTS IN FORCE. ANY INSTALLATIONS WHICH VOID THE U.L. LISTING, ETL LISTING (OR OTHER THIRD PARTY LISTING) AND/OR THE MANUFACTURER'S WARRANTY OF A DEVICE WILL NOT BE PERMITTED.
- ALL VAULT WORK, POWER OUTAGES, AND/OR SHUT DOWN OF EXISTING SYSTEMS SHALL BE COORDINATED WITH THE AIRPORT MANAGER. ONCE SHUT DOWN, THE CIRCUITS SHALL BE LABELED AS SUCH TO PREVENT ACCIDENTAL ENERGIZING OF THE RESPECTIVE CIRCUITS. ALL PERSONNEL SHALL FOLLOW U.S. DEPARTMENT OF LABOR OCCUPATIONAL SAFETY & HEALTH ADMINISTRATION (OSHA) 29 CFR PART 1910 OCCUPATIONAL SAFETY & HEALTH STANDARDS FOR ELECTRICAL SAFETY AND LOCKOUT/TAGOUT PROCEDURES INCLUDING, BUT NOT LIMITED TO, 29 CFR SECTION 1910.147 THE CONTROL OF HAZARDOUS ENERGY (LOCKOUT/TAGOUT).
- COLOR CODE PHASE AND NEUTRAL CONDUCTOR INSULATION FOR NO. 6 AWG OR SMALLER. PROVIDE COLORED INSULATION OR COLORED MARKING TAPE FOR PHASE AND NEUTRAL CONDUCTORS FOR NO. 4 AWG AND LARGER. INSULATED GROUND CONDUCTORS SHALL HAVE GREEN COLORED INSULATION FOR ALL CONDUCTOR AWG AND/OR KCMIL TO COMPLY WITH NEC 250.119. NEUTRAL CONDUCTORS SHALL HAVE WHITE COLORED INSULATION FOR NO. 6 AWG AND SMALLER TO MEET THE REQUIREMENTS OF NEC 200.6. STANDARD COLORS FOR POWER WIRING AND BRANCH CIRCUITS SHALL BE AS FOLLOWS:

120/240 VAC, 1 PHASE, 3 WIRE	
PHASE A	BLACK
PHASE B	RED
NEUTRAL	WHITE
GROUND	GREEN
- SEE RESPECTIVE SITE PLANS FOR SITE LEGEND INFORMATION.
- LTFMC DENOTES LIQUID TIGHT FLEXIBLE METAL CONDUIT UL LISTED, SUNLIGHT RESISTANT, & SUITABLE FOR GROUNDING. LIQUID TIGHT FLEXIBLE METAL CONDUIT AND ASSOCIATED FITTINGS SHALL BE U.L. LISTED TO MEET THE REQUIREMENTS OF NEC 350.6. LIQUID TIGHT FLEXIBLE METAL CONDUIT THAT IS USED FOR FLEXIBILITY (INCLUDING CONNECTIONS TO CCR'S & TRANSFORMERS) SHALL REQUIRE AN EXTERNAL BONDING JUMPER OR INTERNAL EQUIPMENT GROUNDING CONDUCTOR PER NEC 350.60. EXTERNAL BONDING JUMPERS USED WITH CCR INSTALLATIONS SHALL BE #6 AWG COPPER (MINIMUM). DO NOT INSTALL LTFMC THAT IS NOT UL LISTED. CONFIRM LTFMC BEARS THE UL LABEL PRIOR TO INSTALLATION.
- ALL ENCLOSURES RATED NEMA 4, 4X SHALL HAVE WATERTIGHT HUBS AT CONDUIT ENTRANCES UL LISTED NEMA 4, 4X FOR THE RESPECTIVE ENCLOSURE, TO MAINTAIN THE NEMA 4, 4X RATING.
- HIGH VOLTAGE AND LOW VOLTAGE CIRCUITS SHALL NOT BE INSTALLED IN THE SAME WIREWAY, CONDUIT, DUCT, OR HANDHOLE.

REVISION					
DATE					
MARSHALL COUNTY AIRPORT LACON, ILLINOIS					
BLOCK GRANT: 3-17-0059-B14 IL PROJ.: C75-4218					
Hanson Project No.	09A0031	LAYOUT	KNL	08/16/12	
Filename	E-003-LEGN.dwg	DRAWN	BAK	08/16/12	
Scale	NOT TO SCALE	REVIEWED	BSS	01/11/13	
Date	01/11/13				
 © Copyright Hanson Professional Services Inc. 2012 Hanson Professional Services Inc. 1425 South Main Street Springfield, Illinois 62703-2886					
CONSTRUCT A 2,065' X 35' PARTIAL PARALLEL TAXIWAY TO RUNWAY 13/31			ELECTRICAL LEGEND AND ABBREVIATIONS		
61 61 of 79 sheets					

NOTES

- CONTRACTOR SHALL EXAMINE THE SITE TO FIELD VERIFY EXISTING CONDITIONS
- ALL VAULT WORK, POWER OUTAGES, AND/OR SHUT DOWN OF EXISTING SYSTEMS SHALL BE COORDINATED WITH THE AIRPORT MANAGER AND/OR AIRPORT REPRESENTATIVE. ONCE SHUT DOWN, THE CIRCUITS SHALL BE LABELED AS SUCH TO PREVENT ACCIDENTAL ENERGIZING OF THE RESPECTIVE CIRCUITS. ALL PERSONNEL SHALL FOLLOW U.S. DEPARTMENT OF LABOR OCCUPATIONAL SAFETY & HEALTH ADMINISTRATION (OSHA) 29 CFR PART 1910 OCCUPATIONAL SAFETY & HEALTH STANDARDS FOR ELECTRICAL SAFETY AND LOCKOUT/TAGOUT PROCEDURES INCLUDING, BUT NOT LIMITED TO, 29 CFR SECTION 1910.147 THE CONTROL OF HAZARDOUS ENERGY (LOCKOUT/TAGOUT).
- SEE "ELECTRICAL LEGEND AND ABBREVIATIONS" SHEET FOR GENERAL NOTES AND REQUIREMENTS.
- ALL EXISTING AIRFIELD LIGHTING SYSTEMS, NAVAIDS, STREET LIGHTING, AND/OR OTHER AIRPORT FACILITIES (THAT ARE NOT SCHEDULED FOR REMOVAL OR REPLACEMENT) SHALL BE OPERABLE DURING NIGHTFALL WHEN THE RUNWAY IS OPEN FOR OPERATION UNLESS OTHERWISE APPROVED BY THE AIRPORT MANAGER AND/OR OTHERWISE DETAILED HEREIN. CONTRACTOR SHALL PROVIDE ALL TEMPORARY WORK AS NECESSARY TO MAINTAIN OPERATION OF THE AIRFIELD LIGHTING SYSTEMS AT NIGHTFALL. CONTRACTOR SHALL COORDINATE TRANSFER OF EXISTING AIRFIELD CIRCUITS TO MINIMIZE DOWNTIME.
- EQUIPMENT DESIGNATED FOR REMOVAL SHALL BE TURNED OVER TO THE AIRPORT. IN THE EVENT THE AIRPORT DOES NOT WANT THE RESPECTIVE EQUIPMENT, THE CONTRACTOR SHALL DISPOSE OF IT OFF SITE AT NO ADDITIONAL COST TO THE CONTRACT.
- REMOVAL OF EXISTING VAULT AND EQUIPMENT WILL BE PAID FOR UNDER ITEM AR109901, REMOVE ELECTRICAL VAULT, PER LUMP SUM.

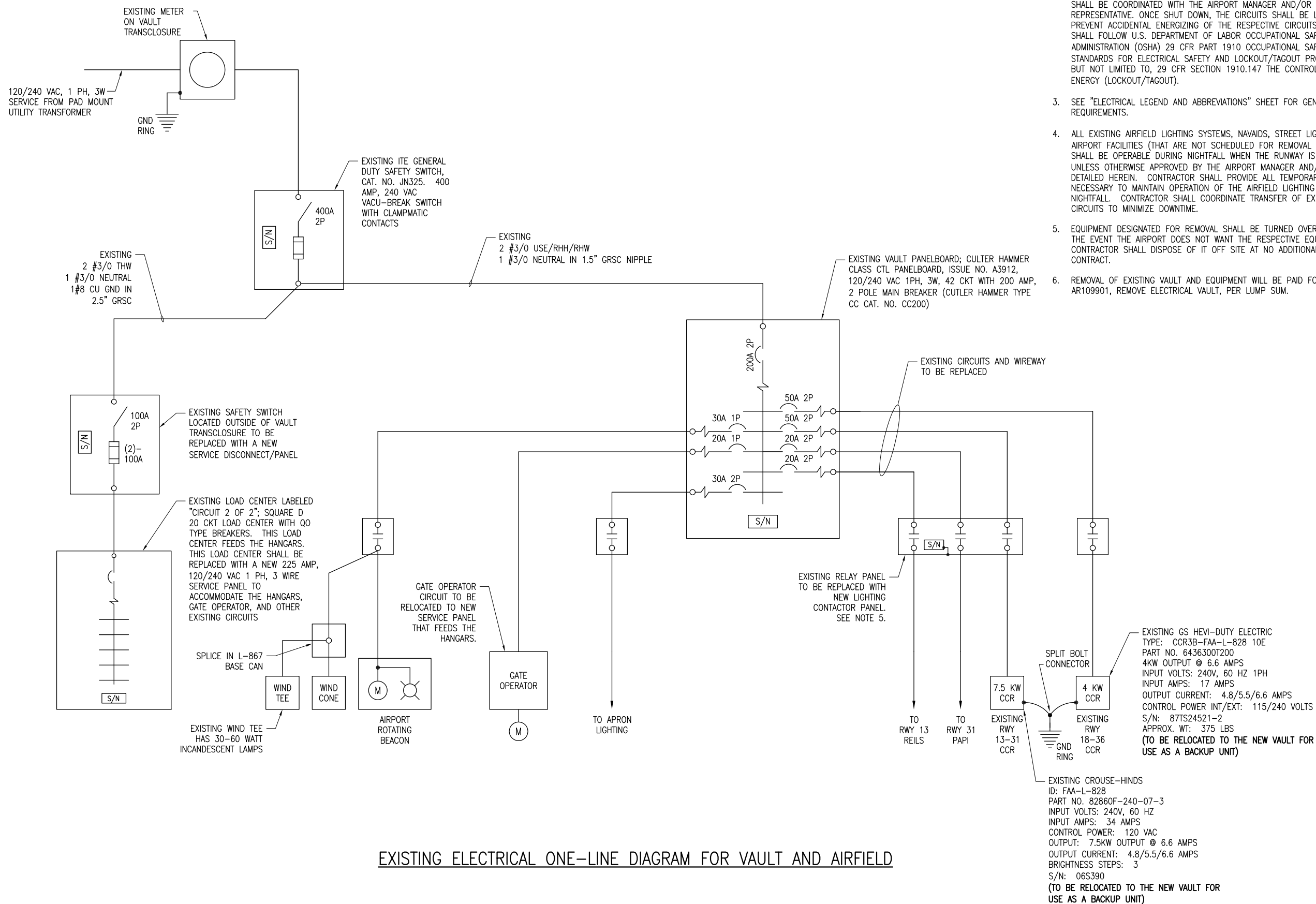

EXISTING ELECTRICAL ONE-LINE DIAGRAM FOR VAULT AND AIRFIELD

REVISION	
DATE	
MARSHALL COUNTY AIRPORT LACON, ILLINOIS	
BLOCK GRANT: 3-17-0059-B14	
IL PROJ.: C75-4218	

Hanson Project No.	09A0031
Filename	E-601-LINE.dwg
Scale	NOT TO SCALE
Date	01/11/13
LAYOUT	KNL 11/10/12
DRAWN	MLH 11/11/12
REVIEWED	BSS 01/11/13



CONSTRUCT A 2,065' X 35' PARTIAL PARALLEL TAXIWAY TO RUNWAY 13/31

EXISTING ELECTRICAL ONE-LINE DIAGRAM FOR VAULT AND AIRFIELD

JAN 11, 2013 1:20 PM HARR01115 p:\s\spi-svr306\hanson\Documents\09\Jobs\09A0031\09A0031D\CAD\Airport\Sheet\E-601-LINE

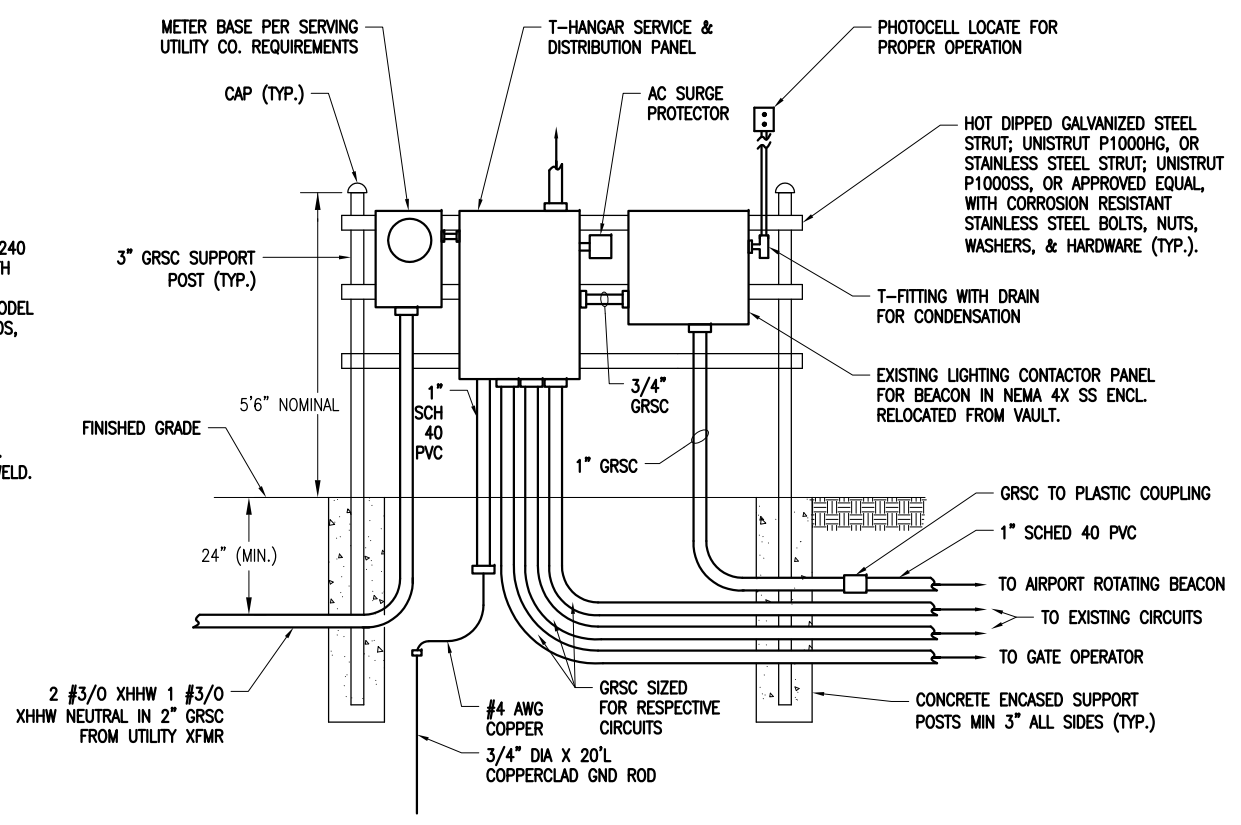
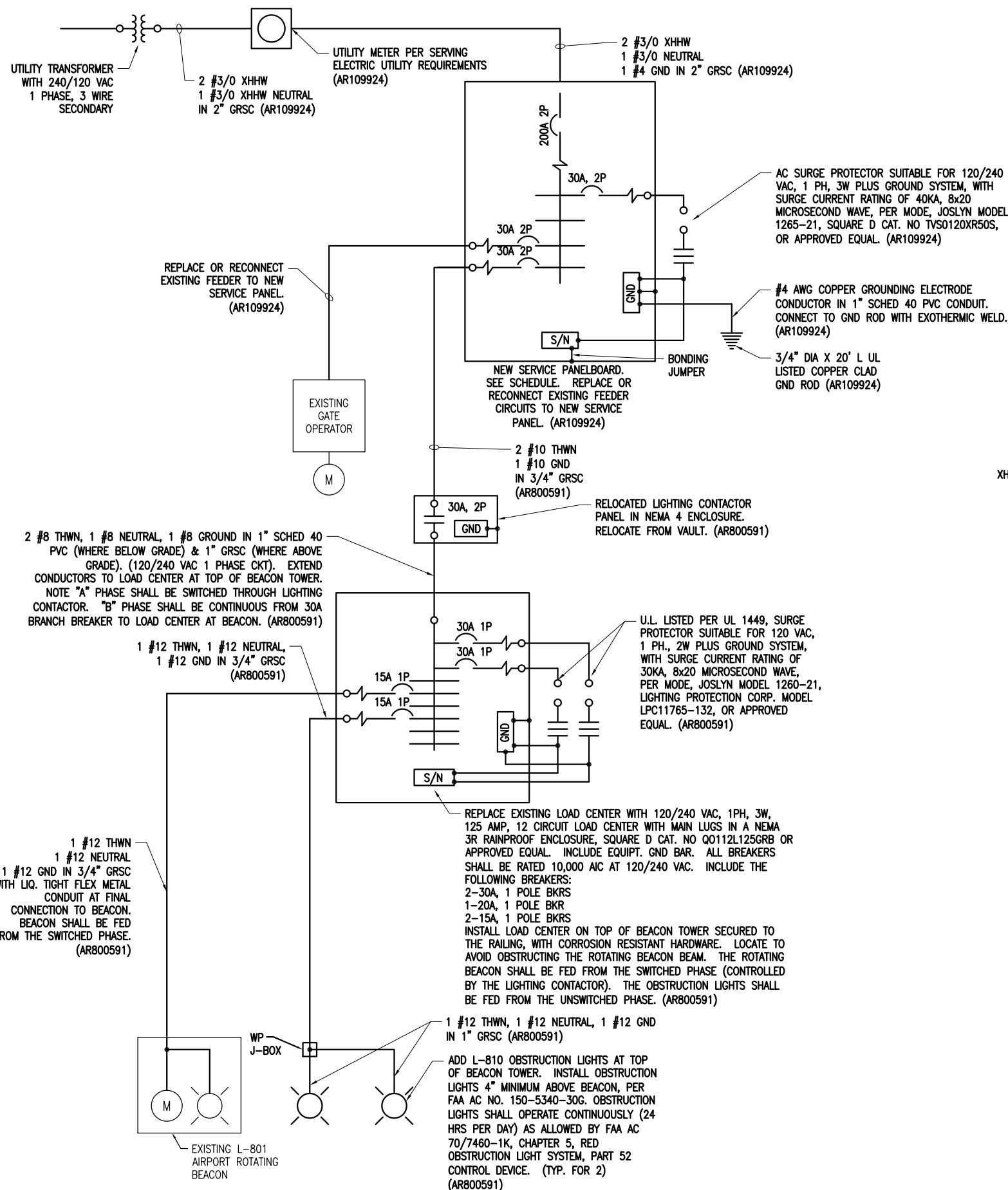

SERVICE ENTRANCE ELEVATION
NOT TO SCALE

NOTES

- ALL WORK, POWER OUTAGES, AND/OR SHUT DOWN OF EXISTING SYSTEMS SHALL BE COORDINATED WITH THE AIRPORT MANAGER. ONCE SHUT DOWN, THE CIRCUITS SHALL BE LABELED AS SUCH TO PREVENT ACCIDENTAL ENERGIZING OF THE RESPECTIVE CIRCUITS. ALL PERSONNEL SHALL FOLLOW U.S. DEPARTMENT OF LABOR OCCUPATIONAL SAFETY & HEALTH ADMINISTRATION (OSHA) 29 CFR PART 1910 OCCUPATIONAL SAFETY & HEALTH STANDARDS FOR ELECTRICAL SAFETY AND LOCKOUT/TAGOUT PROCEDURES INCLUDING, BUT NOT LIMITED TO, 29 CFR SECTION 1910.147 THE CONTROL OF HAZARDOUS ENERGY (LOCKOUT/TAGOUT).
- ALL ELECTRICAL EQUIPMENT SHALL BE INSTALLED IN CONFORMANCE WITH NFPA 70 - NATIONAL ELECTRICAL CODE (NEC) MOST CURRENT ISSUE IN FORCE, THE RESPECTIVE EQUIPMENT MANUFACTURER'S DIRECTIONS AND ALL OTHER APPLICABLE LOCAL CODES, LAWS, ORDINANCES AND REQUIREMENTS IN FORCE. ANY INSTALLATIONS WHICH VOID THE U.L. LISTING, ETL LISTING, (OR OTHER THIRD PARTY LISTING) AND/OR THE MANUFACTURER'S WARRANTY OF A DEVICE WILL NOT BE PERMITTED.
- ALL CONDUCTORS/WIRING SHALL BE COPPER.
- CONTRACTOR SHALL COORDINATE NEW ELECTRICAL SERVICE WITH THE SERVING ELECTRIC UTILITY AND THE AIRPORT MANAGER. CONTRACTOR SHALL CONFIRM REQUIREMENTS WITH SERVING ELECTRIC UTILITY COMPANY. THE SERVING ELECTRIC UTILITY IS AMEREN. PHONE 1-888-672-5252
- ELECTRICAL SERVICE PANELBOARD & GATE OPERATOR WORK SHOWN ON THIS SHEET SHALL BE PAID FOR UNDER ITEM AR109924 REPLACE ELECTRICAL SERVICES, PER LUMP SUM.
- WORK ASSOCIATED WITH THE AIRPORT ROTATING BEACON UPGRADE WILL BE PAID FOR UNDER ITEM AR800591 UPGRADE AIRPORT ROTATING BEACON PER LUMP SUM
- CONDUIT ENTRIES INTO NEMA 4, 4X ENCLOSURES SHALL HAVE NEMA 4, 4X HUBS TO MAINTAIN THE NEMA 4, 4X RATING OF THE ENCLOSURE.

PROPOSED ELECTRICAL ONE LINE DIAGRAM FOR T-HANGAR SERVICE PANEL

REVISION				
DATE				
MARSHALL COUNTY AIRPORT LACON, ILLINOIS				
BLOCK GRANT: 3-17-0059-B14 IL PROJ.: C75-4218				
Hanson Project No.	09A0031	LAYOUT	KNL	11/10/12
Filename	E-602-LIN.dwg	DRAWN	MLH	11/23/12
Scale	NOT TO SCALE	REVIEWED	BSS	01/11/13
Date	01/11/13			
<small>© Copyright Hanson Professional Services Inc. 2012 Hanson Professional Services Inc. 1525 S. Main Street Springfield, Illinois 62703-2886</small>				
CONSTRUCT A 2,065' X 35' PARTIAL PARALLEL TAXIWAY TO RUNWAY 13/31		PROPOSED ELECTRICAL ONE-LINE DIAGRAM FOR T-HANGAR SERVICE PANEL		
<p>63</p> <p>63 of 79 sheets</p>				

JAN 11, 2013 1:20 PM HARR01115
 p:\s\svr306\hanson\Documents\09\obs\09A0031\09A0031D\CAD\Airport\Sheet\E-602-LIN

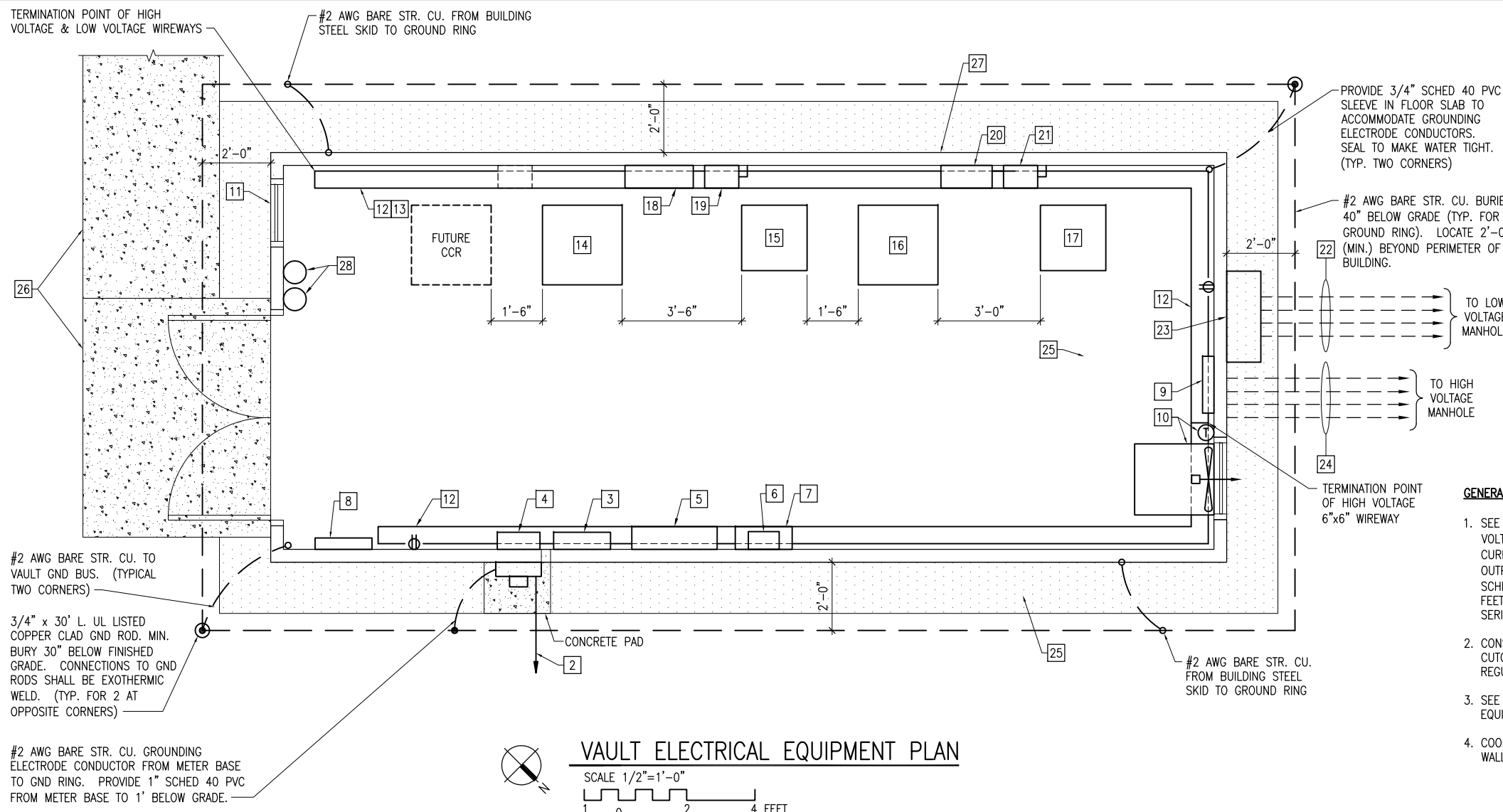

VAULT BUILDING NOTES

THE PROPOSED ELECTRICAL VAULT BUILDING SHALL CONSIST OF A PRE-FRABRICATED, PRE-ENGINEERED EQUIPMENT ENCLOSURE BUILDING WITH A CONCRETE FLOOR, STEEL SKID STRUCTURE AND FOUNDATION PIERS OR WITH CONCRETE SLAB FOUNDATION.

THE PROPOSED ELECTRICAL VAULT BUILDING SHALL HAVE A NOMINAL 12 FOOT WIDE EXTERIOR (INTERIOR WIDTH SHALL NOT BE LESS THAN 11 FEET, ADJUST EXTERIOR WIDTH AS APPLICABLE) BY NOMINAL 28 FEET IN LENGTH (INTERIOR LENGTH SHALL NOT BE LESS THAN 27 FEET, ADJUST EXTERIOR LENGTH AS APPLICABLE) BY NOMINAL 9 FEET HIGH INTERIOR (FLOOR TO CEILING).

- GENERAL NOTES**
- SEE "PROPOSED ELECTRICAL ONE-LINE FOR VAULT AND AIRFIELD" FOR LOW VOLTAGE INPUT POWER WIRING REQUIREMENTS TO CCR'S (CONSTANT CURRENT REGULATORS). SEE HIGH VOLTAGE WIRING SCHEMATICS FOR CCR OUTPUT WIRING REQUIREMENTS. SEE "AIRFIELD LIGHTING CONTROL WIRING SCHEMATIC" AND FOR CCR CONTROL WIRING REQUIREMENTS. PROVIDE 5 FEET MINIMUM CLEAR WORKING SPACE IN FRONT OF EACH CCR AND EACH SERIES PLUG CUTOUT.
 - CONSTANT CURRENT REGULATORS AND THEIR RESPECTIVE SERIES PLUG CUTOUTS SHALL BE CLEARLY LABELED TO IDENTIFY THE RESPECTIVE REGULATOR DESIGNATION, AND RUNWAY OR TAXIWAY SERVED.
 - SEE ELEVATION VIEWS FOR ADDITIONAL INFORMATION ON PROPOSED EQUIPMENT LAYOUTS.
 - COORDINATE CONDUIT & SLEEVE ENTRANCES THROUGH FLOOR SLAB AND WALLS.

VAULT ELECTRICAL EQUIPMENT PLAN
 SCALE 1/2"=1'-0"
 1 0 2 4 FEET

KEYED NOTES

- ELECTRIC UTILITY METER WITH SUPPORT HARDWARE PER SERVING ELECTRIC UTILITY COMPANY REQUIREMENTS. ADJUST LOCATION TO COORDINATE WITH VAULT LAYOUT AND CONDUIT TO SERVICE PANELBOARD.
- UTILITY SERVICE CONDUCTORS IN 3 1/2" SCHED. 80 PVC C. FROM UTILITY TRANSFORMER TO METER BASE. CONTRACTOR SHALL FURNISH AND INSTALL SERVICE CONDUCTORS AND CONDUIT FROM METER BASE TO SERVICE PANEL. SEE "PROPOSED ELECTRICAL ONE LINE DIAGRAM FOR VAULT AND AIRFIELD".
- VAULT SERVICE AND DISTRIBUTION PANEL. SEE SCHEDULE.
- AC SURGE PROTECTION DEVICE.
- LIGHTING CONTACTOR PANEL. SEE "LIGHTING CONTACTOR PANEL DETAIL".
- L-854 RADIO CONTROL UNIT. EXTEND RADIO ANTENNA CABLE IN 3/4" GRSC AND MOUNT ANTENNA ABOVE ROOF PEAK OF ADJACENT HANGAR FOR PROPER OPERATION. PROVIDE SCHED 40 PVC NIPPLE AT ENTRY TO VAULT FOR ISOLATION. BOND EXTERIOR METAL CONDUIT TO GND RING WITH PIPE CLAMP AND #2 AWG CU BONDING CONDUCTOR.
- RADIO RELAY INTERFACE PANEL WITH PHOTOCCELL BYPASS SWITCH FOR AIRFIELD LIGHTING SYSTEM. SEE "AIRFIELD LIGHTING CONTROL WIRING SCHEMATIC" FOR WIRING REQUIREMENTS. MOUNT PHOTOCCELL ABOVE ROOF LEVEL. FIELD VERIFY LOCATION FOR PROPER CONTROL AND OPERATION. PROVIDE SCHED 40 PVC NIPPLE AT ENTRY TO VAULT FOR ISOLATION. BOND EXTERIOR METAL CONDUIT TO GND RING WITH PIPE CLAMP AND #2 AWG CU BONDING CONDUCTOR.
- ELECTRIC WALL HEATER EH-1, 4000 WATT, 240 VAC, 1 PHASE, SUITABLE FOR SURFACE MOUNTING WITH INTEGRAL THERMOSTAT, Q-MARK MODEL CWH3404, OR EQUAL. HEATER SHALL BE MANUFACTURED IN THE UNITED STATES TO COMPLY WITH THE AIRPORT IMPROVEMENT PROGRAM BUY AMERICAN PREFERENCE REQUIREMENTS. LOCATE HEATER SUCH THAT IT IS NOT LESS THAN 8" FROM ADJACENT WALLS OR EQUIPMENT.
- ELECTRIC WALL HEATER EH-2 4000 WATT, 240 VAC, 1 PHASE, SUITABLE FOR SURFACE MOUNTING WITH INTEGRAL THERMOSTAT, Q-MARK MODEL CWH3404 OR APPROVED EQUAL. HEATER SHALL BE MANUFACTURED IN THE UNITED STATES TO COMPLY WITH THE AIRPORT IMPROVEMENT PROGRAM BUY AMERICAN PREFERENCE REQUIREMENTS. BOTTOM OF HEATER SHALL BE 8" (MIN.) ABOVE THE UPPER ELECTRICAL WIREWAY. COORDINATE WITH CCR INSTALLATION & FAN INSTALLATION. LOCATE HEATER ON WALL SUCH THAT IT IS NOT DIRECTLY BEHIND CCR. LOCATE HEATER SUCH THAT IT IS NOT LESS THAN 8" FROM ADJACENT WALLS OR EQUIPMENT.
- EXHAUST FAN EF-1, 3100 CFM (MINIMUM) AT .25" STATIC PRESSURE WITH 1/3 HP (MINIMUM), 120 VAC MOTOR, COOK MODEL 20S10D, OR APPROVED EQUAL. INCLUDE WALL HOUSING WITH GUARD, HEAVY DUTY BACK DRAFT DAMPER, ALUMINUM WEATHER-HOOD PAINTED TO MATCH BUILDING EXTERIOR, STAINLESS STEEL INSECT SCREEN, AND FRACTIONAL HP ELECTRICAL DISCONNECT. INSTALL FAN AS HIGH AS POSSIBLE. PROVIDE 120 VAC THERMOSTAT, AT 48" AFF. SEE EXHAUST FAN CONTROL SCHEMATIC FOR WIRING REQUIREMENTS. FAN SHALL BE MANUFACTURED IN THE UNITED STATES TO COMPLY WITH THE AIRPORT IMPROVEMENT PROGRAM BUY AMERICAN PREFERENCE REQUIREMENTS.
- INTAKE LOUVER L-1, 24" WIDE BY 48" HIGH INTAKE LOUVER WITH STAINLESS STEEL INSECT SCREEN, FLANGED FRAME, 120 VAC LOW LEAK MOTORIZED DAMPER WITH LIMIT SWITCH, KYNAR FINISH MATCHING BUILDING EXTERIOR, RUSKIN MODEL ELF375DX, OR APPROVED EQUAL. SEE EXHAUST FAN CONTROL SCHEMATIC FOR WIRING REQUIREMENTS. LOUVER / DAMPER SHALL BE MANUFACTURED IN THE UNITED STATES TO COMPLY WITH THE AIRPORT IMPROVEMENT PROGRAM BUY AMERICAN PREFERENCE REQUIREMENTS.
- 6" BY 6" LOW VOLTAGE WIREWAY. LABEL "LOW VOLTAGE" EVERY 6 FEET. INSTALL ABOVE HIGH VOLTAGE WIREWAY.
- 6" BY 6" HIGH VOLTAGE WIREWAY. LABEL "HIGH VOLTAGE" EVERY 6 FEET. INSTALL BELOW LOW VOLTAGE WIREWAY.
- NEW RUNWAY 13-31 CONSTANT CURRENT REGULATOR. SEE GENERAL NOTE 1.
- BACKUP/SPARE CCR FOR RUNWAY 13-31 RELOCATED FROM EXISTING VAULT. SEE GENERAL NOTE 1.
- NEW RUNWAY 18-36 CONSTANT CURRENT REGULATOR. SEE GENERAL NOTE 1.
- BACKUP/SPARE CCR FOR RUNWAY 18-36 RELOCATED FROM EXISTING VAULT. SEE GENERAL NOTE 1.
- TRANSFER PAIR SERIES PLUG CUTOUTS (TYPE S-1) WITH ENCLOSURE, FOR RUNWAY 13-31.
- 60 AMP, 240 VAC, 2P DOUBLE THROW FUSIBLE SAFETY SWITCH FOR RUNWAY 13-31 CCR'S.
- TRANSFER PAIR SERIES PLUG CUTOUTS (TYPE S-1) WITH ENCLOSURE, FOR RUNWAY 18-36.
- 60 AMP, 240 VAC, 2P DOUBLE THROW FUSIBLE SAFETY SWITCH FOR RUNWAY 18-36 CCR'S.
- 4-WAY 3" CONCRETE ENCASED DUCT FROM LOW VOLTAGE PULL BOX TO LOW VOLTAGE MANHOLE. PROVIDE 4-3" PVC COATED GRSC WITH PVC COATED GRSC ELBOWS AT TRANSITION FROM CONCRETE ENCASED DUCT TO PULL BOX. 3" GRSC AND ELBOWS WITH ASPHALT BASED PAINT IS ALSO ACCEPTABLE.
- NEMA 4X STAINLESS STEEL PULL BOX WITH HINGED COVER AND PAD LOCK FEATURE (MIN. 36"H X 36"W X 12" D). PROVIDE 4-3" GRSC NIPPLES THROUGH VAULT INTO LOW VOLTAGE WIREWAY.
- 4-WAY 3" CONCRETE ENCASED DUCT FROM HIGH VOLTAGE WIREWAY TO HIGH VOLTAGE MANHOLE. PROVIDE 4-3" PVC COATED GRSC WITH PVC COATED GRSC ELBOWS AT ENTRY TO VAULT. 3" GRSC AND ELBOWS WITH ASPHALT BASED PAINT IS ALSO ACCEPTABLE.
- VEGETATION BARRIER CONSISTING OF A 6" (MINIMUM) IDOT GRADATION CA-7 SURFACE OVER FILTER OR LANDSCAPING FABRIC. PROPOSED SURFACE TREATMENT WILL COVER ENTIRE AREA BENEATH VAULT STRUCTURE AS WELL AS 18" AROUND THE PERIMETER OF THE BUILDING EDGE. THE STONE AND FABRIC AS WELL AS ANY EQUIPMENT AND LABOR REQUIRED TO COMPLETE THIS TASK WILL BE CONSIDERED INCIDENTAL TO THE INSTALLATION OF THE PROPOSED ELECTRICAL VAULT AND NO ADDITIONAL COMPENSATION WILL BE ALLOWED.
- ENTRANCE PAD AND 4' WIDE SIDEWALK CONSTRUCTED OF 6" MIN. CONCRETE SLAB W/ 6X6-W5XW5 WELDED WIRE FABRIC ON A COMPACTED SUBGRADE. MINIMUM DIMENSIONS OF PAD WILL BE 7'x5'-6"Dx6"H, SLOPED AT A MIN. OF 0.5"/FT AWAY FROM THE VAULT ENTRANCE. THE CONCRETE PAD WILL BE PLACED AT LEAST 3" INTO THE EXISTING GRADE. STEP INTO VAULT BUILDING SHALL NOT EXCEED 7". PCC USED TO CONSTRUCT THE PAD WILL CONFORM TO ITEM 610. ALL MATERIALS, LABOR AND EQUIPMENT USED TO CONSTRUCT THE PAD AND 4' WIDE SIDEWALK INCLUDING ANY GRADING REQUIRED WILL BE CONSIDERED INCIDENTAL TO THE CONSTRUCTION OF THE PROPOSED ELECTRICAL VAULT AND NO ADDITIONAL COMPENSATION WILL BE ALLOWED.
- THE NUMBER, SIZE, DEPTH, REINFORCEMENT, AND LOCATION OF THE PROPOSED CONCRETE PIERS WILL BE COORDINATED WITH THE MANUFACTURER OF THE PROPOSED ELECTRICAL VAULT BUILDING. THE TOP OF THE PROPOSED PIERS WILL BE AT LEAST 4" ABOVE THE EXISTING GRADE.
- FURNISH AND INSTALL A UL RATED, 10 POUND CARBON DIOXIDE FIRE EXTINGUISHER SUITABLE FOR USE ON CLASS C FIRES AND A 10 POUND CLASS 4A:80B:C DRY CHEMICAL ABC FIRE EXTINGUISHER SUITABLE FOR USE ON CLASS A,B,C FIRES, IN THE VAULT SHELTER. PER NFPA 10 "PORTABLE FIRE EXTINGUISHERS" CLASS C ARE FOR FIRES THAT INVOLVE ENERGIZED ELECTRICAL EQUIPMENT. FIRE EXTINGUISHERS SHALL BE MADE IN THE UNITED STATES OF AMERICA TO COMPLY WITH BUY AMERICAN REQUIREMENT. FIRE EXTINGUISHER TYPE CO2 SHALL BE AMEREX MODEL 330, ANSUL SENTRY 10 MODEL CD10A-1 OR APPROVED EQUAL. FIRE EXTINGUISHER DRY CHEMICAL TYPE ABC SHALL BE AMEREX MODEL B456, OR APPROVED EQUAL. PROVIDE WALL MOUNTING BRACKET FOR EACH FIRE EXTINGUISHER. CONFIRM MODEL NUMBERS WITH THE RESPECTIVE FIRE EXTINGUISHER MANUFACTURER.

REVISION	DATE	DESCRIPTION

MARSHALL COUNTY AIRPORT
 LACON, ILLINOIS
 BLOCK GRANT: 3-17-0059-B14
 IL PROJ.: C75-4218

Hanson Project No.	09A0031	LAYOUT	KNL	12/09/12
Filename	E-101-VLT-EP.dwg	DRAWN	MLH	12/09/12
Scale	AS SHOWN	REVIEWED	BSS	01/11/13
Date	01/11/13			

CONSTRUCT A 2,065' X 35'
 PARTIAL PARALLEL TAXIWAY
 TO RUNWAY 13/31
 PROPOSED VAULT
 ELECTRICAL EQUIPMENT
 PLAN

64
 64 of 79 sheets

JAN 11, 2013 1:20 PM HARR01115
 p:\s\sw306\hanson\Documents\09A0031\09A0031D\CAD\Airport\Sheet\E-101-VLT-EP.dwg

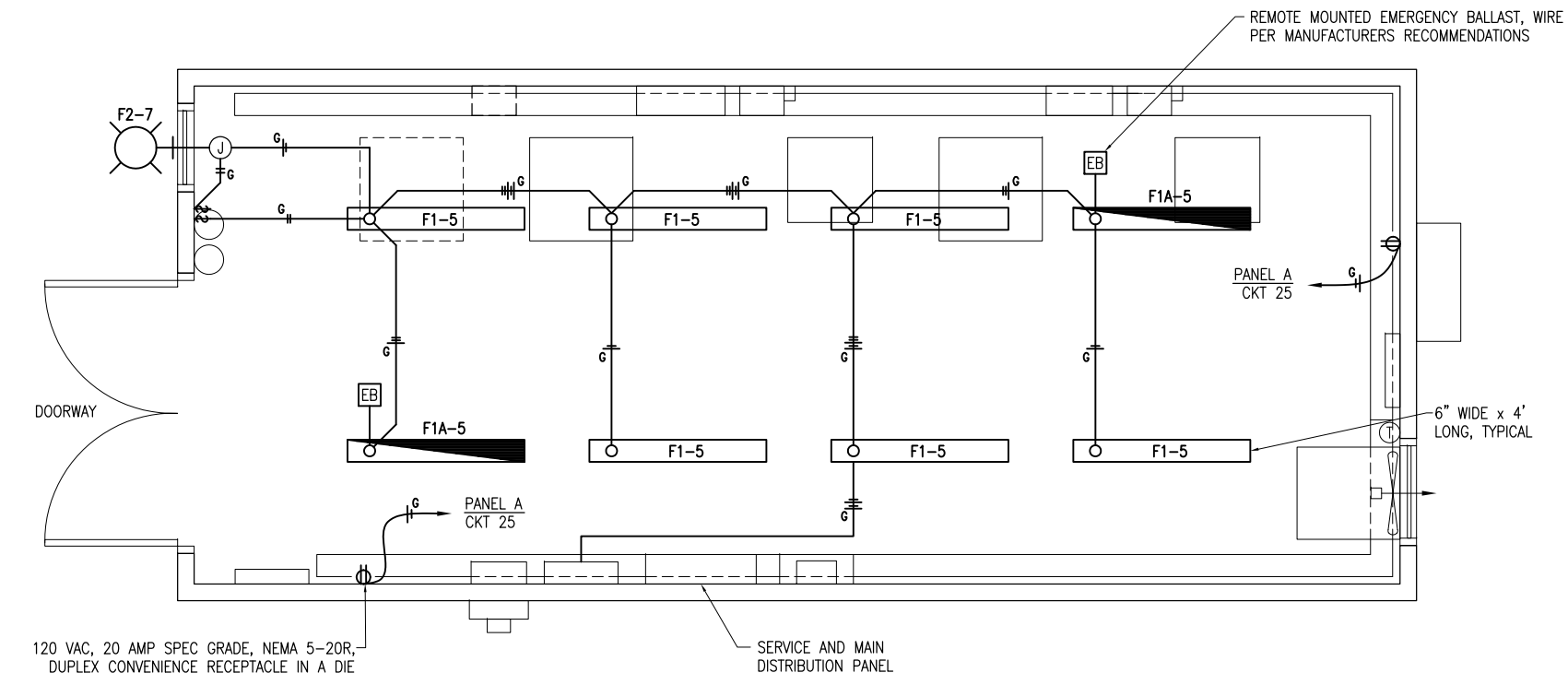

120 VAC, 20 AMP SPEC GRADE, NEMA 5-20R, DUPLEX CONVENIENCE RECEPTACLE IN A DIE CAST CONSTRUCTION HUBBELL/RACO/BELL, APPLETON, CROUSE-HINDS, OR APPROVED EQUAL WEATHERPROOF OUTLET BOX WITH STAINLESS STEEL COVER PLATE (TYP.)



VAULT LIGHTING AND RECEPTACLE PLAN

SCALE 1/2"=1'-0" [FULL-SIZE (22x34)]
 1 0 2 4 FEET

NOTES

- 15 AMP & 20 AMP BRANCH CIRCUITS FOR LIGHTING & RECEPTACLES SHALL USE #12 AWG THWN (MIN.). EMT MAY BE USED FOR LIGHTING AND RECEPTACLE BRANCH CIRCUITS.
- LIGHT FIXTURES SHALL BE MANUFACTURED IN THE UNITED STATES TO COMPLY WITH THE AIRPORT IMPROVEMENT PROGRAM BUY AMERICAN REQUIREMENTS. PROVIDE CERTIFICATION OF MANUFACTURE IN THE UNITED STATES WITH SHOP DRAWINGS SUBMITTAL.
- ADJUST RECEPTACLE LOCATIONS WHERE NECESSARY TO ACCOMMODATE EQUIPMENT LAYOUT.
- TEST EMERGENCY LIGHTING AND CONFIRM PROPER OPERATION.
- "USPOM" SUFFIX ON LITHONIA LIGHT FIXTURE CATALOG NUMBERS INDICATES UNITED STATES POINT OF MANUFACTURE.

LIGHTING FIXTURE SCHEDULE						
FIXT. TYPE	DESCRIPTION	MANUFACTURER & CATALOG NO.	LAMPS/WATTS	VOLTS	MOUNTING	REMARKS
F1	4 FT. WET LOCATION LISTED ENCLOSED AND GASKETED INDUSTRIAL FLUORESCENT LIGHT FIXTURE, IMPACT RESISTANT, UV RESISTANT REINFORCED POLYESTER FIBERGLASS HOUSING, HIGH IMPACT ACRYLIC DIFFUSER, RAPID START COLD WEATHER 0 DEG. F. ELECTRONIC BALLAST WITH LESS THAN OR EQUAL TO 10% THD.	LITHONIA: DMW-2-32-AR-120-CW-GE10RS-WLF-USPOM	2-32W T8 4100K 59 TOTAL INPUT WATTS	120	SURFACE TO HARD CEILING	PROVIDE WET LOCATION FITTINGS INSTALLED IN TOP OF FIXTURE.
F1A	SAME AS F1 EXCEPT PROVIDE AN EMERGENCY BALLAST CAPABLE OF OPERATING 2 LAMPS FOR 90 MINUTES AT 1100-1400 TOTAL LUMENS, BODINE #B50ST. NOTE BALLAST MIGHT REQUIRE TO BE REMOTE MOUNTED NEAR FIXTURE AS INDICATED ON THE PLANS.	LITHONIA: DMW-2-32-AR-120-CW-GE10RS-WLF-USPOM	2-32W T8 4100K 59 TOTAL INPUT WATTS	120	SURFACE TO HARD CEILING	PROVIDE WET LOCATION FITTINGS INSTALLED IN TOP OF FIXTURE.
F2	COMPACT FLUORESCENT WALL-PAK, ONE PIECE INJECTION MOLDED UV STABILIZED POLYCARBONATE HOUSING, HIGH PERFORMANCE SPECULAR ANODIZED SEGMENTED REFLECTOR, ONE PIECE HIGH TEMPERATURE SILICONE GASKET, MEDIUM BRONZE FINISH, HIGH POWERFACTOR ELECTRONIC BALLAST WITH LESS THAN OR EQUAL TO 10% THD, UL LISTED FOR WET LOCATIONS, FUSED.	LITHONIA: TWA-42TRT-120-SF-CR-DMB-LPI-USPOM	1-42W TRT 4100K 47 TOTAL INPUT WATTS	120	SURFACE TO WALL ABOVE AND TO THE LEFT OF EXTERIOR DOOR APPROXIMATELY 4 INCHES ABOVE TOP OF DOOR FRAME. ADJUST LOCATION TO ACCOMMODATE DOORWAY OVERHANG.	CONNECT TO WALL SWITCH LOCATED ON THE INSIDE OF THE BUILDING.

REVISION	DATE

MARSHALL COUNTY AIRPORT
LACON, ILLINOIS

IL PROJ.: C75-4218 BLOCK GRANT: 3-17-0059-B14

Hanson Project No.	09A0031	LAYOUT	12/09/12
Filename	E-102-VLT-LP.dwg	DRAWN	MLH
Scale	AS SHOWN	REVIEWED	BSS
Date	01/11/13		01/11/13



CONSTRUCT A 2,065' X 35' PARTIAL PARALLEL TAXIWAY TO RUNWAY 13/31
 PROPOSED VAULT LIGHTING AND RECEPTACLE PLAN

JAN 11, 2013 1:20 PM HARR01115
 pw:\sps-svr306\hanson.dom\hanson Projects\Documents\09\jobs\09A0031\09A0031D\CAD\Airport\Sheet\E-102-VLT-LP

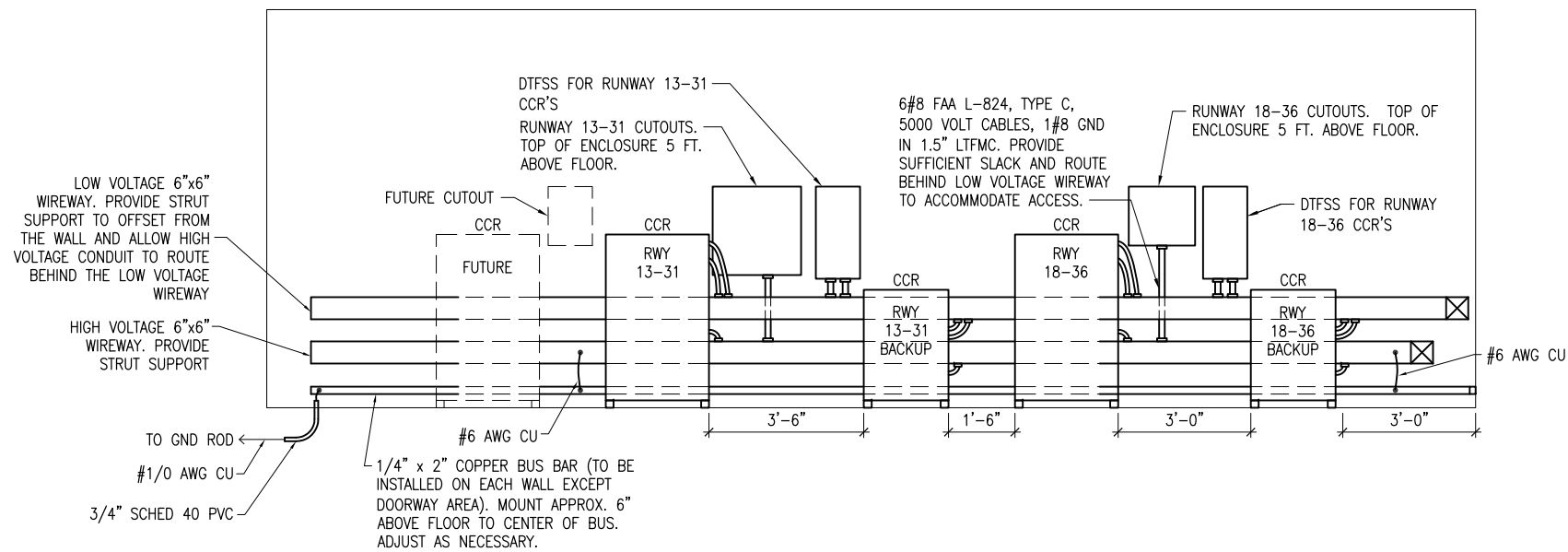

VAULT SOUTH WALL ELEVATION

SCALE 1/2"=1'-0"

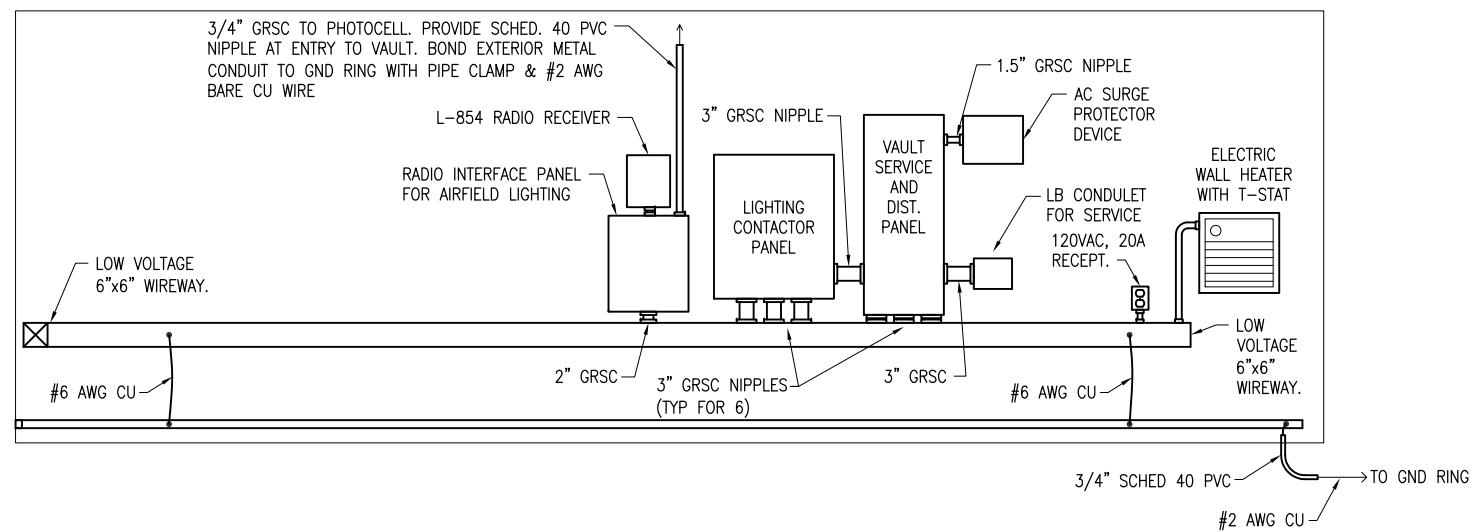

VAULT NORTH WALL ELEVATION

SCALE 1/2"=1'-0"

REVISION	DATE

MARSHALL COUNTY AIRPORT
LACON, ILLINOIS

IL PROJ.: C75-4218 BLOCK GRANT: 3-17-0059-B14

Revision	Date	By	Check

HANSON
Professional Services Inc.
1425 S. Main St.
Springfield, Illinois 62703-2886

CONSTRUCT A 2,065' X 35'
PARTIAL PARALLEL TAXIWAY
TO RUNWAY 13/31

PROPOSED AIRPORT VAULT
WALL ELEVATIONS (SHEET 1)

JAN 11, 2013 1:21 PM HARR01115
pw:\sps-svr306\hanson\dom\hanson_projects\Documents\09\jobs\09A0031\09A0031D\CAD\Airport\Sheet\E-201-VLT

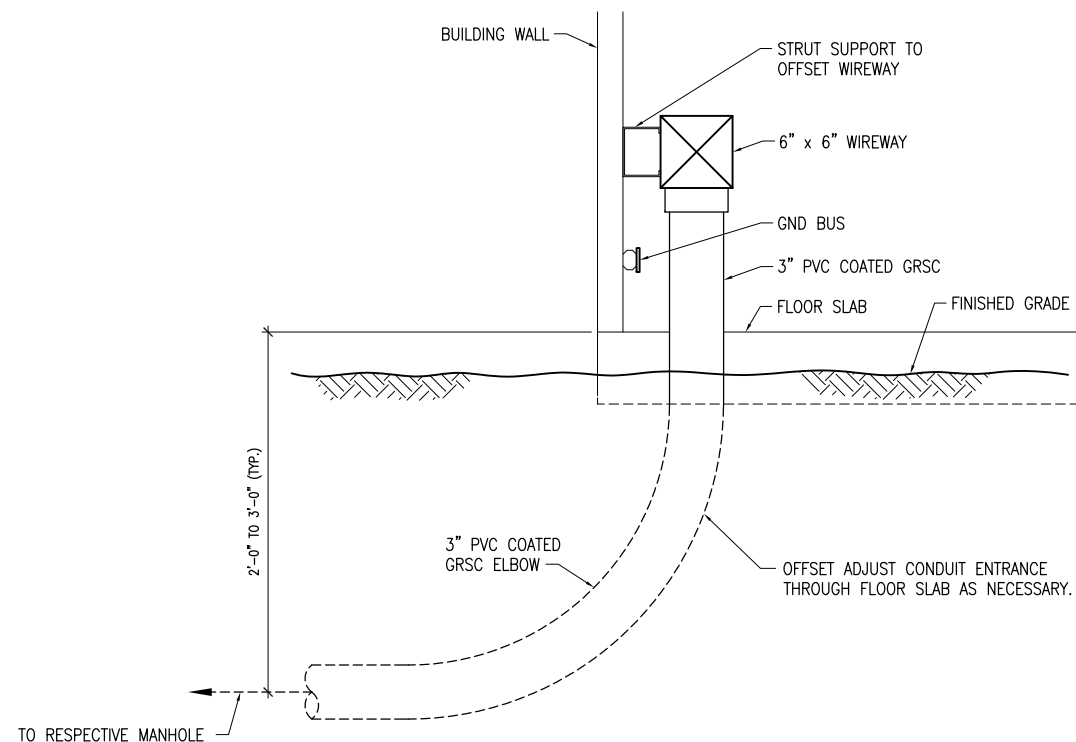

CONDUIT ENTRANCE DETAIL
 SCALE 1 1/2"=1'-0"
 0.5 0 1 2 FEET

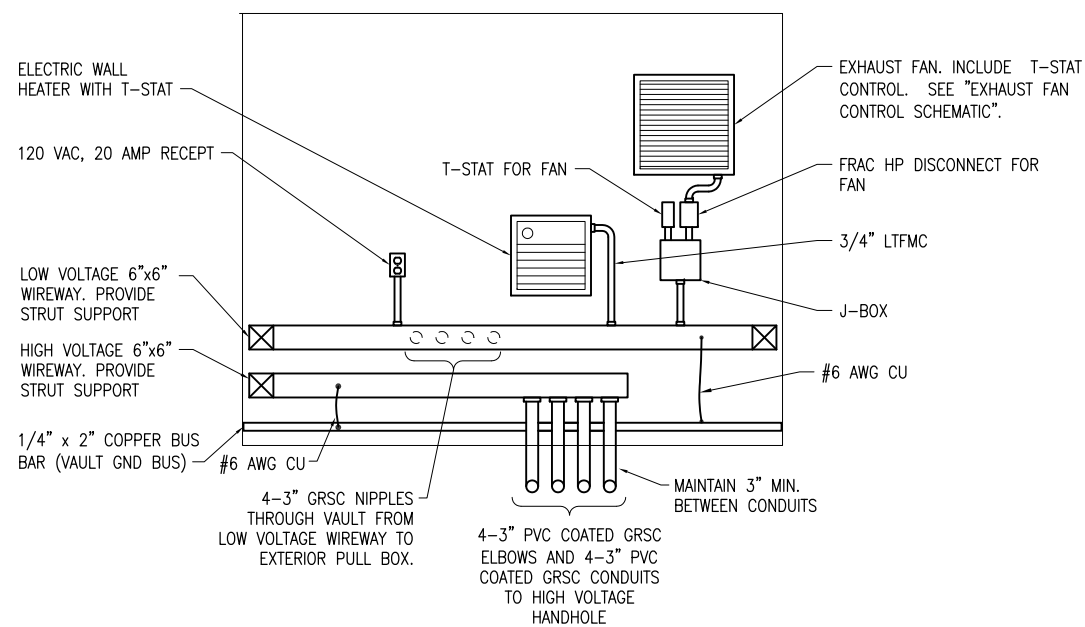

VAULT WEST WALL ELEVATION

SCALE 1/2"=1'-0"
 1 0 2 4 FEET

JAN 11, 2013 1:21 PM HARR01115
 pw:\sps-svr306\hanson\dom\hanson_projects\Documents\09\jobs\09A0031\09A0031D\CAD\Airport\Sheet\E-201-VLT

REVISION	DATE

MARSHALL COUNTY AIRPORT
 LACON, ILLINOIS

IL PROJ.: C75-4218 BLOCK GRANT: 3-17-0059-B14

Hanson Project No.	09A0031
Filename	E-201-VLT.dwg
Scale	AS SHOWN
Date	01/11/13
LAYOUT	KNL 12/09/12
DRAWN	MLH 12/09/12
REVIEWED	BSS 01/11/13

© Copyright Hanson Professional Services Inc. 2012
 Hanson Professional Services Inc.
 1525 S. 36th Street
 Springfield, Illinois 62703-2886

CONSTRUCT A 2,065' X 35'
 PARTIAL PARALLEL TAXIWAY
 TO RUNWAY 13/31
 PROPOSED AIRPORT VAULT
 WALL ELEVATIONS (SHEET 2)

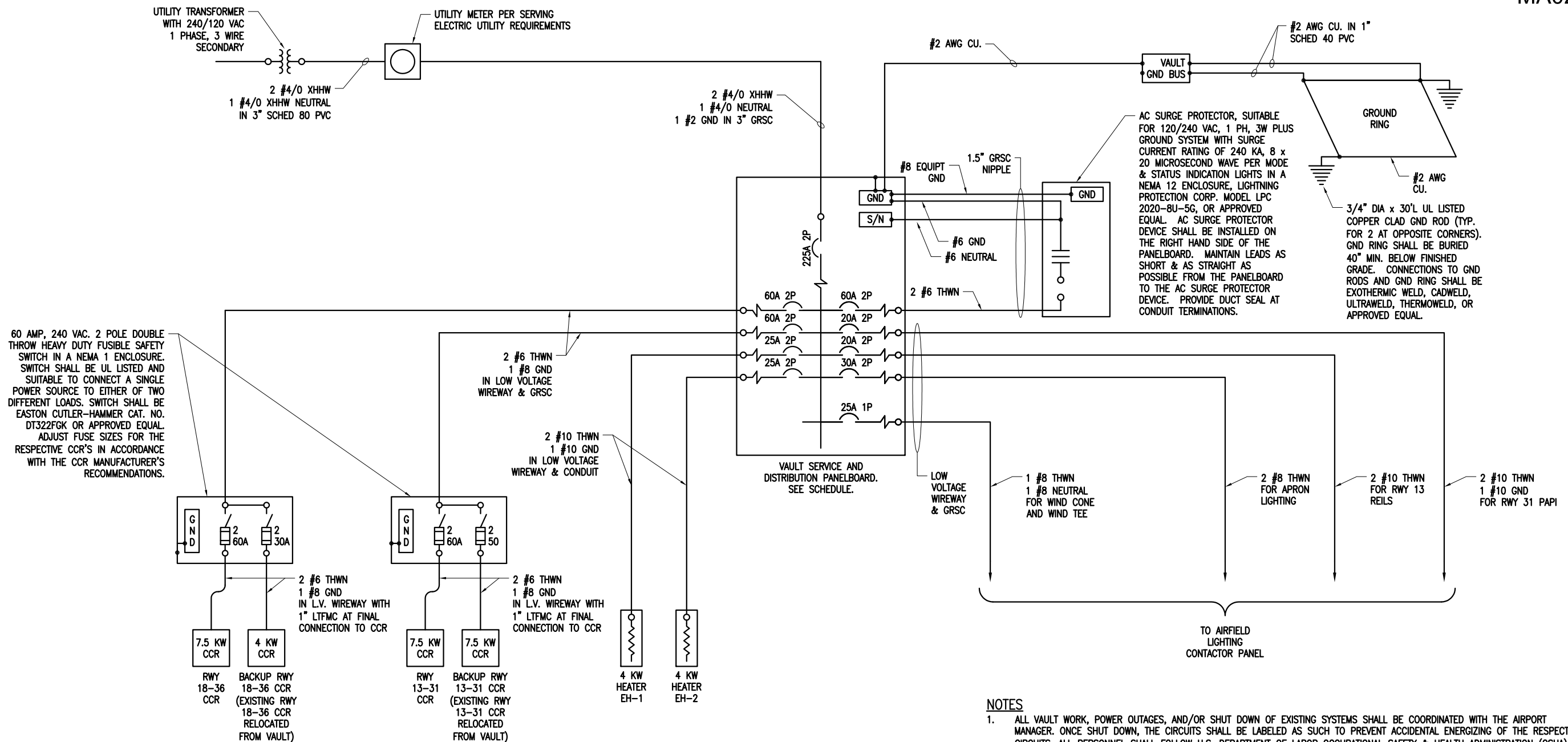

PROPOSED ELECTRICAL ONE-LINE DIAGRAM FOR VAULT AND AIRFIELD

- NOTES**
1. ALL VAULT WORK, POWER OUTAGES, AND/OR SHUT DOWN OF EXISTING SYSTEMS SHALL BE COORDINATED WITH THE AIRPORT MANAGER. ONCE SHUT DOWN, THE CIRCUITS SHALL BE LABELED AS SUCH TO PREVENT ACCIDENTAL ENERGIZING OF THE RESPECTIVE CIRCUITS. ALL PERSONNEL SHALL FOLLOW U.S. DEPARTMENT OF LABOR OCCUPATIONAL SAFETY & HEALTH ADMINISTRATION (OSHA) 29 CFR PART 1910 OCCUPATIONAL SAFETY & HEALTH STANDARDS FOR ELECTRICAL SAFETY AND LOCKOUT/TAGOUT PROCEDURES INCLUDING, BUT NOT LIMITED TO, 29 CFR SECTION 1910.147 THE CONTROL OF HAZARDOUS ENERGY (LOCKOUT/TAGOUT).
 2. ALL ELECTRICAL EQUIPMENT SHALL BE INSTALLED IN CONFORMANCE WITH NFPA 70 - NATIONAL ELECTRICAL CODE (NEC) MOST CURRENT ISSUE IN FORCE, THE RESPECTIVE EQUIPMENT MANUFACTURER'S DIRECTIONS AND ALL OTHER APPLICABLE LOCAL CODES, LAWS, ORDINANCES AND REQUIREMENTS IN FORCE. ANY INSTALLATIONS WHICH VOID THE U.L. LISTING, ETL LISTING, (OR OTHER THIRD PARTY LISTING) AND/OR THE MANUFACTURER'S WARRANTY OF A DEVICE WILL NOT BE PERMITTED.
 3. ALL CONDUCTORS/WIRING SHALL BE COPPER.
 4. CONTRACTOR SHALL CONFIRM POWER REQUIREMENTS WITH THE ACTUAL NAMEPLATE ON EACH CONSTANT CURRENT REGULATOR (OR OTHER RESPECTIVE EQUIPMENT) AND ADJUST CIRCUIT BREAKER, WIRE SIZES & CONDUIT SIZES TO CONFORM WITH NEC & MANUFACTURER'S RECOMMENDATIONS WHERE APPLICABLE. WIRE SIZES SHOWN ON THE PLANS ARE MINIMUM.
 5. HIGH VOLTAGE & LOW VOLTAGE CIRCUITS SHALL NOT BE INSTALLED IN THE SAME WIREWAY, CONDUIT, HANDHOLE, MANHOLES, JUNCTION BOX, OR RACEWAY.
 6. LTFMC DENOTES LIQUID TIGHT FLEXIBLE METAL CONDUIT UL LISTED, SUNLIGHT RESISTANT, & SUITABLE FOR GROUNDING. LIQUID TIGHT FLEXIBLE METAL CONDUIT AND ASSOCIATED FITTINGS SHALL BE U.L. LISTED TO MEET THE REQUIREMENTS OF NEC 350.6. LIQUID TIGHT FLEXIBLE METAL CONDUIT THAT IS USED FOR FLEXIBILITY (INCLUDING CONNECTIONS TO CCR'S & TRANSFORMERS) SHALL REQUIRE AN EXTERNAL BONDING JUMPER OR INTERNAL EQUIPMENT GROUNDING CONDUCTOR PER NEC 350.60. EXTERNAL BONDING JUMPERS USED WITH CCR INSTALLATIONS SHALL BE #6 AWG COPPER (MINIMUM). DO NOT INSTALL LTFMC THAT IS NOT UL LISTED. CONFIRM LTFMC BEARS THE UL LABEL PRIOR TO INSTALLATION.
 7. CONTRACTOR SHALL COORDINATE NEW ELECTRICAL SERVICE WITH THE SERVING ELECTRIC UTILITY AND THE AIRPORT MANAGER. CONTRACTOR SHALL CONFIRM REQUIREMENTS WITH SERVING ELECTRIC UTILITY COMPANY. THE SERVING ELECTRIC UTILITY IS AMEREN.
 8. ALL WORK SHOWN ON THIS SHEET SHALL BE PAID FOR UNDER ITEM AR109200 INSTALL ELECTRICAL EQUIPMENT PER LUMP SUM.

REVISION	
DATE	

MARSHALL COUNTY AIRPORT
LACON, ILLINOIS

IL PROJ.: C75-4218
BLOCK GRANT: 3-17-0059-B14

Hanson Project No.	09A0031
Filename	E-603-LIN.dwg
Scale	NOT TO SCALE
Date	01/11/13
LAYOUT	KNL 11/10/12
DRAWN	MLH 11/23/12
REVIEWED	BSS 01/11/13



CONSTRUCT A 2,065' X 35'
PARTIAL PARALLEL TAXIWAY
TO RUNWAY 13/31

PROPOSED ELECTRICAL
ONE-LINE DIAGRAM FOR VAULT
AND AIRFIELD

JAN 11, 2013 1:21 PM HARR01115
pw:\sps-svr306\hanson\Documents\09\jobs\09A0031\09A0031\0 CAD\Airport\Sheet\E-603-LIN

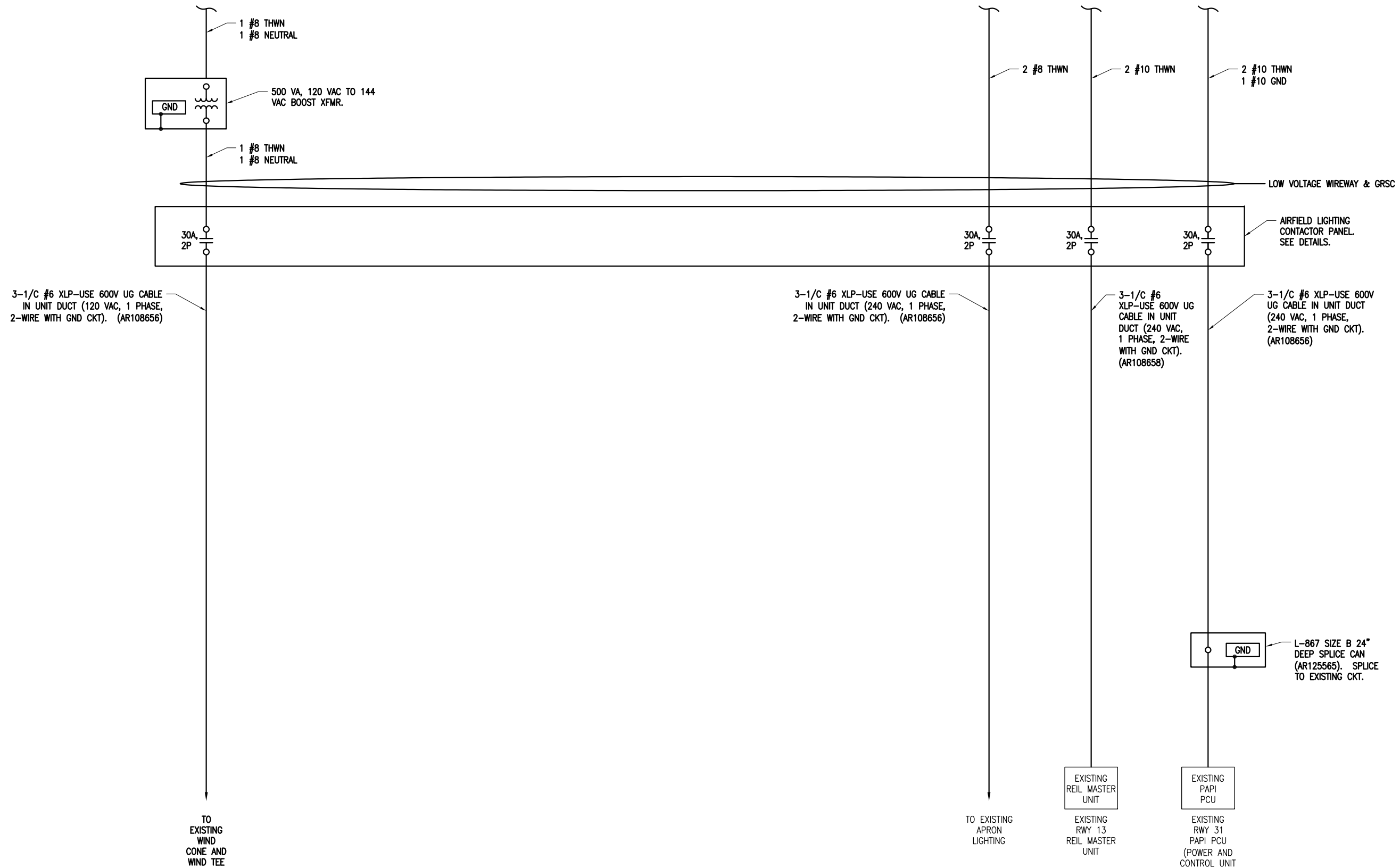

PROPOSED ELECTRICAL ONE-LINE DIAGRAM FOR VAULT AND AIRFIELD (CONTINUED)

REVISION	DATE

MARSHALL COUNTY AIRPORT
LACON, ILLINOIS

IL. PROJ.: C75-4218 BLOCK GRANT: 3-17-0059-B14

Hanson Project No.	09A0031
Filename	E-604-LIN.dwg
Scale	NOT TO SCALE
Date	01/11/13
LAYOUT	KNL 11/10/12
DRAWN	MLH 11/24/12
REVIEWED	BSS 01/11/13

HANSON
Professional Services Inc.
1525 South Main Street
Springfield, Illinois 62703-2886

CONSTRUCT A 2,065' X 35' PARTIAL PARALLEL TAXIWAY TO RUNWAY 13/31

PROPOSED ELECTRICAL ONE-LINE DIAGRAM FOR VAULT AND AIRFIELD CONTINUED

JAN 14, 2013 6:33 PM HARR01115
pw:\sps-svc306\hanson.dom\hanson Projects\Documents\09\jobs\09A0031\09A0031\CAD\Airport\Sheet\E-604-LIN

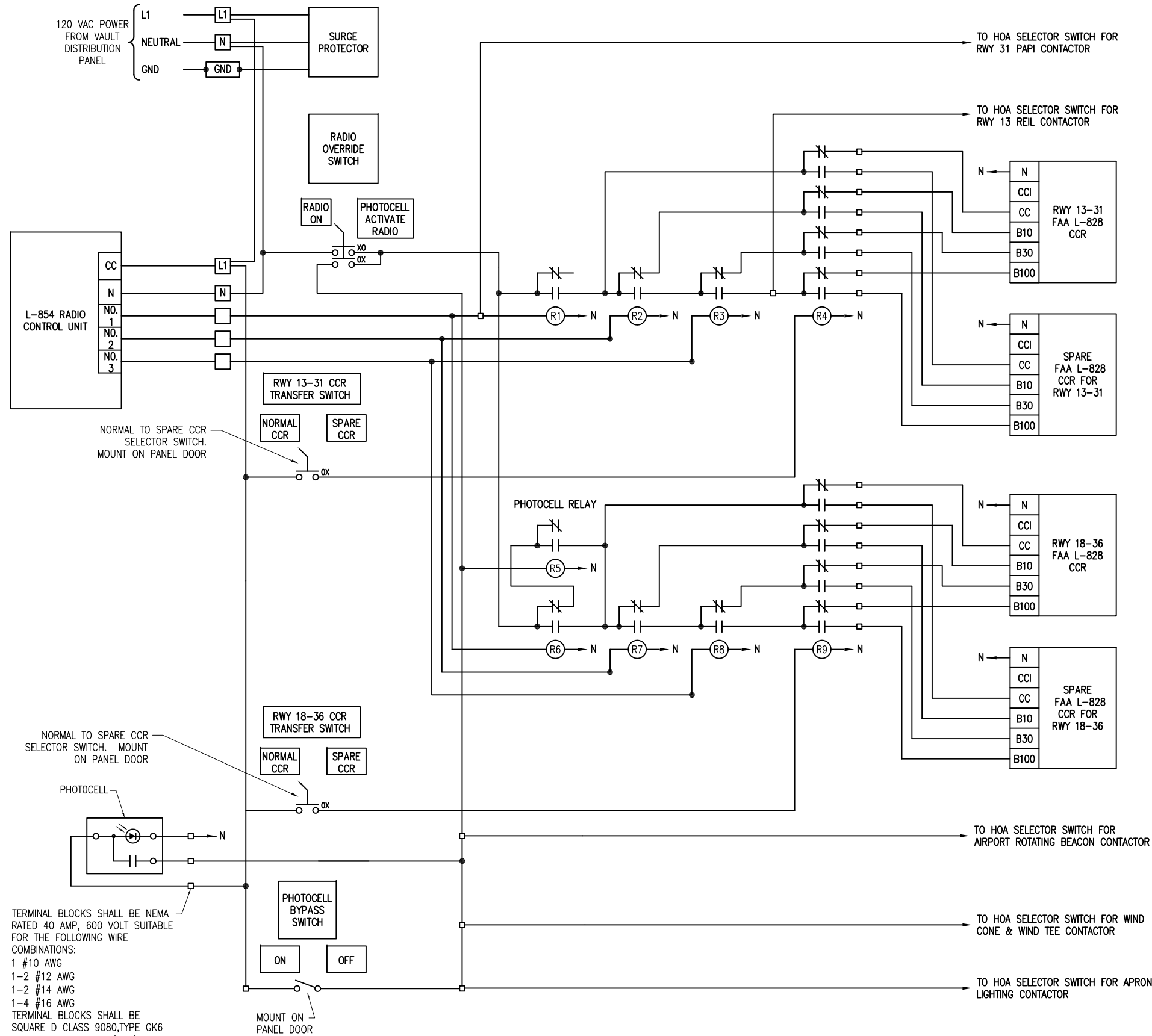

AIRFIELD LIGHTING CONTROL WIRING SCHEMATIC

NOTES:

- RELAY INTERFACE CONTROL PANEL SHALL BE MANUFACTURED BY AN FAA APPROVED L-821 PANEL BUILDER OR A UL 508 INDUSTRIAL CONTROL PANEL BUILDER, AND SHALL BE MANUFACTURED IN THE UNITED STATES TO COMPLY WITH THE AIRPORT IMPROVEMENT PROGRAM BUY AMERICAN REQUIREMENT AND THE "BUY AMERICAN ACT". RELAY INTERFACE CONTROL PANEL SHALL BE A SEPARATE PANEL. DO NOT COMBINE WITH LIGHTING CONTACTOR PANEL.
- PANEL SHALL BE IN A NEMA 12 ENCLOSURE WITH HINGED COVER. DRILL HOLE IN BOTTOM OF ENCLOSURE TO ALLOW CONDENSATION TO ESCAPE.
- EXTERNAL CONTROL CABLE SHALL BE NO. 12 AWG COPPER, 600 VOLT CABLE. ALL PANEL INTERIOR CONTROL CABLE SHALL BE MINIMUM 16 AWG, COPPER, 600 VOLT CABLE.
- IN THE AUTOMATIC MODE OF OPERATION THE RUNWAY 13-31 CONTROLLED BY THE PHOTOCELL & THE L-854 RADIO CONTROL UNIT IN THE FOLLOWING MANNER:
PHOTOCELL -ACTIVATE RADIO CONTROL
3 CLICKS -10% BRIGHTNESS
5 CLICKS -30% BRIGHTNESS
7 CLICKS -100% BRIGHTNESS
- THE RUNWAY 31 PAPI CIRCUIT WILL BE CONTROLLED IN THE AUTOMATIC MODE BY THE L-854 RADIO CONTROL UNIT IN THE FOLLOWING MANNER. CONFIRM CONTROL WITH AIRPORT MANAGER.
3 CLICKS - ON
5 CLICKS - REMAIN ON
7 CLICKS - REMAIN ON
- THE RUNWAY 13 REIL CIRCUIT WILL BE CONTROLLED IN THE AUTOMATIC MODE BY THE PHOTOCELL & THE L-854 RADIO CONTROL UNIT IN THE FOLLOWING MANNER.
PHOTOCELL ACTIVATION ENABLES RADIO CONTROL
3 CLICKS - OFF
5 CLICKS - OFF
7 CLICKS - ON
- IN THE AUTOMATIC MODE OF OPERATION THE RUNWAY 18-36 CONSTANT CURRENT REGULATORS (PRIMARY UNIT & SPARE UNIT) SHALL BE CONTROLLED BY THE PHOTOCELL & THE L-854 RADIO CONTROL UNIT IN THE FOLLOWING MANNER:
PHOTOCELL - 10% BRIGHTNESS & ACTIVATE RADIO CONTROL
5 CLICKS - 30% BRIGHTNESS
7 CLICKS - 100% BRIGHTNESS
- THE RADIO OVERRIDE SWITCH WILL ACTIVATE L-854 RADIO CONTROL 24 HOURS PER DAY IN THE "RADIO ON" POSITION. THE PHOTOCELL WILL ACTIVATE RADIO CONTROL IN THE "PHOTOCELL ACTIVATE RADIO" POSITION.
- IN THE AUTOMATIC MODE OF OPERATION THE AIRPORT ROTATING BEACON SHALL BE ACTIVATED BY THE PHOTOCELL OR PHOTOCELL BYPASS SWITCH.
- EQUIPMENT GROUND WIRES SHALL BE INCLUDED WITH EACH BRANCH CIRCUIT & EACH CONTROL CIRCUIT.
- INCLUDE PHOTOCELL BYPASS SWITCH.
- SURGE PROTECTOR SHALL BE UL LISTED PER UL 1449, SUITABLE FOR 120 VAC, 1 PH, 2 WIRE PLUS GROUND SYSTEM WITH SURGE CURRENT RATING OF 40 KA (MIN.), 8x20 MICROSECOND WAVE, AND STATUS INDICATION LIGHTS IN A WEATHERPROOF HOUSING, JOSLYN MODEL 1260-21, OR APPROVED EQUAL. MAINTAIN LEADS AS SHORT & AS STRAIGHT AS POSSIBLE. INCLUDE MOUNTING BRACKET.
- INCLUDE EQUIPMENT GROUND BAR, ILSCO D167-12 OR EQUAL
- CONTROL RELAYS SHALL HAVE 10 AMP CONTACT RATINGS AT 240 VAC WITH 120 VAC COILS. PROVIDE 3 SPARE RELAYS FOR EACH TYPE USED IN THE RELAY INTERFACE PANEL.
- COLOR CODING FOR THE CONTROL WIRING TO EACH CONSTANT CURRENT REGULATOR SHALL BE CONSISTENT FOR ALL REGULATORS. COLOR CODING SHALL BE AS FOLLOWS:
CC -RED
10% -ORANGE
30% -YELLOW
100% -BLUE
NEUTRAL -WHITE
EQUIPT. GND -GREEN
ALSO TAG THE CONTROL WIRES WITH THE RESPECTIVE DESIGNATION (CC, 10%, 30%, 100%)
- "N" DESIGNATES NEUTRAL CONNECTION OR NEUTRAL CONDUCTOR.

TERMINAL BLOCKS SHALL BE NEMA RATED 40 AMP, 600 VOLT SUITABLE FOR THE FOLLOWING WIRE COMBINATIONS:
1 #10 AWG
1-2 #12 AWG
1-2 #14 AWG
1-4 #16 AWG
TERMINAL BLOCKS SHALL BE SQUARE D CLASS 9080, TYPE GK6 OR APPROVED EQUAL (TYP.) IEC RATED TERMINALS ARE NOT ACCEPTABLE.

REVISION				
DATE				
MARSHALL COUNTY AIRPORT LACON, ILLINOIS				
BLOCK GRANT: 3-17-0059-B14 IL PROJ.: C75-4218				
Hanson Project No.	09A0031	LAYOUT	KNL	11/11/12
Filename	E-607-SCM.dwg	DRAWN	TRR	11/14/12
Scale	NOT TO SCALE	REVIEWED	BSS	01/11/13
Date	01/11/13			
<small>© Copyright Hanson Professional Services Inc. 2012 Hanson Professional Services Inc. 1525 S. 36th St. Ste. 200 Springfield, Illinois 62703-2886</small>				
CONSTRUCT A 2,065' X 35' PARTIAL PARALLEL TAXIWAY TO RUNWAY 13/31		AIRFIELD LIGHTING CONTROL WIRING SCHEMATIC		
71				
71 of 79 sheets				

JAN 11, 2013 1:21 PM HARR01115
 pw:\sps-svr306\hanson\Documents\09jobs\09A0031\09A0031D\CAD\Airport\Sheet\E-607-SCM

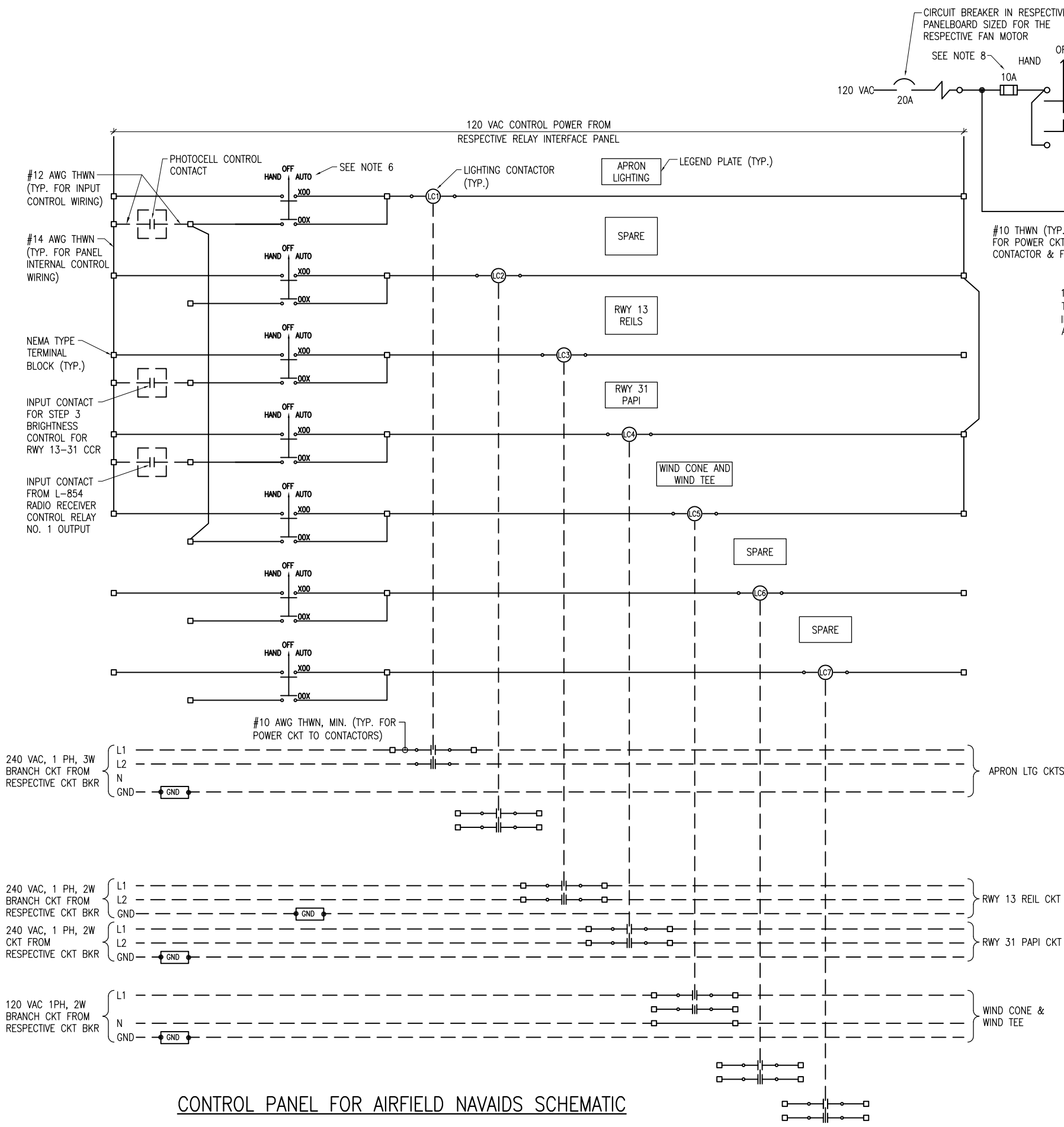

CONTROL PANEL FOR AIRFIELD NAVAIDS SCHEMATIC

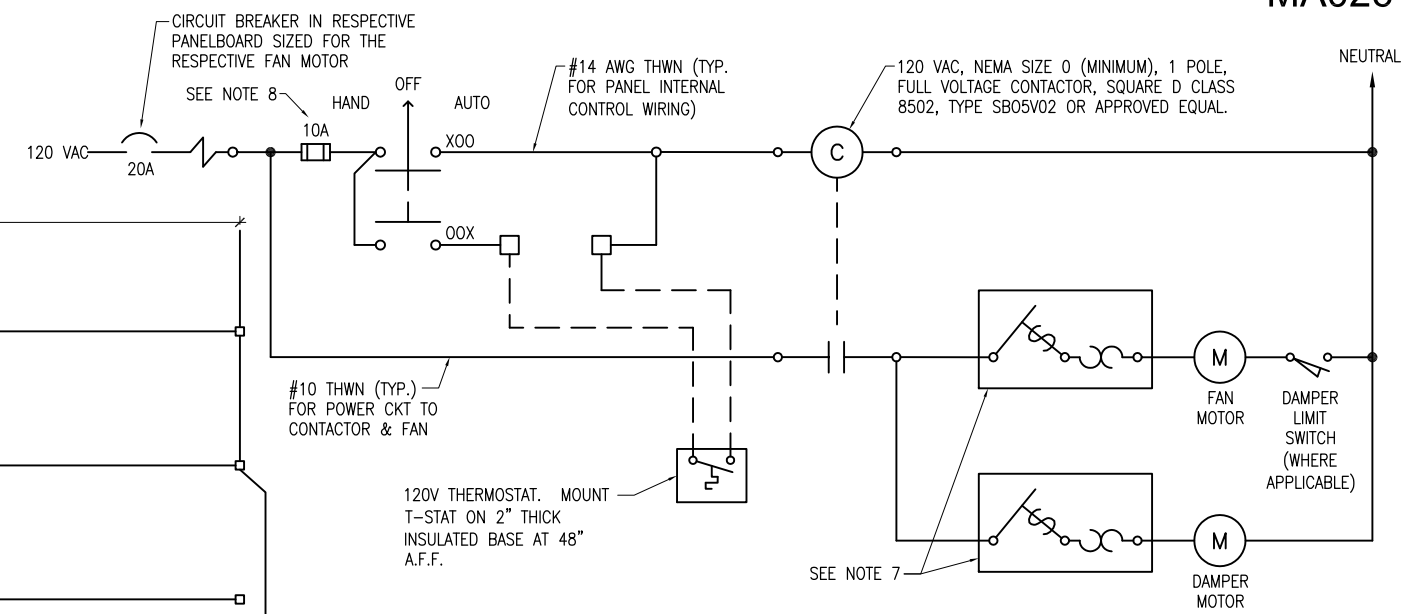

EXHAUST FAN CONTROL SCHEMATIC

NOTES

- 15 AMP & 20 AMP INPUT POWER/BRANCH CIRCUITS SHALL BE #10 AWG COPPER THWN FROM THE RESPECTIVE POWER SOURCE TO THE LIGHTING CONTACTOR/RELAY PANEL. 25 AMP AND 30 AMP INPUT POWER/BRANCH CIRCUITS SHALL BE #8 AWG COPPER THWN (MIN.) FROM THE RESPECTIVE POWER SOURCE TO THE LIGHTING CONTACTOR/RELAY PANEL.
- INPUT CONTROL CIRCUIT WIRING SHALL BE #12 AWG COPPER THWN.
- FOR 120 VAC BRANCH CIRCUITS THE NEUTRAL CONDUCTOR SHALL NOT BE SWITCHED THROUGH THE RELAY CONTACTS. USE TERMINAL BLOCKS TO TRANSITION FROM VAULT BRANCH CIRCUIT WIRING TO FIELD WIRING.
- THE AIRPORT ROTATING BEACON CIRCUIT SHALL HAVE PHASE "A" SWITCHED THROUGH THE LIGHTING CONTACTOR. PHASE "B" SHALL BE UNSWITCHED FROM THE POWER SOURCE TO THE LOAD CENTER AT THE AIRPORT ROTATING BEACON.
- PROVIDE #10 AWG COPPER BONDING JUMPER FROM PANEL ENCLOSURE FRAME TO ENCLOSURE DOOR.
- PROVIDE 3-POSITION MAINTAINED CONTACT "HAND-OFF-AUTO" SELECTOR SWITCH FOR EACH LIGHTING CONTACTOR & MOUNT ON LIGHTING CONTACTOR PANEL ENCLOSURE DOOR. SELECTOR SWITCH SHALL BE SQUARE D CLASS 9001, TYPE KS43FBH13, OR APPROVED EQUAL. INCLUDE LEGEND PLATE TO IDENTIFY THE DEVICE CONTROLLED (EX: "WIND CONE" OR "AIRPORT ROTATING BEACON").
- PROVIDE FRACTIONAL HORSEPOWER MOTOR MANUAL STARTER, SQUARE D MANUAL STARTER WITH HANDLE/GUARD/LOCK OFF, IN NEMA 4 ENCLOSURE CLASS 2510, TYPE FGS OR APPROVED EQUAL FOR FAN MOTOR & DAMPER MOTOR. INCLUDE MELTING ALLOY TYPE THERMAL OVERLOADS SIZED AS REQUIRED TO PROTECT THE RESPECTIVE MOTOR. 120 VAC MOTORS SHALL HAVE SINGLE POLE STARTERS.
- FUSING FOR CONTROL WIRING SHALL BE 10 AMP, 600 VAC, BUSSMANN CATALOG FNQ-R-10, OR APPROVED EQUAL, WITH FUSE BLOCKS, WITH BOX LUG TERMINALS, SIZED AS REQUIRED FOR THE RESPECTIVE APPLICATION. INCLUDE HARDWARE FOR MOUNTING. PROVIDE ONE BOX (5 MINIMUM QUANTITY) OF EACH TYPE AND SIZE OF FUSE, UPON COMPLETION OF THE JOB FOR USE AS SPARES.

REVISION	DATE

MARSHALL COUNTY AIRPORT
LACON, ILLINOIS

IL PROJ.: C75-4218 BLOCK GRANT: 3-17-0059-B14

FILENAME	SCALE	DATE	LAYOUT	KNL	11/10/12
E-605-SCM.dwg	NOT TO SCALE	01/11/13			
			DRAWN	TRR	11/14/12
			REVIEWED	BSS	01/11/13

HANSON

Copyright Hanson Professional Services Inc. 2012
Hanson Professional Services Inc.
1525 S. 38th St. Ste. 100
Springfield, Illinois 62703-2886

CONSTRUCT A 2,065' X 35'
PARTIAL PARALLEL TAXIWAY
TO RUNWAY 13/31

CONTROL PANEL FOR
AIRFIELD NAVAIDS
SCHEMATIC

JAN 11, 2013 1:21 PM HARR01115
pw:\sps-svc306\hanson\Documents\09\jobs\09A0031\09A0031D\CAD\Airport\Sheet\E-605-SCM

JAN 11, 2013 1:21 PM HARR01115
 pw:\sps-sv306\hanson\Documents\09jobs\09A0031\09A0031D\CAD\Airport\Sheet\E-606-ELE

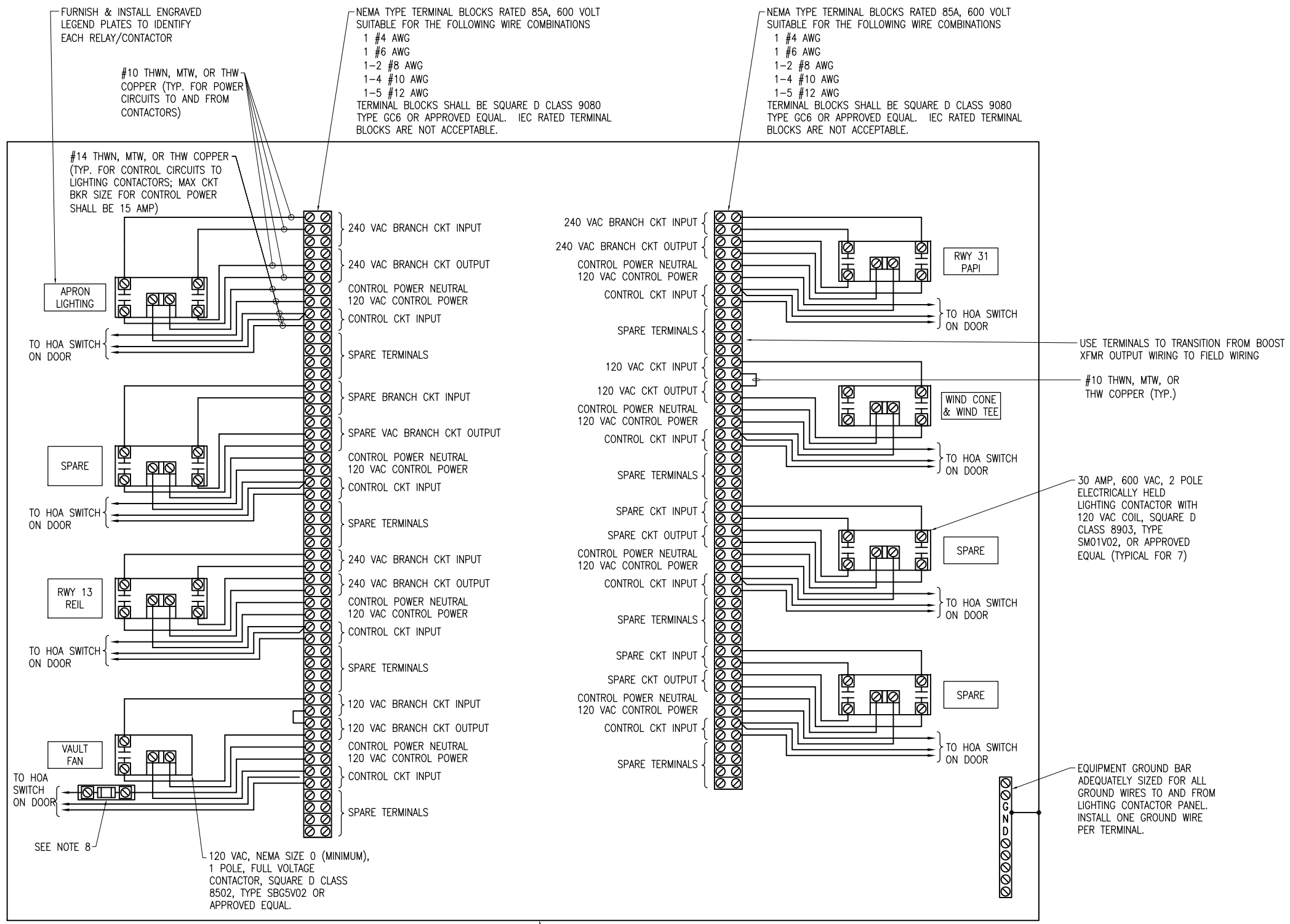

- NOTES**
- 15 AMP & 20 AMP INPUT POWER/BRANCH CIRCUITS SHALL BE #10 AWG COPPER THWN FROM THE RESPECTIVE POWER SOURCE TO THE LIGHTING CONTACTOR PANEL. 30 AMP INPUT POWER/BRANCH CIRCUITS SHALL BE #8 AWG COPPER THWN (MIN.) FROM THE RESPECTIVE POWER SOURCE TO THE LIGHTING CONTACTOR PANEL.
 - INPUT CONTROL CIRCUITS SHALL BE #12 AWG COPPER THWN.
 - FOR 120 VAC BRANCH CIRCUITS THE NEUTRAL CONDUCTOR SHALL NOT BE SWITCHED THROUGH THE RELAY CONTACTS. USE TERMINAL BLOCKS TO TRANSITION FROM VAULT BRANCH CIRCUIT WIRING TO FIELD WIRING.
 - THE AIRPORT ROTATING BEACON CIRCUIT SHALL HAVE PHASE "A" SWITCHED THROUGH THE LIGHTING CONTACTOR. PHASE "B" SHALL BE UNSWITCHED FROM THE POWER SOURCE TO THE LOAD CENTER AT THE AIRPORT ROTATING BEACON.
 - PROVIDE #10 AWG COPPER BONDING JUMPER FROM PANEL ENCLOSURE FRAME TO ENCLOSURE DOOR.
 - PROVIDE 3-POSITION MAINTAINED CONTACT "HAND-OFF-AUTO" SELECTOR SWITCH FOR EACH LIGHTING CONTACTOR & MOUNT ON LIGHTING CONTACTOR PANEL ENCLOSURE DOOR. SELECTOR SWITCH SHALL BE SQUARE D CLASS 9001, TYPE KS43FBH13, OR APPROVED EQUAL. INCLUDE LEGEND PLATE TO IDENTIFY THE DEVICE CONTROLLED (EX: "WIND CONE" OR "AIRPORT ROTATING BEACON").
 - SEE "LIGHTING CONTACTOR SCHEMATIC" AND "EXHAUST FAN CONTROL SCHEMATIC" FOR ADDITIONAL INFORMATION ON WIRING.
 - FUSING FOR FAN CIRCUIT CONTROL WIRING SHALL BE 10 AMP, 600 VAC, BUSSMANN CATALOG FNO-R-10, OR APPROVED EQUAL, WITH FUSE BLOCKS, WITH BOX LUG TERMINALS, SIZED AS REQUIRED FOR THE RESPECTIVE APPLICATION. INCLUDE HARDWARE FOR MOUNTING. PROVIDE ONE BOX (5 MINIMUM QUANTITY) OF EACH TYPE AND SIZE OF FUSE, UPON COMPLETION OF THE JOB FOR USE AS SPARES.
 - INCLUDE LEGEND PLATE ON CONTROL PANEL ENCLOSURE OUTER DOOR LABELED "NOTICE: CONTACTORS HAVE REMOTE LOCATED CONTROLS AND MAY ACTIVATE AT ANY TIME".
 - 120/240 VAC PHASE "A" CONDUCTORS SHALL HAVE BLACK COLORED INSULATION. 120/240 VAC PHASE "B" CONDUCTORS SHALL HAVE RED COLORED INSULATION. NEUTRAL CONDUCTORS SHALL HAVE WHITE COLORED INSULATION. INSULATED EQUIPMENT GROUND WIRES SHALL HAVE GREEN COLORED INSULATION.
 - CONTROL PANEL FOR AIRFIELD NAVAIDS & VAULT FAN SHALL BE MANUFACTURED BY A UL 508 INDUSTRIAL CONTROL PANEL BUILDER OR AN FAA APPROVED L-821 PANEL BUILDER, AND SHALL BE MANUFACTURED IN THE UNITED STATES TO COMPLY WITH THE AIRPORT IMPROVEMENT PROGRAM BUY AMERICAN PREFERENCES REQUIREMENT. WHERE THE PANEL IS MANUFACTURED BY AN L-821 PANEL BUILDER IT SHALL BE LABELED AS AN L-821 PANEL.
 - CONTROL PANEL FOR AIRFIELD NAVAIDS & VAULT FAN SHALL BE SEPARATE FROM THE RELAY INTERFACE CONTROL PANEL.

CONTROL PANEL FOR AIRFIELD NAVAIDS AND VAULT FAN

REVISION					
DATE					
MARSHALL COUNTY AIRPORT LACON, ILLINOIS					
BLOCK GRANT: 3-17-0059-B14					
IL PROJ.: C75-4218					
Hanson Project No.	09A0031	LAYOUT	KNL	11/10/12	
Filename	E-606-ELE.dwg	DRAWN	THR	11/14/12	
Scale	NOT TO SCALE	REVIEWED	BSS	01/11/13	
Date	01/11/13				
© Copyright Hanson Professional Services Inc. 2012 Hanson Professional Services Inc. 1525 S. 36th St. Springfield, Illinois 62703-2886					
CONSTRUCT A 2,065' X 35' PARTIAL PARALLEL TAXIWAY TO RUNWAY 13/31					
CONTROL PANEL FOR AIRFIELD NAVAIDS AND VAULT FAN					
73					
73 of 79 sheets					

REVISION	
DATE	

MARSHALL COUNTY AIRPORT
LACON, ILLINOIS

IL PROJ.: C75-4218 BLOCK GRANT: 3-17-0059-B14

Hanson Project No.	09A0031
Filename	E-608-WRC.dwg
Scale	NOT TO SCALE
Date	01/11/13
LAYOUT	KNL 11/11/12
DRAWN	TRR 11/15/12
REVIEWED	BSS 01/11/13



CONSTRUCT A 2,065' X 35' PARTIAL PARALLEL TAXIWAY TO RUNWAY 13/31

HIGH VOLTAGE WIRING SCHEMATIC FOR RWY 13-31 & TAXIWAY

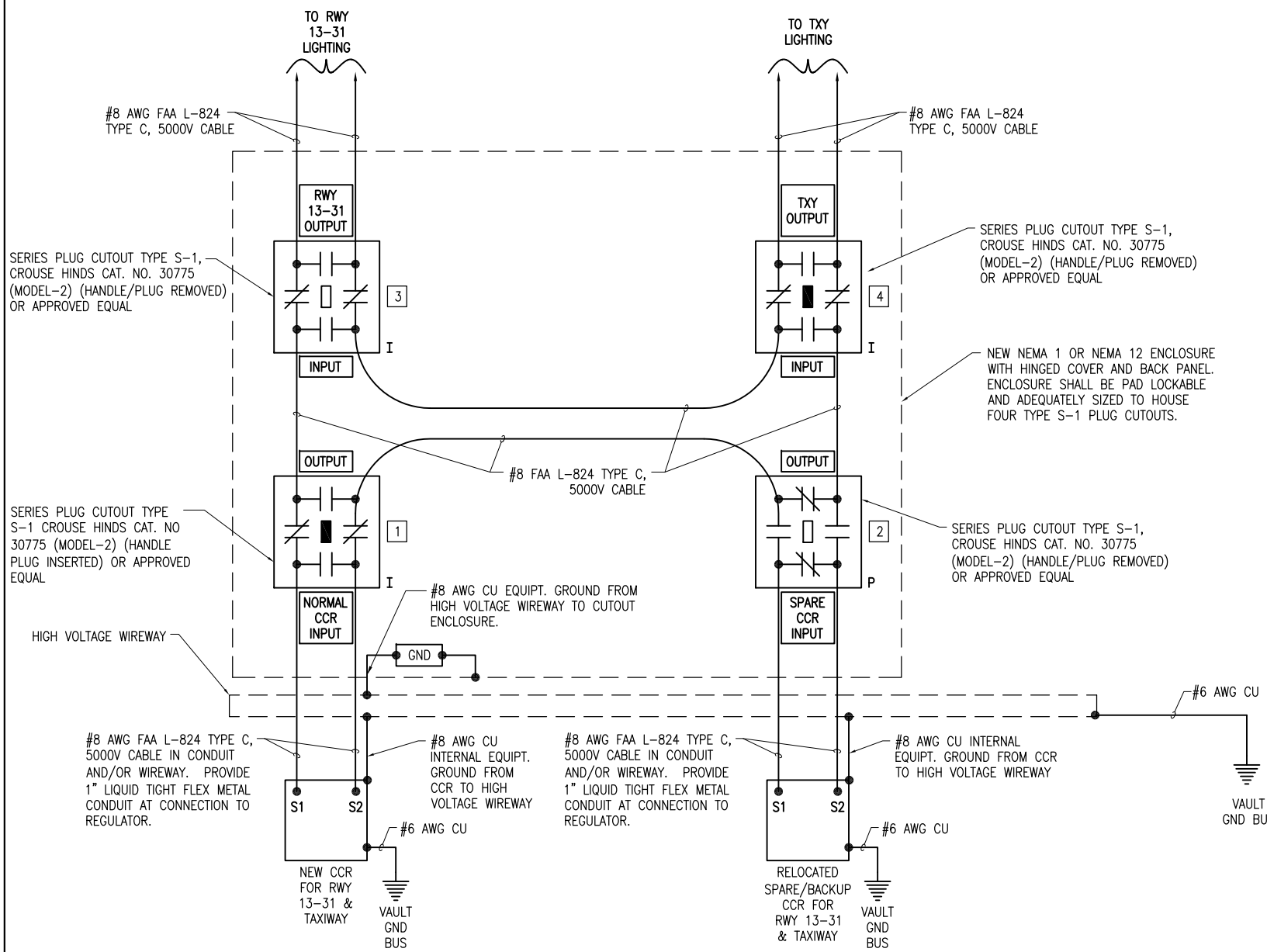

HIGH VOLTAGE WIRING SCHEMATIC FOR RUNWAY 13-31 & TAXIWAY
NOT TO SCALE

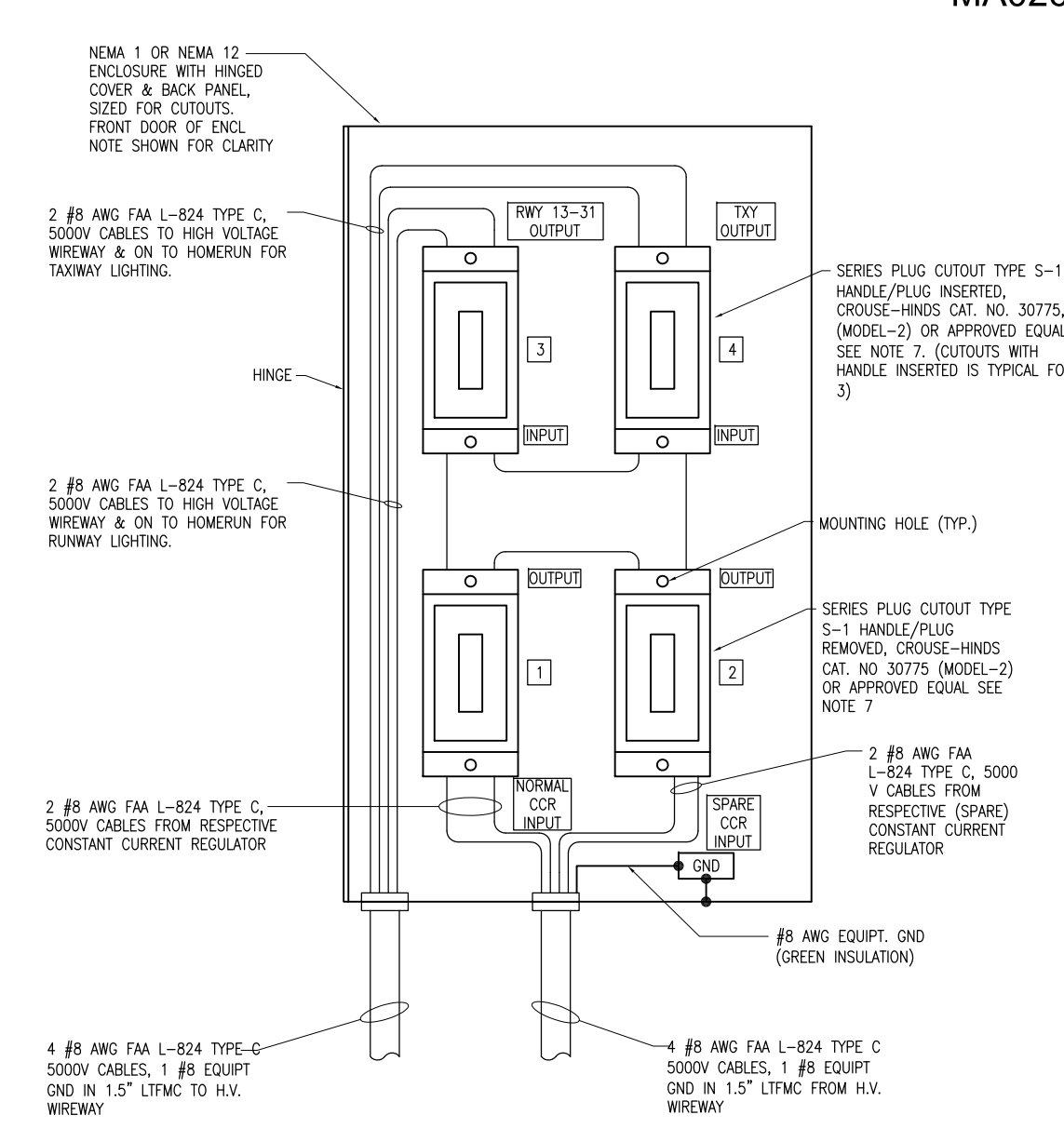

SERIES PLUG CUTOUT MOUNTING DETAIL
NOT TO SCALE

NOTES

- PROVIDE PHENOLIC ENGRAVED LEGEND PLATES FOR EACH CONSTANT CURRENT REGULATOR (EXISTING & NEW) NOTING THE RUNWAY AND/OR TAXIWAY SERVED.
- EACH PLUG CUTOUT CABINET SHALL BE FURNISHED WITH A PHENOLIC ENGRAVED LEGEND PLATE THAT IDENTIFIES THE RESPECTIVE RUNWAY OR TAXIWAY CIRCUIT OR REGULATOR. INCLUDE AN ADDITIONAL LEGEND PLATE LABELED "CAUTION OPERATE CUTOUTS WITH CCR SHUT OFF".
- PROVIDE PHENOLIC ENGRAVED LEGEND PLATES FOR THE CUTOUTS TO IDENTIFY THE RESPECTIVE REGULATOR OUTPUT CONNECTION AND THE RESPECTIVE CIRCUIT LOAD CONNECTION.
- BOND EACH REGULATOR FRAME TO VAULT GROUND BUS WITH A DEDICATED #6 AWG COPPER BONDING JUMPER.
- PROVIDE ADEQUATE WORKING SPACE IN FRONT OF EACH CUTOUT ENCLOSURE TO MEET NEC CLEARANCE REQUIREMENTS.
- LIQUID TIGHT FLEXIBLE METAL CONDUIT AND ASSOCIATED FITTINGS SHALL BE U.L. LISTED TO MEET THE REQUIREMENTS OF NEC 350.6, SUITABLE FOR GROUNDING AND SUNLIGHT RESISTANT. LIQUID TIGHT FLEXIBLE METAL CONDUIT THAT IS USED FOR FLEXIBILITY (INCLUDING CONNECTIONS TO CCR'S & TRANSFORMERS) SHALL REQUIRE AN EXTERNAL BONDING JUMPER OR INTERNAL EQUIPMENT GROUNDING CONDUCTOR PER NEC 350.60. EXTERNAL BONDING JUMPERS USED WITH CCR INSTALLATIONS SHALL BE #6 AWG COPPER (MINIMUM). DO NOT INSTALL LIQUID TIGHT FLEXIBLE METAL CONDUIT THAT IS NOT UL LISTED. CONFIRM LIQUID TIGHT FLEXIBLE METAL CONDUIT BEARS THE UL LABEL PRIOR TO INSTALLING IT.
- SERIES PLUG CUTOUTS SHALL BE TYPE S-1, RATED 5000 VOLTS, 20-AMP, AND SHALL COMPLY WITH FAA AC 150/5340-1C, SERIES PLUG CUTOUTS SHALL BE RATED SUITABLE FOR NORMAL OPERATION WITH HANDLE REMOVED OR HANDLE INSERTED. CUTOUTS SHALL DISCONNECT THE INPUT FROM THE OUTPUT, SHORT THE INPUT TERMINALS, AND SHORT THE OUTPUT TERMINALS WHEN THE HANDLE/PLUG IS REMOVED. CUTOUTS SHALL BE SUITABLE FOR MANUAL TRANSFER OPERATION (ONE SERIES CIRCUIT LOOP WITH THE CAPABILITY OF BEING POWERED FROM EITHER OF TWO CONSTANT CURRENT REGULATOR POWER SOURCES). SERIES PLUG CUTOUTS SHALL BE CROUSE-HINDS CAT. NO. 30775, OR APPROVED EQUAL THE RESPECTIVE MANUFACTURER SHALL CERTIFY IN WRITING THAT THEIR CUTOUT IS SUITABLE AND RATED FOR THE RESPECTIVE APPLICATION.
- HIGH VOLTAGE & LOW VOLTAGE CIRCUITS SHALL NOT BE INSTALLED IN THE SAME WIREWAY, CONDUIT, HANDHOLE, JUNCTION BOX, OR RACEWAY.

LEGEND

- "I" DENOTES PLUG CUTOUT WITH PLUG INSERTED
- "P" DENOTES PLUG CUTOUT WITH PLUG PULLED
- "CCR" DENOTES CONSTANT CURRENT REGULATOR

JAN 11, 2013 1:21 PM HARR01115
 pw:\sps-sv306\hanson\Documents\09A0031\09A0031D\CAD\Airport\Sheet\E-608-WRC

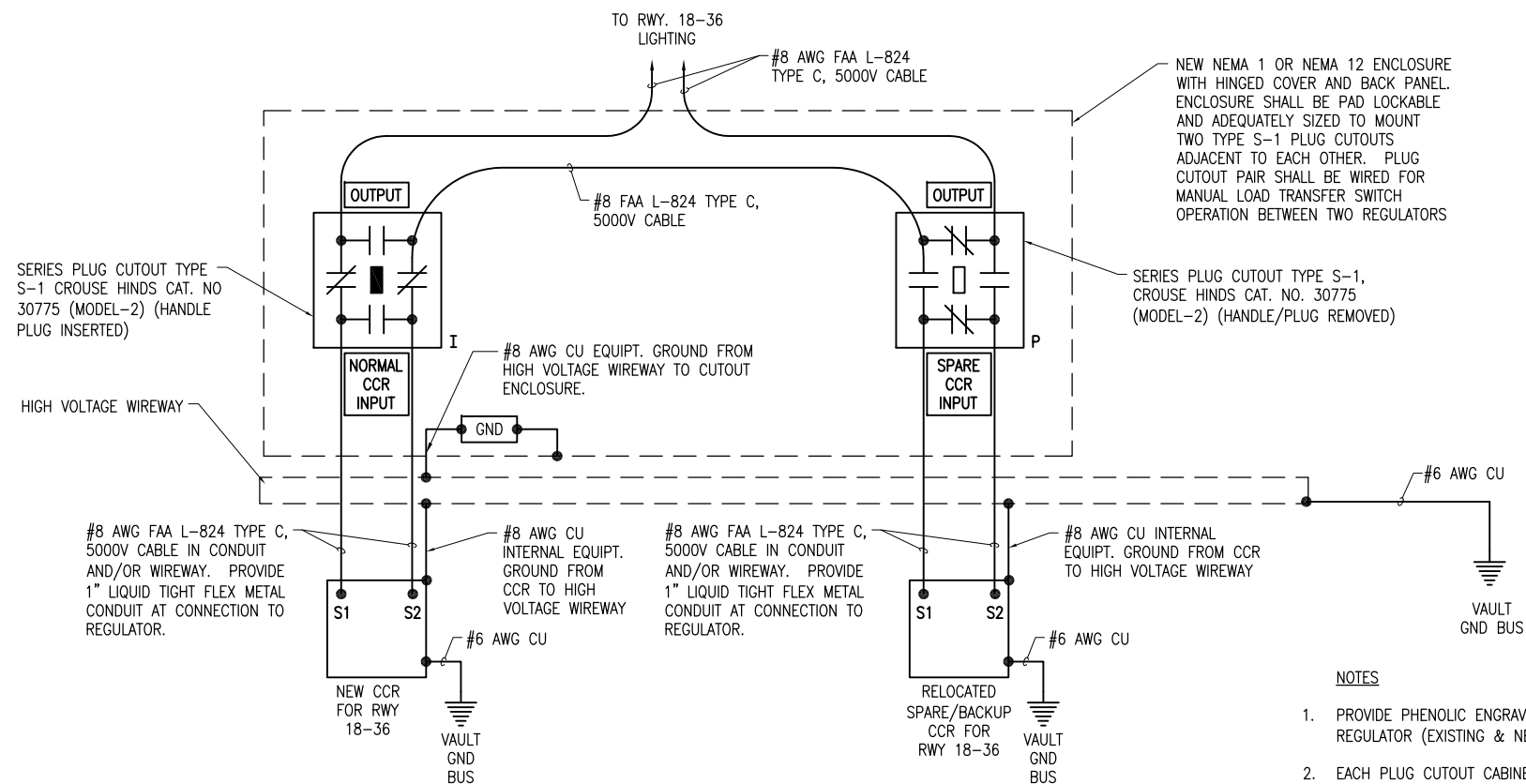

HIGH VOLTAGE WIRING SCHEMATIC FOR RUNWAY 18-36

NOT TO SCALE

NOTES

1. PROVIDE PHENOLIC ENGRAVED LEGEND PLATES FOR EACH CONSTANT CURRENT REGULATOR (EXISTING & NEW) NOTING THE RUNWAY AND/OR TAXIWAY SERVED.
2. EACH PLUG CUTOUT CABINET SHALL BE FURNISHED WITH A PHENOLIC ENGRAVED LEGEND PLATE THAT IDENTIFIES THE RESPECTIVE RUNWAY OR TAXIWAY CIRCUIT OR REGULATOR. INCLUDE AN ADDITIONAL LEGEND PLATE LABELED "CAUTION OPERATE CUTOUTS WITH CCR SHUT OFF".
3. PROVIDE PHENOLIC ENGRAVED LEGEND PLATES FOR THE CUTOUTS TO IDENTIFY THE RESPECTIVE REGULATOR OUTPUT CONNECTION AND THE RESPECTIVE CIRCUIT LOAD CONNECTION.
4. BOND EACH REGULATOR FRAME TO VAULT GROUND BUS WITH A DEDICATED #6 AWG COPPER BONDING JUMPER.
5. PROVIDE ADEQUATE WORKING SPACE IN FRONT OF EACH CUTOUT ENCLOSURE TO MEET NEC CLEARANCE REQUIREMENTS.
6. LIQUID TIGHT FLEXIBLE METAL CONDUIT AND ASSOCIATED FITTINGS SHALL BE U.L. LISTED TO MEET THE REQUIREMENTS OF NEC 350.6, SUITABLE FOR GROUNDING AND SUNLIGHT RESISTANT. LIQUID TIGHT FLEXIBLE METAL CONDUIT THAT IS USED FOR FLEXIBILITY (INCLUDING CONNECTIONS TO CCR'S & TRANSFORMERS) SHALL REQUIRE AN EXTERNAL BONDING JUMPER OR INTERNAL EQUIPMENT GROUNDING CONDUCTOR PER NEC 350.60. EXTERNAL BONDING JUMPERS USED WITH CCR INSTALLATIONS SHALL BE #6 AWG COPPER (MINIMUM). DO NOT INSTALL LIQUID TIGHT FLEXIBLE METAL CONDUIT THAT IS NOT UL LISTED. CONFIRM LIQUID TIGHT FLEXIBLE METAL CONDUIT BEARS THE UL LABEL PRIOR TO INSTALLING IT.
7. SERIES PLUG CUTOUTS SHALL BE TYPE S-1, RATED 5000 VOLTS, 20-AMP, AND SHALL COMPLY WITH FAA AC 150/5340-4C. SERIES PLUG CUTOUTS SHALL BE RATED SUITABLE FOR NORMAL OPERATION WITH HANDLE REMOVED OR HANDLE INSERTED. CUTOUTS SHALL DISCONNECT THE INPUT FROM THE OUTPUT, SHORT THE INPUT TERMINALS, AND SHORT THE OUTPUT TERMINALS WHEN THE HANDLE/PLUG IS REMOVED. CUTOUTS SHALL BE SUITABLE FOR MANUAL TRANSFER OPERATION (ONE SERIES CIRCUIT LOOP WITH THE CAPABILITY OF BEING POWERED FROM EITHER OF TWO CONSTANT CURRENT REGULATOR POWER SOURCES). SERIES PLUG CUTOUTS SHALL BE CROUSE-HINDS CAT. NO. 30775, OR APPROVED EQUAL THE RESPECTIVE MANUFACTURER SHALL CERTIFY IN WRITING THAT THEIR CUTOUT IS SUITABLE AND RATED FOR THE RESPECTIVE APPLICATION.
8. HIGH VOLTAGE & LOW VOLTAGE CIRCUITS SHALL NOT BE INSTALLED IN THE SAME WIREWAY, CONDUIT, HANDHOLE, JUNCTION BOX, OR RACEWAY.

LEGEND

- "I" DENOTES PLUG CUTOUT WITH PLUG INSERTED
- "P" DENOTES PLUG CUTOUT WITH PLUG PULLED
- "CCR" DENOTES CONSTANT CURRENT REGULATOR

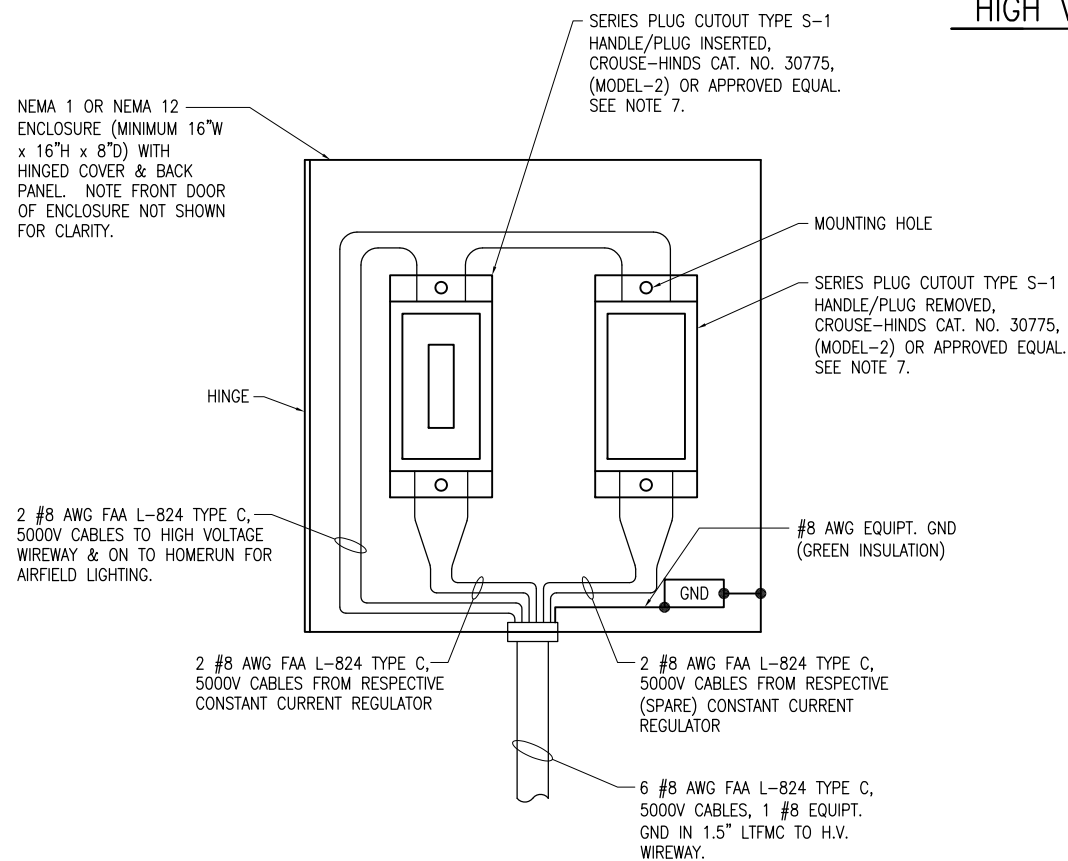

SERIES PLUG CUTOUT MOUNTING DETAIL FOR RUNWAY CIRCUIT

NOT TO SCALE

REVISION	DATE

MARSHALL COUNTY AIRPORT
LACON, ILLINOIS

IL PROJ.: C75-4218 BLOCK GRANT: 3-17-0059-B14

Hanson Project No.	09A0031
Filename	E-609-WRG.dwg
Scale	NOT TO SCALE
Date	01/11/13
LAYOUT	KNL 11/11/12
DRAWN	MLH 11/11/12
REVIEWED	BSS 01/11/13



CONSTRUCT A 2,065' X 35' PARTIAL PARALLEL TAXIWAY TO RUNWAY 13/31
HIGH VOLTAGE WIRING SCHEMATIC FOR RUNWAY 18-36

JAN 11, 2013 1:21 PM HARR01115 p:\s\svr306\hanson\Documents\09\jobs\09A0031\09A0031D\CAD\Airport\Sheet\E-609-WRG

LEGEND PLATE SCHEDULE	
DEVICE	LABEL
VAULT SERVICE DISTRIBUTION PANELBOARD	VAULT SERVICE & DISTRIBUTION PANEL 120/240 VAC, 1 PH, 3W
MAIN BREAKER IN VAULT PANEL	SERVICE DISCONNECT
RUNWAY 13-31 CCR	RUNWAY 13-31 & TAXIWAY
BACKUP/SPARE CCR FOR RUNWAY 13-31	SPARE FOR RUNWAY 13-31 & TAXIWAY
RUNWAY 18-36 CCR	RUNWAY 18-36
BACKUP/SPARE CCR FOR RUNWAY 18-36	SPARE FOR RUNWAY 18-36
CUTOUT ENCLOSURE FOR RUNWAY 13-31	RUNWAY 13-31 & TAXIWAY CUTOUTS
RUNWAY 13-31 CUTOUT #1 (NORMAL CCR INPUT)	#1
RUNWAY 13-31 CUTOUT #2 (SPARE CCR INPUT)	#2
RUNWAY 13-31 CUTOUT #3	#3
TAXIWAY CUTOUT #4	#4
RUNWAY 13-31 CUTOUT #1 INPUT SIDE CONNECTION	NORMAL CCR INPUT
RUNWAY 13-31 CUTOUT #2 INPUT SIDE CONNECTION	SPARE CCR INPUT
RUNWAY 13-31 CUTOUT #3 INPUT SIDE CONNECTION	INPUT
TAXIWAY CUTOUT #4 INPUT SIDE CONNECTION	INPUT
RUNWAY 13-31 CUTOUT #1 OUTPUT SIDE CONNECTION	OUTPUT
RUNWAY 13-31 CUTOUT #2 OUTPUT SIDE CONNECTION	OUTPUT
RUNWAY 13-31 CUTOUT #3 OUTPUT SIDE CONNECTION	RWY 13-31 OUTPUT
TAXIWAY CUTOUT #4 OUTPUT SIDE CONNECTION	TAXIWAY OUTPUT
CUTOUT ENCLOSURE FOR RUNWAY 18-36	RUNWAY 18-36 CUTOUTS
NORMAL CUTOUT INPUT SIDE CONNECTION FOR RUNWAY 18-36	NORMAL CCR INPUT
SPARE CUTOUT INPUT SIDE CONNECTION FOR RUNWAY 18-36	SPARE CCR INPUT
EACH CUTOUT (RUNWAY 18-36) OUTPUT SIDE CONNECTION (2 LEGEND PLATES)	OUTPUT

LEGEND PLATE SCHEDULE CONTINUED	
DEVICE	LABEL
EACH CUTOUT ENCLOSURE (2 LEGEND PLATES)	CAUTION OPERATE CUTOUTS WITH CCR'S SHUT OFF
RADIO RELAY INTERFACE PANEL	RADIO RELAY INTERFACE PANEL
MANUAL TRANSFER SWITCH FOR RUNWAY 13-31 NORMAL CCR AND SPARE/BACKUP CCR	TRANSFER SWITCH FOR RUNWAY 13-31 CONSTANT CURRENT REGULATORS
MANUAL TRANSFER SWITCH FOR RUNWAY 13-31 NORMAL CCR AND SPARE/BACKUP CCR - NORMAL SWITCH POSITION	NORMAL CCR
MANUAL TRANSFER SWITCH FOR RUNWAY 13-31 NORMAL CCR AND SPARE/BACKUP CCR - BACKUP SWITCH POSITION	SPARE/BACKUP CCR
MANUAL TRANSFER SWITCH FOR RUNWAY 18-36 NORMAL CCR AND SPARE/BACKUP CCR	TRANSFER SWITCH FOR RUNWAY 18-36 CONSTANT CURRENT REGULATORS
MANUAL TRANSFER SWITCH FOR RUNWAY 18-36 NORMAL CCR AND SPARE/BACKUP CCR - NORMAL SWITCH POSITION	NORMAL CCR
MANUAL TRANSFER SWITCH FOR RUNWAY 18-36 NORMAL CCR AND SPARE/BACKUP CCR - BACKUP SWITCH POSITION	SPARE/BACKUP CCR
CONTROL PANEL FOR AIRFIELD NAVAIDS AND VAULT FAN	CONTACTOR PANEL FOR AIRFIELD NAVAIDS, & VAULT FAN
CONTROL PANEL FOR AIRFIELD NAVAIDS AND VAULT FAN	NOTICE CONTACTORS HAVE REMOTE LOCATED CONTROLS AND MAY ACTIVATE AT ANY TIME
LOW VOLTAGE WIREWAY (PROVIDE 9 LEGEND PLATES 1/2" HIGH BLACK LETTERS WHITE BACKGROUND)	LOW VOLTAGE
HIGH VOLTAGE WIREWAY (PROVIDE 6 LEGEND PLATES 1/2" HIGH BLACK LETTERS WHITE BACKGROUND)	HIGH VOLTAGE
VAULT GROUND BUS (PROVIDE 4 LEGEND PLATES 1/2" HIGH WHITE LETTERS GREEN BACKGROUND; INSTALL ABOVE OR BELOW GROUND BUS)	VAULT GROUND BUS
GROUNDING ELECTRODE CONDUCTORS TERMINATED ON VAULT GROUND BUS. (PROVIDE 3 LEGEND PLATES & SECURE TO CONDUCTORS WITH NYLON STRING OR CABLE TIES)	DO NOT DISCONNECT

- DIRECTIONS TO TRANSFER RUNWAY 18-36 LIGHTING FROM NORMAL CCR TO SPARE/BACKUP CCR.
- SHUT OFF INPUT POWER (CIRCUIT BREAKER) TO BOTH RWY 18-36 CCR'S & TURN CCR SELECTOR SWITCHES TO OFF.
 - OPERATE MANUAL TRANSFER SWITCH FOR RWY 18-36 AND MOVE HANDLE FROM "NORMAL" POSITION TO "SPARE/BACKUP" POSITION.
 - PULL CUTOUT HANDLE FROM NORMAL CCR UNIT & INSERT INTO SPARE CCR CUTOUT.
 - GO TO RADIO RELAY INTERFACE PANEL & TURN "RWY 18-36 CCR TRANSFER" SELECTOR SWITCH FROM "NORMAL" TO "SPARE" POSITION.
 - TURN ON INPUT POWER (CIRCUIT BREAKER) TO SPARE RWY 18-36 CCR.
 - TURN SELECTOR SWITCH ON SPARE CCR TO "REMOTE" POSITION.

PROVIDE PLACARD OR LEGEND PLATE FOR RUNWAY CONSTANT CURRENT REGULATOR PAIR AS NOTED ABOVE: LETTERING TO BE MIN. 1/4" HIGH, BLACK ON WHITE BACKGROUND. LOCATE PLACARD ABOVE OR ADJACENT TO CUTOUT ENCLOSURE FOR RESPECTIVE RUNWAY.

**RUNWAY 18-36 CCR TRANSFER PROCEDURE
PLACARD DETAIL**



"DANGER - HIGH VOLTAGE KEEP OUT" SIGN

PROVIDE WARNING SIGN ON VAULT EXTERIOR DOORS LABELED "DANGER - HIGH VOLTAGE - KEEP OUT" PER THE REQUIREMENTS OF NEC 110.34 (C). PROVIDE MINIMUM OF 2 SIGNS (ONE ON EACH DOOR TO THE VAULT). SIGNS SHALL BE APPROXIMATELY 10" X 14"W.

- DIRECTIONS TO TRANSFER RUNWAY 13-31 LIGHTING FROM NORMAL CCR TO SPARE/BACKUP CCR.
- SHUT OFF INPUT POWER (CIRCUIT BREAKER) TO BOTH RWY 13-31 CCR'S & TURN CCR SELECTOR SWITCHES TO OFF.
 - OPERATE MANUAL TRANSFER SWITCH FOR RWY 13-31 AND MOVE HANDLE FROM "NORMAL" POSITION TO "SPARE/BACKUP" POSITION.
 - PULL CUTOUT HANDLE FROM NORMAL CCR UNIT (CUTOUT #1) & INSERT INTO SPARE CCR CUTOUT (CUTOUT #2).
 - GO TO RADIO RELAY INTERFACE PANEL & TURN "RWY 13-31 CCR TRANSFER" SELECTOR SWITCH FROM "NORMAL" TO "SPARE" POSITION.
 - TURN ON INPUT POWER (CIRCUIT BREAKER) TO SPARE RWY 13-31 CCR.
 - TURN SELECTOR SWITCH ON SPARE CCR TO "REMOTE" POSITION.

PROVIDE PLACARD OR LEGEND PLATE FOR RUNWAY CONSTANT CURRENT REGULATOR PAIR AS NOTED ABOVE: LETTERING TO BE MIN. 1/4" HIGH, BLACK ON WHITE BACKGROUND. LOCATE PLACARD ABOVE OR ADJACENT TO CUTOUT ENCLOSURE FOR RESPECTIVE RUNWAY.

**RUNWAY 13-31 CCR TRANSFER PROCEDURE
PLACARD DETAIL**

NOTE: LEGEND PLATES SHALL BE WEATHERPROOF ENGRAVED PLASTIC OR PHENOLIC MATERIAL, 1/4" HIGH BLACK LETTERS ON A WHITE BACKGROUND UNLESS NOTED OTHERWISE. SECURE WITH WEATHERPROOF ADHESIVE AND MACHINE SCREWS. FURNISH ADDITIONAL LEGEND PLATES WHERE REQUIRED BY CODE, FOR ADDITIONAL EQUIPMENT, AS DETAILED HEREIN ON THE PLANS, AND AS NOTED IN THE SPECIAL PROVISION SPECIFICATIONS.

FURNISH & INSTALL A WEATHERPROOF WARNING LABEL FOR EACH SAFETY SWITCH, PANELBOARD, LOAD CENTER, CUTOUT, & CONTROL PANEL TO WARN PERSONS OF POTENTIAL ELECTRIC ARC FLASH HAZARDS, PER THE REQUIREMENTS OF NEC 110.16 "FLASH PROTECTION". LABELS SHALL BE HAZARD COMMUNICATION SYSTEMS, LLC (190 OLD MILFORD RD., BOX 1174, MILFORD, PA 18337, PHONE: 1-877-748-0244) PART NO. H6010-9VWHBJ OR APPROVED EQUAL.



"DANGER - HIGH VOLTAGE" SIGN

FURNISH AND INSTALL "DANGER - HIGH VOLTAGE" LABELS/SIGNS FOR EACH CUTOUT ENCLOSURE, EACH CONSTANT CURRENT REGULATOR, AND THE HIGH VOLTAGE WIREWAY, TO COMPLY WITH FAA AC 150/5340-26B "MAINTENANCE OF AIRPORT VISUAL AID FACILITIES". LABELS SHALL BE APPROXIMATELY 4" X 6" OR 5" X 7".

REVISION		DATE	
MARSHALL COUNTY AIRPORT LACON, ILLINOIS			
BLOCK GRANT: 3-17-0059-B14			
IL PROJ.: C75-4218			
Hanson Project No.	09A0031	LAYOUT	11/10/12
Filename	E-612-SCH.dwg	DRAWN	MLH
Scale	NOT TO SCALE	REVIEWED	BSS
Date	01/11/13		01/11/13
HANSON		© Copyright Hanson Professional Services Inc. 2013 Hanson Professional Services Inc. 1525 S. 36th St. Springfield, Illinois 62703-2886	
CONSTRUCT A 2,065' X 35' PARTIAL PARALLEL TAXIWAY TO RUNWAY 13/31		LEGEND PLATE SCHEDULES	
76		76 of 79 sheets	

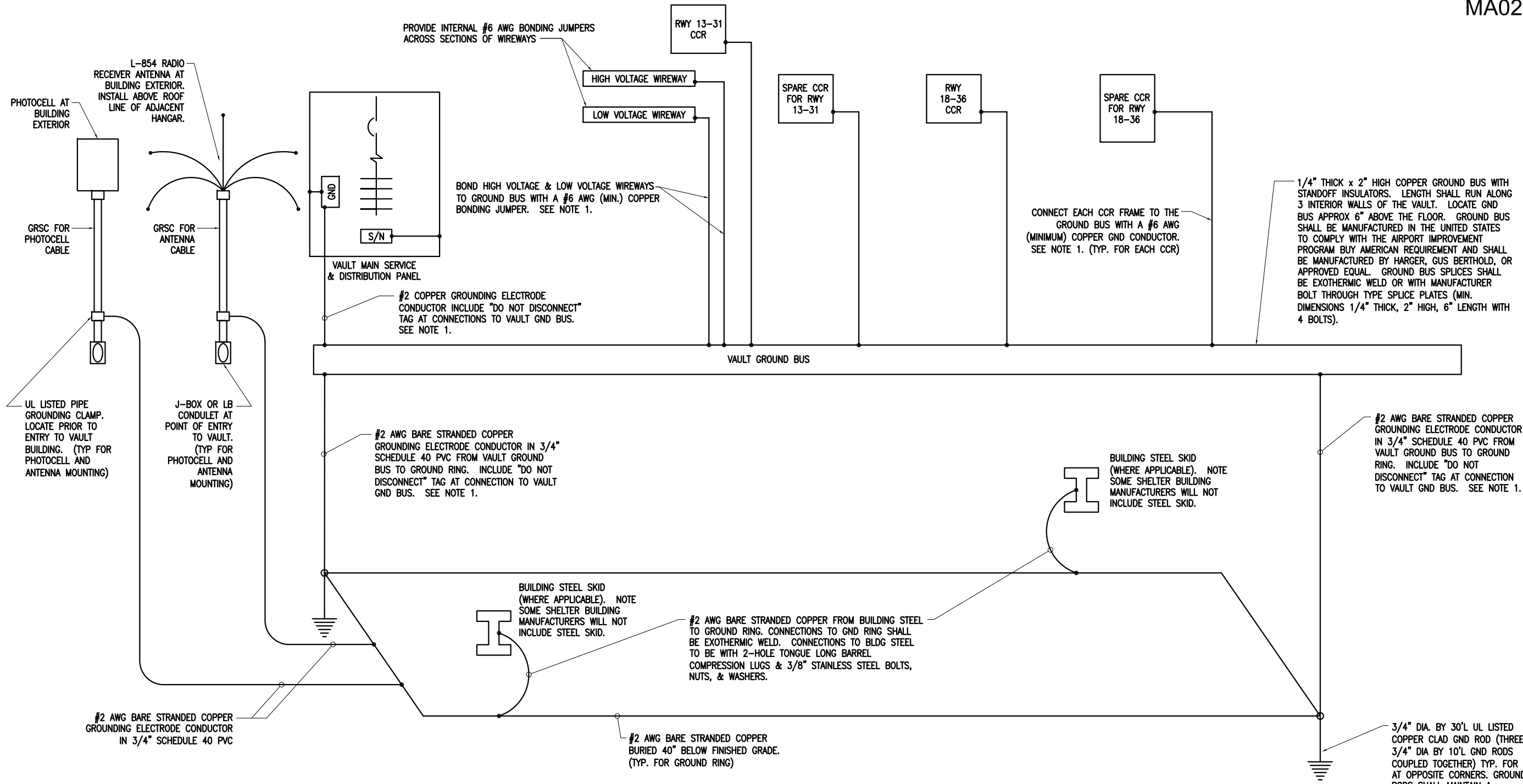

VAULT GROUND BUS RISER

- NOTES**
1. CONNECTIONS TO GROUND BUS BAR SHALL BE WITH 2-HOLE TONGUE LONG BARREL COMPRESSION LUGS BOLTED TO THE BUS BAR.
 2. ALL CONNECTIONS TO THE GROUND RING AND GROUND RODS SHALL BE EXOTHERMIC WELD.
 3. ALL INSULATED GROUND WIRES SHALL HAVE GREEN COLORED INSULATION FOR ALL CONDUCTOR AWG AND KCMIL.
 4. ALL WORK SHOWN ON THIS SHEET SHALL BE PAID FOR UNDER ITEM AR109200 "INSTALL ELECTRICAL EQUIPMENT" PER LUMP SUM.
 5. TEST GROUND RING AND RECORD RESULTS. WHERE GROUND RESISTANCE TEST RESULTS EXCEED 25 OHMS CONTACT PROJECT ENGINEER FOR FURTHER DIRECTION.

REVISION	DATE

MARSHALL COUNTY AIRPORT
LACON, ILLINOIS

IL PROJ.: C75-4218
BLOCK GRANT: 3-17-0059-B14

Hanson Project No.	09A0031
Filename	E-610-DIA.dwg
Scale	NOT TO SCALE
Date	01/11/13
LAYOUT	KNL 11/11/12
DRAWN	MLH 11/11/12
REVIEWED	BSS 01/11/13

© Copyright Hanson Professional Services Inc. 2012
Hanson Professional Services Inc.
1525 South Main Street
Springfield, Illinois 62703-2886

CONSTRUCT A 2,065' X 35'
PARTIAL PARALLEL TAXIWAY
TO RUNWAY 13/31

VAULT GROUND BUS RISER

JAN 11, 2013 1:21 PM HARR01115
pw:\sps-svr306\hanson\Documents\09\obs\09A0031\09A0031D\CAD\Airport\Sheet\E-610-DIA

GROUNDING NOTES

- THE CONTRACTOR SHALL FURNISH AND INSTALL ALL GROUNDING AS MAY BE NECESSARY OR REQUIRED TO MAKE A COMPLETE GROUNDING SYSTEM AS REQUIRED BY THE LATEST NATIONAL ELECTRICAL CODE (NFPA 70) IN FORCE AND FAA-STD-019a (LIGHTNING AND SURGE PROTECTION, GROUNDING, BONDING, AND SHIELDING REQUIREMENTS FOR FACILITIES AND ELECTRONIC EQUIPMENT). THE RELIABILITY OF THE GROUNDING SYSTEM IS DEPENDENT ON CAREFUL, PROPER INSTALLATION AND CHOICE OF MATERIALS. IMPROPER PREPARATION OF SURFACES TO BE JOINED TO MAKE AN ELECTRICAL PATH, LOOSE JOINTS OR CORROSION CAN INTRODUCE IMPEDANCE THAT WILL SERIOUSLY IMPAIR THE ABILITY OF THE GROUND PATH TO PROTECT PERSONNEL AND EQUIPMENT AND TO ABSORB TRANSIENTS THAT CAN CAUSE NOISE IN COMMUNICATIONS CIRCUITS. THE FOLLOWING FUNCTIONS ARE PARTICULARLY IMPORTANT TO ENSURE A RELIABLE GROUND SYSTEM:
- FURNISH AND INSTALL GROUND RODS AS DETAILED HEREIN. GROUND RODS FOR AIRFIELD LIGHTING (RUNWAY LIGHTING, TAXIWAY LIGHTING, TAXI GUIDANCE SIGNS, & DISTANCE REMAINING SIGNS) SHALL BE MINIMUM 3/4-IN. DIAMETER BY 20-FT LONG, UL-LISTED COPPER CLAD WITH 10-MIL MINIMUM COPPER COATING (TWO 3/4-IN. DIAMETER BY 10-FT LONG, UL-LISTED, COPPER CLAD GROUND RODS COUPLED TOGETHER). GROUND RODS FOR OTHER APPLICATIONS SHALL BE MINIMUM 3/4-IN. DIAMETER BY 20-FT LONG, UL-LISTED, COPPER CLAD WITH 10-MIL MINIMUM COPPER COATING. GROUND RODS SHALL BE SPACED OR AS DETAILED ON THE RESPECTIVE PLANS, AND IN NO CASE SPACED LESS THAN ONE ROD LENGTH APART. ALL CONNECTIONS TO GROUND RODS AND THE GROUND RING SHALL BE MADE WITH EXOTHERMIC WELD TYPE CONNECTORS, CADWELD BY ERICO PRODUCTS, INC., SOLON, OHIO, (PHONE 1-800-248-9353), THERMOWELD BY CONTINENTAL INDUSTRIES, INC., TULSA, OKLAHOMA (PHONE 918-663-1440), ULTRAWELD BY HARGER, GRAYSLAKE, ILLINOIS (PHONE 1-800-842-7437), OR APPROVED EQUAL. EXOTHERMIC WELD CONNECTIONS SHALL BE INSTALLED IN CONFORMANCE WITH THE RESPECTIVE MANUFACTURER'S DIRECTIONS USING MOLDS AS REQUIRED FOR EACH RESPECTIVE APPLICATION. BOLTED CONNECTIONS WILL NOT BE PERMITTED AT GROUND RODS OR AT BURIED GROUNDING ELECTRODE CONDUCTORS.
- CONTRACTOR SHALL TEST EACH MADE ELECTRODE GROUND ROD/GROUND FIELD/GROUND RING WITH AN INSTRUMENT SPECIFICALLY DESIGNED FOR TESTING GROUND FIELD SYSTEMS. IF GROUND RESISTANCE EXCEEDS 25 OHMS, CONTACT THE PROJECT ENGINEER FOR FURTHER DIRECTION. COPIES OF GROUND ROD TEST RESULTS SHALL BE FURNISHED TO THE RESIDENT ENGINEER/RESIDENT PROJECT REPRESENTATIVE, UPON REQUEST, FOR REVIEW AND RECORD PURPOSES.
- ALL PRODUCTS ASSOCIATED WITH THE GROUNDING SYSTEM SHALL BE UL-LISTED AND LABELED.
- ALL BOLTED OR MECHANICAL CONNECTIONS SHALL BE COATED WITH A CORROSION PREVENTATIVE COMPOUND BEFORE JOINING, SANCHEM INC. 'NO-OX-ID 'A-SPECIAL' COMPOUND, BURNDY PENETROX E, OR EQUAL.
- METALLIC SURFACES TO BE JOINED SHALL BE PREPARED BY THE REMOVAL OF ALL NON-CONDUCTIVE MATERIAL, PER 2011 NATIONAL ELECTRICAL CODE ARTICLE 250-12. ALL COPPER BUS BARS MUST BE CLEANED PRIOR TO MAKING CONNECTIONS TO REMOVE SURFACE OXIDATION.
- METALLIC RACEWAY FITTINGS SHALL BE MADE UP TIGHT TO PROVIDE A PERMANENT LOW IMPEDANCE PATH FOR ALL CIRCUITS. METAL CONDUIT TERMINATIONS IN ENCLOSURES SHALL BE BONDED TO THE ENCLOSURE WITH UL-LISTED FITTINGS SUITABLE FOR GROUNDING. PROVIDE GROUNDING BUSHINGS WITH BONDING JUMPERS FOR ALL METAL CONDUITS ENTERING SERVICE EQUIPMENT (METER BASE, CT CABINET, MAIN SERVICE BREAKER ENCLOSURE, ETC.). PROVIDE GROUNDING BUSHINGS WITH BONDING JUMPERS FOR ALL METAL CONDUITS ENTERING AN ENCLOSURE THROUGH CONCENTRIC OR ECCENTRIC KNOCKOUTS THAT ARE PUNCHED OR OTHERWISE FORMED SO AS TO IMPAIR THE ELECTRICAL CONNECTION TO GROUND. STANDARD LOCKNUTS OR BUSHINGS SHALL NOT BE THE SOLE MEANS FOR BONDING WHERE A CONDUIT ENTERS AN ENCLOSURE THROUGH A CONCENTRIC OR ECCENTRIC KNOCKOUT
- ALL CONNECTIONS, LOCATED ABOVE GRADE, BETWEEN THE DIFFERENT TYPES OF GROUNDING CONDUCTORS SHALL BE MADE USING UL-LISTED DOUBLE COMPRESSION CRIMP TYPE CONNECTORS OR UL-LISTED BOLTED GROUND CONNECTORS. FOR GROUND CONNECTIONS TO ENCLOSURES, CASES AND FRAMES OF ELECTRICAL EQUIPMENT NOT SUPPLIED WITH GROUND LUGS THE CONTRACTOR SHALL DRILL REQUIRED HOLES FOR MOUNTING A BOLTED GROUND CONNECTOR. ALL BOLTED GROUND CONNECTORS SHALL BE BURNDY, THOMAS AND BETTS, OR EQUAL. TIGHTEN CONNECTIONS TO COMPLY WITH TIGHTENING TORQUES IN UL STANDARD 486A TO ASSURE PERMANENT AND EFFECTIVE GROUNDING.
- ALL METAL EQUIPMENT ENCLOSURES, CONDUITS, CABINETS, BOXES, RECEPTACLES, MOTORS, ETC. SHALL BE BONDED TO THE RESPECTIVE GROUNDING SYSTEM.
- PROVIDE ALL BOXES FOR PROPOSED OUTLETS, SWITCHES, CIRCUIT BREAKERS, ETC. WITH GROUNDING SCREWS. PROVIDE ALL PANELBOARD, SWITCHGEAR, ETC., ENCLOSURES WITH GROUNDING BARS WITH INDIVIDUAL SCREWS, LUGS, CLAMPS, ETC., FOR EACH OF THE GROUNDING CONDUCTORS THAT ENTER THEIR RESPECTIVE ENCLOSURES.
- EACH NEW FEEDER CIRCUIT AND/OR BRANCH CIRCUIT SHALL INCLUDE AN EQUIPMENT GROUND WIRE. METAL RACEWAY OR CONDUIT SHALL NOT MEET THIS REQUIREMENT. THE EQUIPMENT GROUND WIRE FROM EQUIPMENT SHALL NOT BE SMALLER THAN ALLOWED BY 2011 NEC TABLE 250-122 "MINIMUM SIZE CONDUCTORS OR GROUNDING RACEWAY AND EQUIPMENT." WHEN CONDUCTORS ARE ADJUSTED IN SIZE TO COMPENSATE FOR VOLTAGE DROP, EQUIPMENT-GROUNDING CONDUCTORS SHALL BE ADJUSTED PROPORTIONATELY ACCORDING TO CIRCULAR MIL AREA. ALL EQUIPMENT GROUND WIRES SHALL BE COPPER, EITHER BARE OR INSULATED GREEN IN COLOR. WHERE THE EQUIPMENT GROUNDING CONDUCTORS ARE INSULATED, THEY SHALL BE IDENTIFIED BY THE COLOR GREEN, AND SHALL BE THE SAME INSULATION TYPE AS THE PHASE CONDUCTORS.
- ALL EXTERIOR METAL CONDUIT, WHERE NOT ELECTRICALLY CONTINUOUS BECAUSE OF MANHOLES, HANDHOLES, NON-METALLIC JUNCTION BOXES, ETC., SHALL BE BONDED TO ALL OTHER METAL CONDUIT IN THE RESPECTIVE DUCT RUN, AND AT EACH END, WITH A COPPER-BONDING JUMPER SIZED IN CONFORMANCE WITH 2011 NEC 250-102. WHERE METAL CONDUITS TERMINATE IN AN ENCLOSURE (SUCH AS A MOTOR CONTROL CENTER, SWITCHBOARD, ETC) WHERE THERE IS NOT ELECTRICAL CONTINUITY WITH THE CONDUIT AND THE RESPECTIVE ENCLOSURE, PROVIDE A BONDING JUMPER FROM THE RESPECTIVE ENCLOSURE GROUND BUS TO THE CONDUIT SIZED PER 2011 NEC 250-102.
- IT IS THE INTENT OF THIS SPECIFICATION THAT ALL MOTOR FRAMES, PUMP BASES ELECTRICAL EQUIPMENT ENCLOSURES, PANEL HOUSINGS, CONDUITS, BOXES, ETC. HAVE A CONTINUOUS COPPER WIRE GROUND CONNECTION AND SHALL BE POSITIVELY BONDED TO THE RESPECTIVE GROUNDING SYSTEM. CONDUIT CONNECTORS WILL NOT BE CONSIDERED AS ADEQUATE GROUNDING.
- PROVIDE A POSITIVE GROUND BOND FOR ALL OUTLET BOXES, ELECTRICAL EQUIPMENT ENCLOSURES, GROUNDING RECEPTACLES, TOGGLE SWITCHES, ETC. INSTALL A GROUNDING CONDUCTOR IN ALL WIRE AND CABLE RACEWAYS. GROUND CONDUCTOR TO HAVE 600-VOLT INSULATION AND BE IDENTIFIED BY A CONTINUOUS GREEN COLOR COATING. THEY SHALL BE USED SOLELY FOR GROUNDING PURPOSES AND BE ENTIRELY SEPARATE FROM WHITE GROUND NEUTRAL CONDUCTOR, EXCEPT AT SUPPLY SIDE OF SERVICE DISCONNECTING MEANS, WHERE GROUNDING AND NEUTRAL SYSTEMS ARE TO BE CONNECTED TO SERVICE GROUND.
- EACH AND ALL GROUND CASED AND METAL PARTS ASSOCIATED WITH ELECTRICAL EQUIPMENT SHALL BE TESTED FOR CONTINUITY OF CONNECTION WITH GROUND BUS SYSTEM BY CONTRACTOR IN PRESENCE OF OWNER'S REPRESENTATIVE.
- ALL CONNECTIONS BETWEEN THE DIFFERENT TYPES OF GROUNDING CONDUCTORS ABOVE GRADE SHALL BE MADE USING BOLTED GROUND CONNECTORS. GROUND LUGS SHALL BE PROVIDED IN ALL ENCLOSURES AND WIRING TERMINATION JUNCTION BOXES. EQUIPMENT GROUNDS AND GROUNDING CONDUCTOR SHALL BE CONNECTED TO THESE GROUND LUGS. FOR GROUND CONNECTIONS TO ENCLOSURES, CASES AND FRAMES OF ELECTRICAL EQUIPMENT NOT SUPPLIED WITH GROUND LUGS THE CONTRACTOR SHALL DRILL REQUIRED HOLES FOR MOUNTING A BOLTED GROUND CONNECTOR. ALL BOLTED GROUND CONNECTORS SHALL BE BURNDY, OR EQUAL.
- BOND ALL NONCURRENT-CARRYING PARTS OF METAL EQUIPMENT TO GROUND SYSTEM.
- BUILDING STRUCTURAL STEEL SYSTEM SHALL BE BONDED TO ELECTRICAL GROUND SYSTEM.
- INSTALL GROUNDING ELECTRODE CONDUCTORS, LIGHTNING PROTECTION DOWN CONDUCTORS AND SEPARATE GROUND CONDUCTORS IN SCHEDULE 40 OR SCHEDULE 80 PVC CONDUIT OR EXPOSED WHERE ACCEPTABLE TO LOCAL CODES. WHERE GROUNDING ELECTRODE CONDUCTORS, LIGHTNING PROTECTION DOWN CONDUCTORS OR INDIVIDUAL GROUND CONDUCTORS ARE RUN IN PVC CONDUIT, DO NOT COMPLETELY ENIRCLE CONDUIT WITH FERROUS AND/OR MAGNETIC MATERIALS. USE NON-METALLIC REINFORCED FIBERGLASS STRUT SUPPORT. WHERE METAL CONDUIT CLAMPS ARE INSTALLED, USE NYLON BOLTS, NUTS, WASHERS AND SPACERS TO INTERRUPT A COMPLETE METALLIC PATH FROM ENCIRCLING THE CONDUIT. THIS IS REQUIRED TO AVOID GIRDLING OF GROUND CONDUCTORS. GIRDLING OF A GROUND CONDUCTOR IS THE RESULT OF PLACING THE CONDUCTOR IN A RING OF MAGNETIC MATERIAL. THIS RING COULD BE A METALLIC CONDUIT, U-BOLT OR STRUT SUPPORT PIPE CLAMP, OR OTHER SUPPORT HARDWARE. THE RESULT OF GIRDLING GROUND CONDUCTORS SIGNIFICANTLY INCREASES THE INDUCTIVE IMPEDANCE OF THE GROUND CONDUCTOR. INDUCTIVE AND CAPACITIVE IMPEDANCE IS A TYPE OF RESISTANCE THAT OPPOSES THE FLOW OF ALTERNATING CURRENT. ANY INCREASE IN THE IMPEDANCE OF A GROUND CONDUCTOR REDUCES ITS ABILITY TO EFFECTIVELY MITIGATE RADIO FREQUENCY NOISE IN THE GROUND SYSTEM. THE CONDITION WHERE A GROUND CONDUCTOR IS GIRDLED DURING A LIGHTNING STRIKE RESULTS IN PHENOMENA KNOWN AS SURGE IMPEDANCE LOADING. SURGE IMPEDANCE LOADING IS A RESULT OF VOLTAGE AND CURRENT REACHING 500,000 VOLTS AND 10,000 AMPS FOR A SHORT DURATION. GIRDLING FURTHER INCREASES THE IMPEDANCE AT LIGHTNING FREQUENCIES OF 100 KILOHERTZ TO 100 MEGAHERTZ. AT THESE POWER AND FREQUENCY LEVELS ANY INCREASE IN THE IMPEDANCE OF THE GROUND CONDUCTOR MUST BE CONTROLLED. DURING LIGHTNING DISCHARGE CONDITIONS A LOW INDUCTIVE IMPEDANCE PATH IS MORE IMPORTANT THAN A LOW DC RESISTANCE PATH.
- IF LOCAL CODES DICTATE THAT INDIVIDUAL GROUNDING CONDUCTORS MUST BE RUN IN METAL CONDUIT OR RACEWAY, THEN THE CONDUIT OR RACEWAY MUST BE BONDED AT EACH END OF THE RUN WITH A BONDING JUMPER SIZED EQUAL TO THE INDIVIDUAL GROUNDING CONDUCTOR OR AS REQUIRED BY 2011 NEC 250-102. NOTE THIS DOES NOT APPLY TO AC EQUIPMENT GROUNDING CONDUCTORS RUN WITH AC CIRCUITS.
- WHERE A CONFLICT IS DETERMINED WITH RESPECT TO GROUNDING REQUIREMENTS PER MANUFACTURER INSTALLATION INSTRUCTIONS, NEC, AND/OR THE CONTRACT DOCUMENTS, CONTACT THE RESIDENT ENGINEER OR PROJECT ENGINEER FOR FURTHER DIRECTIONS.
- GROUND RODS SHALL BE MANUFACTURED IN THE UNITED STATES OF AMERICA TO COMPLY WITH THE AIRPORT IMPROVEMENT PROGRAM BUY AMERICAN REQUIREMENTS. STEEL USED TO MANUFACTURER GROUND RODS SHALL BE 100 PERCENT DOMESTIC STEEL.

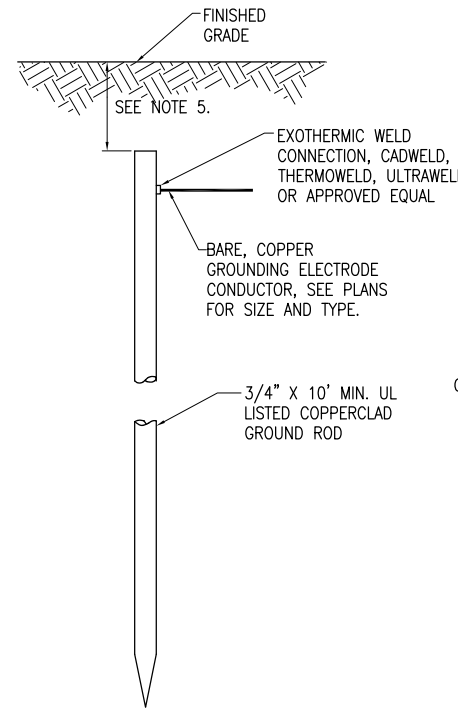

10 FT. GROUND ROD

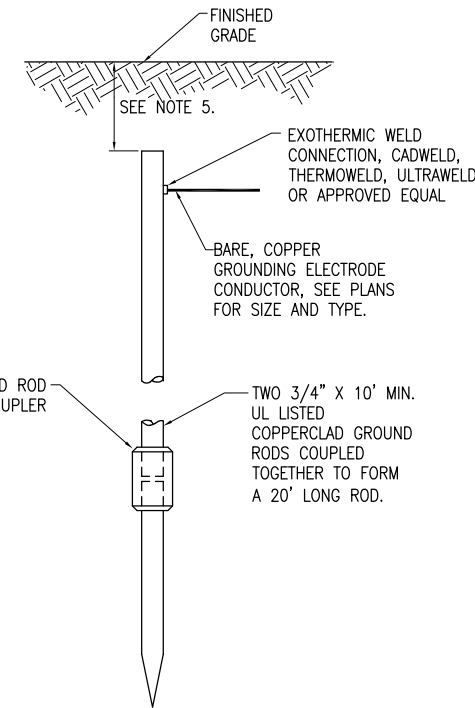

20 FT. GROUND ROD

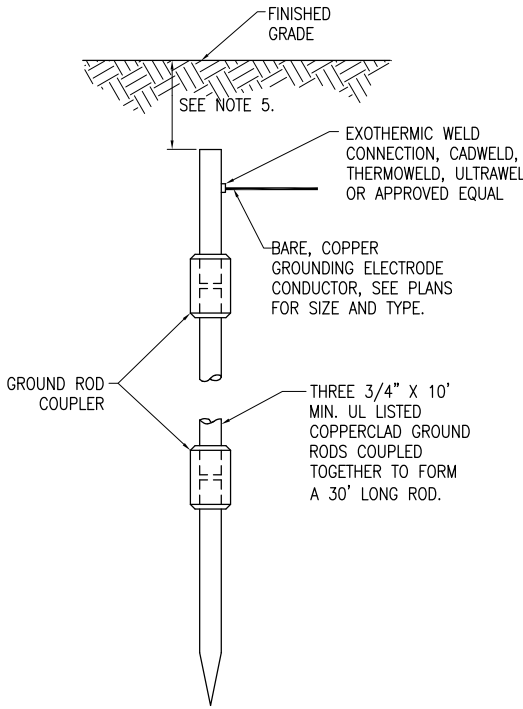

30 FT. GROUND ROD

GROUND RODS
(NOT TO SCALE)

NOTES

- TYPE AND MINIMUM NUMBER OF GROUND RODS SHALL BE AS SPECIFIED ON THE PLAN.
- THE RESISTANCE TO GROUND OF THE GROUNDING SYSTEM SHALL NOT EXCEED 25 OHMS.
- COST OF GROUND RODS IS INCIDENTAL TO THE ASSOCIATED ITEMS REQUIRING GROUNDING UNLESS OTHERWISE SPECIFIED. GROUND RODS FOR VAULT WILL BE CONSIDERED INCIDENTAL TO ITEM AR109200.
- GROUND RODS SHALL BE SPACED AS DETAILED ON THE PLANS AND SHALL NOT BE SPACED LESS THAN ONE ROD LENGTH APART.
- TOP OF GROUND RODS SHALL BE 12" MINIMUM BELOW GRADE UNLESS DETAILED OTHERWISE HEREIN. TOP OF GROUND RODS FOR VAULT SHALL BE 30" MIN. BELOW GRADE. GROUND RING CONDUCTORS SHALL BE 40" MINIMUM BELOW GRADE TO BE BELOW FROST LINE FOR MARSHALL COUNTY, ILLINOIS.

JAN 11, 2013 1:21 PM HARR01115
 p:\s\spc\306\hanson\Documents\09a\031\09a0031\09a0031.dwg\Airport_Sheet[E-004-NOTE]

REVISION	DATE																						
<p>MARSHALL COUNTY AIRPORT LACON, ILLINOIS</p>																							
<p>IL PROJ.: C75-4218 BLOCK GRANT: 3-17-0059-B14</p>																							
<p>Hanson Project No. 09A0031</p>	<p>Filename E-004-NOTE.dwg</p>	<table border="1" style="width: 100%; border-collapse: collapse;"> <tr> <td style="width: 10%;">Scale</td> <td style="width: 10%;">NOT TO SCALE</td> <td style="width: 10%;">Date</td> <td style="width: 10%;">01/11/13</td> <td style="width: 10%;">LAYOUT</td> <td style="width: 10%;">KNL</td> <td style="width: 10%;">08/16/12</td> </tr> <tr> <td></td> <td></td> <td></td> <td></td> <td>DRAWN</td> <td>BAK</td> <td>08/16/12</td> </tr> <tr> <td></td> <td></td> <td></td> <td></td> <td>REVIEWED</td> <td>BSS</td> <td>01/11/13</td> </tr> </table>	Scale	NOT TO SCALE	Date	01/11/13	LAYOUT	KNL	08/16/12					DRAWN	BAK	08/16/12					REVIEWED	BSS	01/11/13
Scale	NOT TO SCALE	Date	01/11/13	LAYOUT	KNL	08/16/12																	
				DRAWN	BAK	08/16/12																	
				REVIEWED	BSS	01/11/13																	
<p>© Copyright Hanson Professional Services Inc. 2012 Hanson Professional Services Inc. 1625 S.W. 11th Street Springfield, Illinois 62703-2886</p>																							
<p>CONSTRUCT A 2,065' X 35' PARTIAL PARALLEL TAXIWAY TO RUNWAY 13/31</p>																							
<p>GROUNDING NOTES</p>																							
<p>79 79 of 79 sheets</p>																							