

ROUTE	SECTION	COUNTY	TOTAL SHEETS	SHEET NUMBER
VARIOUS	2006-018BP	VARIOUS	27	3

Contract 60B43

GENERAL NOTES FOR PAINT

CLEANING AND PAINTING OF THE EXISTING STRUCTURAL STEEL SHALL BE AS SPECIFIED IN THE SPECIAL PROVISION FOR "CLEANING AND PAINTING EXISTING STEEL STRUCTURES".

LOCATIONS 1, 2 AND 3 CONTAIN LEAD PAINT. A MINIMUM OF FOUR (4) [AT LOCATION 1] AND TWO (2) [AT LOCATIONS 2 & 3] AIR MONITORS WILL BE REQUIRED TO MONITOR ABRASIVE BLASTING OPERATIONS PER LOCATION, SEE SPECIAL PROVISIONS FOR CONTAINMENT AND DISPOSAL OF LEAD PAINT CLEANING RESIDUE. LOCATIONS 4, 5 & 6, DO NOT CONTAIN LEAD PAINT. CONTAINMENT SHALL BE IN ACCORDANCE WITH THE SPECIAL PROVISION "CONTAINMENT AND DISPOSAL OF NON-LEAD PAINT CLEANING RESIDUES".

THE SSPC-QP1 AND SSPC-QP2 PAINTING CONTRACTOR CERTIFICATIONS WILL NOT BE REQUIRED FOR THESE BRIDGES.

THE AREAS DESIGNATED TO BE CLEANED PER NEAR WHITE BLAST CLEANING SSPC-SP10 SHALL BE PAINTED ACCORDING TO THE REQUIREMENTS OF PAINT SYSTEM 1 - OZ/E/U. THE COLOR OF THE FINAL FINISH COAT FOR ALL INTERIOR STEEL SURFACES SHALL BE GRAY, MUNSELL NO 5B 7/1. THE COLOR OF THE FINAL FINISH COAT FOR THE EXTERIOR AND BOTTOM FLANGE OF THE FASCIA BEAMS SHALL BE REDDISH BROWN, MUNSELL NO 2.5YR 3/4.

ALL ITEMS (SUCH AS, BUT NOT LIMITED TO; CONDUITS, BRACKETS AND DECK DRAINS) ATTACHED TO THE OUTSIDE OF THE FASCIA BEAMS SHOULD BE CLEANED AND PAINTED.

ALL BEAMS, BEARINGS AND OTHER STRUCTURAL STEEL WITHIN FIVE (5) FT., TEN (10) FT. AT LOCATION 4 (SN 056-0059), (MEASURED ALONG THE BEAM) OF EITHER SIDE OF THE DECK JOINTS INCLUDING JOINTS AT PIN & LINKS ON LOCATION 2 (SN 023-0106), SHALL BE CLEANED PER NEAR WHITE BLAST CLEANING SSPC-SP10. THE EXTERIOR SURFACES AND TOP AND BOTTOM OF THE BOTTOM FLANGE OF THE FASCIA BEAMS (SEE FIGURE 1) SHALL ALSO BE CLEANED PER NEAR WHITE BLAST CLEANING SSPC-SP10.

FASCIA BEAM PAINTING DETAIL

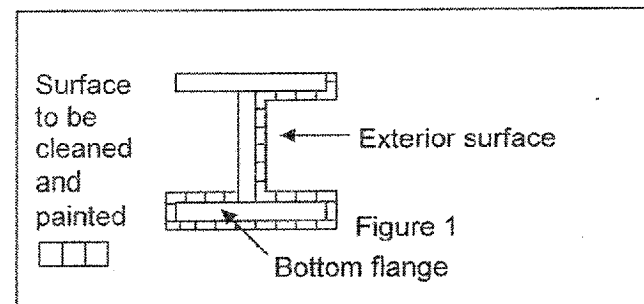

ILLINOIS DEPARTMENT OF TRANSPORTATION

GENERAL PAINT NOTES