

STATE OF ILLINOIS  
DEPARTMENT OF TRANSPORTATION

ROUTE NO.	SECTION	COUNTY	TOTAL SHEETS	SHEET NO.	SHEET NO.
F.A.P. 545	114T-1	CARROLL	118	29	07 SHEETS
FED. ROAD DIST. NO. 2	BILLINGS	FED. AID PROJECT-			

Contract # 64C31

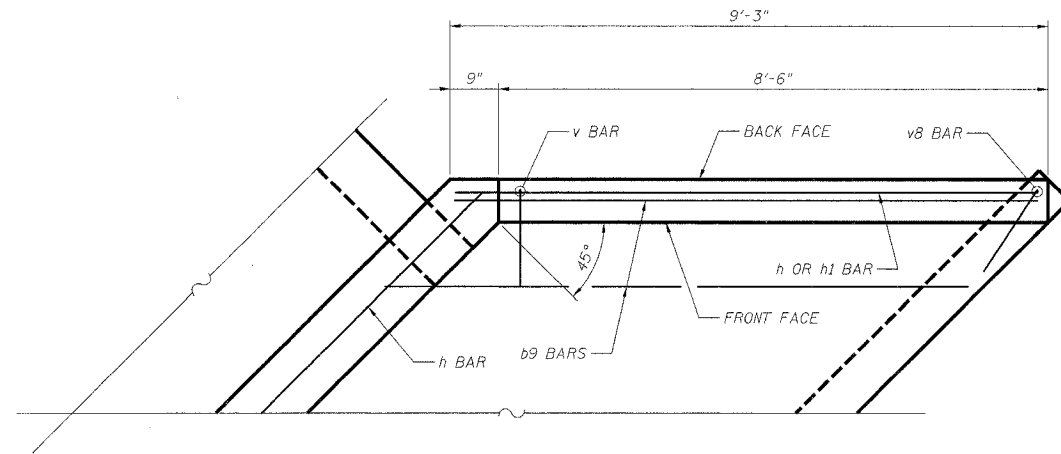

**WING PLAN**  
SIMILAR ALL WINGS (4 TOTAL)

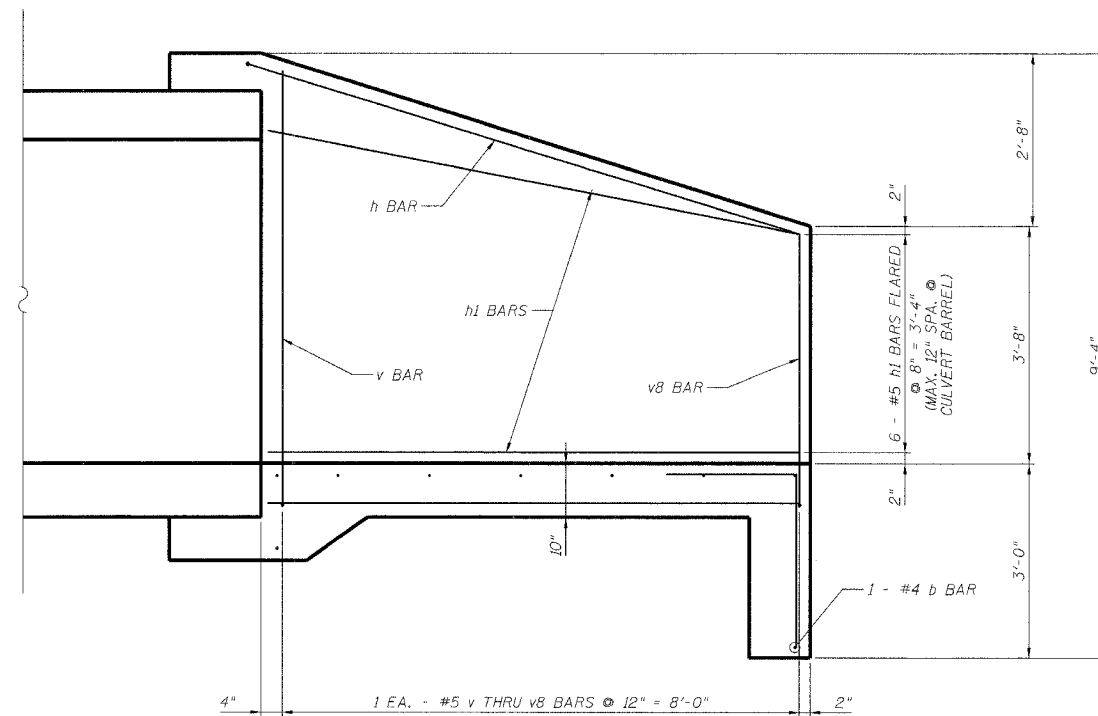

**WING ELEVATION**  
SIMILAR ALL WINGS (4 TOTAL)

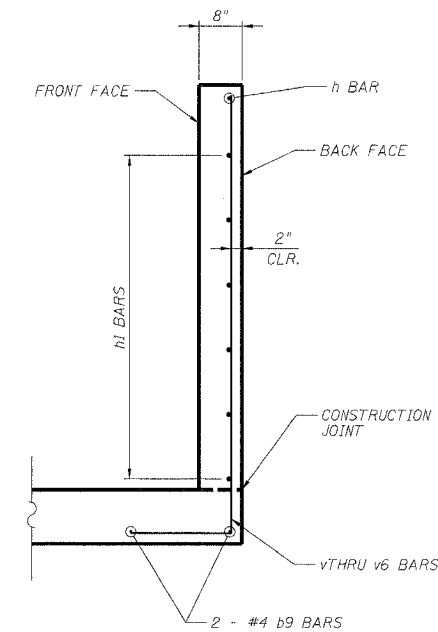

**WING TYPICAL SECTION**  
SIMILAR ALL WINGS (4 TOTAL)

DESIGNED -	ASP
CHECKED -	WSP
DRAWN -	BGC
CHECKED -	ASP

EXAMINED	200
PASSED	ENGINEER OF BRIDGE DESIGN
	ENGINEER OF BRIDGES AND STRUCTURES

**WINGS A THRU D**  
**F.A.P. 545 (IL. RTE. 72)**  
**SECTION 114T-1**  
**CARROLL COUNTY**  
**STATION 244+43.50**  
**STRUCTURE NO. 008-1090**