

ROUTE NO.	SECTION	COUNTY	SHEETS	SHEET NO.
FAS 55	*	WINNEBAGO	16	52
13 SHEETS				

(102 BR-1, 102 BR-2, 102 BR-3)D
Contract # 64C93

Note:
Place strands symmetrically about \bar{C} of beam.

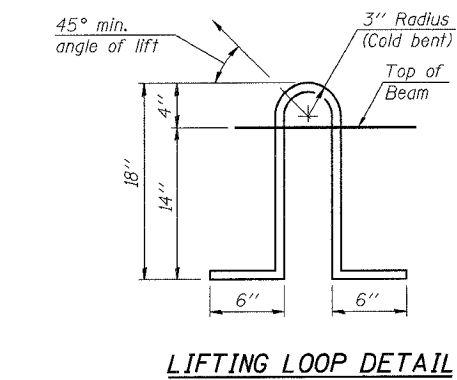
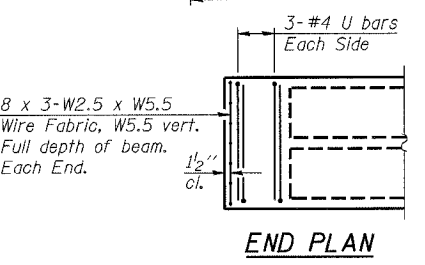
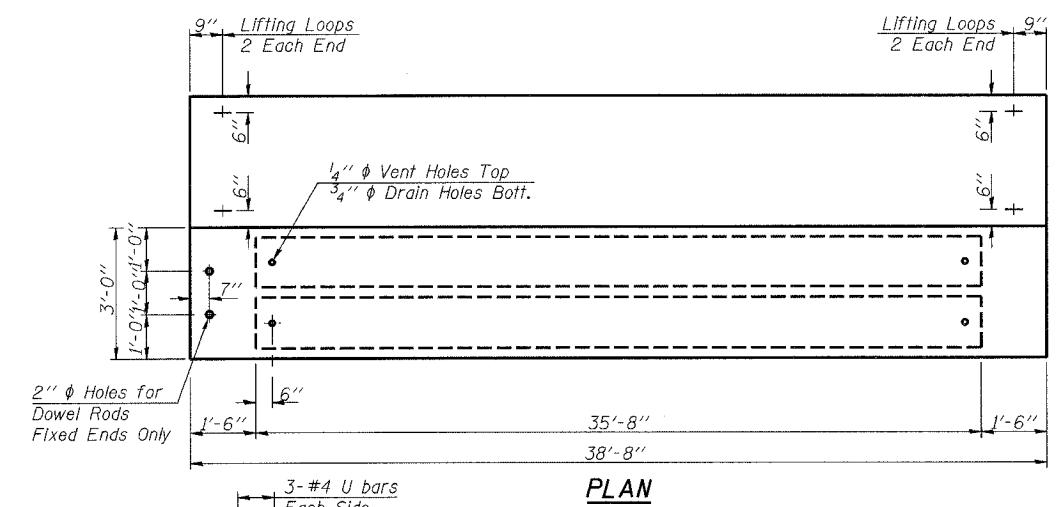
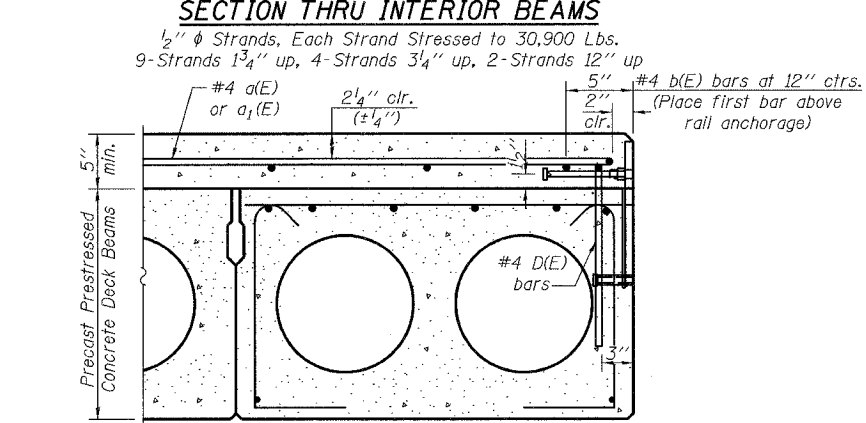
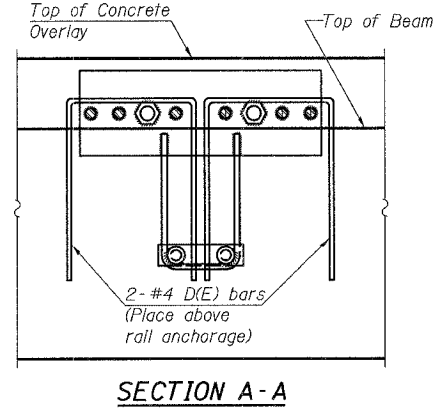
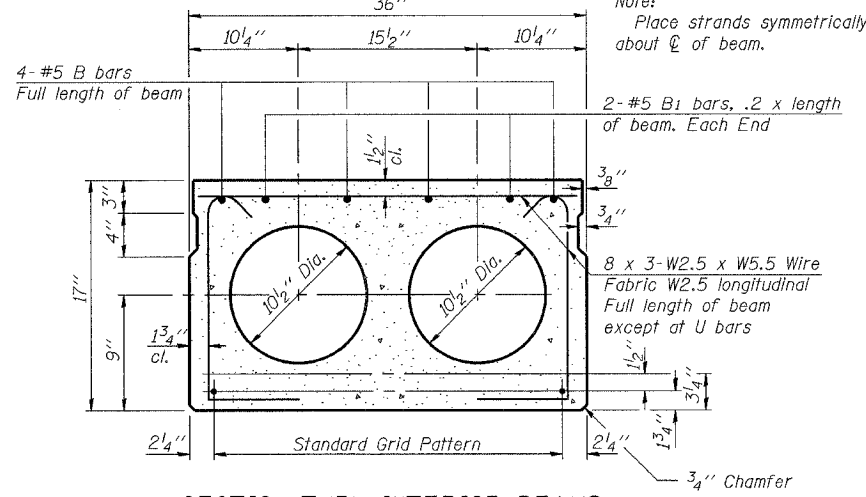
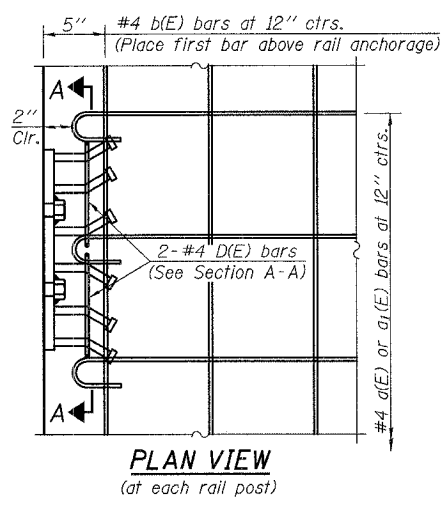
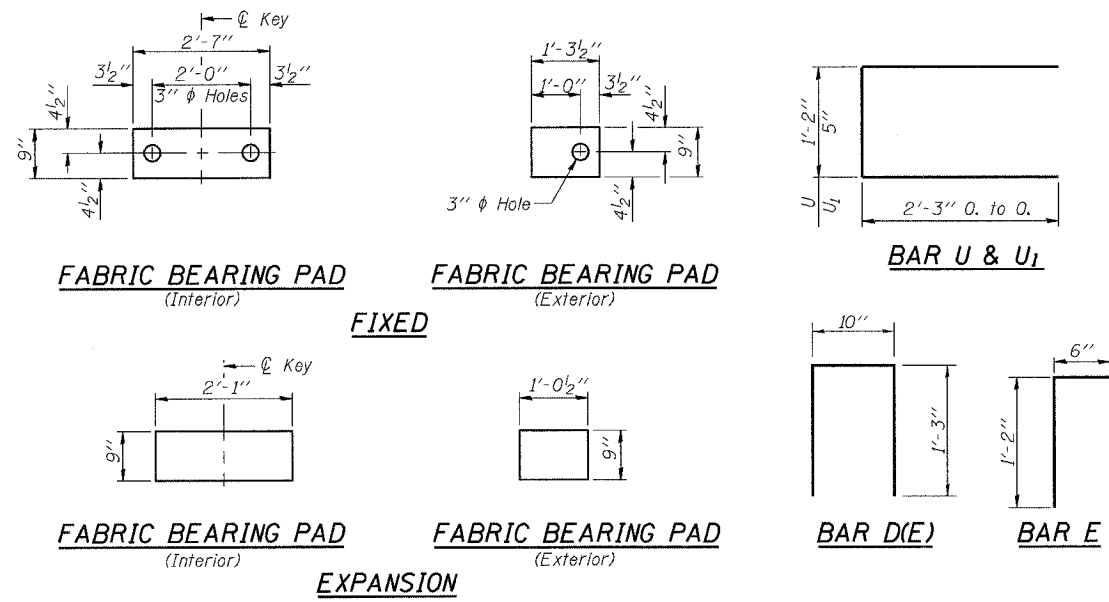

NOTES

Prestressing steel shall be uncoated high strength, low relaxation 7-wire strand, Grade 270. The nominal diameter shall be 1/2" and the nominal cross-sectional area shall be 0.153 sq. in. Lifting loops shall be 2-1/2" ϕ -270 ksi strands, as shown. Reinforcement bars shall conform to the requirements of ASTM A 706 Gr 60 (IL Modified). See Special Provisions. The bearing seat surfaces shall be adjusted by shimming to assure firm and even bearing. Two 1/2" fabric adjusting shims of the dimensions of the Exterior Bearing Pad shall be provided for each bearing. Keyway surfaces shall be cleaned to remove form oil or other bond breaking material prior to shipment of the beams. Cleaning shall be done by sandblasting the keyway areas between top of the beam and the bottom edge of the key. Corrosion Inhibitor, as covered in section 1020.05(b)(12) and 1021.06 of the Standard Specification, shall be used in the concrete for precast prestressed concrete deck beams. Required Release Strength, f'cl, shall be 4000 p.s.i. Bridge rail inserts shall be cast in precast beams. See Sheet 4 of 13 for location of rail inserts. The rail anchorage shall be cast with the beam and the wearing surface shall be cast in the field. Formwork necessary for the wearing surface may be secured utilizing the bottom rail anchorage inserts and/or additional inserts cast into the beam. Drilling into the beam will not be permitted.

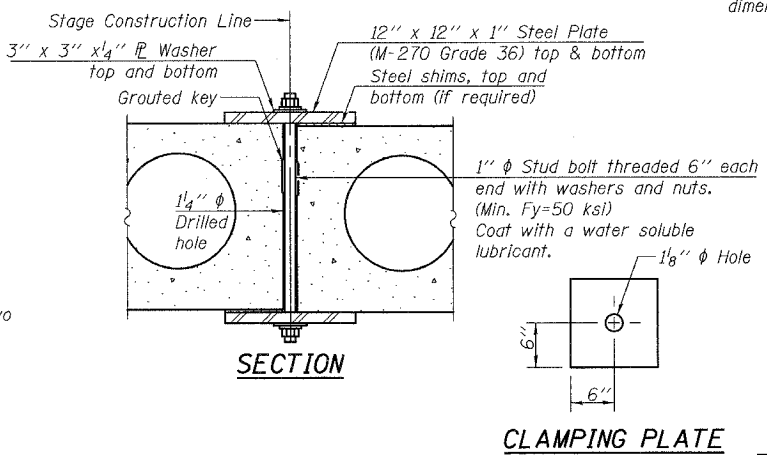

SHEAR KEY CLAMPING DETAILS AT STAGE CONST. JT.

Refer to Article 504.06(d) of the Standard Specifications. Cost included with Precast Prestressed Concrete Deck Beams (17" Depth). See Stage Construction Details for traffic lanes, Sheet 3 of 13.

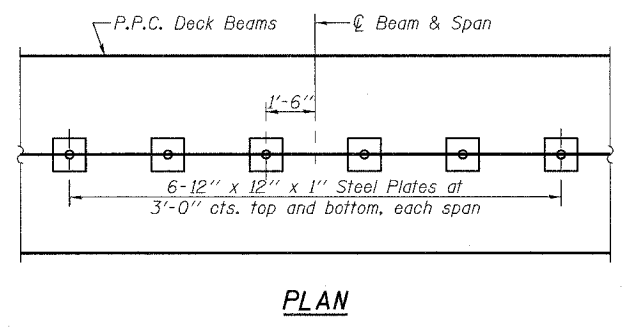

ILLINOIS DEPARTMENT OF TRANSPORTATION
SUPERSTRUCTURE DETAILS II
IL-70 OVER TRIBUTARY TO PECATONICA RIVER
FAS RTE 55
SECTION (102 BR-1, 102 BR-2, 102 BR-3)D
WINNEBAGO COUNTY
STATION 302+76.80
STRUCTURE NO. 101-0146
DATE: 12/15/2006
DRAWN BY LCM
CHECKED BY BLB

rjngroup
 Excellence through Ownership
 200 West Front Street
 Wheaton, IL 60187