

F.A.P. RTE.	SECTION	COUNTY	TOTAL SHEETS	SHEET NO.
623	*	LASALLE	126	103
STA.		TO STA.		
FED. ROAD DIST. NO.	ILLINOIS	FED. AID PROJECT		
*(34)R,DM&X-1)RS&BR				

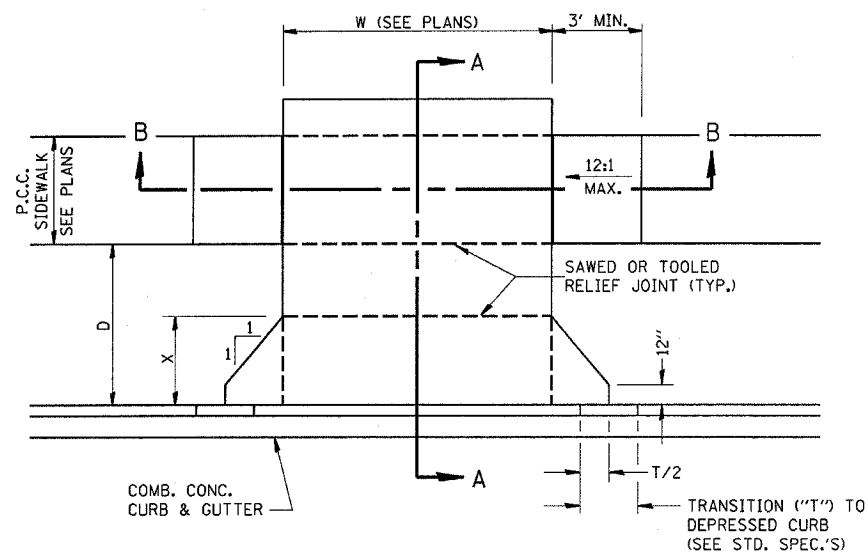

CASE I (D ≥ X)

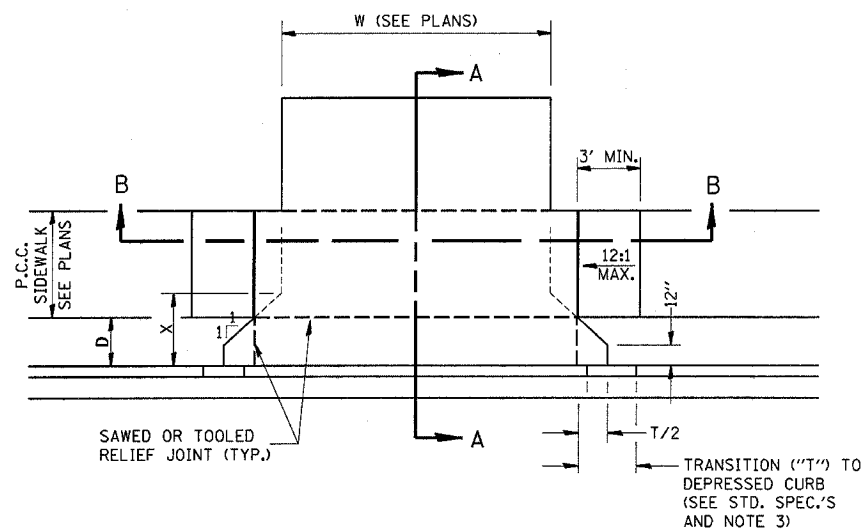

CASE I (D < X)

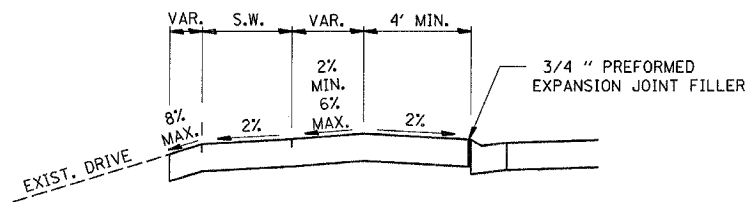

DEPRESSED ENTRANCE \*  
SECTION A-A

\*(SEE X-SECTIONS FOR ENTRANCE PROFILE.)

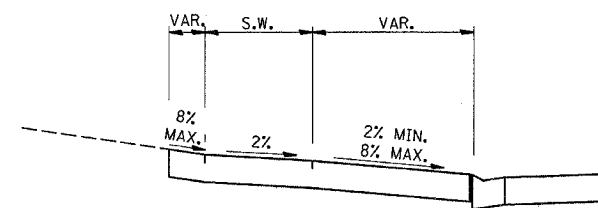

ELEVATED ENTRANCE \*  
SECTION A-A

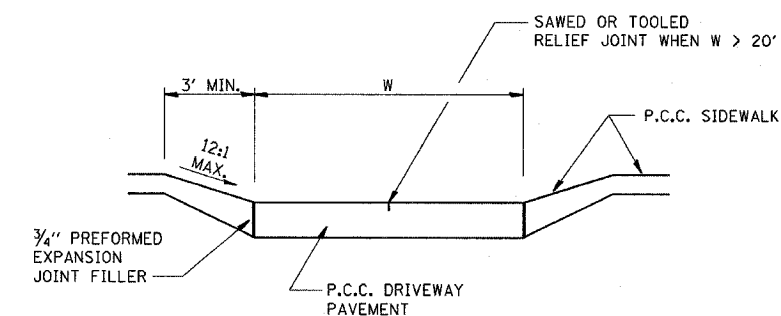

SECTION B-B

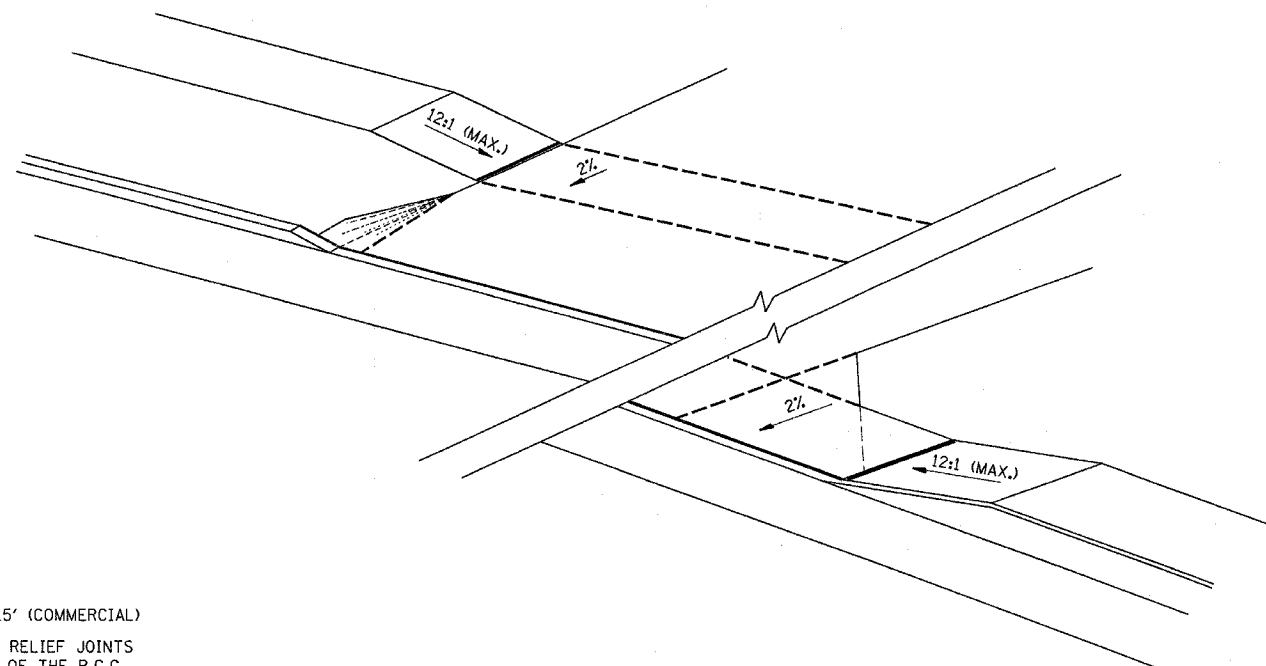

GENERAL NOTES:

1. X = 7' (NON-COMMERCIAL) X = 15' (COMMERCIAL)
2. COST OF EXPANSION JOINTS AND RELIEF JOINTS SHALL BE INCLUDED IN THE COST OF THE P.C.C. DRIVEWAY PAVEMENT.
3. AS THE DIMENSION "D" APPROACHES ZERO, THE TRANSITION TO DEPRESSED CURB SHALL BE NO STEEPER THAN 12:1

PCC URBAN ENTRANCES

REVISIONS	
NAME	DATE

ILLINOIS DEPARTMENT OF TRANSPORTATION

DETAILS

SCALE: VERT. HORIZ.  
DATE

DRAWN BY  
CHECKED BY