

ROUTE NO.	SECTION	COUNTY	SHEET	DATE	SHEET NO. 26
FAI 72	*	SANGAMON	559	279	44 SHEETS
FED. ROAD DIST. NO. 7	ILLINOIS	FED. AID PROJECT			

*84-9-4(A), H.B.K., BY-1 Contract No 72541

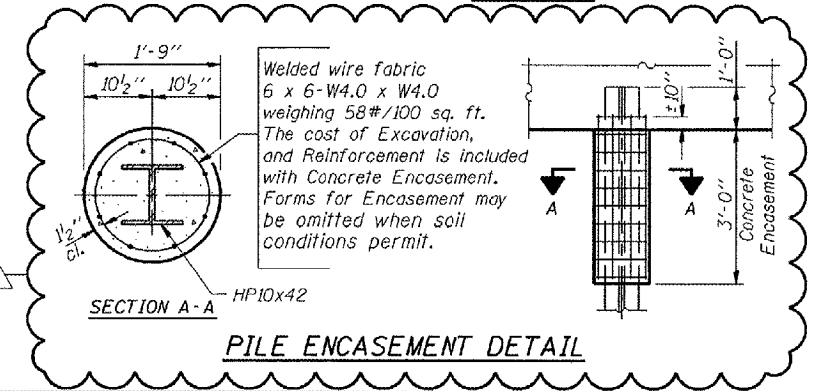
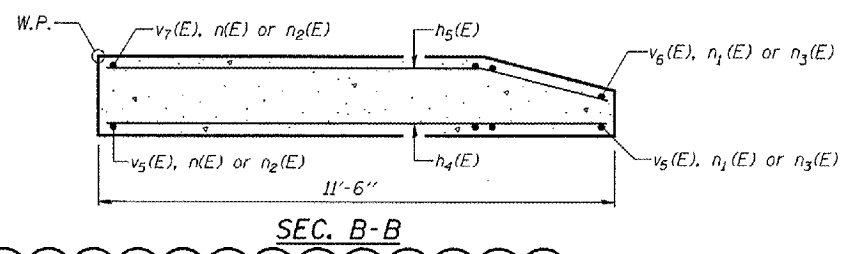
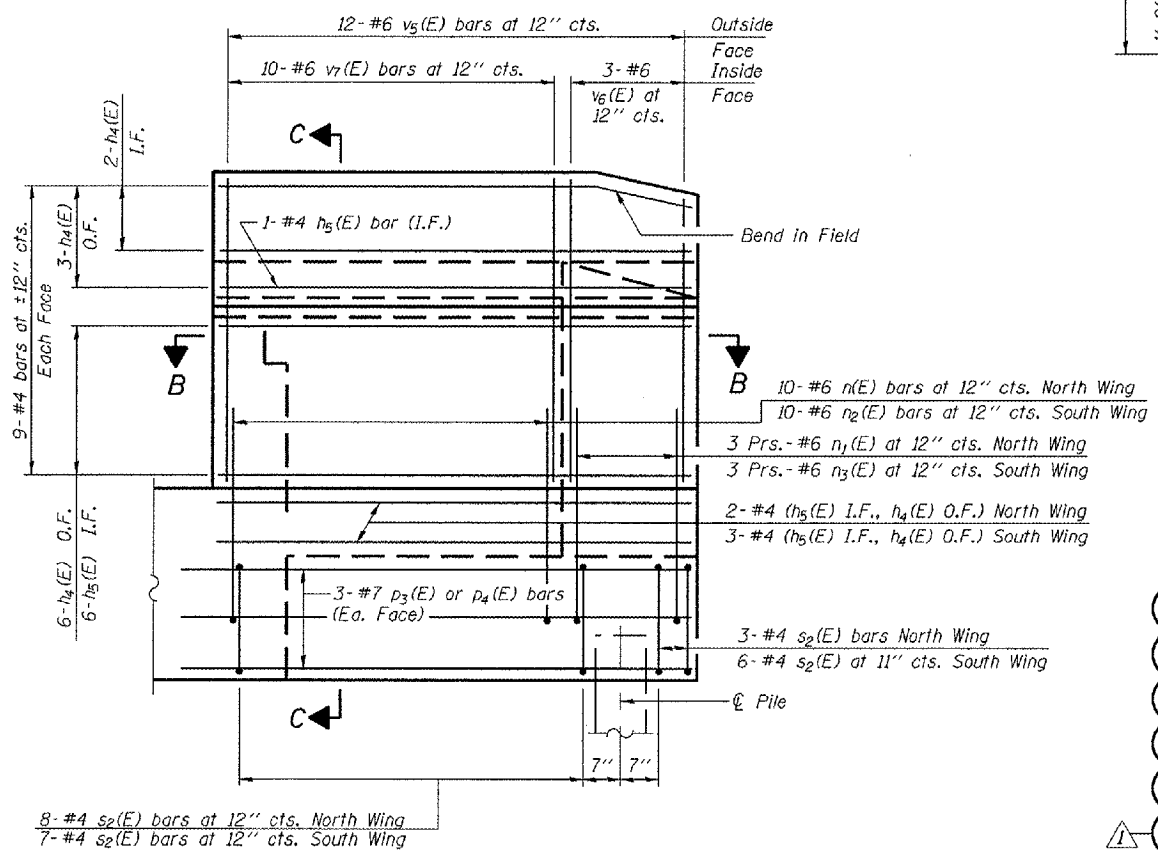
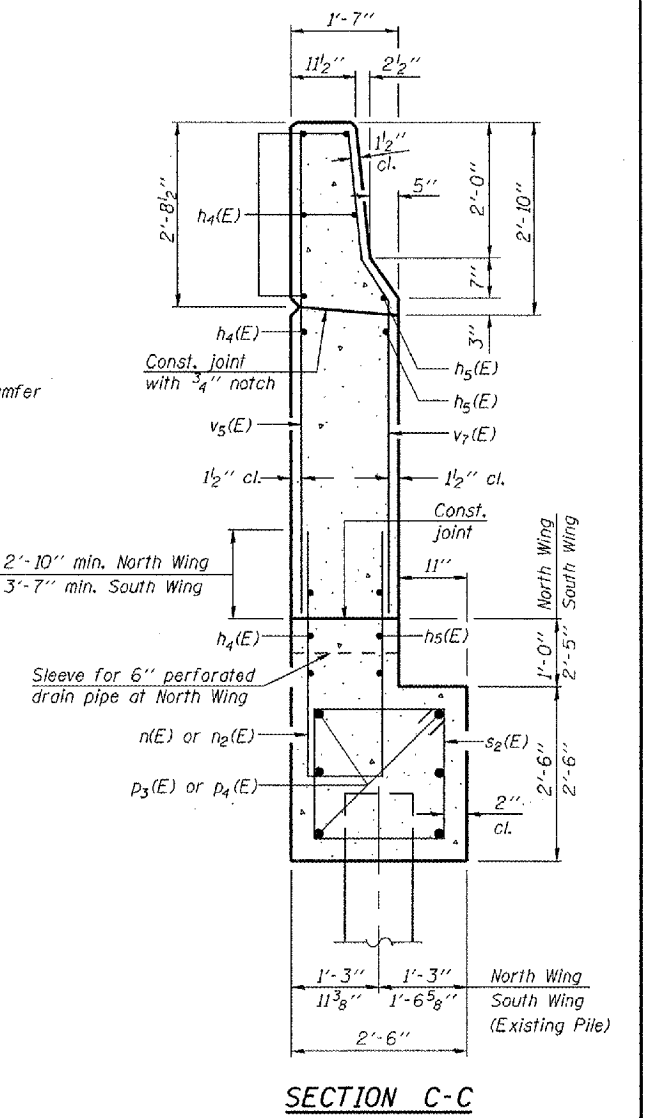
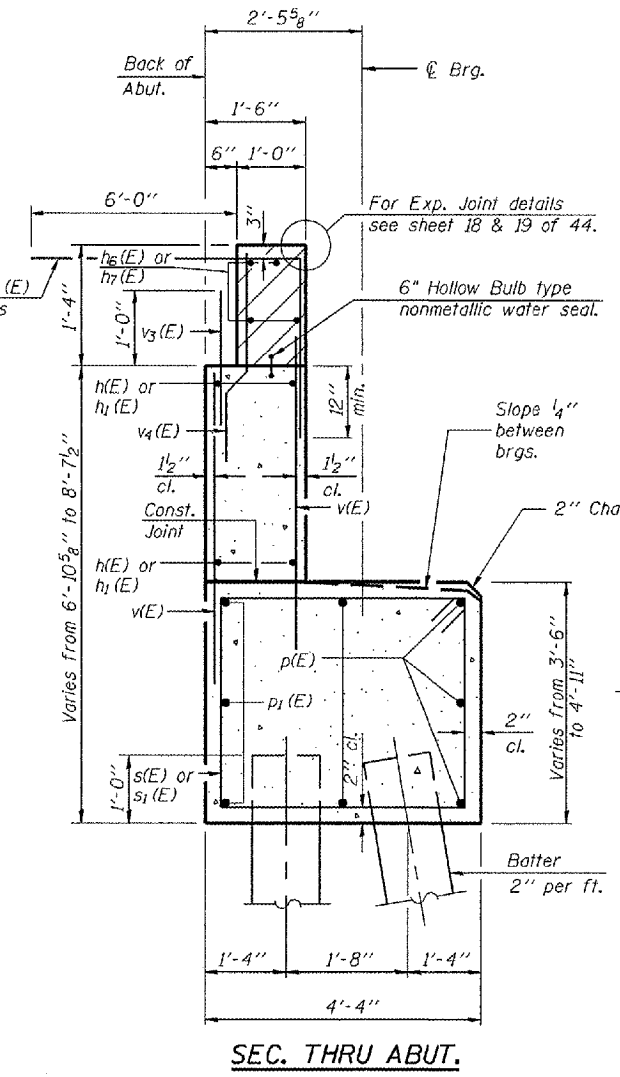
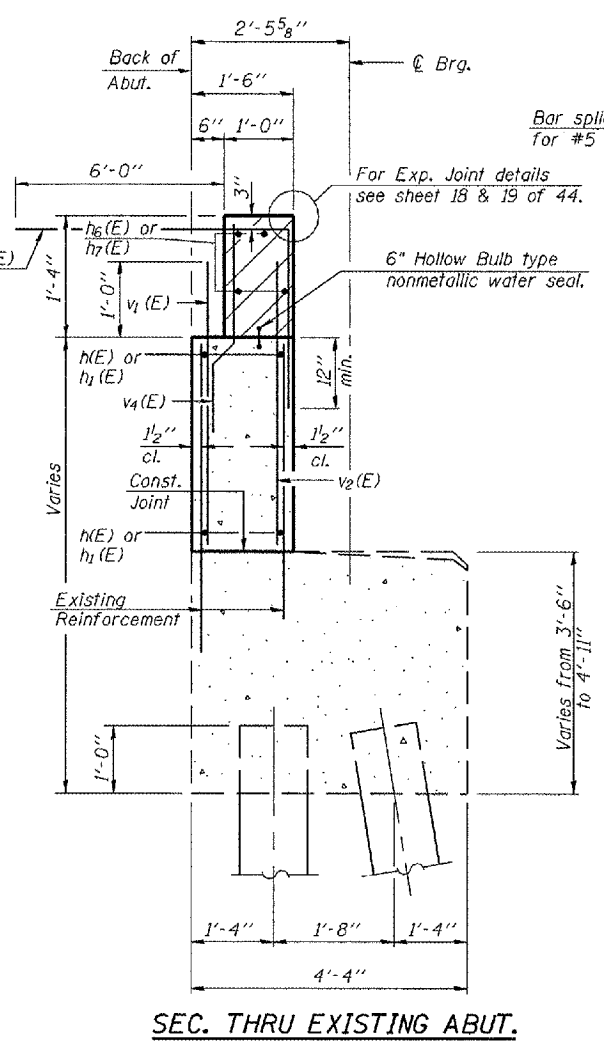
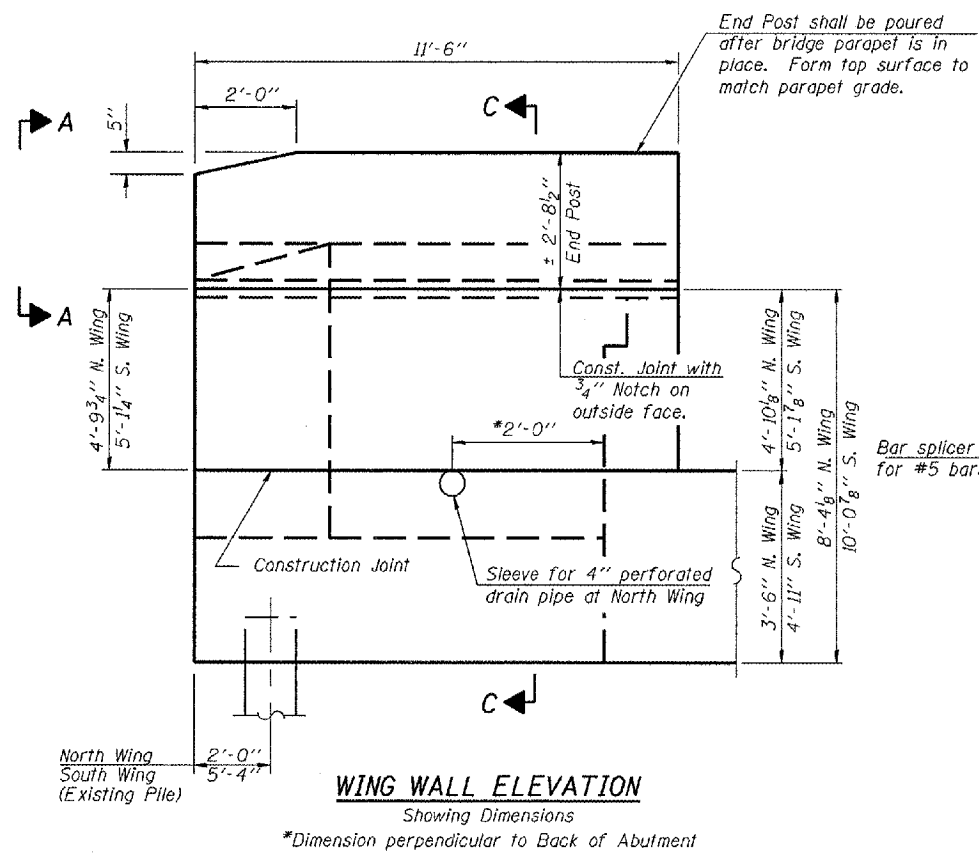

MIN. BAR LAPS

#4 Bar	1'-8"
#5 Bar	2'-2"
#6 Bar	2'-7"
#7 Bar	3'-5"

Notes: Hatched area to be poured after superstructure forms have been removed. Quantity of concrete included with Concrete Superstructure. Space reinforcement in cap to miss anchor bolts. Pour steps monolithically with cap. Reinforcement bars designated (E) shall be epoxy coated. Quantity of concrete in end post included with Concrete Superstructure on sheet 13 of 44. Cost for sleeve shall be included with Concrete Structures.

Corporate License Number 184-001-084

WESTBOUND-WEST ABUTMENT DETAILS
F.A.I. 72 OVER UNION PACIFIC RAILROAD
SECTION (84-9-4), H.B.K., BY-1
SANGAMON COUNTY
STATION 608+51.98
STR NO. 084-0074 EB - 084-0075 WB

Copyright Hanson Professional Services Inc. SMS_YEAR8

9652002B

01/12/06

HANSON

LAYOUT	MM	06/21/03
DRAWN	DAP	07/17/03
REVIEWED	JWW	10/27/03