

ROUTE NO.	SECTION	COUNTY	POST MILES	SHEET	SHEET NO. 16 21 SHEETS
FAI 72 FAU 8071	*	SANGAMON	559	335	
FED. ROAD DIST. NO. 7		ILL. PROJ. NO.		FED. AID PROJECT NO.	

84-9-41A, H.B.K., BY, BY-1 Contract No 72541

Notes: Hatched area to be poured after superstructure forms have been removed. Quantity of concrete included with Concrete Superstructure. Space reinforcement in cap to miss anchor bolts. Pour steps monolithically with cap. Reinforcement bars designated (E) shall be epoxy coated. Quantity of concrete in end post included with Concrete Superstructure on sheet 08 of 21. Conduit is embedded in the North Wing. For details, see Conduit Details sheet in the Roadway Plans.

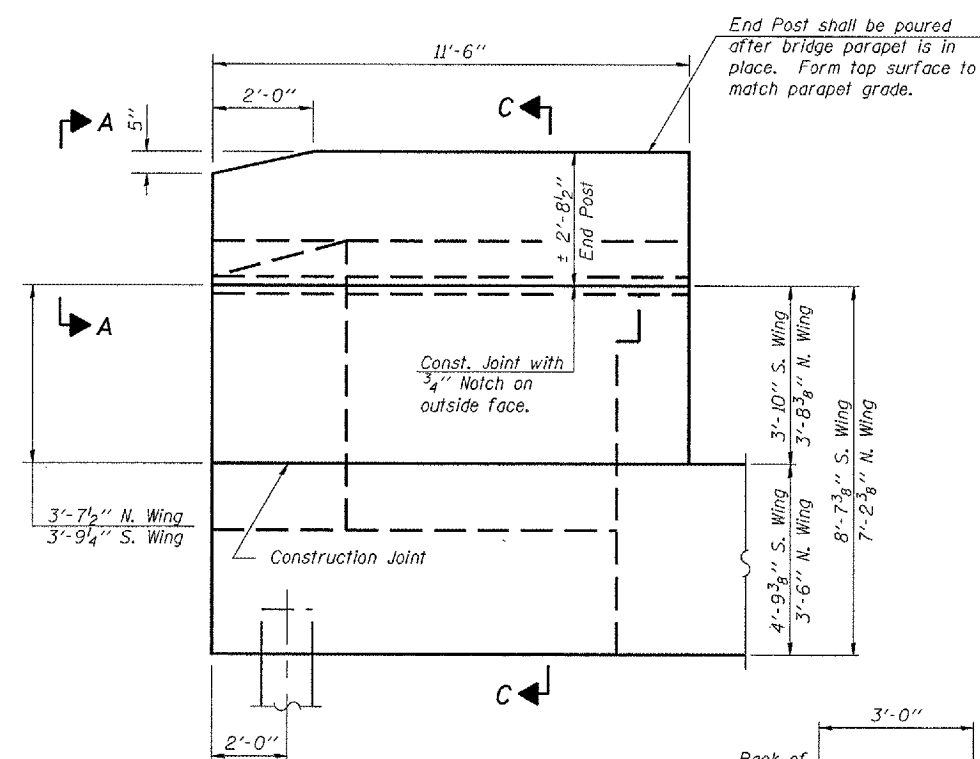

**WING WALL ELEVATION**  
Showing Dimensions

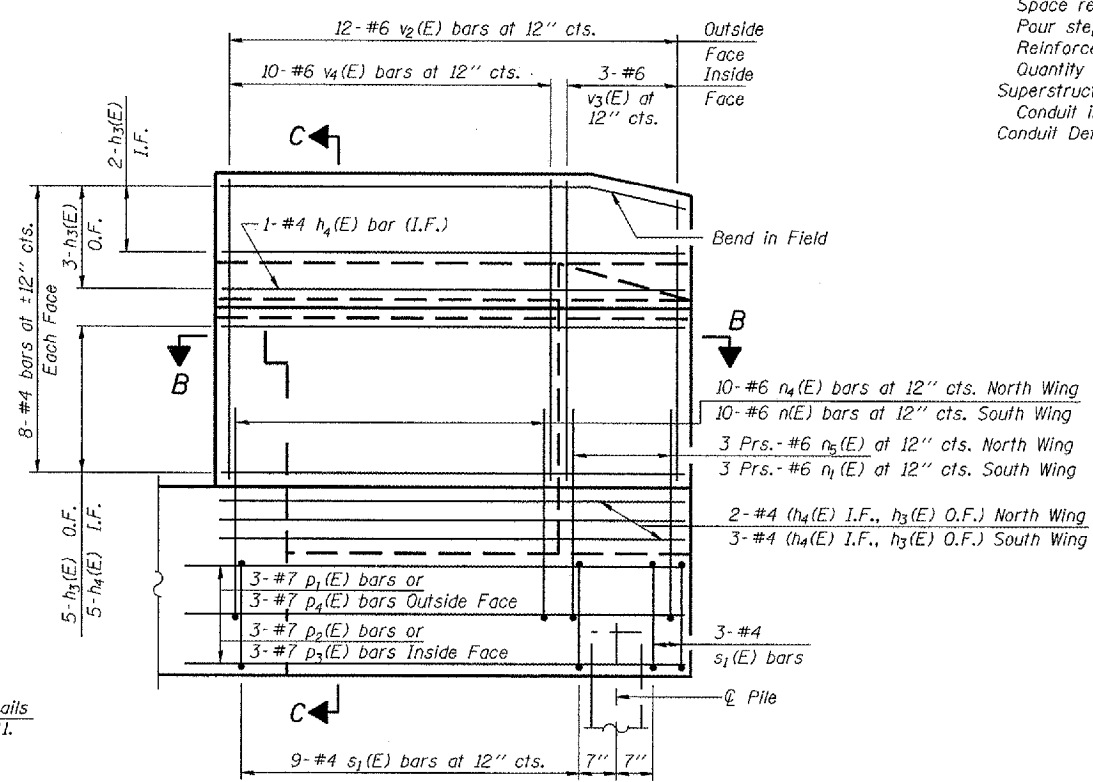

**WING WALL ELEVATION**  
Showing Reinforcement

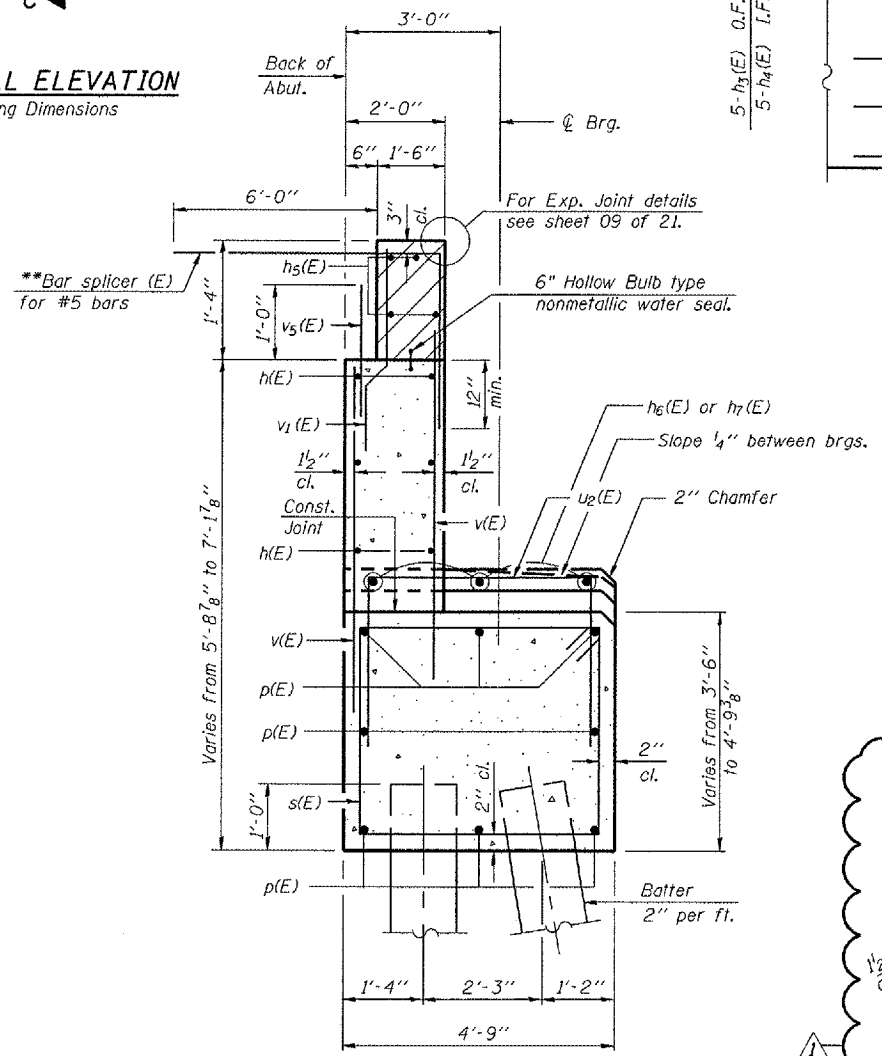

**SEC. THRU ABUT.**  
\*\*Alternate with #4 v(E) bars  
Place parallel to the beams

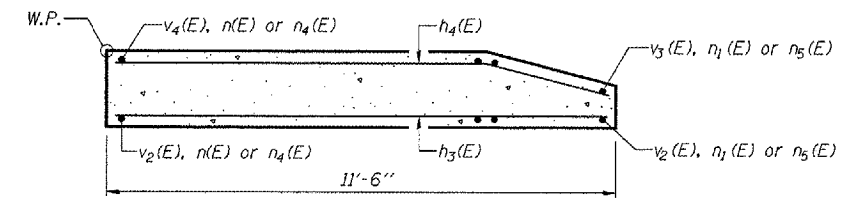

**SEC. B-B**

**MIN. BAR LAPS**

- #4 Bar - 1'-8"
- #5 Bar - 2'-2"
- #6 Bar - 2'-7"
- #7 Bar - 3'-5"

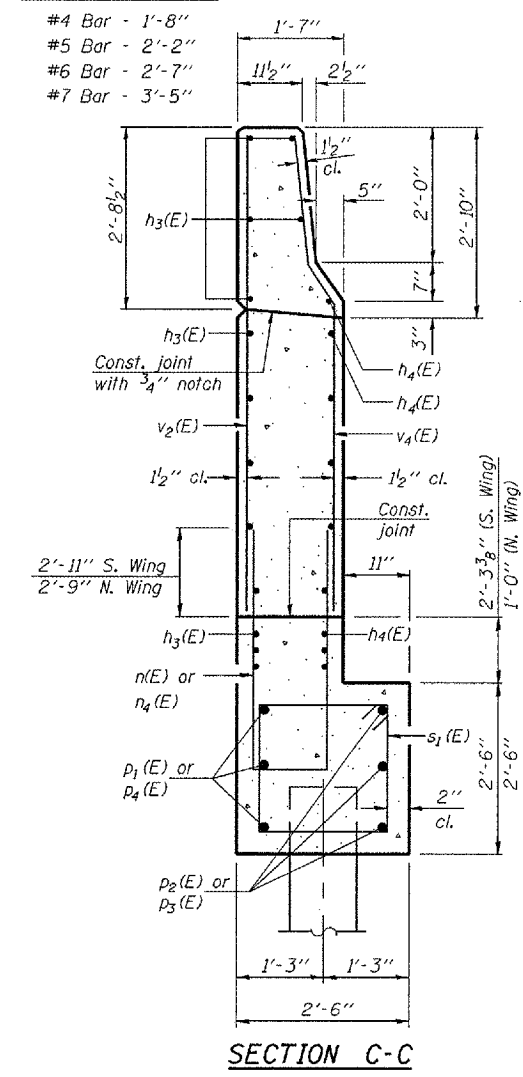

**SECTION C-C**

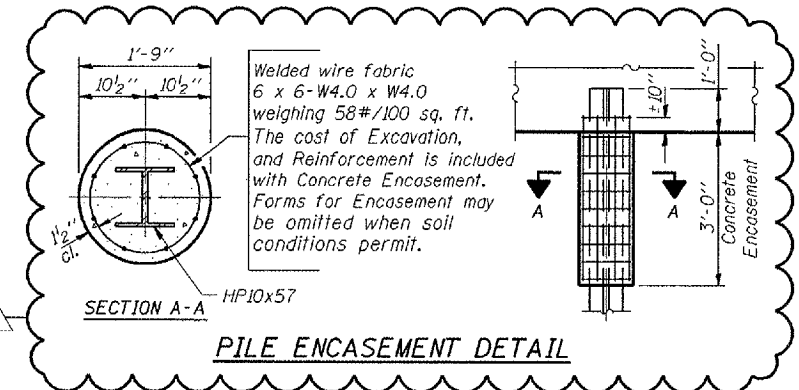

**PILE ENCASEMENT DETAIL**

Corporate License Number 184-001-084  
**EAST ABUTMENT DETAILS**  
 I-72/MACARTHUR BLVD. RAMP C OVER UPRR  
 SECTION (84-9-4)A, H.B.K., BY, BY-1  
 SANGAMON COUNTY  
 STATION 46+01.97  
 STRUCTURE NUMBER 084-0516

© Copyright Hanson Professional Services Inc. SMS\_YEAR# 96S2002B  
**HANSON**  
 DATE: 11/16/05

LAYOUT	MMW	06/27/03
DRAWN	DAF	01/04/05
REVIEWED	JWN	02/24/05