

WING WALL ELEVATION
Showing Dimensions

*Dimension perpendicular to Back of Abutment

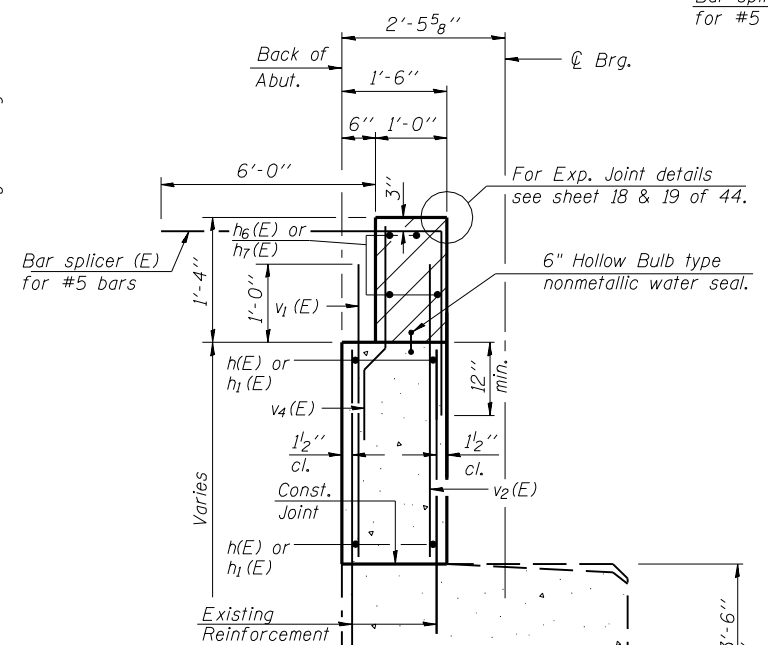

SEC. THRU ABUT.

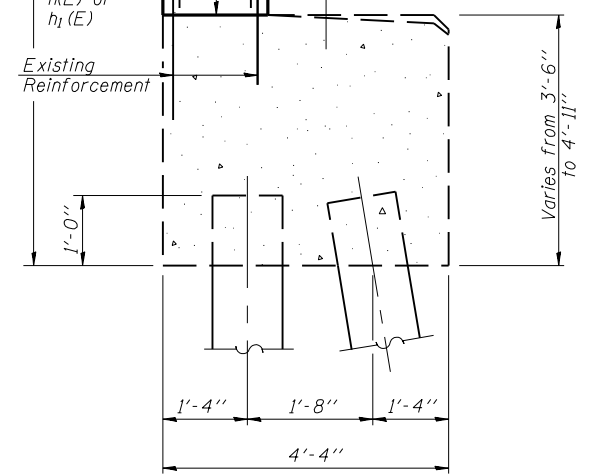

SEC. THRU EXISTING ABUT.

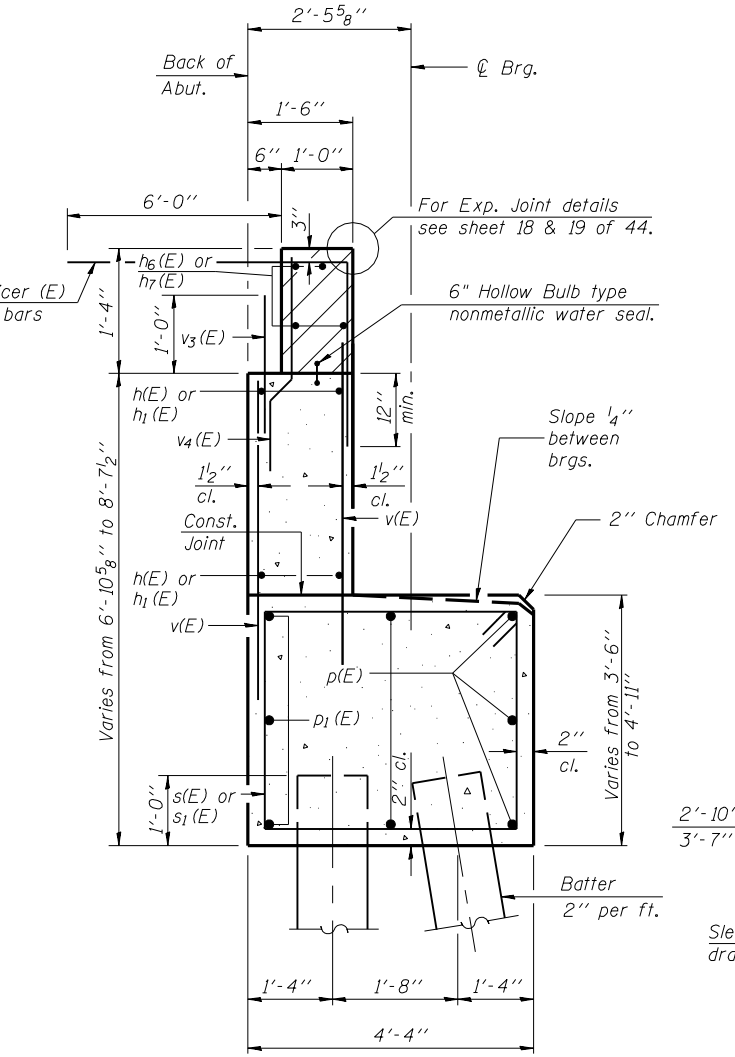

SEC. B-B

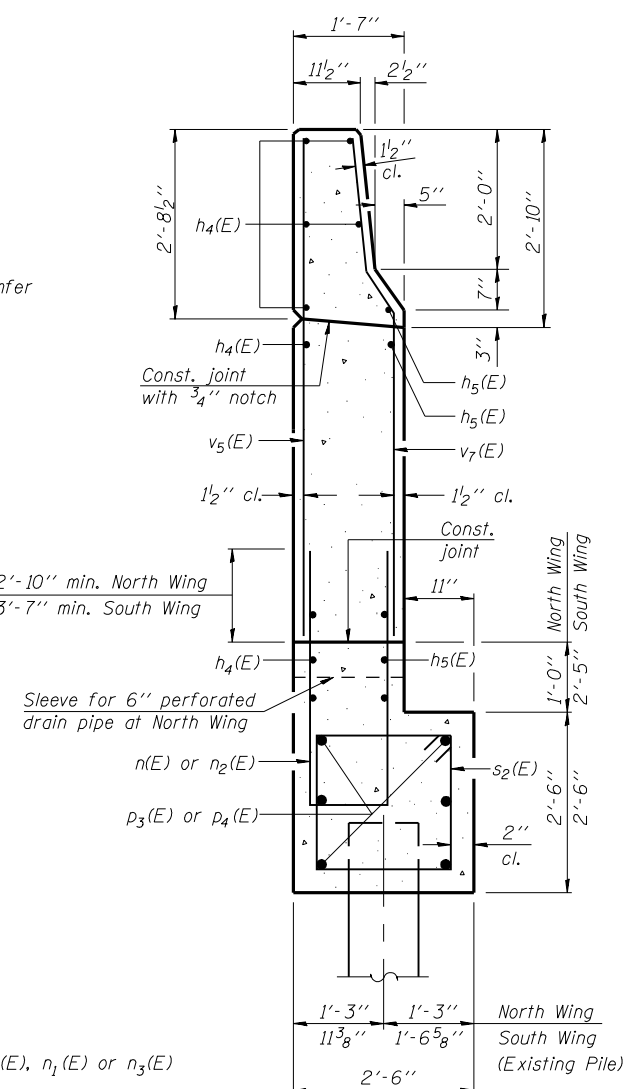

SECTION C-C

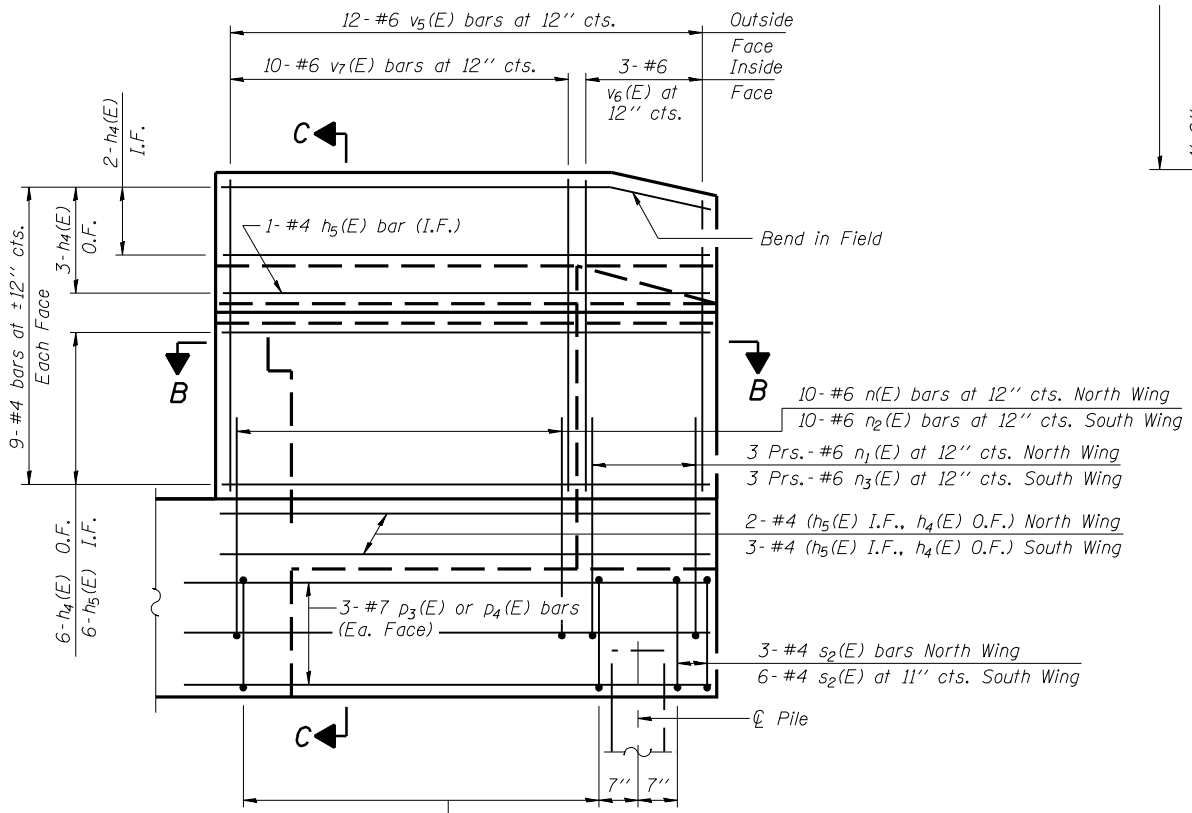

WING WALL ELEVATION
Showing Reinforcement

Notes: Hatched area to be poured after superstructure forms have been removed. Quantity of concrete included with Concrete Superstructure. Space reinforcement in cap to miss anchor bolts. Pour steps monolithically with cap. Reinforcement bars designated (E) shall be epoxy coated. Quantity of concrete in end post included with Concrete Superstructure on sheet 13 of 44. Cost for sleeve shall be included with Concrete Structures.

MIN. BAR LAPS

- #4 Bar - 1'-8"
- #5 Bar - 2'-2"
- #6 Bar - 2'-7"
- #7 Bar - 3'-5"

Corporate License Number 184-001-084
WESTBOUND-WEST ABUTMENT DETAILS
F.A.I. 72 OVER UNION PACIFIC RAILROAD
SECTION (84-9-4)A, HBK, BY, BY-1
SANGAMON COUNTY
STATION 608+51.98
STR NO. 084-0074 EB - 084-0075 WB

MMW 06/27/03
 DAP 07/17/03
 JMM 10/27/03
 sFILE\$ 12/16/2006