

NOTES

Bar splicer assemblies shall be of an approved type and shall develop in tension at least 125 percent of the yield strength of the lapped reinforcement bars.
Splicer rods shall be of minimum 60 ksi yield strength, threaded or coiled full length.
All reinforcement bars shall be lapped and tied to the splicer rods or dowel bars.
Bar splicer assemblies shall be epoxy coated according to the requirements for reinforcement bars.
Other systems of similar design may be submitted to the Engineer for approval. Approval shall be based on certified test results from an approved testing laboratory that the proposed bar splicer assembly satisfies the following requirements:

- ① Minimum Capacity (Tension in kips) = $1.25 \times f_y \times A_t$
- ② Minimum *Pull-out Strength (Tension in kips) = $1.25 \times f_{s_{allow}} \times A_t$

Where f_y = Yield strength of lapped reinforcement bars in ksi.
 $f_{s_{allow}}$ = Allowable tensile stress in lapped reinforcement bars in ksi (Service Load)
 A_t = Tensile stress area of lapped reinforcement bars.
* = 28 day concrete

Bar Size to be Spliced	Splicer Rod or Dowel Bar Length	Strength Requirements	
		Min. Capacity kips - tension	Min. Pull-Out Strength kips - tension
#4	1'-8"	14.7	5.9
#5	2'-0"	23.0	9.2
#6	2'-7"	33.1	13.3
#7	3'-5"	45.1	18.0
#8	4'-6"	58.9	23.6
#9	5'-9"	75.0	30.0
#10	7'-3"	95.0	38.0
#11	9'-0"	117.4	46.8

Bar splicer assemblies shall be according to Section 508 of the Standard Specifications, except as noted. The furnishing and installation of bar splicer assemblies will be measured and paid for at the contract unit price each for "BAR SPLICERS."

The diameter of this part is the same as the diameter of the bar spliced.

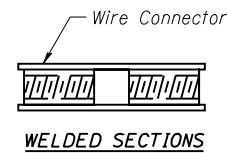
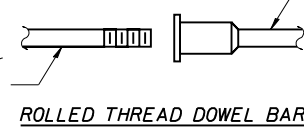

BAR SPLICER ASSEMBLY ALTERNATIVES

** Heavy Hex Nuts conforming to ASTM A 563, Grade C, D or DH may be used.

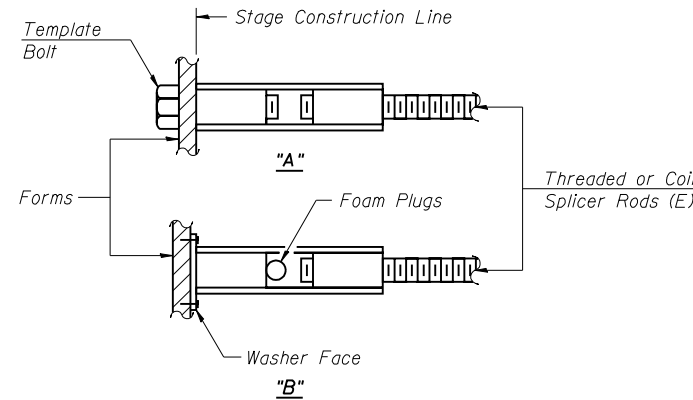

INSTALLATION AND SETTING METHODS

"A" : Set bar splicer assembly by means of a template bolt.
"B" : Set bar splicer assembly by nailing to wood forms or cementing to steel forms.
(E) : Indicates epoxy coating.

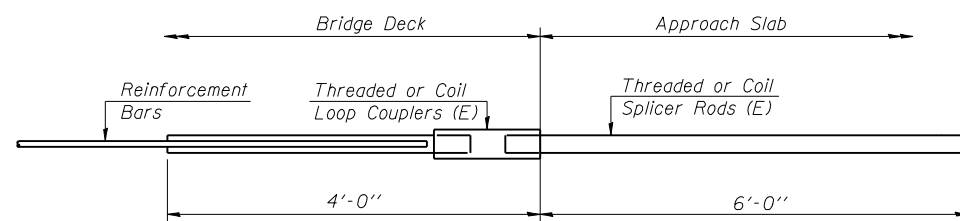

FOR INTEGRAL OR SEMI-INTEGRAL ABUTMENTS

Bar Splicer for #5 bar	
Min. Capacity = 23.0 kips - tension	
Min. Pull-out Strength = 9.2 kips - tension	
No. Required = 0	

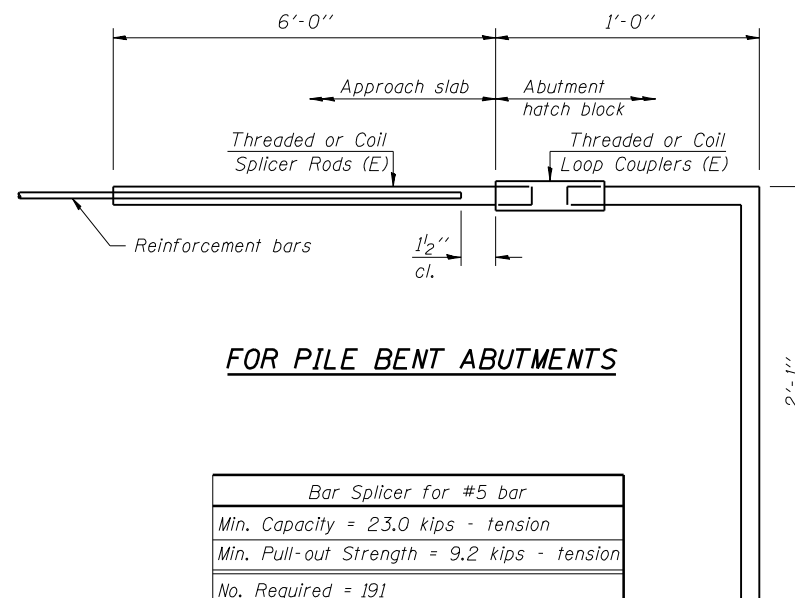

FOR PILE BENT ABUTMENTS

Bar Splicer for #5 bar	
Min. Capacity = 23.0 kips - tension	
Min. Pull-out Strength = 9.2 kips - tension	
No. Required = 191	

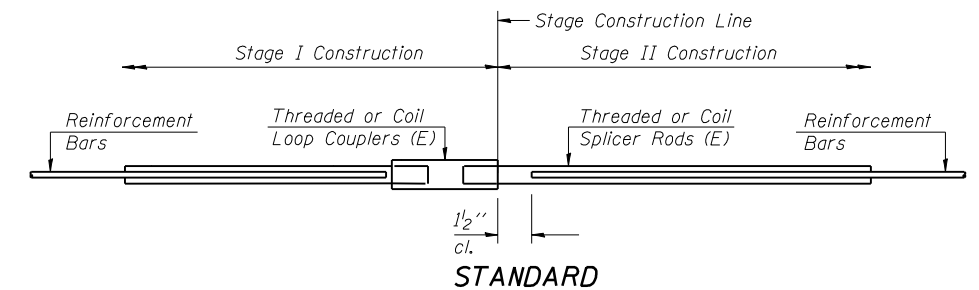

Bar Size	No. Assemblies Required	Location
#5	402	W.B. Top of Slab Stage Construction Line
#5	397	E.B. Top of Slab Stage Construction Line
#5	282	W.B. Bottom of Slab Stage Construction Line
#5	277	E.B. Bottom of Slab Stage Construction Line
#5	40	Abutment Backwalls
#6	16	Abut. Portion Poured With Superstructure

Corporate License Number 184-001-084

BAR SPLICER ASSEMBLY DETAILS
F.A.I. 72 OVER UNION PACIFIC RAILROAD
SECTION (84-9-4)A,HBK,BY,BY-1
SANGAMON COUNTY
STATION 608+51.98
STR NO. 084-0074 EB - 084-0075 WB

© Copyright Hanson Professional Services Inc. SMS_YEARS



JOB#

96S2002B

DATE

01/12/06

LAYOUT
DRAWN
REVIEWED

MMW 06/27/03
DAP 07/17/03
JMM 10/27/03