

SECTION A-A
See sheet 06 of 21 for scupper location relative to parapet.

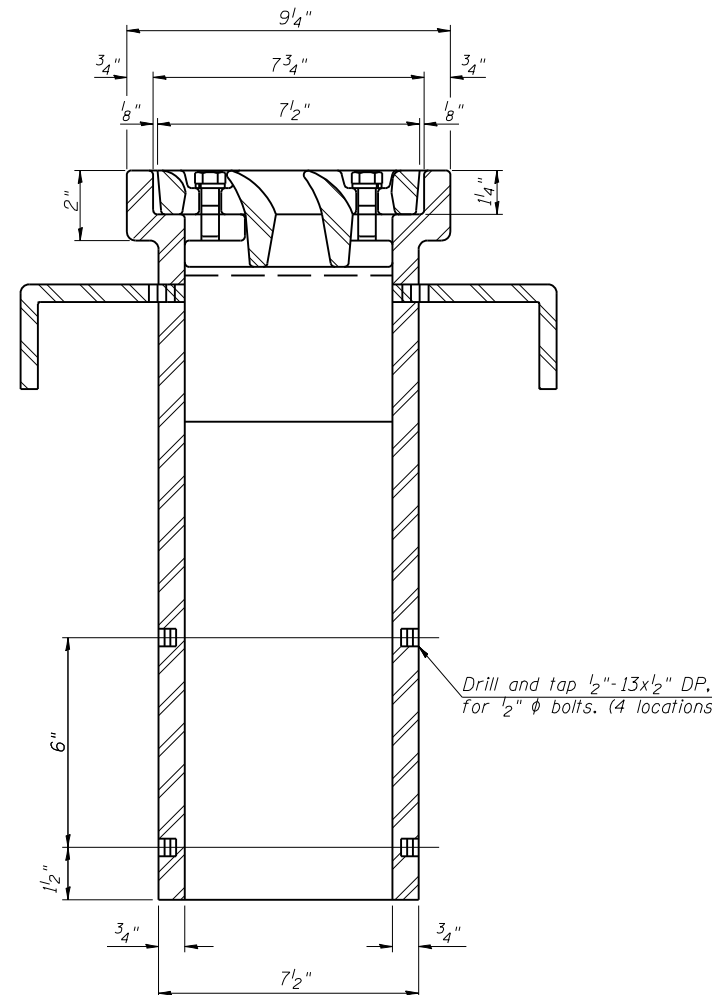

Notes: All cast iron parts shall be gray iron conforming to the requirements of AASHTO M 105, Class 35B.
Bolts, anchor studs, washers and nuts shall conform to the requirements of ASTM A 307 and shall be galvanized according to AASHTO M 232.
The grate, frame and downspout shall be galvanized according to AASHTO M 111 and ASTM A 385. Downspouts located on the exterior side of a painted steel fascia beam shall be painted with the finish coat specified for the exterior side of the fascia beam.
As an alternate, bolts, anchor studs, washers and nuts may be stainless steel according to Article 1006.29(d) of the Standard Specifications.
Structural steel weldments of equal sections and of the same configuration may be substituted for cast iron. Fillet or full penetration welds shall be used for the weldments. Details shall be submitted to the Engineer for approval.
The Contractor shall take appropriate measures to assure that Protective Coat is not applied to the scupper.
Cost of the Grate, Frame, Downspout, Anchor Studs, Bolts, Washers and Nuts including complete installation of the scupper shall be paid for at the contract unit price each for Drainage Scupper, DS-11.

BILL OF MATERIAL

ITEM	UNIT	QUANTITY
Drainage Scupper, DS-11	Each	2

Corporate License Number 184-001-084

DRAINAGE SCUPPER, DS-11
I-72/MACARTHUR BLVD. RAMP C OVER UPRR
SECTION (84-9-4)A,HBK,BY,BY-1
SANGAMON COUNTY
STATION 46+01.97
STRUCTURE NUMBER 084-0516

© Copyright Hanson Professional Services Inc. \$MS_YEAR\$ JOB#



96S2002B

DATE: 11/16/05

LAYOUT: MWM 06/27/03
DRAWN: DAP 01/04/05
REVIEWED: JMM 02/24/05
\$FILES: 12/16/2006