

F.A.P. RTE.	SECTION	COUNTY	TOTAL SHEETS	SHEET NO.
310	115(RS-3,B-2)	MORGAN	42	25
STA.		TO STA.		
FED. ROAD DIST. NO.	ILLINOIS	FED. AID PROJECT		
STATE CONTRACT NO. 72663				

**DETAILS OF MAILBOX TURNOUTS**

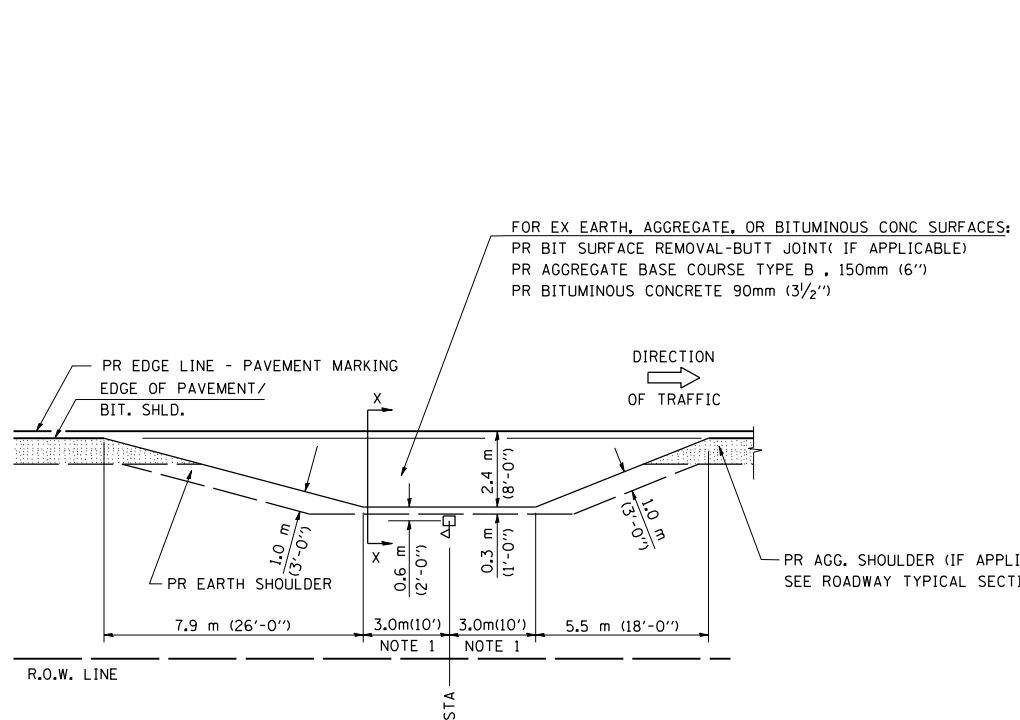

**PLAN - MAILBOX TURNOUTS**

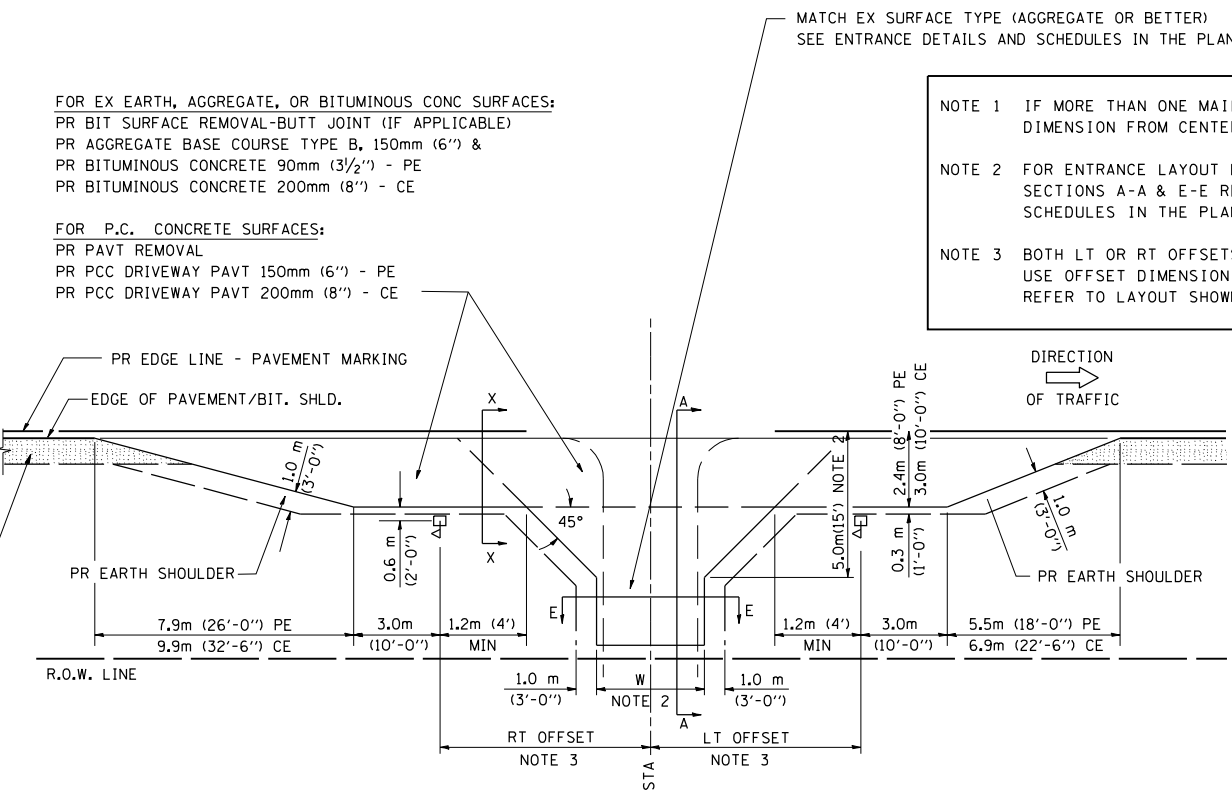

**PLAN - COMBINED MAILBOX TURNOUT WITH TRAILING OR LEADING ENTRANCE**

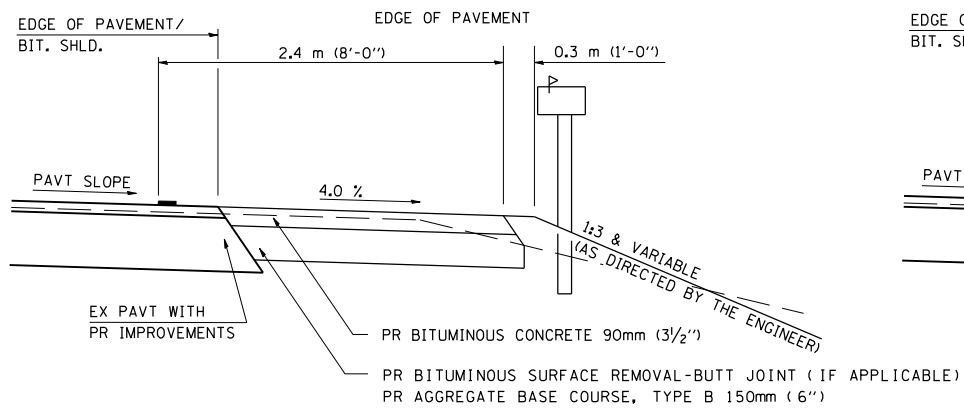

**SECTION X-X THRU MAILBOX TURNOUT  
 ALSO APPLIES TO MAILBOX TURNOUTS COMBINED WITH  
 EX EARTH, AGGREGATE, OR BITUMINOUS PE & FE**

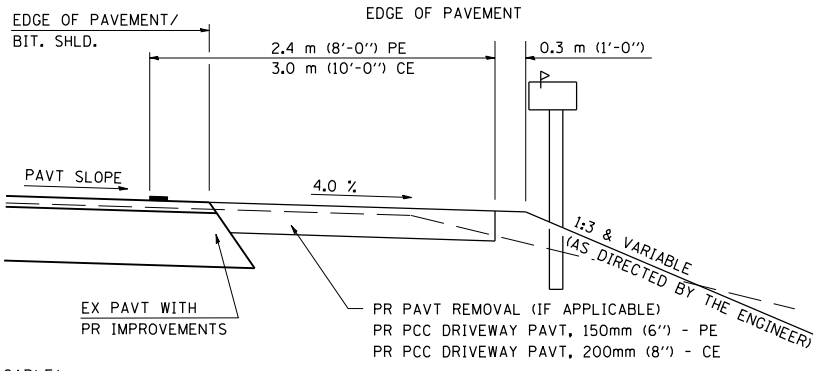

**SECTION X-X THRU MAILBOX TURNOUT  
 COMBINED WITH EX CONC PE OR CE**

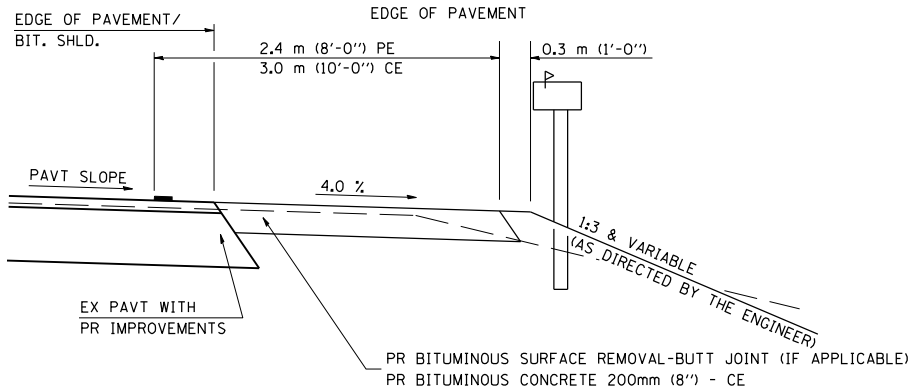

**SECTION X-X THRU MAILBOX TURNOUT  
 COMBINED WITH EX EARTH, AGGREGATE, OR BITUMINOUS CE**

REVISIONS	
NAME	DATE
JCN	2/19/03

**SHEET 2 OF 3**

ILLINOIS DEPARTMENT OF TRANSPORTATION  
**DISTRICT SIX**  
**DETAILS FOR RURAL / URBAN**  
**ENTRANCE & MAILBOX TURNOUT**  
**W / O CONCRETE GUTTER**  
**(3R - PROJECTS)**

SCALE: VERT.  
 HORIZ.  
 DATE: FEBRUARY 23, 1999

DRAWN BY: CADD  
 CHECKED BY: JCN