

F.A.P. RTE.	SECTION	COUNTY	TOTAL SHEETS	SHEET NO.
75		CHRISTIAN	97	92
STA.		TO STA.		
FED. ROAD DIST. NO.	ILLINOIS	FED. AID PROJECT		

D 6 RESURFACING 2007

LENGTH OF SLACK FOR LOOP LEAD-INS SHALL PROVIDE FOR MAKING THE SPLICE ON TOP OF THE HANDHOLE AND ONE COMPLETE LOOP OF THE INTERIOR OF THE HANDHOLE. THE SPLICE SHALL BE SUPPORTED BY A CABLE HOOK.

THE LOOP LEAD-IN CONDUIT HOLES SHALL BE PLACED AS CLOSE TO THE CURB AS POSSIBLE TO PERMIT SAW OVERLAP WITHOUT SCARRING FACE OF CURB. IN NON-CURB LOCATIONS THE DISTANCE SHALL NOT BE LESS THAN 6".

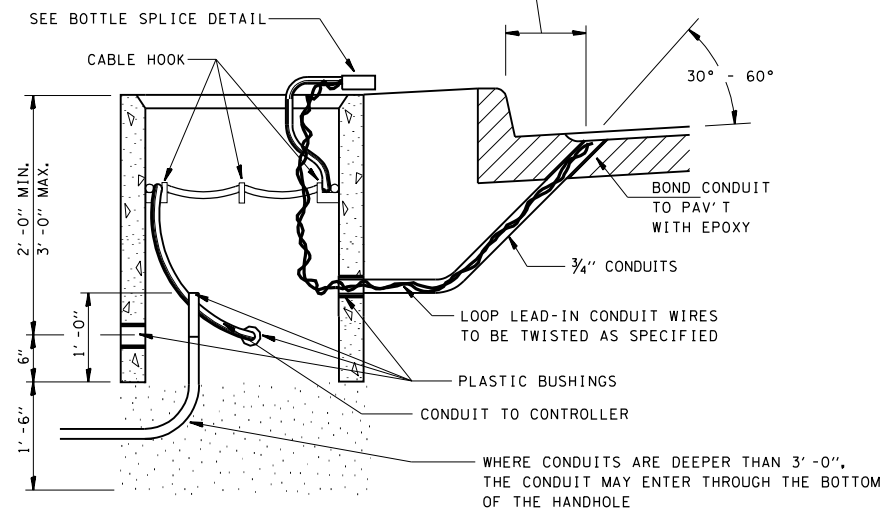

HANDHOLE CABLE CONNECTIONS

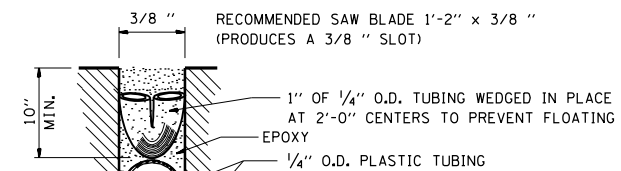
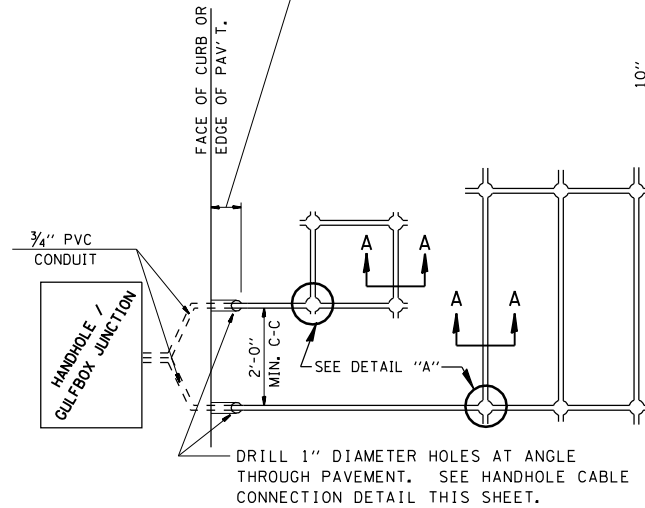

SECTION A-A

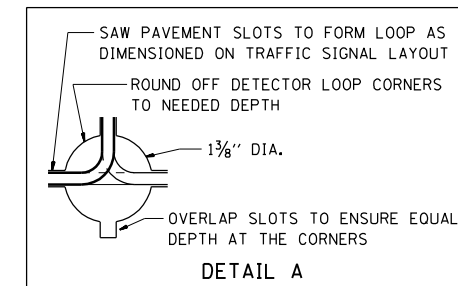

DETAIL A

PAVEMENT SAWING DETAIL FOR TUBE ENCASED DETECTOR LOOP WIRE

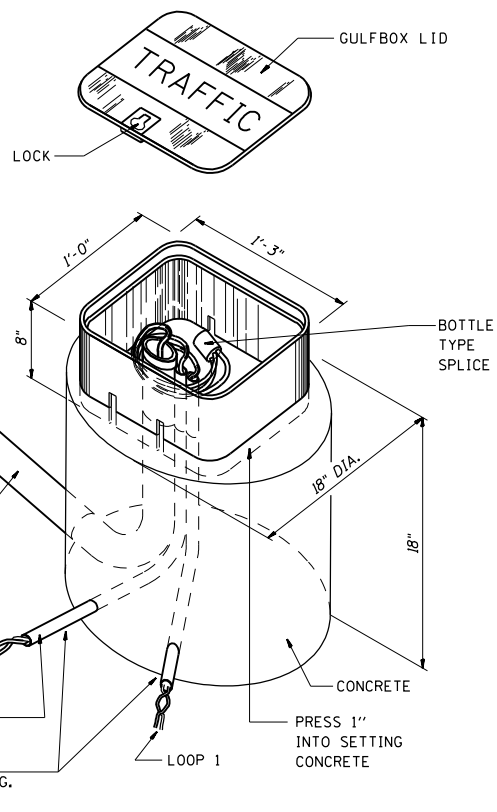

GULFBOX JUNCTION DETAIL

(SHOWING CONNECTION OF TUBE-ENCASED DETECTOR LOOP TO MULTI-PAIR LEAD-IN CABLE)

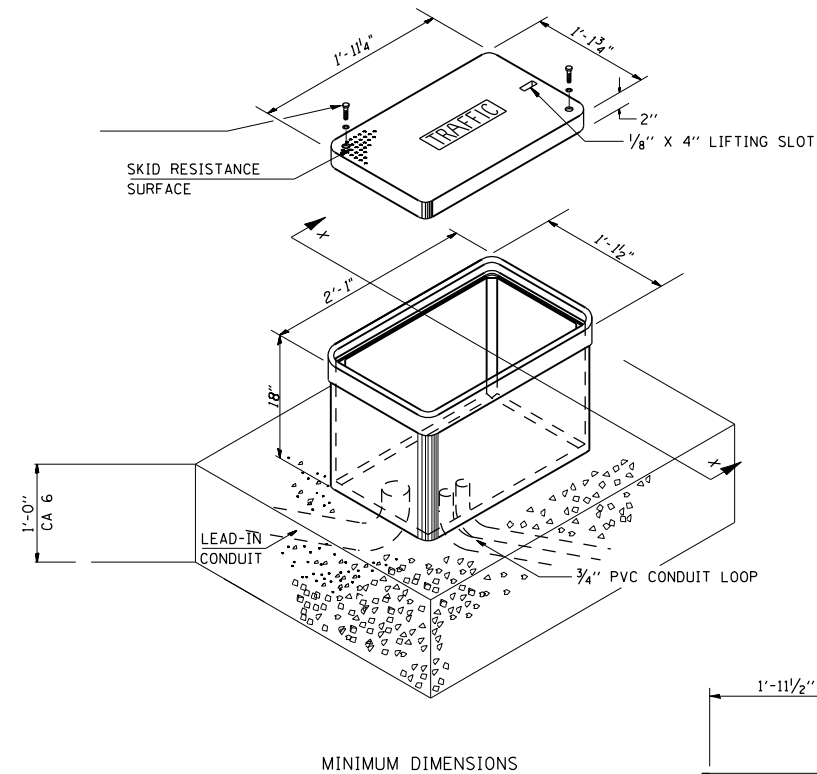

JUNCTION BOX (SPECIAL)

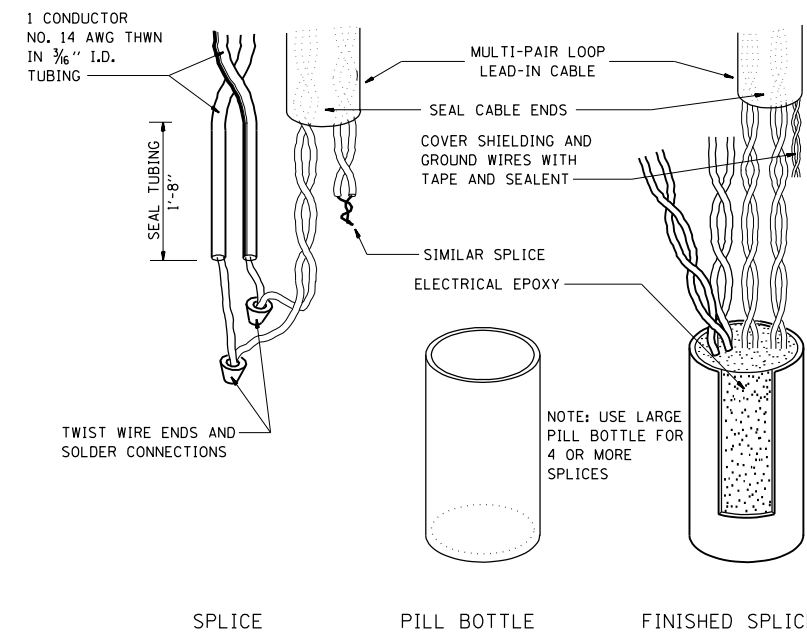
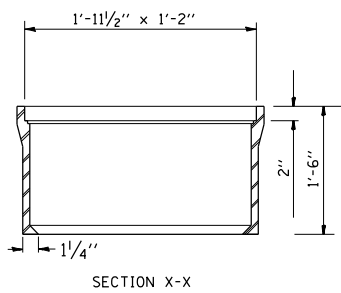

SPLICE

PILL BOTTLE

FINISHED SPLICE

BOTTLE SPLICE DETAIL

REVISIONS	
NAME	DATE

ILLINOIS DEPARTMENT OF TRANSPORTATION
 TRAFFIC SIGNAL DETECTOR LOOP DETAILS
 FAP 75 (IL 29)
 D 6 RESURFACING 2007
 CHRISTIAN COUNTY

SCALE: VERT. HORIZ.
 DATE

DRAWN BY
 CHECKED BY