

NOTE:

1. THRUST BLOCKS TO BE USED AT 1/16(22-1/2°) OR GREATER BENDS & AT ALL ENDS TO BE PLUGGED.
2. PRECAST CONCRETE THRUST BLOCKS TO BE PLACED AGAINST FIRM, UNDISTURBED SOIL.

THRUST BLOCK DETAIL

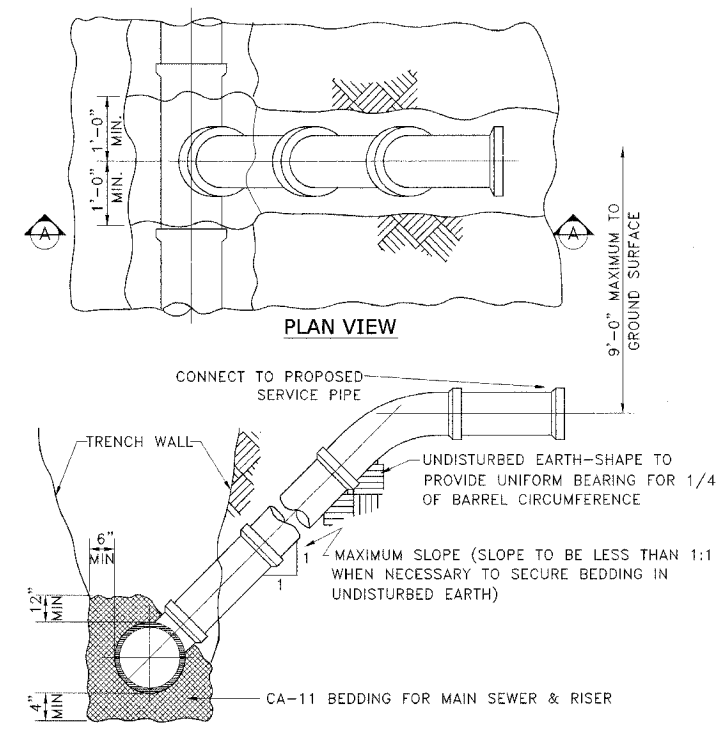

TYPICAL RISER FOR SERVICE LATERAL

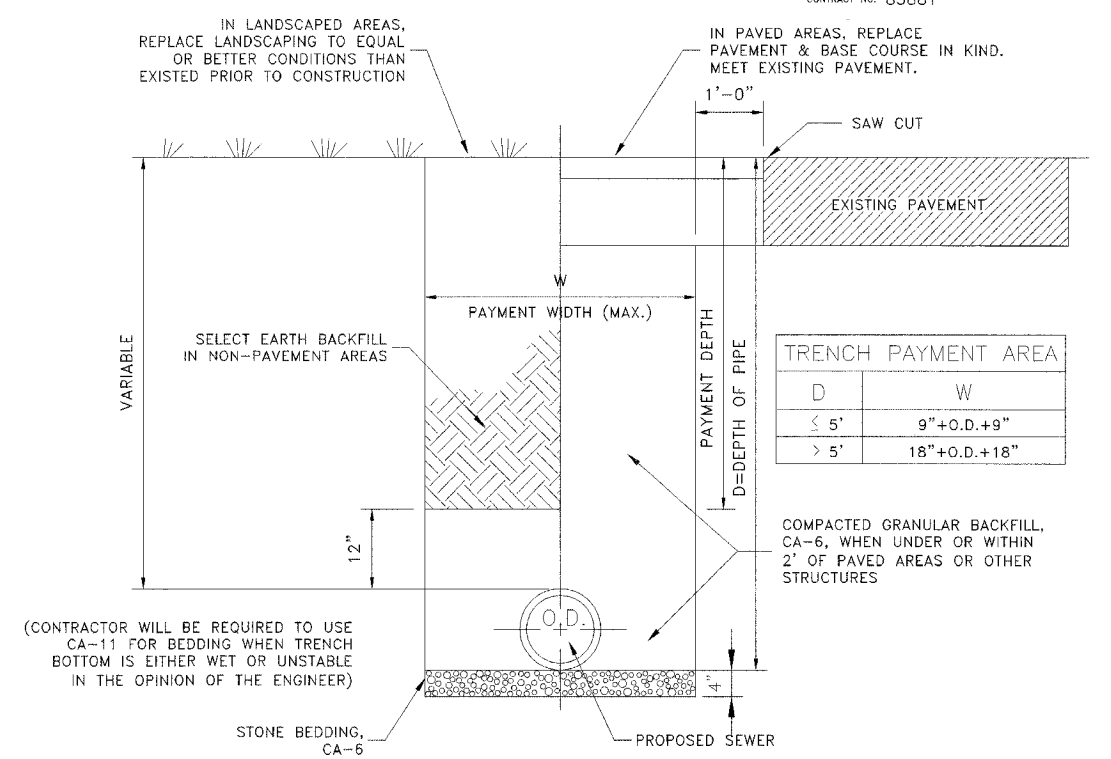

TYPICAL WATER MAIN TRENCH DETAIL

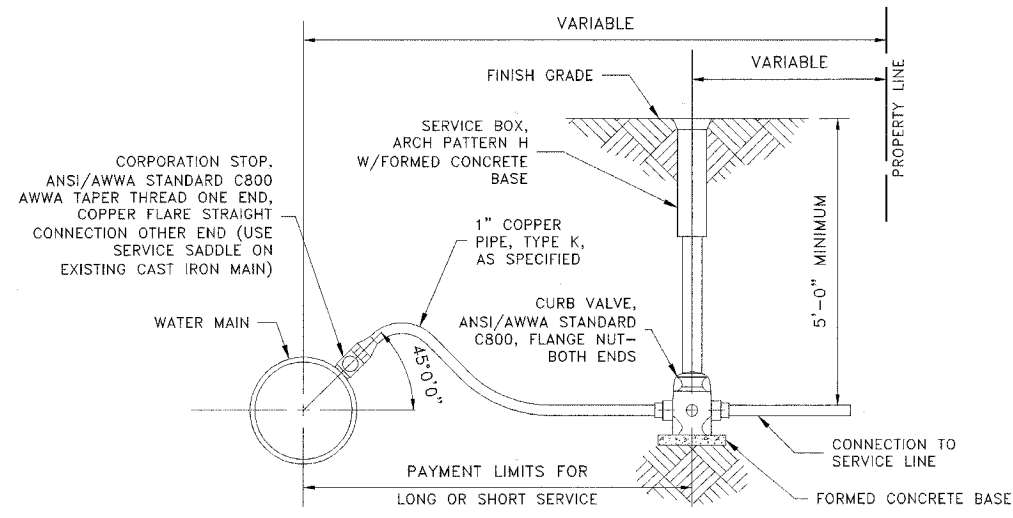

TYPICAL WATER SERVICE DETAIL

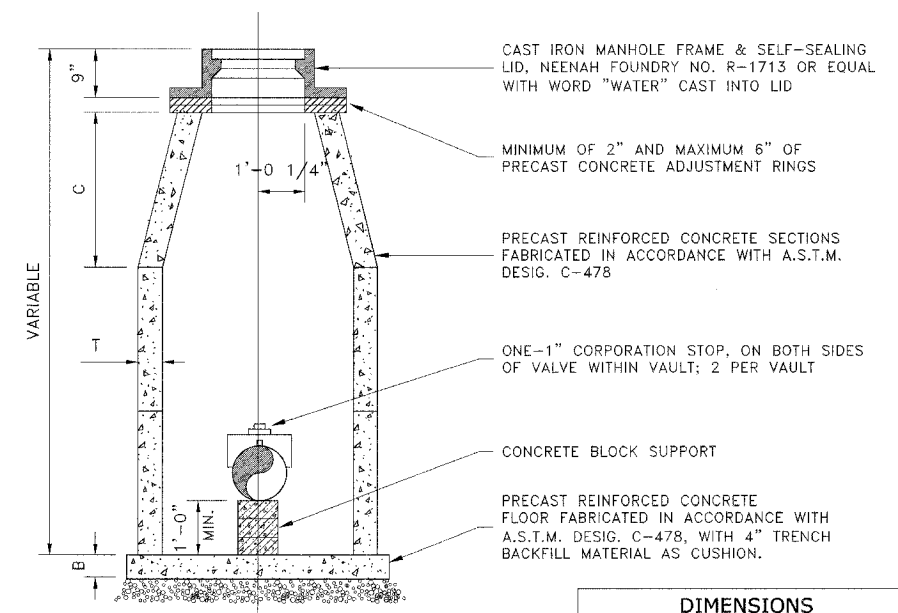

DIMENSIONS			
D	C	T(MIN.)	B
4'-0"	2'-6"	4"	6"
5'-0"	3'-9"	5"	8"

STANDARD VALVE VAULT DETAIL

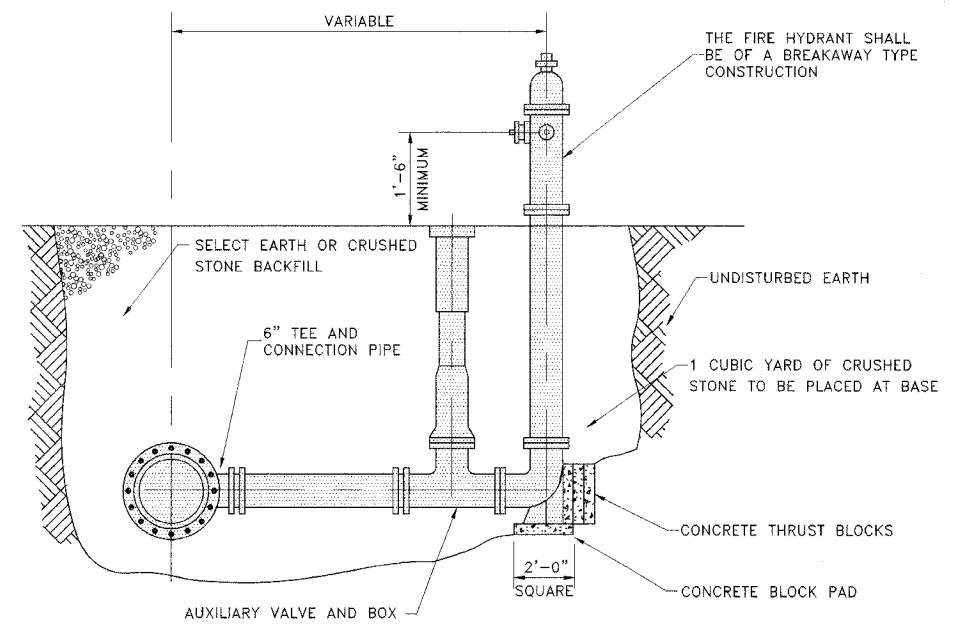

FIRE HYDRANT DETAIL

Drawing File: W:\Projects\12504263 - Profile Ave 2nd Phase\2nd Project\Drawings-Detail.dwg Oct 05, 2006 - 2:32pm