

ROUTE NO.	SECTION	COUNTY	SHEET	DATE	SHEET NO.
FAP 0525		WINNEBAGO	157	135	28
FED. ROAD DIST. NO. 7					50 SHEETS
ILL. ROAD DIST. NO. 7					
FED. AID PROJECT					
02-00518-00-BR					

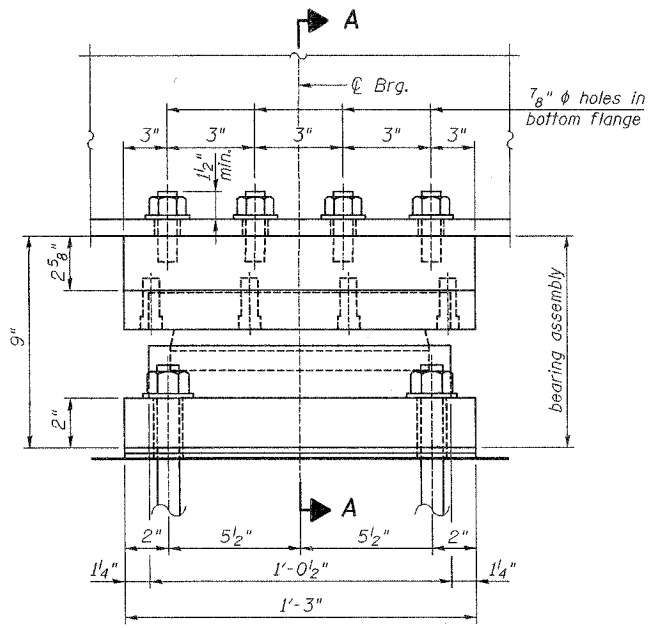

ELEVATION AT PIER 4

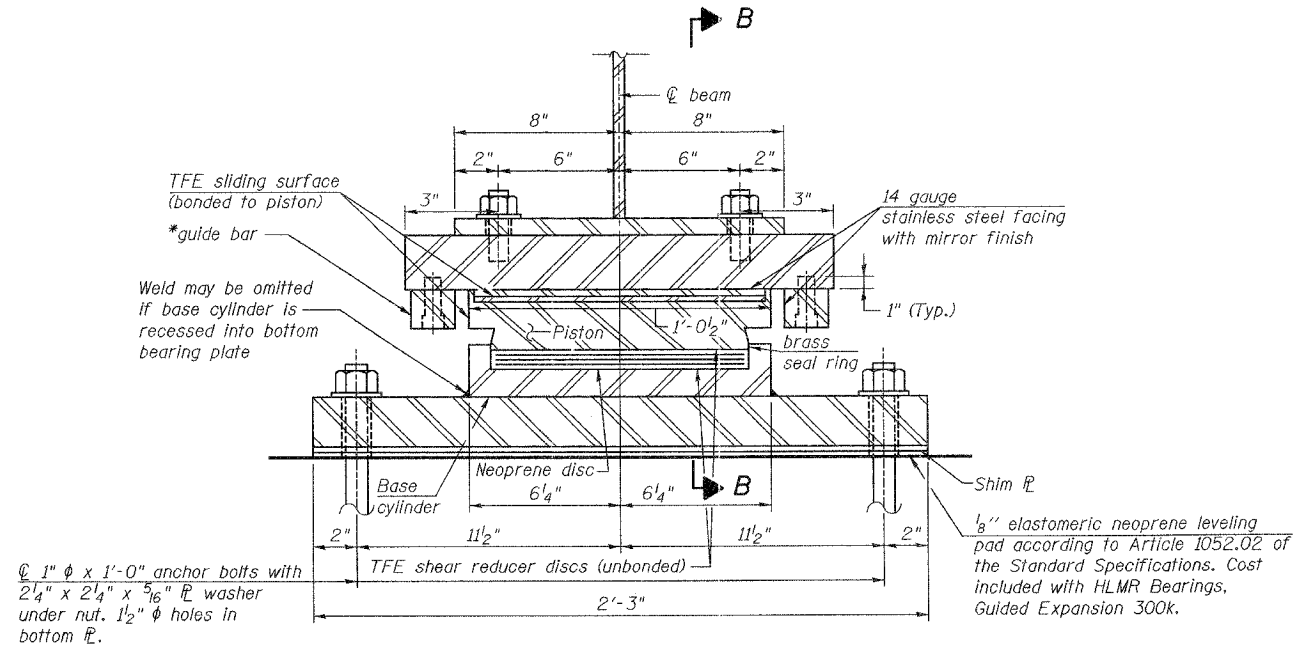

SECTION A-A

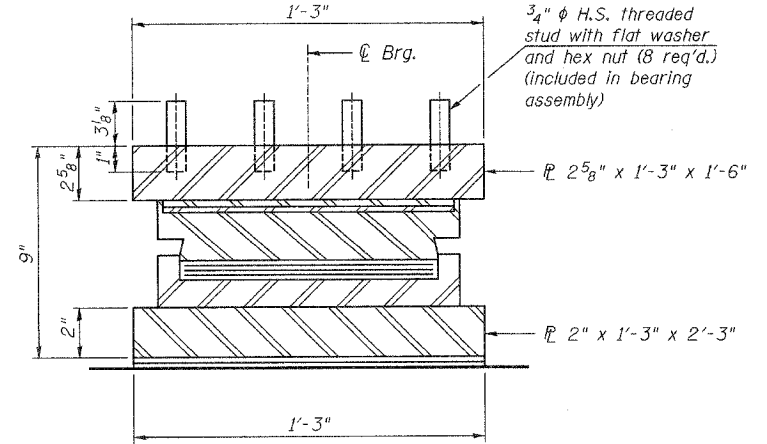

SECTION B-B
(Guide Bar omitted for clarity)

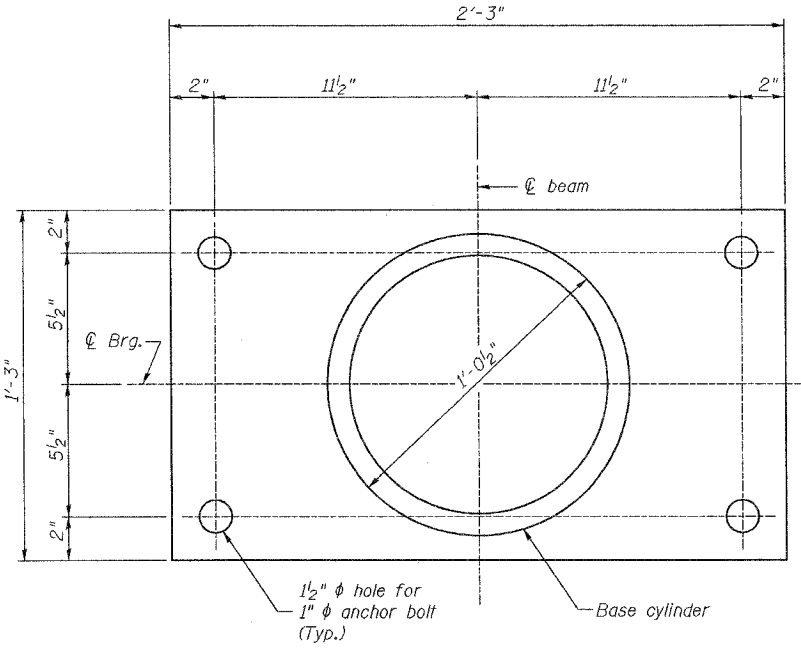

BOTTOM BEARING PLATE AND BASE CYLINDER PLAN

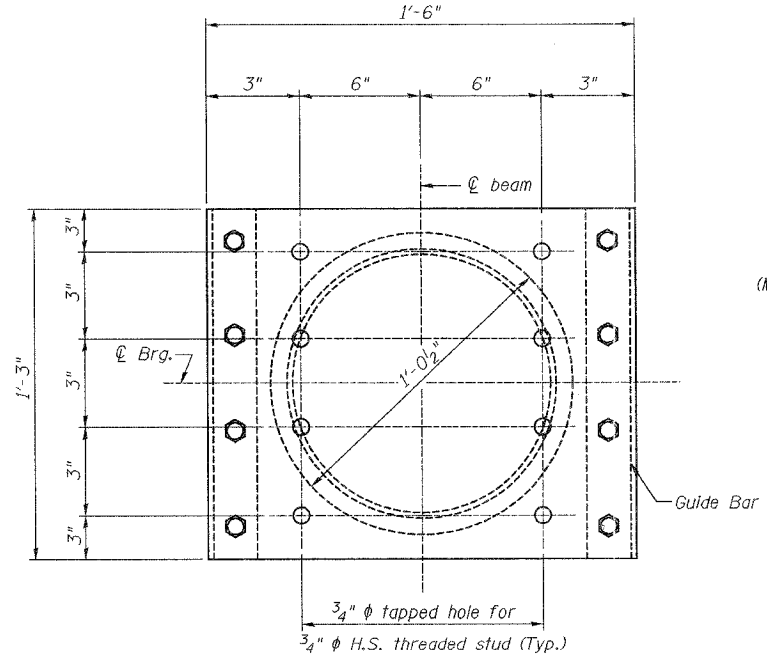

TOP BEARING PLATE AND PISTON PLAN

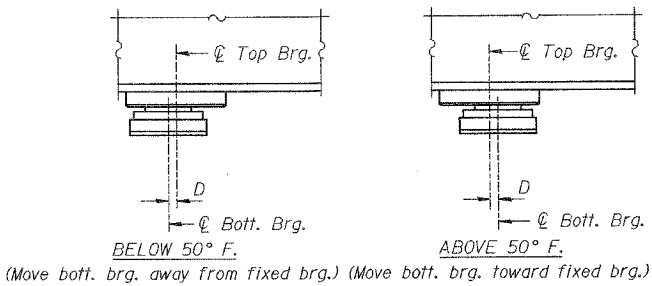

SETTING ANCHOR BOLTS AT EXP. BRG.
D = 1/8" per each 100' of expansion for every 15° temp. change from the normal temp. of 50° F.

* As alternates to the bolted connection shown, the guide bars may be connected to the top bearing plate by groove welds or the guide bars and top bearing plate may be fabricated as a single piece.

Bearing Data	
Vertical Design Load	251 K
Total Required Movement	1 3/8"

BILL OF MATERIAL

Item	Unit	Total
HLMR Bearings, Guided Expansion 300k	Each	5

NOTES

The plates of the Bearing Assembly shall be AASHTO M270, Grade 50. For Anchor Bolt Installation details see Sheet 29 of 50. The Bearing Assembly shall be capable of transmitting 20% of the vertical design load as a horizontal force in the direction normal to the guide bars. Shim plate(s) shall be the full dimension of the bottom bearing plate. Cost of shims is included with HLMR Bearings, Guided Expansion 300k. Anchor Bolts shall be high strength bolts (AASHTO M164, Type 1 or 2).

GUIDED EXPANSION POT BEARING AT PIER 4

Corporate License Number 184-001-084

BEARING DETAILS

WESTBOUND HARRISON AVENUE
OVER UP & CC&P RAILROAD
F.A.P. ROUTE 0525
SECTION 02-00518-00-BR
ROCKFORD, ILLINOIS
STATION 95+25.35
STRUCTURE NO. 101-6109

© Copyright Hanson Professional Services Inc. 2006



JOB NO.
03R1751
DATE
12/14/06

14856 PM 12/14/06
 12/13/2006 04:48 PM
 1403 jobs03R1751/Struct/Sheet/West Bound/02-00518-00-BR/Bar/Bar.Dwg
 LAYOUT JKR 12/14/06
 DRAWN MMJ/JKR 07/13/06
 REVIEWED FLN 08/02/06