

F.A.I. RTE.	SECTION	COUNTY	TOTAL SHEETS	SHEET NO.
*	**	WILLIAMSON	917	289
STA.		TO STA.		
FED. ROAD DIST. NO.		ILLINOIS FED. AID PROJECT		
* I-57, & OLD IL 13 (FAU 9629)				
** (X1-6-2)VB-2, (X1-6)HBK-2				

## TYPICAL SECTION - STAGE 4

### STAGE 4 NOTES

INSTALL TEMPORARY CONCRETE BARRIER AND APPLY PAVEMENT MARKINGS USING NIGHT-TIME WORK. APPLY TRAFFIC CONTROL STANDARDS 701400, 701401, AND 701411.

#### NORTHBOUND I-57

1. SHIFT TWO LANES OF TRAFFIC TO MEDIAN SHOULDER.
2. MAKE SAW CUTS NEEDED FOR PAVEMENT REMOVAL OR RUBBLIZATION AT NIGHT WITH LANE CLOSURE.
3. INSTALL TEMPORARY CONCRETE BARRIER.
4. CLOSE OLD IL 13 ENTRANCE RAMP "E" (APPROXIMATELY 14 MONTHS).
5. OLD IL 13 EXIT RAMP "EE" REMAINS OPEN.
6. COMPLETE ALL PROPOSED PAVEMENT WORK BEHIND THE TEMPORARY CONCRETE BARRIER.
7. COMPLETE STAGE 1 BRIDGE REMOVAL AND STAGE 1 BRIDGE CONSTRUCTION.

#### SOUTHBOUND I-57

1. SHIFT TWO LANES OF TRAFFIC TO MEDIAN SHOULDER.
2. MAKE SAW CUTS NEEDED FOR PAVEMENT REMOVAL OR RUBBLIZATION AT NIGHT WITH LANE CLOSURE.
3. INSTALL TEMPORARY CONCRETE BARRIER.
4. CLOSE OLD IL 13 ENTRANCE RAMP "FF" (APPROXIMATELY 14 MONTHS).
5. OPEN OLD IL 13 TEMPORARY ENTRANCE RAMP "FF".
6. OLD IL 13 EXIT RAMP "F" REMAINS OPEN.
7. COMPLETE ALL PROPOSED PAVEMENT WORK BEHIND THE TEMPORARY CONCRETE BARRIER.
8. COMPLETE STAGE 1 BRIDGE REMOVAL AND STAGE 1 BRIDGE CONSTRUCTION.

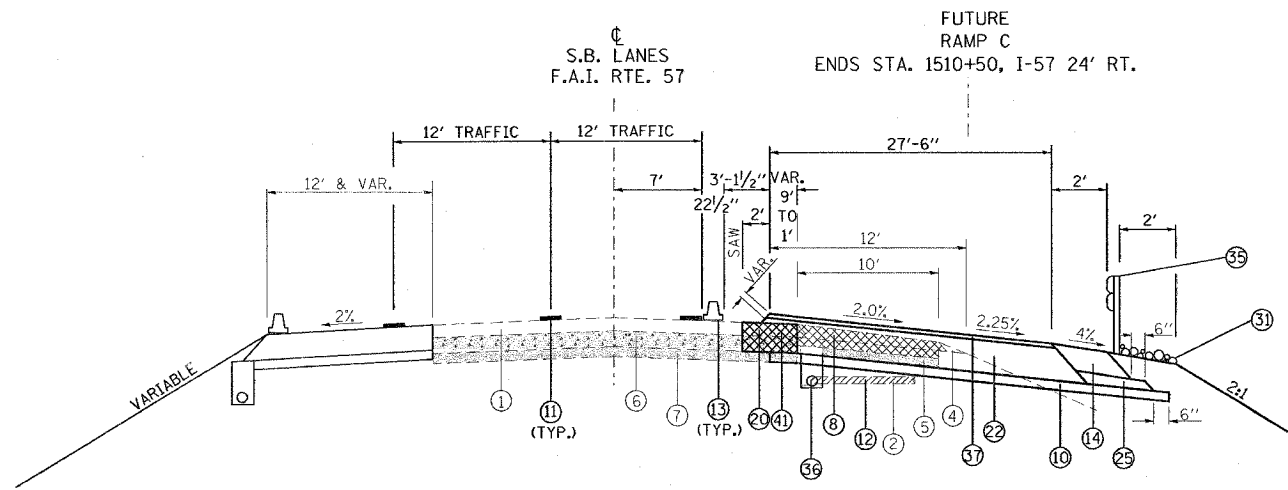

**TO BE USED:**  
STA. 1510+00 TO STA. 1511+11 SB I-57

**NOTE:**  
TRANSITION PROFILE GRADE FROM EXISTING AT STA. 1510+00 TO PROPOSED AT STA. 1510+30 RT. C SBL

- |   |  |
|---|--|
| <ul style="list-style-type: none"> <li>① EXISTING BITUMINOUS RESURFACING (VARIES 4 1/2" TO 5 1/4")</li> <li>② EXISTING PIPE UNDERDRAINS 4"</li> <li>③ EXISTING BITUMINOUS SHOULDERS</li> <li>④ EXISTING AGGREGATE SHOULDERS TYPE B (WEDGE)</li> <li>⑤ EXISTING AGGREGATE BASE</li> <li>⑥ EXISTING 10" P.C.C. PAVEMENT, 1 1/2" PARABOLIC CROWN</li> <li>⑦ EXISTING 6" AGGREGATE SUB-BASE (4" ON RAMP "C")</li> <li>⑧ PAVED SHOULDER REMOVAL</li> <li>⑨ BITUMINOUS CONCRETE BINDER COURSE, SUPERPAVE, IL-19.0, N90 9 3/4"</li> <li>⑩ SUB-BASE GRANULAR MATERIAL 6"</li> <li>⑪ TEMPORARY PAINT PAVEMENT MARKING</li> <li>⑫ PIPE UNDERDRAIN REMOVAL</li> <li>⑬ TEMPORARY CONCRETE BARRIER</li> <li>⑭ BITUMINOUS SHOULDERS SUPERPAVE 8"</li> <li>⑮ BITUMINOUS CONCRETE BINDER COURSE, SUPERPAVE, IL-19.0, N90 12"</li> <li>⑯ POLYMERIZED BITUMINOUS CONCRETE BINDER COURSE, SUPERPAVE, IL-19.0, N105 5"</li> <li>⑰ BITUMINOUS SURFACE REMOVAL 5"</li> <li>⑱ RUBBLIZING PORTLAND CEMENT CONCRETE PAVEMENT</li> <li>⑲ AGGREGATE SHOULDERS TYPE A 8"</li> <li>⑳ PAVEMENT REMOVAL</li> <li>㉑ PROCESSING LIME MODIFIED SOILS 12"</li> <li>㉒ BITUMINOUS CONCRETE BINDER COURSE, SUPERPAVE, IL-19.0, N90 11"</li> </ul> | <ul style="list-style-type: none"> <li>㉓ BITUMINOUS CONCRETE BINDER COURSE, SUPERPAVE, IL-19.0, N90 7 3/4"</li> <li>㉔ CONCRETE GUTTER, TYPE B</li> <li>㉕ SUB-BASE GRANULAR MATERIAL, TYPE C</li> <li>㉖ POLYMERIZED BITUMINOUS CONCRETE BINDER COURSE, SUPERPAVE, IL-19.0, N105 (VAR)</li> <li>㉗ POLYMERIZED BITUMINOUS CONCRETE SURFACE COURSE, SUPERPAVE, MIX E, N105 1 1/2"</li> <li>㉘ CONCRETE BARRIER, DOUBLE FACE, 42 INCH HEIGHT</li> <li>㉙ TEMPORARY SHEET PILING</li> <li>㉚ BITUMINOUS SHOULDER SUPERPAVE 6 1/2"</li> <li>㉛ STONE RIPRAP, CLASS A3</li> <li>㉜ STEEL PLATE BEAM GUARDRAIL, TYPE A</li> <li>㉝ AGGREGATE SHOULDERS, TYPE B (WEDGE)</li> <li>㉞ BITUMINOUS CONCRETE BINDER COURSE, SUPERPAVE, IL-19.0, N90 12 3/4"</li> <li>㉟ TEMPORARY STEEL PLATE BEAM GUARDRAIL, TYPE A</li> <li>㊱ PIPE UNDERDRAIN 4"</li> <li>㊲ POLYMERIZED BITUMINOUS CONCRETE BINDER COURSE, SUPERPAVE, IL-19.0, N105 2 1/4"</li> <li>㊳ STABILIZED SUB-BASE (VARIABLE DEPTH)</li> <li>㊴ STRIP REFLECTIVE CRACK CONTROL</li> <li>㊵ BITUMINOUS CONCRETE BINDER COURSE, SUPERPAVE, IL-19.0, N90 5"</li> <li>㊶ BITUMINOUS CONCRETE BINDER COURSE, SUPERPAVE, IL-19.0, N90 15"</li> <li>㊷ BITUMINOUS CONCRETE BINDER COURSE, SUPERPAVE, IL-19.0, N90 (VAR)</li> <li>㊸ SUB-BASE GRANULAR MATERIAL 10"</li> <li>㊹ POLYMERIZED BITUMINOUS CONCRETE SURFACE COURSE, SUPERPAVE, MIX E, N105 (VAR.)</li> <li>㊺ BITUMINOUS CONCRETE SURFACE COURSE, SUPERPAVE, MIX C, N70 1 1/2"</li> </ul> |
|---|--|

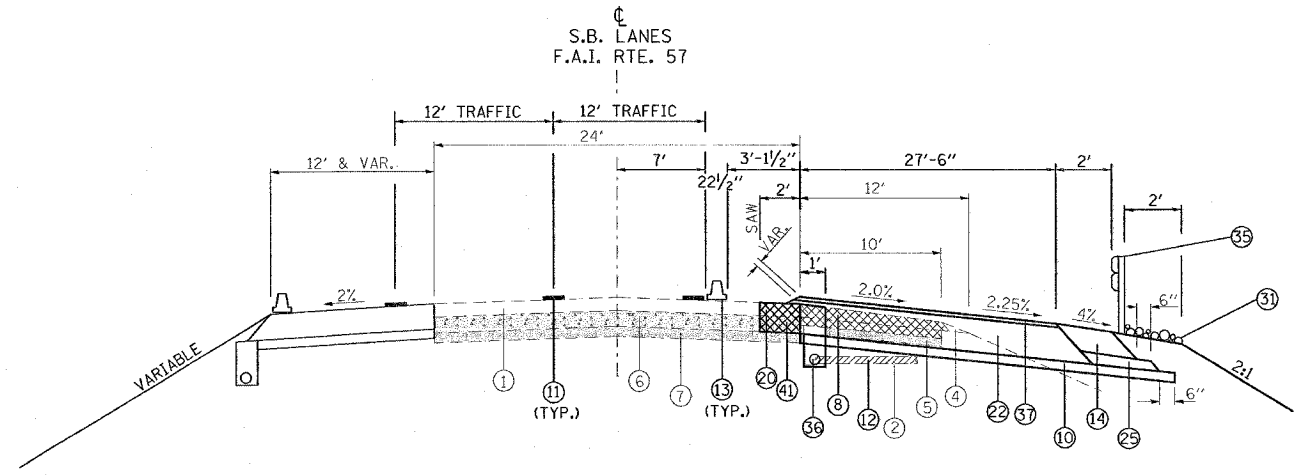

**TO BE USED:**  
STA. 1511+11 TO STA. 1511+80 SB I-57

- NOTE:**
1. DEPTH OF EXISTING BITUMINOUS SHOULDERS
    - NBL: MEDIAN SHOULDER 9 3/4"
    - OUTSIDE SHOULDER 10"
    - SBL: MEDIAN SHOULDER 9"
    - OUTSIDE SHOULDER 9 1/2"

REVISIONS	
NAME	DATE

ILLINOIS DEPARTMENT OF TRANSPORTATION

**FAI-57  
STAGE 4  
TYPICAL AND NOTES  
SHEET 1 OF 17**

SCALE: VERT. NONE  
          HORIZ. DATE  
DRAWN BY CNH  
CHECKED BY

PLOT DATE = 12/14/2006  
 PLOT SCALE = 50.0000 / IN.  
 USER NAME = harsco